



THE
SPORTSMAN'S
LIBRARY

The Sportsman's Library

VOL. X

GLIDING AND SOARING

By C. H. LATIMER-NEEDHAM

*A List of Volumes in "The Sportsman's Library"
will be found at the end of this book.*

THE SPORTSMAN'S LIBRARY

GLIDING AND SOARING

By

C. H. LATIMER-NEEDHAM

M.Sc. (Eng.), F.R.A.E.S.

Vice-President, British Gliding Association

Hon. Instructor, London Gliding Club, 1930-1933

First British Holder of "C" soaring pilot's Certificate

LONDON

PHILIP ALLAN

69 GREAT RUSSELL STREET

First Published in 1935.

MADE AND PRINTED IN GREAT BRITAIN BY
STEPHEN AUSTIN & SONS, LTD., AT HERTFORD,
AND PUBLISHED BY PHILIP ALLAN & CO., LTD.,
AT 69 GREAT RUSSELL STREET, LONDON, W.C. 1.

CONTENTS

CHAPTER	PAGE
I. THE HISTORY OF SOARING FLIGHT	9
II. ELEMENTARY AERODYNAMICS	23
III. THE CONTROL SYSTEM	40
IV. ERECTION AND RIGGING	52
V. GLIDING—ELEMENTARY TRAINING	65
VI. GLIDING—ADVANCED TRAINING	85
VII. SOARING	103
VIII. SAILING	122
IX. EXTENDED SAILING FLIGHTS	143
X. AUTO-TOWING AND AERO-TOWING	157
XI. MATERIALS OF CONSTRUCTION	180
XII. THE CONSTRUCTION OF GLIDERS AND SAILPLANES	190
XIII. MAINTENANCE AND REPAIRS	213
XIV. THE SOARING SITE	228
APPENDIX I. B.G.A. Inspector's Report on Construction of Glider for Certifi- cate of Airworthiness	237
APPENDIX II. B.G.A. Manufacturing Requirements for Gliders and Sail- planes	241
APPENDIX III. B.G.A. Regulations Governing Auto-Towing	244
APPENDIX IV. B.G.A. Regulations Governing Aeroplane-Towing	246
APPENDIX V. B.G.A. Regulations Governing Power Launching	248
APPENDIX VI. B.G.A. Provisional Regu- lations Governing Winch Launching	251
INDEX	253

ILLUSTRATIONS

	PAGE
THREE SAILPLANES IN FLIGHT AT SUTTON BANK, YORKSHIRE	8
THE 'FALCON' INTERMEDIATE SOARING GLIDER .	52
THE 'GRUNAN BABY II'	104
LAUNCHING THE 'TERN' SAILPLANE . . .	130
THE 'RHÖNADLER' IN SAILING FLIGHT . . .	142
THE FIRST BRITISH SAILPLANE 'ALBATROSS' (1930) EQUIPPED FOR TOWED FLIGHT. . .	160
THE 'SCUD II'	178
THE 'GRUNAN BABY' IN SOARING FLIGHT . .	230



THREE SAILPLANES IN FLIGHT AT SUTTON BANK,
YORKSHIRE.

CHAPTER I

THE HISTORY OF SOARING FLIGHT

The complete history of motorless flight can never be written, since the earliest attempts and struggles must be lost in antiquity. Thousands of years ago, no doubt, man watched with envy and interest the graceful movement of birds through the unlimited aerial spaces, and some at least must have sought to emulate them, and so share their wonderful secret. More puzzling still has been the effortless flight of the large tropical birds, so simple must it have appeared.

Nature, however, did not give up her secrets without a keen struggle, which probably cost many lives of the most foreseeing and venturesome, and only slowly has the knowledge been wrested, bit by bit, until at last human soaring flight has become a wonderful and definite achievement.

The earliest experimenters in all probability

were not sure themselves what they sought. Some probably saw in gliding a sound milestone and a natural stepping stone to greater things ; others hoped to soar to great heights without effort on their part, whilst others again were still more ambitious in their endeavour to conquer the principles of both sustentation and manual propulsion together. For this reason it is not easy in many cases for the chronicler to sift the little information available and to extract only those attempts at pure gliding or soaring flight ; and, moreover, all attempts at flight that met with any success at all must have contributed in some measure to the common goal, human flight.

Relics have been found in India which suggest that bird flight was imitated long ago, but there is apparently no record to show with what success. Man-lifting kites are said to have been used in China over two thousand years ago, and, as this is in reality aerial flight through and against the wind, this constituted the earliest human flight. A kite, after all, closely resembles a glider, and, in fact, gliders have been flown as kites, so that this may

be said to be the real beginning of practical gliding. The main difference between a kite and a glider is that the pull on the retaining cord in the former substitutes the weight in the latter, so that if the significance of this had been fully realized at the time, and the kite used as a basis for gliding experiments, it is probable that the advent of flying, at least in motorless aircraft, might have been at a much earlier period, and thus have altered the whole sequence and history of flight.

The opening pages of practical flying, apart from the above, are credited to Leonardo da Vinci, an Italian who, in the fifteenth and early part of the sixteenth centuries, made a long study of bird flight, and then prepared plans and notes for the construction of a man-carrying machine. Da Vinci's manuscript on bird flight, together with sketches and diagrams, undoubtedly served as a basis of design for several years. It is said that he actually constructed and flew one machine, but unfortunately no proof of this is available.

That da Vinci had a good understanding of aerial propulsion is shown by the following

extract from his notes "On the Flight of Birds" :—

"Beyond just sustaining itself by its wings it must at will double and triple the movement in order to escape pursuit or to follow its prey, whence in such an effort it is necessary for it to double and triple its force, and beyond that, carry as much weight in its claws, in the air, as equals its own weight : as one sees the falcon carry the duck, and the eagle the hare, by which thing is it very well demonstrated where such super-abundant force is distributed, but *it needs little force to sustain itself and to balance them on the currents of the wind* and to direct the shaft in its paths : a little movement of the wings is sufficient and as much more slow movement as the bird is larger."

Bernier and the Marquis de Bacquerille, both of France, built flapping and gliding machines in the years 1678 and 1742 respectively, with which very short flights were carried out.

In England, Sir George Cayley, known as the 'Father of flying', made an extensive study of aviation together with many experiments.

To this Englishman, who lived many years ahead of his time, must go the honour of the first known glider flight in a machine of his own design which incorporated controls not altogether unlike those in use to-day. Several short flights were made about the year 1808, but his desire to achieve engined flight prevented the attainment of full success.

Thirty years later Captain le Bris, a French sailor, constructed a glider, 'The Albatross,' of 215 sq ft wing area and weighing 92 lbs, with which he achieved a glide of 600 ft after taking off from a 150 ft high hill. Towed glides at a height of 300 ft were also accomplished.

The achievements of a South African pioneer, Goodman Household, have only recently come to light. After a ten-year study of birds and their flight, Household commenced building gliding machines by basing his calculations on the weights and spans of birds he had shot. His last glider was probably more like the true sailplane of to-day than any other machine built during the following sixty years, and was characterized by its huge

wing span. With this he made successful flights, but was finally induced to relinquish his efforts.

Another French experimenter was Pierre Moillard who produced a rather crude glider in 1881, in which the wing position was adjustable by foot control, but little came of this.

The real 'Father of gliding' was Otto Lilienthal, an engineer of Berlin, who, together with his brother Gustave, collected all the available data, and in 1890, after a life-long study, commenced experimenting in a thoroughly methodical manner. After six years, during which time several hundred flights were made, Lilienthal met his death whilst trying out a method of control designed to facilitate soaring flight.

Lilienthal had a large conical hill built, with the earth excavated from a canal being constructed nearby, and from the top of this the launches were made. Several machines, both monoplanes and biplanes, were constructed and tested, and at times Lilienthal succeeded in rising above his starting point, and thus achieved the earliest known soaring flights.

Lilienthal was convinced that if he could manage to turn after taking off, a prolonged soaring flight would be possible. How true present-day knowledge shows his theory to have been! His next step was to fit an elevator control, but unfortunately he became confused in its operation and fell to his death in August, 1896.

There is no doubt that Lilienthal, more than any other, laid the foundations of flight, and particularly of gliding and soaring.

History now reverts again to England where Percy Pilcher continued with Lilienthal's mission, after having collaborated with him to some extent. Pilcher greatly improved the stability of his gliders by the addition of a fixed tail plane and vertical rudder; the first step towards the present day control system. With the 'Bat' and the 'Hawk', built to incorporate these units, he made some quite long flights. However, he also met his death in 1899, through the collapse of his machine whilst being towed by a team of horses through a speeding-up gear.

Chanute, an American engineer and another of Lilienthal's disciples, persevered. He soon condemned the original type of bat-wing glider and evolved a superior machine with tail surfaces, with which he carried out about 600 glides. Chanute also had a firm belief in pure gliding flight, and saw a future for soaring machines capable of long distances without the aid of motors.

The final link of the chain forming the accomplishment of heavier-than-air flight was forged by the brothers Wright, also in America. After making a careful study of the works of Lilienthal, Chanute, Pilcher and Professors Maxim and Langley, who had contributed towards the solution of powered flight, they commenced their four years of activities which culminated in 1903 with the first power-driven flight.

Lilienthal had brought the 'natural' stability type of aircraft, in which balance was retained by movements of the body, to a very advanced stage; Pilcher and Chanute had added directional and stabilizing planes to give automatic stability; and finally the Wrights

made their control surfaces moveable. The stabilizing plane, or elevator, was moved out to the front of the main planes, whilst the wing-tips were made to work as ailerons for lateral control.

In principle the controls were identical with those in use to this day, so that success could no longer be withheld. Attempts were first made to fly the machine as a kite with one of the Wright Brothers on board, but, being unable to rise by this method, they turned to gliding down the sand dunes at Kitty Hawk. Distances of over three hundred feet were soon accomplished, at which stage the third and last control, the vertical rudder, was added to work in conjunction with the warping wings.

Other detail perfections followed, and during the two months September and October, 1902, nearly one thousand flights were carried out, the length increased to six hundred feet, and winds of up to thirty-six miles an hour had been successfully encountered. By the following autumn several flights of one minute duration had been

achieved, including a number of soaring flights in which the glider was made to hover over one spot, without loss of height, for several seconds.

The Wrights had produced a flying machine controllable in all three dimensions and had thoroughly mastered the art of flying and soaring. At this stage they fitted an engine, and by making the first power-driven flight thus concluded their contribution towards the solution of soaring flight.

Gliding history now returns to France, where Voisin, Archdeacon, and Ferber built a box-kite glider with which some flights from hills were first made, and then they introduced towed-flight with the aid of a motor car. Voisin and Bleriot also experimented with a seaplane glider on the River Seine and on Lake Geneva.

In England Jose Weiss and Dunne built gliders which incorporated inherent stability in their design, though the methods employed were not the same, and both met with considerable success.

The last chapter opens in Germany, where

fourteen years of steady progress has been made. The resuscitated movement spread with renewed energy throughout England, America, France, Russia, Poland, and Italy, and more recently it has been taken up in Australia, New Zealand, Africa, and India, so that it is rapidly becoming recognized by the whole world as an established branch of aviation.

By the Treaty of Versailles certain limitations were imposed on Germany which largely prohibited the construction of aeroplanes, and this led the German Government to subsidize motorless flight, with the fortunate result that interest in this important branch was greatly stimulated.

In August, 1920, a gliding meeting was held in the Rhön Mountains at which the best flight, exceeding five minutes in duration, was made by Klemperer, and the machine, a cantilever monoplane constructed largely of plywood, was the forerunner of the present-day sailplane. The following year Wasserkuppe was again selected for a competition, and a flight extending to two and a half miles,

the record up to that time, was recorded. After the close of the competition Klemperer succeeded in remaining aloft for over thirteen minutes, covering a distance of six miles, whilst Harth carried out a flight of twenty-one minutes in which he reached a height of four hundred feet and landed again at his starting-point. These performances were the beginning of genuine achievement and showed that the usefulness of gliders had not come to an end with the development of the power aeroplane.

In 1922 the duration record was raised first to one hour six minutes by Martens, to over two hours by Hentzen, and again by Hentzen to more than three hours. The interest of other nations was stirred by these successes, with the result that meetings were held in both England and France. Nothing of note was accomplished at the French meeting, but at Itford Hill, in Sussex, Maneyrol broke the duration record with a flight of three hours and twenty-one minutes, besides which many other noteworthy flights were made.

During the past four years, duration, altitude

and distance records have been repeatedly broken by very considerable amounts with flights of truly remarkable performance.

Cloud sailing was initiated by Nehring and Kronfeld, with the result that distances of one hundred miles (measured in a straight line) became commonplace. This was followed by thermal soaring by Hirth and Groenhoff, which has been the means of enabling the distance to be extended to well over two hundred miles.

Altitudes of up to 13,000 feet have been reached and duration flights of 36 hours.

Hence it is seen that gliders were first used for establishing the principles of flight, followed by the solution of the problem of stability, and finally the perfection of a proper control system so that the aeroplane became an established fact. After some years of almost complete neglect, the glider was improved in design and efficiency with the ultimate evolution of the high performance sailplane.

To-day the problems of motorless flight are receiving more and more attention, and every

day brings more adherents to its cause. Already the achievements stand out in the forefront of aeronautical and scientific development, whilst the possibilities opened up are full of promise.

CHAPTER II

ELEMENTARY AERODYNAMICS

Before actually commencing to fly it will be well to obtain a good general knowledge of the principles involved by the flight of a glider, together with the functions of the control systems and their effect on the flight path ; for unless the pupil is able to visualize the action of all control movements and the nature of the air flow past the wings and other parts, he is not likely to make an efficient pilot of any type of aircraft.

Let us first consider how it is possible to support a glider (or other heavier-than-air craft) in the thin air, without sinking directly through, as it might be reasonably expected to do.

Most of us have momentarily supported flat stones and other heavy objects on water, by skimming them over the surface, and it was noticed that each time the stone hit the

water it glanced off into the air again until so much speed had been lost that it finally sank.

The two principles are exactly similar and introduce the basic and important factor of speed. So long as the glider, and the stone, retain speed above the critical amount, they will remain supported; but as the speed is reduced there is found to be a certain velocity at which sinking takes place. This is known as the *stall* and will be more fully discussed later.

There are slight differences between the glider and the analogy given, in that the glider derives a constant supporting force, whereas the stone receives a series of lifting reactions during impact only, and also the glider is immersed in air whilst the stone moves on or above the surface of the water; but in both cases prevention from sinking is dependent on speed.

The glider consists, fundamentally, of one main plane (or two in the case of a biplane) and a number of auxiliary planes (Fig. 1) which are necessary for guiding the main

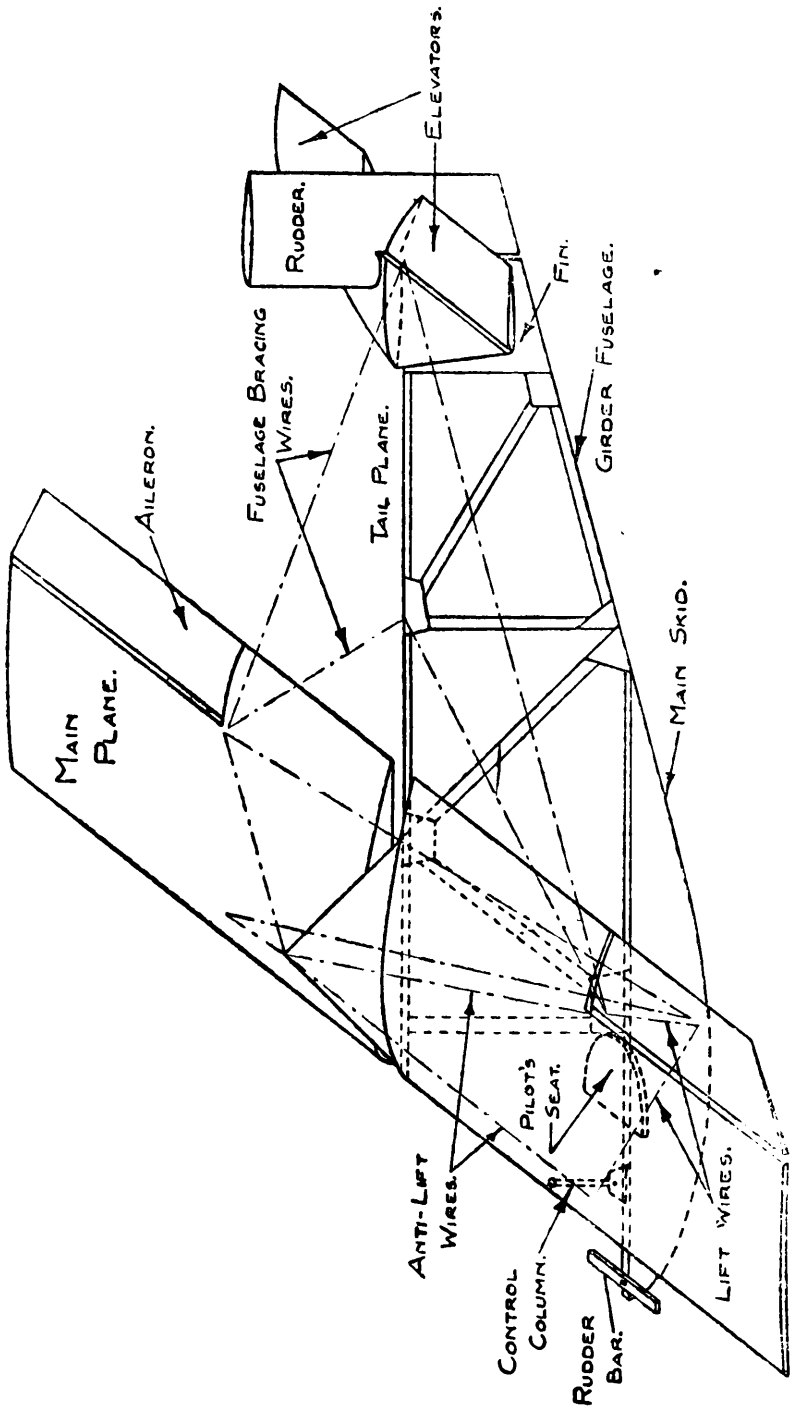

FIG. 1.—Elementary Glider and Nomenclature of Main Components.

plane and for preserving balance, *but the action of all is the same* and is based on the forces that it is possible to obtain by a moving stream of air when directed on to a flat, or cambered, plane at varying angles of attack, or incidence. Whether the plane is stationary with the air moving or vice versa makes no difference.

It is, therefore, necessary to examine the action and reaction between a flat plane and a stream of air, remembering that the effect of the plane on the air is just as important as the forces exerted on the plane by the airstream.

Airflow past Flat Plate.—Figure 2 shows the airflow past a flat plate when held at different angles to the direction of the airstream. At (a) the plate is parallel to the flow, and, neglecting surface friction, the flow remains unaltered so that no forces are set up. Now let the plate be inclined at some small angle to the airstream, as at (b), when it is found that the streamlines tend to follow the direction of the plate, or, in other words, they are deflected downwards.

A mass of air is thus being forced from its

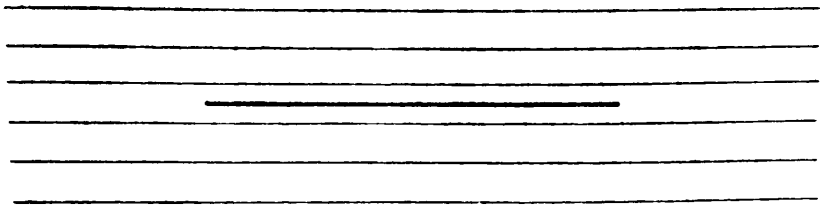

(a)

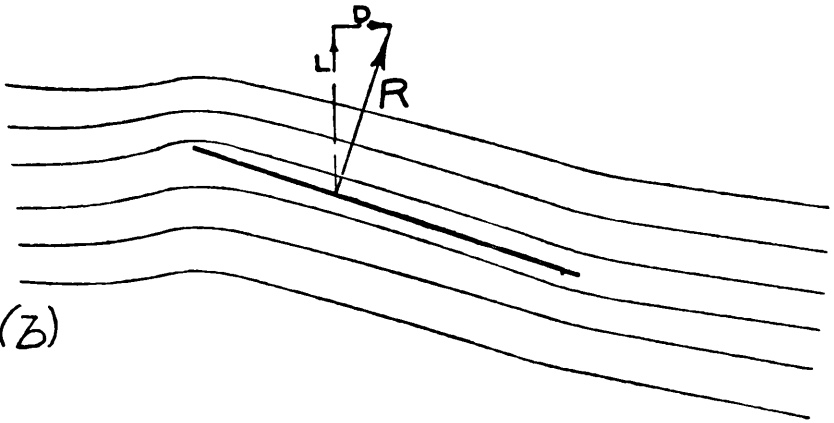

(b)

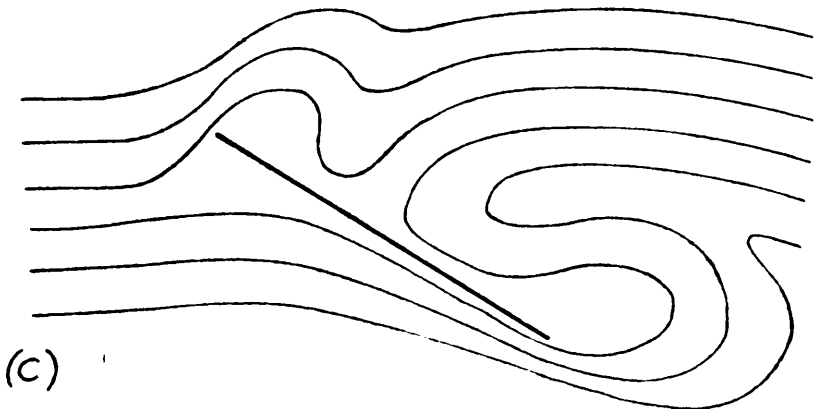

(c)

FIG. 2.—Airflow past Flat Plate.

original direction and receives a downward impetus, causing, at the same time, a force, R , to be exerted on the plate, such that the two forces are equal in magnitude but opposite in direction.

As the inclination of the plate to the airstream is increased, so the force exerted on the plate (which incidentally is the force that is required to hold the plate in position against the airstream) increases, until, what is known as, the *critical angle* is reached. At this point the air refuses to conform itself with the direction of the plate so that a breakdown in flow takes place and disturbed conditions are set up, as shown at (*c*).

These conditions are known as the 'stall', and take place at an angle of about 15 degrees with most wing sections. Any increase in the angle, above this point, results in greater turbulence and consequently, for normal flying, we are only interested in what takes place at angles below the critical.

The Aerofoil.—The earliest types of gliders were built with flat planes as aerofoils, but it was found that if the surface were slightly

curved, or cambered, better results were obtainable. Also the wing had to be supported by means of spars and so the double cambered wing was produced in order that the spars could be housed between the upper and lower surfaces. Instead of having a detrimental effect on efficiency this development actually proved to be beneficial, which

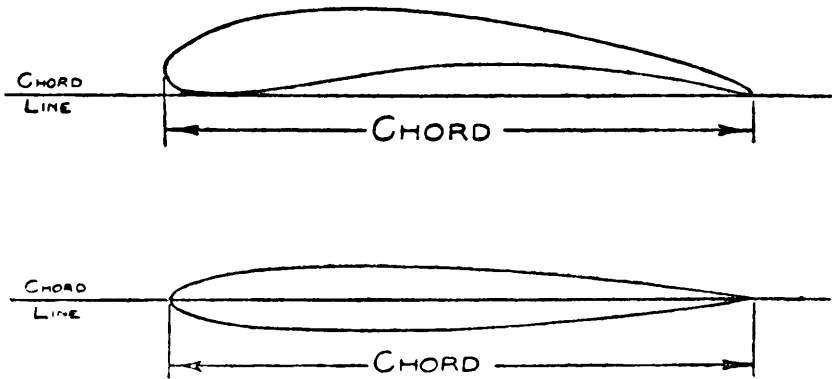

FIG. 3.—Aerofoil Sections.

is hardly surprising, since the shape of the section thus evolved more closely resembles that of a bird's wing.

The present-day thick sections, used extensively for sailplanes, represent a still later development and constitute a very valuable feature in the design of soaring aircraft, since they possess certain characteristics eminently suitable for flight with this type of machine.

We will now analyse further the force on an aerofoil when subjected to a stream of air.

The total air force, already referred to, and denoted by R , acts in a direction approximately at right angles to the chord line of

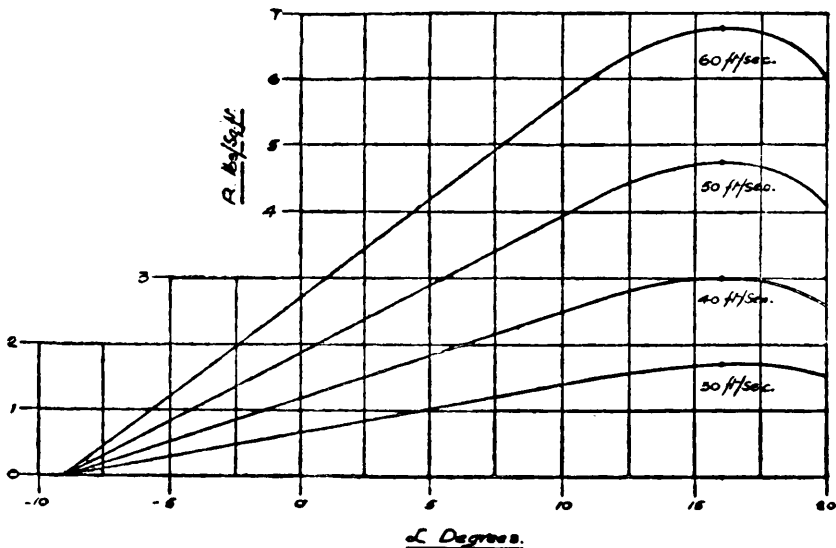

FIG. 4.—Air Reaction on Wing at Various Speeds.

the wing for the normal range of angles of attack. (The chord line being in some cases the line joining the leading- and trailing-edges, and in others, of bi-convex section, the line touching the section near the leading- and trailing-edges, see Fig. 3.) Figure 4 shows, for one wing section, this force plotted against

incidence for angles from -9° to $+20^\circ$, for various speeds of airflow.

For the sake of convenience it is usual to split up this force R into its components which act in directions perpendicular, and

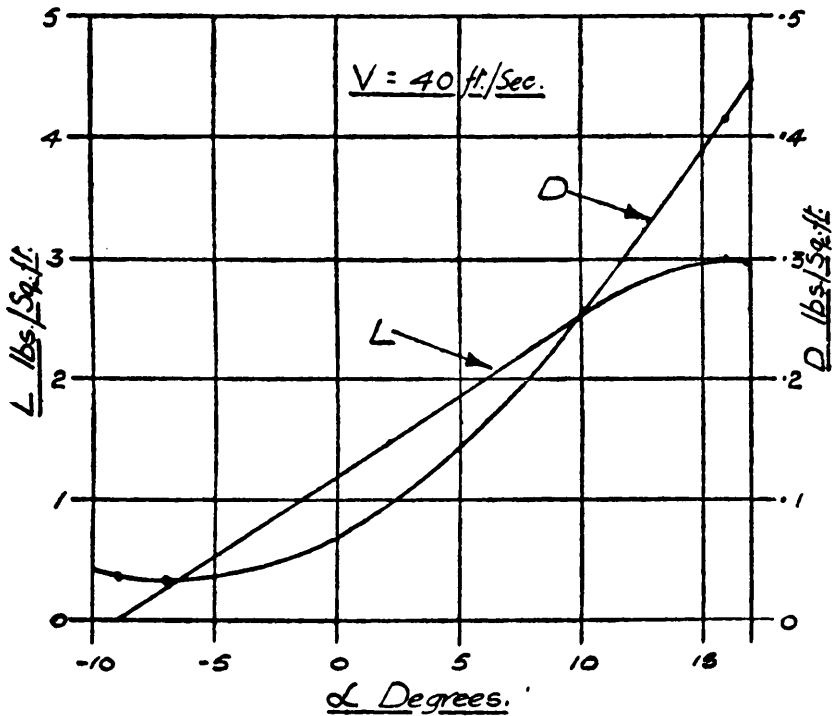

FIG. 5.—Lift and Drag Forces on Wing.

parallel, to the direction of the airstream. (See Fig. 2 (b).) These are called lift, L , and drag, D , and this has been done for one speed of flight in Fig. 5.

This diagram, then, shows the forces that

will be exerted vertically and horizontally when the aerofoil, or wing, is held against an airstream moving horizontally with a speed of 40 ft per second, for the range of angles given.

Thus, for example, if the angle of incidence is 5° the lift force is 1.8 lbs per square foot and the drag load is 0.15 lbs per square foot.

In Fig. 5 it will be noticed that some lift



FIG. 6.—Airflow over Wing at Zero Incidence.

is present at 0° incidence, and does not vanish until -9° for this particular aerofoil section. This is usual for most aerofoils and is due to the fact that, when the chord line is horizontal, the airflow is still deflected downwards to some extent (see Fig. 6).

Effect of Speed.—It has already been seen that there is a critical speed below which the glider will cease to travel along a forward

path through the air, but, instead, will commence to sink vertically, referred to as the 'stall', and also when considering the flow of air past a flat plate it was seen that the flow broke down at a certain critical angle.

Now it has been found, experimentally, that *the total air force, R , varies directly as the square of the air speed*, which means that, at any one angle of incidence, if the air speed is doubled the forces present are quadrupled, or correspondingly a decrease to half the velocity reduces the lift and drag to one quarter of the original amount.

For the example given above, therefore, we see that for speeds of 30, 40, 50 and 60 ft per second, the wing force would be 1.05, 1.8, 2.85, and 4.2 lbs per square foot respectively (Fig. 4). Notice also how when the speed is doubled, *i.e.* increased from 30 to 60 ft per second, the maximum wing reaction is increased from 1.68 to 6.76 lbs per square foot, or four times as much.

A glider weighing 400 lbs and with a wing of 200 sq ft area, gives a loading of 2 lbs per sq ft. Figure 4 shows that this figure can

be obtained at a wing incidence of -2.5° for a speed of 60 ft per second, increasing to $+0.5^\circ$ at 50 ft per second and 6.0° at 40 ft per second, and that support would be impossible at 30 ft per second. In other words the glider would stall at a speed greater than 30, but less than 40 ft per second.

So far, then, we have seen that the air forces acting on an aerofoil can be varied either by altering the angle of attack or by a change in the speed of airflow and we will now investigate the application of these principles to a glider in normal flight.

Forces on a Glider in Steady Flight.—The forces acting on a glider in normal steady flight are the weight, W , and the total air force, R , and these must be equal and opposite in direction, that is to say, since the weight always acts downwards in a vertical direction, therefore the total air force must always act upwards (see Fig. 7).

If R were greater than W , then the glider would have to rise; or, alternatively, if R were less than the weight, then the glider must sink, which means that for steady flight *the*

air force acting must always equal the total weight of the glider.

Now, except for a short climb following a dive, it is impossible for a glider, or sailplane, to fly without loss of height *relative to the air* in which it moves, and therefore, *during the whole of a flight, whether gliding or soaring, the*

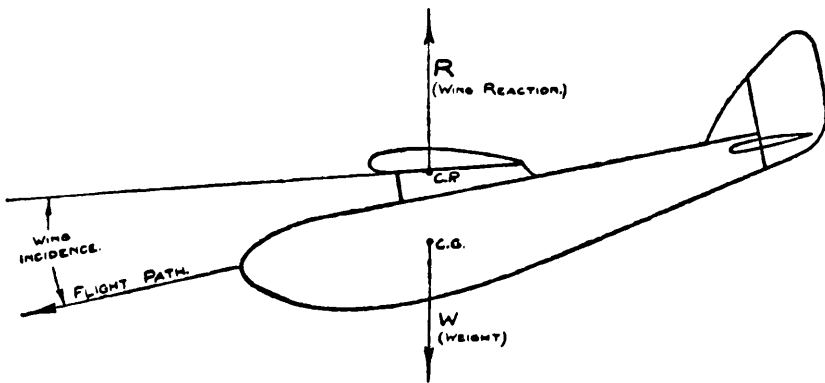

FIG. 7.—Forces on Glider in Normal Flight.

glider is descending through the air and can only retain its height relative to the ground if the air is moving upwards.

Since, therefore, all soaring is gliding, we will exclude for the time being what is generally known as soaring flight and confine our consideration to gliding flight in still air, or in air having horizontal movement only.

It has been shown that the air forces acting can be varied by changing either the speed or the incidence of the wing, and since, for steady flight, the total air reaction must always remain equal to the weight of the glider (which does not vary during a flight), *any change in speed must be accompanied by a change of the angle of attack of the wing and vice versa.*

For example, consider the sailplane, at (b) in Fig. 8, gliding downward at a steady speed which the pilot wishes to reduce to a lower speed. If this could be done, say, by means of air brakes, without altering the angle of attack, then the air forces would decrease and the sailplane would sink. Therefore, in order to retain the supporting forces at the lower speed, the wing must be inclined to the air-flow at a greater angle, giving the new conditions as at (a).

There is obviously a point beyond which this process cannot be continued, and is caused by the breakdown in airflow previously referred to.

This, then, is *the stalling, or minimum flying speed, and takes place when the wing makes the*

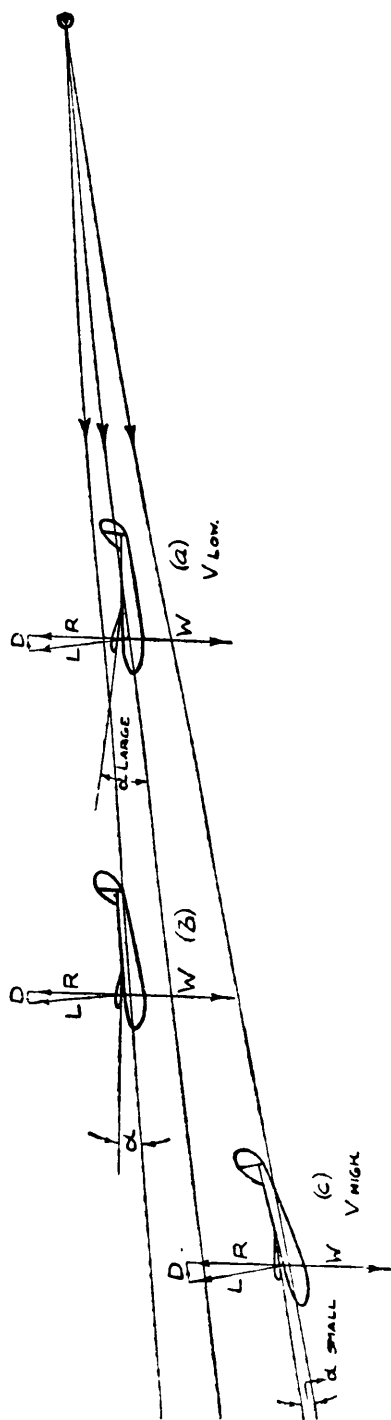

FIG. 8.—Speed and Incidence.

- (a) Minimum Sinking Speed.
- (b) Finest Gliding Angle, i.e. Greatest Distance for Given Loss of Height.
- (c) Greatest Distance in Given Time.

maximum possible angle with the direction of motion, without causing a breakdown in the streamline flow.

Lift and Drag.—It has already been mentioned that it is convenient to split up the total air force on an aerofoil into components acting perpendicularly and parallel to the direction of airflow, known as lift, L , and drag, D . For a glider descending through the air, the path of the machine obviously determines the direction of the airflow on to the wing and therefore L is measured perpendicular to the path, and D , directly along the path. This latter force tends to retard the glider's motion along the path, and, under normal steady conditions, prevents any increase in speed.

Referring back to Fig. 8, it will be seen that D is smaller at (*b*) than it is at (*a*) but that a further increase in speed, as at (*c*), results in D being larger again.

Also, since R remains unchanged in magnitude, L must be greatest when D has its least value, and is then nearly equal to R .

The best gliding angle is obtained when L/D is a

maximum, or in other words, this is the position which enables the greatest horizontal distance to be covered for any given loss in height, this condition being shown at (*b*). Notice also that

$$\frac{\text{Horizontal distance}}{\text{Loss in height}} = \frac{L}{D} = \text{ratio of descent.}$$

If now a further increase in speed is desired, the angle of descent must be increased ((*c*) Fig. 8), and a greater horizontal distance will be covered in a given time than under conditions (*b*), but only at the expense of a much greater loss in height. Such flight is not of much use in gliding, or soaring, except when flying against head winds or for landing purposes.

CHAPTER III

THE CONTROL SYSTEM

In the previous chapter it was stated that the glider consisted of a main plane and a number of auxiliary planes and that the action of all is based on the same principles. The method of obtaining lift and drag on the main plane has also been explained, so we will now examine the functions of the various control surfaces.

Axes of Movement.—There are three axes of movement (see Fig. 9) which are mutually perpendicular and pass through the centre of weight of the glider.

The *Rolling*, or longitudinal, axis, can best be imagined as though a rod were passed down the centre of the fuselage longitudinally, and about which the machine is free to rotate.

The *Pitching*, or lateral, axis could be demonstrated by placing a rod parallel to the main plane and passing through from one side of

the fuselage to the other so that the glider could be made to turn a somersault about the fixed rod.

The *Yawing*, or turning, axis would then be shown by a rod fixed vertically, with the

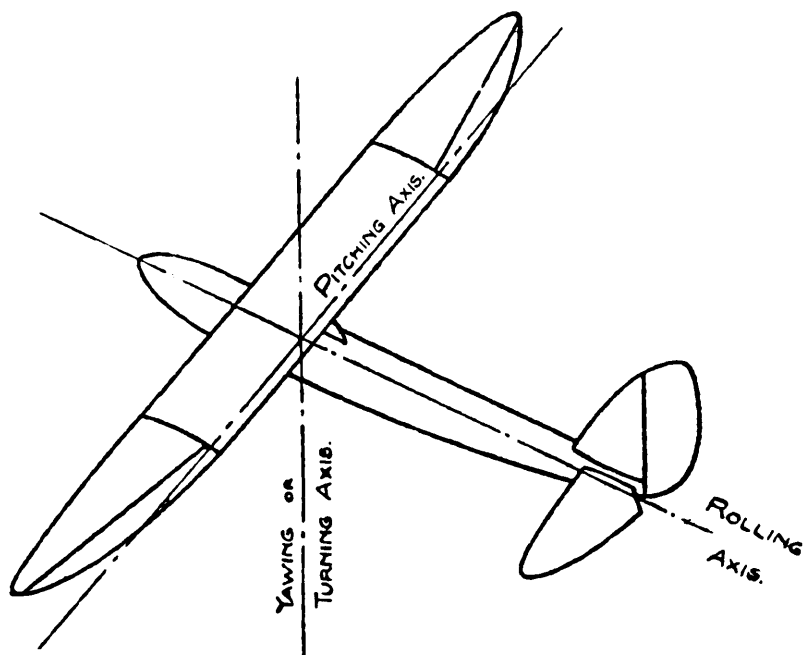

FIG. 9.—Axes of Movement.

machine in a normal flying position, so as to pass down through the fuselage from top to bottom.

Movement about the rolling axis is governed by the ailerons situated on the wings, pitching

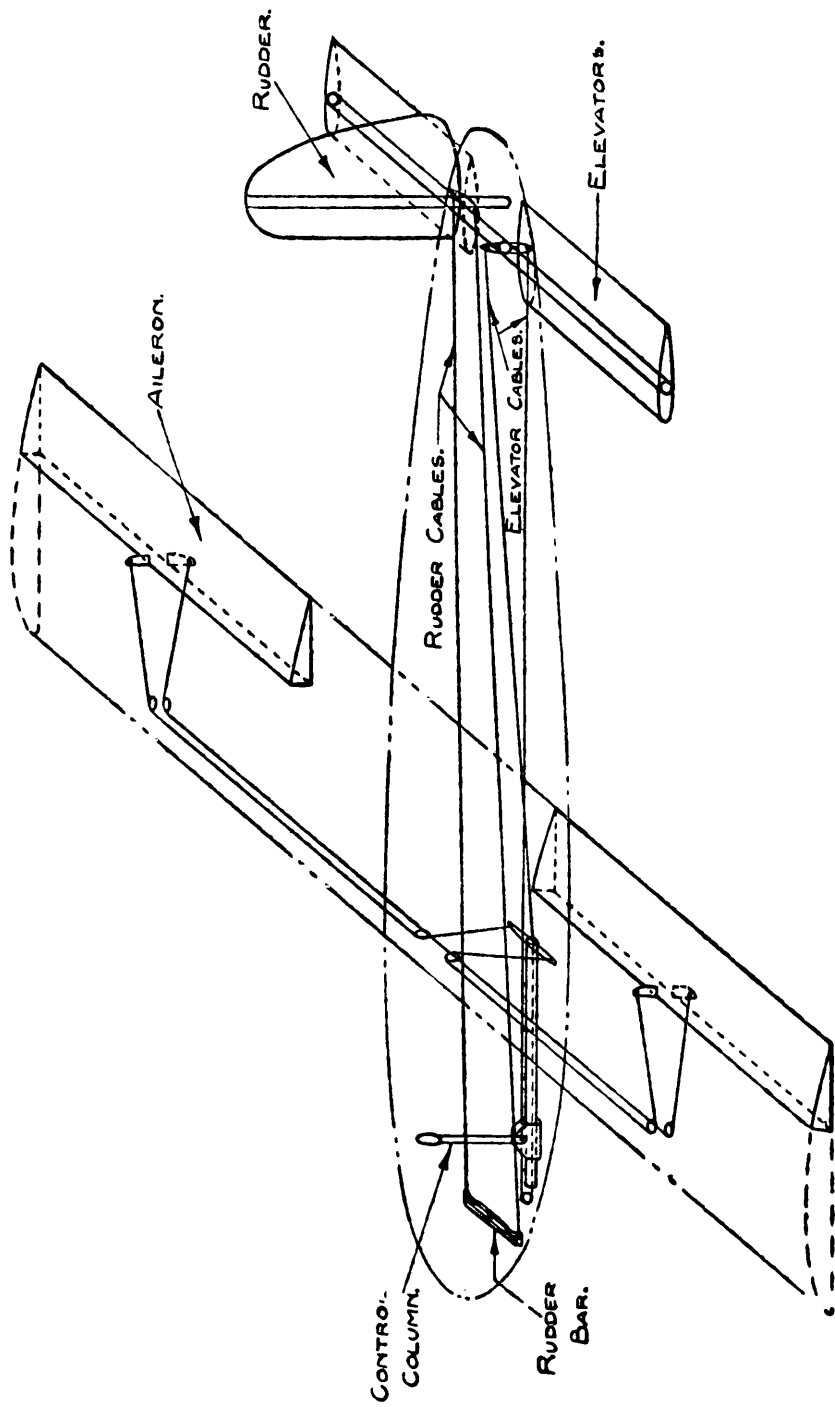

FIG. 10.—Control System.

is controlled by the elevators, while the rudder is used for yawing.

Figure 10 shows, diagrammatically, the control system and how it is operated by the pilot.

The Tail Plane.—This is a fixed horizontal surface, fixed at the rear of the glider, and serves a dual purpose, *i.e.* its primary duty is to provide longitudinal stability, but also it assists in the elevator control.

In discussing the forces obtainable on an aerofoil no mention was made of the position through which the force, R , acts, and if this always remained constant, say at the middle of the chord, both design and piloting would become much simpler; but unfortunately this is not generally the case.

The centre of pressure, C.P., is in its most forward position, about one-third chord from the leading edge for most aerofoils, at the maximum angle used in normal flight, say 15° , and moves steadily back towards the trailing-edge as the angle is decreased and, of course, the speed is increased.

This backward movement tends to lift the trailing-edge and thus still further to decrease

the incidence, or, in other words, any such change in the attitude of flight when once started, through some local disturbance in the air, for example, is aggravated by the C.P. movement.

Now consider the action of the tail plane when the nose of the glider has been temporarily depressed. Since the tail plane is fixed the incidence must also be decreased, correspondingly as the main plane, and hence the lifting force on it is reduced, or becomes negative, so that it tends to fall also and thus overcomes the unstable motion of the main plane. The area of the tail is much less than the area of the main plane but its distance from the centre of weight of the whole machine is much greater than is the distance of the wing C.P. and hence its effect, or moment, is greater.

The action explained above is not quite complete in itself, as the two forces brought into play, namely the pitching movement exerted on the main plane by the shift in the C.P. position and the corrective force of the tail plane, are not evenly balanced throughout

the range of angles of flight and therefore it has to be supplemented to some extent by means of the elevator.

So far then, the tail plane has been investigated as a means of providing longitudinal or pitching stability. Its function as a control must be considered in conjunction with the elevator.

The Elevator.—The main purpose of the elevator, or elevators, which form the rear, or hinged, portion of the tail plane is to control the machine about the lateral axis ; that is to say the angle of glide is determined by the position of the elevator.

Thus, if the pilot wishes to dive at a steeper angle, the control column is pressed forward, which depresses the elevator and, by increasing the lift on the tail plane and elevator, causes the tail to rise relative to the main plane.

In normal flight the elevator generally forms, with the tail plane, a symmetrical aerofoil section, the whole being set at zero incidence to the airflow so as to create no lift and the minimum of drag. Movement of the elevator from the neutral position changes the shape

to a cambered section, at the same time increasing the incidence angle, and thus builds up lift over the whole surface. This lift is positive or negative according as to whether the elevator is depressed or raised.

It should be noticed that in setting the tail plane in the 'no lift' position the downwash from the main plane, explained in Chapter II, has to be taken into account.

Many sailplanes are constructed with the whole tail plane hinged to form one large elevator (or two elevators if split by the fuselage); the fixed tail being dispensed with altogether. This in no way upsets the principles explained above but means that the pilot must use the elevator for retaining stability, as well as for manœuvring, with a resultant increase in the degree of sensitiveness of the control.

Fin and Rudder.—The action of these control surfaces is very similar to the tail plane and elevator in that they provide stability and control about one of the axes, the vertical, or turning, axis.

Suppose a glider is turned off its course by

a temporary change in the wind direction or other cause, so that although *it still continues*

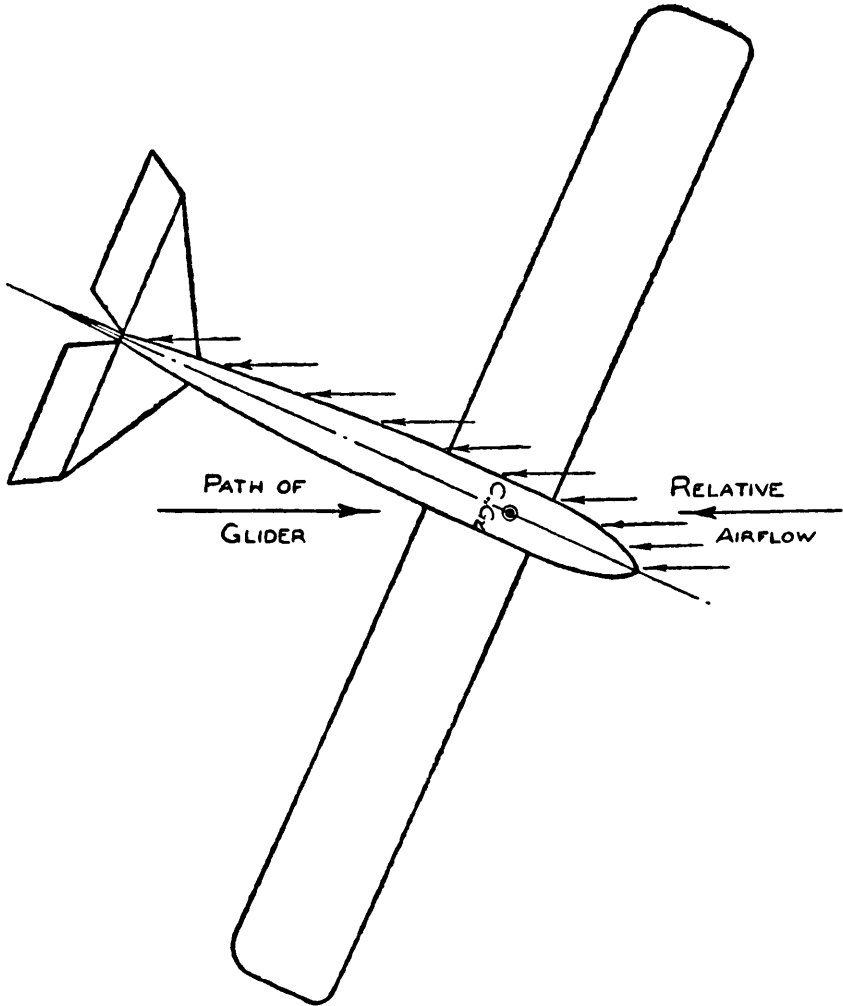

FIG. 11.—Directional or Weathercock Stability.

along the original path, one side of the body is presented to the relative air flow (Fig. 11).

Then the air force forward of the centre of weight, or centre of gravity as it is termed, is tending to turn the nose still further from its original course, while the air resistance over the rear parts tends to restore its position to the proper flight path.

The turning effect of each force is obtained

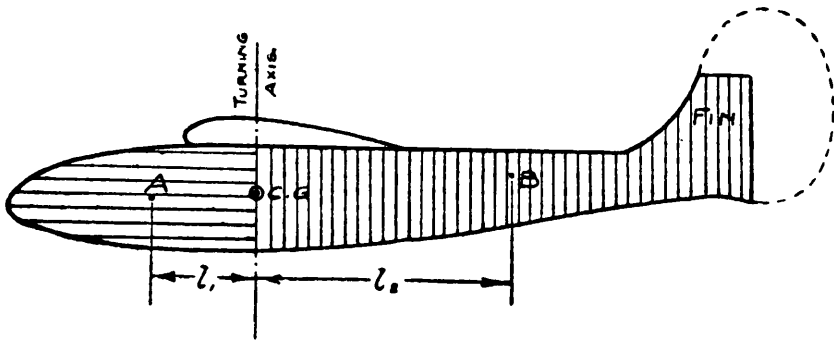

FIG. 12.—Directional Stability.

by multiplying the area by the distance of its centroid from the turning axis, and for stability the area A multiplied by l_1 (see Fig. 12) must be less than area B multiplied by l_2 . This is often called 'weathercock' stability.

The rudder is hinged to the fin and is pulled over to one side by the pilot exerting a force

on the rudder bar. This sets up a force on the rudder and its fin, which 'lifts', or pushes, the tail to one side, thus tending to turn the nose in the desired direction.

However, unless the glider is banked to some extent, *i.e.* the wings are inclined about the longitudinal axis so that the wing outside the turn is raised, the machine will be forced to slip sideways and the turn will not be properly executed. This is considered under the heading '*Ailerons*'.

The remarks relating to the case of no fixed tail plane apply also when there is no fixed fin, except that the difference in sensitiveness is much less marked.

Ailerons. — These are hinged flaps at the rear of the main planes and extend over the outer portion of the wing. In some cases they are situated along the whole span.

They are so connected that sideways movement of the control column raises the aileron on the side to which the column is moved and depresses the other. This has the effect of decreasing the incidence, and hence lift, on the

one side, with a corresponding increase of both on the other side, so that the wing on the outside of the turn is raised.

It will be easily seen from Fig. 13 that the

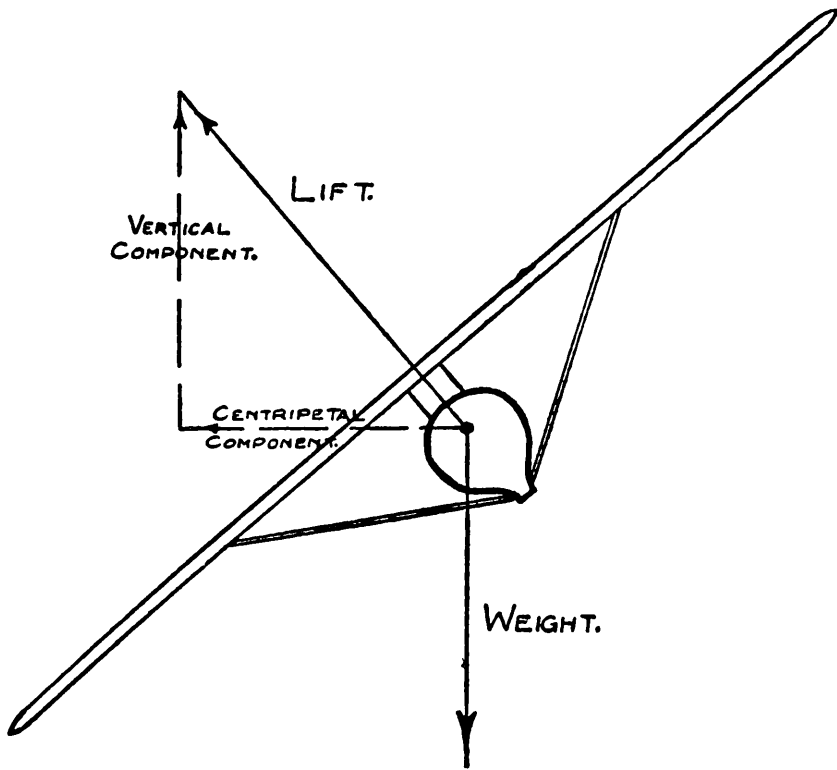

FIG. 13.—Forces in a Turn.

lift force acting on the main plane is now inclined inwardly towards the axis of the turn and it is the horizontal component of this force which overcomes the tendency to sideslip outwards, caused by centrifugal force.

The amount of bank required naturally depends on the radius of the turn, the bank being steepest for rapid turns.

In sailing flight it is preferable, where possible, to make gentle turns with a little bank only in order to avoid loss of the vertical component of lift.

CHAPTER IV

ERECTION AND RIGGING

These notes refer principally to elementary training gliders, but apply also to some extent to soaring machines and sailplanes. The methods of erection of the advanced machines are generally fairly obvious and peculiarities of any particular type are usually explained by the manufacturers.

Assembly.—We will assume that the glider has arrived in its dismantled state and is ready for assembly. The component parts may be laid out on the leeward side of the hangar or shed, or in some position by a tree, or haystack that is sheltered from the wind. The left, or port, wing should be placed on the left, with the starboard wing on the right of the fuselage, and the tail units behind so that they will be handy when required.

Any struts and wires should be placed in their approximate positions and all pins, locking



THE "FALCON" INTERMEDIATE SOARING GLIDER.

pins, etc., may be placed in a box in readiness. A hammer, a screwdriver, and a pair of pliers may be required. (A full kit of tools should be available and should include drills, wire and sheet metal cutters, saws for metal and wood, planes, chisels, files, etc.)

If the machine has flying, anti-flying, and rigging wires they will most probably be attached to the fuselage in their respective positions and coiled up.

The fuselage should first be held up so that it stands on its skid, when one of the wings can be lifted by one person at the wing tip and two at the root, carried into position, and the fixing pins inserted.

The anti-flying, or landing, wires are then uncoiled from the pylon, or cabane, and attached to the upper surface of the wing so as to support it, but the wing-tip man remains holding the wing level. The other wing is attached in the same way, and all flying wires are loosely connected (Fig. 14).

Where the wings are supported by struts instead of wires, these may be attached to the fuselage and left with their outer ends resting

on the ground. As each wing is fixed in position by the root-end pins, the struts are lifted and attached.

The tail plane is next placed in position, the bolts or pins fixed, and the wires, or struts, attached, after which the elevator and rudder are fitted.

Rigging wires from the wings to various

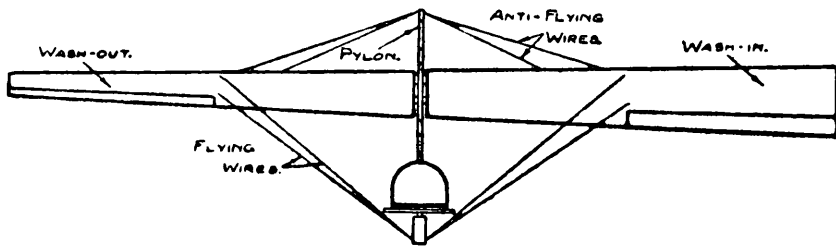

FIG. 14.—Truing up Glider.

points on the fuselage should be connected up, but left fairly loose. All wires are fitted with turnbuckles, which consist of a barrel with internal threads, left-hand one end and right-hand the other, which screw on to threaded eye ends so that when the barrel is turned one way both threads are screwed up. An important point when connecting up is to first detach the turnbuckle and then screw it on to one end by one thread only, when the other end should be engaged.

If the amount of thread that has entered the turnbuckle ends is unequal, there is a loss in the amount of available adjustment, besides which the joint may not be up to the required strength.

A little oil on all threads will greatly simplify assembly and, more important, facilitates subsequent adjustment and dismantling.

Truing up.—The whole structure may now be trued up and rigged for flight; first consideration being given to the main planes. For this purpose the fuselage should be held quite vertical and the turnbuckles on the top (anti-flying) wires screwed up until the leading edges of both planes form one continuous line. This can be done by eye first, by looking along the leading-edge from one wing-tip, and then by standing directly in front, but a few paces forward, of the fuselage to make sure that the planes are perpendicular to the fuselage, or horizontal with the ground when the body is vertical; any necessary adjustment being made by the turnbuckles on the front wires (see Fig. 14).

Incidence.—Next the incidence must be

checked along the whole span. The trailing-edges should be in alignment, but even so it is still possible for the incidence to increase towards one tip (known as wash-in), and to decrease towards the other wing-tip (wash-out).

Flight with a machine rigged in this condition is most unpleasant and dangerous, and if the difference in incidence is sufficiently pronounced it may be impossible to execute turns towards the side which has wash-in.

The main planes are generally set so that they make some small angle with the normal line of flight; the leading-edge being higher than the trailing-edge. This is known as the fixed angle of incidence.

A simple device for checking the incidence consists (Fig. 15) of a straight lath to which is attached a semi-circular piece of stout card, or plywood, and a plumbline. The lath is first placed across, or under, the spar roots and the position of the string on the card is marked with a pencil. It is then taken to one wing-tip (which is usually provided with a straight member for this purpose) and held against the tip member. If the string is now in front of

the pencil mark there is a decrease in incidence or wash-out, and this should be rectified by letting out the rear anti-flying wire. Alternatively, any tendency towards wash-in, indicated by the string falling behind the pencil mark, should be put right by tightening the rear wire. The other wing is then treated in

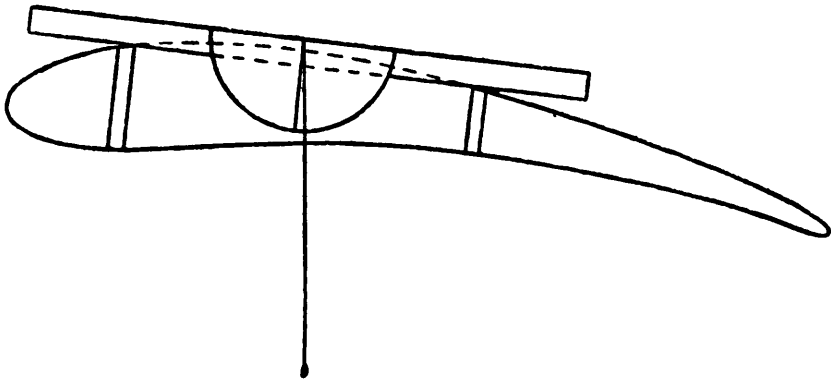

FIG. 15.—Incidence Board.

a similar manner after which both leading and trailing edges should be again checked for alignment.

It may be mentioned that the angle made by the string with the 90° position on the incidence board will only equal the true incidence angle if the fuselage is held in correct flying position. There is, however, no need

for this to be the case as the incidence at the roots is determined by the attachment fittings so that it is only necessary to line up the wings with this point.

Once the alignment and incidence have been correctly adjusted the lower, or flying, wires should be just tightened so that there is no slack. If any of these wires are over-tightened there will be initial stresses in both the wires and the spars, with the probable result that failure will take place in the event of a heavy landing, whilst collapse in the air is not impossible.

The turnbuckles on the wires should now be locked by threading a short length of copper wire through the hole in the barrel and passing the ends through the eyes at the ends and twisting them round in two or three turns.

All this work is not necessary where struts instead of wires are employed as the struts set the planes at the correct angle automatically.

It may be worth pointing out that struts are more liable than wires to fracture when subjected to the impact loads of heavy landings, and it is owing to the 'give', or elasticity, of

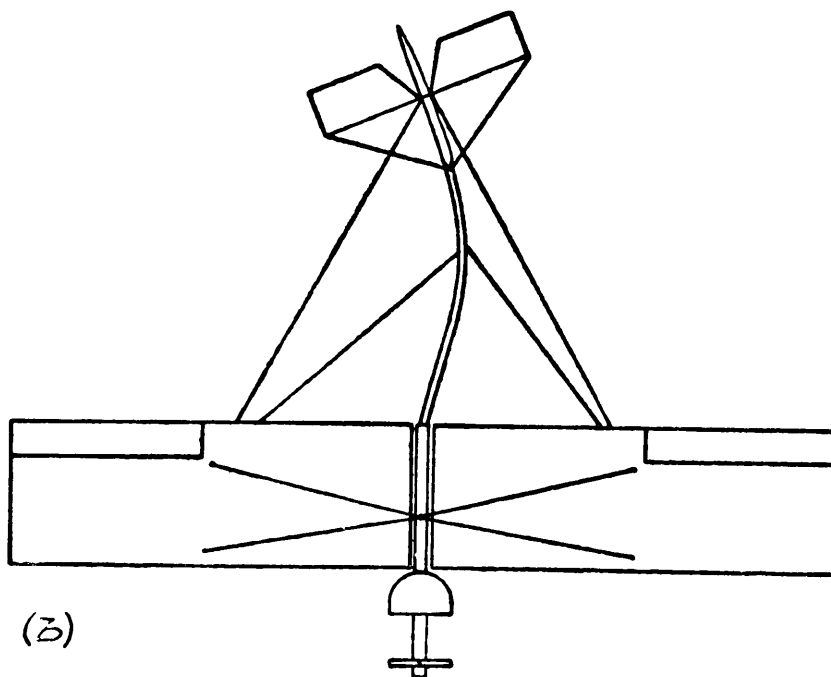
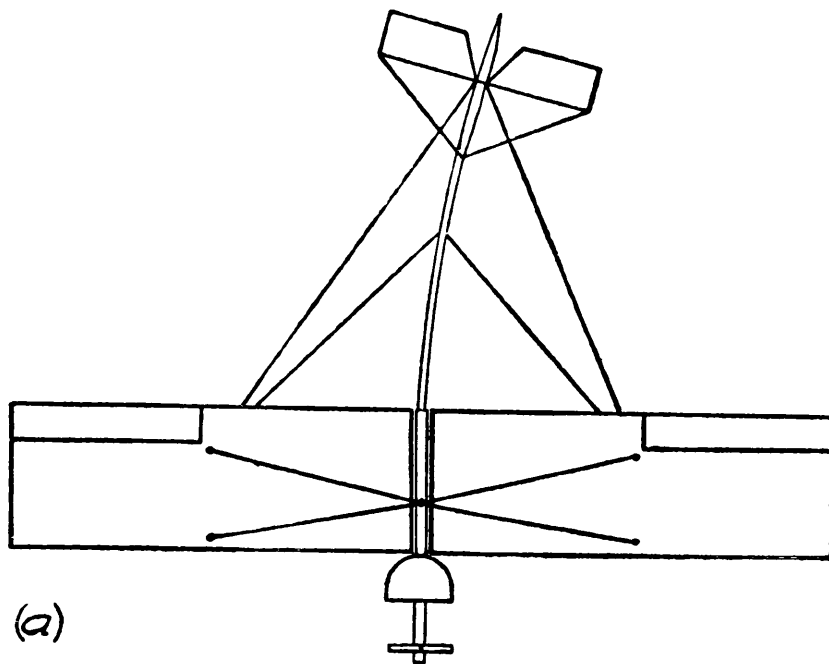

FIG. 16.—Rigging Faults.

wires that this form of construction is so much favoured for training machines.

Fuselage and Tail Rigging.—The fuselage rigging wires are the next to be adjusted. The turnbuckles should be tightened until there is no droop left in the wires, when the fuselage framework, as viewed from the front, should appear as one vertical strut. Common faults are shown exaggerated in Fig. 16 (*a*) and (*b*). In the former cases the wires on the side to which the tail is pulled should be slackened off and the opposite wires tightened correspondingly, whilst in the latter the shorter wires need adjusting in a similar manner, whilst both tail wires may need lengthening slightly.

The tail supporting wires may now be adjusted so that the tail plane appears parallel to the main planes when viewed from the front with the rudder and fin vertical; after which all rigging wires should be properly locked as explained previously for the main plane wires.

Controls.—The flexible cables may now be connected to all control surfaces and adjusted. The ailerons are usually attached to the wings

when delivered and these are held in position temporarily by two small strips of wood held together by a screw (see Fig. 17). These clips should be retained as they will be found useful if at any time the wings are to be transported.

The aileron clips need not be removed until the cables have been preliminarily adjusted with the control column held in the central position, but they should be taken off for the

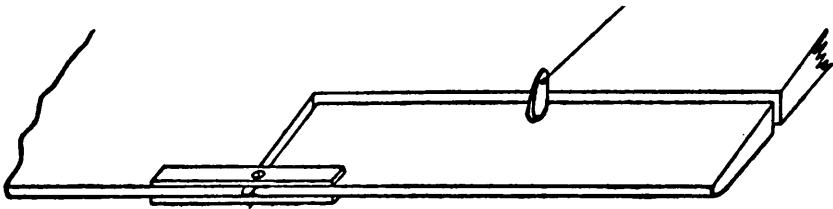

FIG. 17.—Aileron Clip.

final adjustment to be made. Cases have occurred where the clips have been left on for the first flight, but this should be carefully avoided.

All control cables should be only just tight. Flight is uncomfortable, and even dangerous, with loose cables, whereas, on the other hand, tight cables make controls stiff to work and prevent the pilot from obtaining the correct 'feel'.

See that all control surfaces are in their neutral positions when the control column is held central, and the rudder bar is in the central position, and make sure that the cables run properly over their pulleys, which latter should rotate freely.

Now check the controls for their correct functioning. *It is not sufficient to note that the various surfaces move with the control column, but make sure that the direction of movement is correct.* For instance, *when the stick is moved forwards the elevator should be depressed for diving, and vice versa.* In most cases the elevator cables have to be crossed to obtain this effect. Many serious crashes have occurred through incorrect elevator coupling.

Movement of the control stick to the left should raise the left (inside) aileron and depress the other. The ailerons are sometimes rigged so that both droop by an equal amount, and sometimes they are both set in a slightly raised position. The reason for giving droop is because the air load in flight tends to restore them to the normal position whereas the up-rigged position gives a differential effect during

turns, and thus overcomes, to some extent, stalling of the inside wing.

The explanation of this is simple, since it is obvious that the up-turned aileron will be further from the neutral position than the down-going aileron. However, *if the amount of offset is overdone there will be a loss of lift and also a loss, instead of a gain, of control*, and this is aggravated if the cables are somewhat slack.

The best position would appear to be either neutral, *i.e.* so that the aileron trailing edges are in line with the main plane trailing edges, or very slightly above, and it is important that both ailerons should be similarly set.

Lastly check the rudder movement. Forward movement of the foot should be accompanied by a sideways movement of the rudder to the same side.

The author has seen cases, with secondary machines, in which actuation of the rudder bar caused movements of the elevators, due, of course, to incorrect coupling up.

The instructor, or one competent member of the team, should carefully examine all joints and connections, starting with one wing,

including the aileron, then passing to the other, after which the fuselage and tail are checked, and finally the control system.

See that all wires and cables are locked, and all control surfaces properly secured and locked with safety pins. A hint worth remembering for all types of gliders is to insert all pins and bolts, wherever possible, with the heads forwards, or uppermost, so that in the event of a locking pin failing, or being omitted, the pin or bolt has some chance of remaining in position.

CHAPTER V

GLIDING—ELEMENTARY TRAINING

Having obtained a good general idea of the principles of flight, together with a knowledge of the action of the various control surfaces, the pupil is now ready for his first flights.

The Elementary Training Glider.—The initial flights are generally carried out on elementary training machines, as illustrated in Fig. 1. These gliders are not intended to be efficient, in fact they are purposely designed and built for cheapness, strength, ease of repair and low performance, and may be termed ‘knockabouts’. They are capable of soaring flight but are not really intended for such use.

With most training gliders the body consists of a girder fuselage for simplicity, but in some the girder stops short at the trailing edge, and is connected thence to the tail by means of four steel tubes, or outriggers.

It is not usual for the pilot to be enclosed, and there should be as little structure as possible directly in front of the pilot, so that in the event of a crash he may be thrown clear. On the other hand it is important that the skid should protrude well in front of the pilot, whilst the main plane, or pylon above, should be of sufficient height to prevent head injury in the event of overturning. In the illustrations of training gliders it will be noticed that the pilot is situated well back from a line joining the nose of the skid to the highest point of the structure at the main plane.

A good wide belt should be provided and should attach to some main structural member. It is claimed by some that the belt should not be too strong, so that in the event of a heavy crash the belt will break, thus taking the initial shock only and reducing the force of impact with the ground, whereas if the belt held, the pilot might suffer some internal injury.

If, however, the belt is made of webbing of six inches to one foot in width, then the force is spread evenly and the liability of damage is small. A good idea is to attach the belt to

the machine with elastic so as to minimize shock.

Another point worth mentioning concerns the base of the control column as this is a frequent cause of injury in bad landings. In some cases the seat is built forward to cover this and sometimes padding is provided.

Preliminaries.—The pupil is recommended to spend some minutes sitting in the glider to accustom himself to the 'feel' and to become familiar with the position of the machine in relation to the ground during landings. He should hold the control stick central and note that the ailerons and elevators are in their neutral positions.

A useful device, sometimes employed, consists of a ball and socket attachment which is firmly fixed to the ground and to the landing skid immediately below the centre of gravity, so that the glider is free to move in all directions but cannot leave the ground. The glider is set up on this, facing into the wind, and the pupil is made to balance the machine by the aid of the controls.

The action of the controls under these

conditions is slow, but the pupil learns the various movements for keeping on an even keel. If the glider is anchored in this way at the top of a hill the pupil gains better practice in the higher wind, and if he is taught to retain his balance by looking well ahead he will be getting used to the sensation of height.

This method should not be practised in very strong winds or damage to the glider may result.

Instead of the device described above, similar conditions can be obtained to some extent by the instructor holding one wing tip and moving it alternately up, down and sideways, the pupil correcting all movements with the controls.

In either case, the pupil should not make any actual flights until he has mastered the movements of control to the instructor's satisfaction.

Ground Slides.—It is not advisable for the pupil to rise from off the ground for the first one or two attempts, while he is getting used to the shock-cord method of launching. A calm day should be chosen when little or

no wind is present. A little wind is preferable to no wind for first flights as the speed of the glider over the ground is lower, by the velocity of the wind, than in an absolute calm; but elementary instruction should be limited to wind velocity below 12-15 miles per hour.

The wind speed is not really so important as the gustiness, but since the degree of gustiness generally increases, more or less, with the velocity, a fairly good indication of conditions can be obtained from the wind speed.

The worst winds are those with fluctuating velocity and direction and no elementary training should be attempted under such conditions.

The glider is faced into the wind on a level piece of ground, or sloping slightly in the direction of flight, and the pupil straps himself in. It is important that he should get used to strapping himself in and the instructor should make a point of checking this before each flight.

One member of the team is stationed at the tail for holding back, two members on each length of shock-cord, and the instructor may

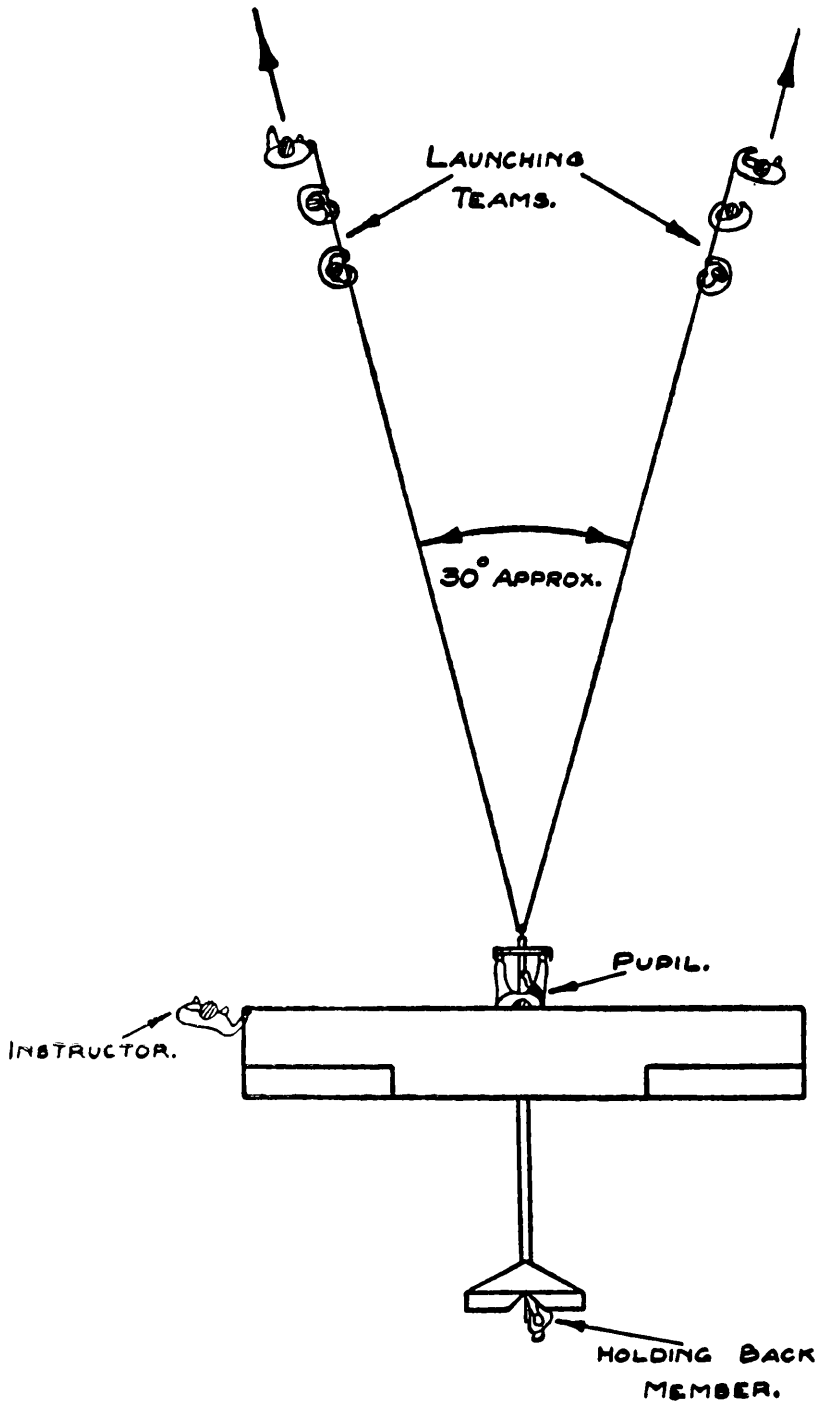

FIG. 18.—The Launch.

steady the wing tip. Teams of three may be used on the elastic, instead of two, as this makes the work easier, but in this case the instructor must carefully judge the release so as not to utilize the full force available.

The shock-cord is stretched out at an angle of roughly 30° , with the team as near to the ends as conveniently possible, and each end man should look ahead at some well marked object so that if the line of elastic were continued it would strike the object. This ensures that the direction of pull shall remain constant throughout the launch.

The teams *stand on the outside* of the shock-cord, to avoid being knocked down when it falls clear of the glider hook, and hold the cord at waist height. (See Fig. 18.)

When all is ready the instructor calls to the pupil, in a voice sufficiently loud to warn the start crews, "Ready!" This is followed by the command "Walk!", when each team commences to walk forward, each leader moving directly towards his picked mark.

The instructor should count the steps, and, after about six, will yell "Run!", and, almost

immediately after, "Release!", whereupon the tail crew let go and the glider moves forward while the starting crews continue to pull.

All commands should be loud, clear and short.

Under the conditions given, the glider will most likely have failed to leave the ground, to the disappointment of the occupant; but patience is necessary and will be well rewarded when the pupil first finds himself air-borne.

At least two such ground slides should be given, and unless the site is extremely small, the second attempt can start where the first finished.

First Flights.—The pupil is now told that he will leave the ground, but only for a few feet. He should be warned that if it feels to him that he is 40 or 50 feet high he should take no notice as actually it will only be 4 or 5 feet. He is told that the machine will take-off, fly, and land itself and that the less he moves the controls, the better will the flight be.

He should not attempt to use the rudder at this stage and may forget all about it. The

only movements he may make are sideways movements of the control column to retain lateral balance. The dangers of pulling the stick back, and the resultant stall, together with pushing forwards into a dive should be emphasized.

Both launching teams should number three and should be specially told to run hard after the word "Release!" They should also be warned to look back directly they feel the elastic fall clear of the glider and to fall flat immediately if the machine appears to be making for them. A warning shout by the instructor or any member of the team, should be acted upon at once.

If the pupil has done what he has been told he will find himself quite clear of the ground, sailing quietly through the air and, as the glider gently slips back to earth and comes to rest, he will feel particularly 'bucked' with life. But if, on the other hand, he has pulled or pushed the stick he will find himself in an unhappy predicament. The golden rule is to *bring the stick back to the central position, or slightly forward, and hold it there*, when the glider

will do its best to extricate him from his unhappy position. If all is well, and he has time to think, he should gently ease the stick back to the normal position just prior to touching the ground.

The instructor cannot stress too much *the need for gentle movements of the controls*. It should never be necessary to make violent movements during elementary training, unless it is to bring the stick back into the neutral position, after putting the machine in a stalling condition. The pupil should remain seated after all flights until others arrive to hold the wing-tips, otherwise the glider is liable to blow over. This point cannot be overstressed and the pupil should be warned not to jump out of the machine in the excitement resulting from the first flight.

Pilot's Weight.—Training gliders are designed for pilots weighing about 160 lb which means that if pupils considerably heavier, or lighter, are to make flights some weight adjustment should be made, or the machine will be ‘nose heavy’, or ‘tail heavy’, accordingly. Often in such cases the poor pupil does what he has

been told, without moving the control column, and, to the amazement of both pupil and instructor, the glider incredibly commences to climb or dive after the take-off.

This can be avoided by attaching a small balance weight in some suitable position. In most training type gliders the pilot's weight acts at a point about 2 ft 6 in in front of the centre of pressure.

Now suppose a 14 stone pilot is to fly, then the excess weight is roughly 30 lb, situated $2\frac{1}{2}$ feet in front of the C.P., or 75 pounds-feet (by multiplication), and this can be balanced by a small weight attached to the fuselage in the neighbourhood of the tail. The distance to the weight attachment point should be measured from a point $\frac{1}{3}$ rd chord back from the leading-edge, and we will assume it to be 10 feet.

Thus the weight to be added is $75/10$ or 7.5 lb only. It may be argued that a heavy pilot does not need to be still further handicapped by extra weight, but this is not the case, although the instructor should always take the pilot's weight into consideration when

gauging the strength of the pull-off. Similarly a nine stone pilot will need an added weight of, say 30 lb placed in the seat or half this amount fixed at the extreme front of the skid.

Lateral Control.—These short flights should be continued, but the length of flight can be gradually extended by launching from higher points over ground with a slope not exceeding the gliding angle of the glider, say 1 in 10, and of less amount for preference.

The pupil should concentrate on keeping lateral balance and the instructor should note that the stick is always moved to one side immediately the wing-tip on the opposite side tends to fall. Lateral balance on such small flights, and with so little speed, is not always easy, so that the instructor must be content by satisfying himself that the pupil knows how and when to use the ailerons. Also the pupil should not be disheartened if the ailerons seem unwilling to act as they should, since this state of affairs will change as soon as longer flights are made.

Larger control surfaces on training machines would help to overcome this difficulty but

they would also invest in the pupil greater powers of destruction.

Use of Rudder.—After, perhaps, a dozen flights, the rudder should be brought into play. The pupil will have been told to pick a point well ahead of him and to watch this mark throughout the flight. Now he should be told that *if the mark tends to move away to the left, or right, meaning that in reality the glider is moving away in the opposite direction, he must correct this by pushing forward the foot nearest the mark, that is in the direction in which he wishes to go.*

Beginners have great difficulty in mastering the rudder control and almost invariably do the reverse to what is required. It has always been stated that the actuation of a rudder of an aeroplane is ‘instinctive’, and since pupils of powered craft have several hours of dual instruction before flying solo, during which time they get used to the method of turning, no one has troubled much whether this is correct or not. But instruction with gliders has definitely shown that this is not the case and a great deal of confusion exists. If the instructor watches his pupils carefully during

the early part of their training he will notice that the rudder is often first turned the wrong way.

The glider is guided (so far as the rudder is concerned) in exactly the same way as a boat, this being opposite to the movements of the handlebars of a bicycle. The difference is due to the position of the part causing the turn, the rudders of boats and flying machines being at the back, whilst the guiding wheel of a bicycle is in front.

The importance of keeping the glider flying straight into wind, especially during the landing, should be impressed on the pupil. As he approaches the ground he should watch the surface over which the glider is about to pass, that is to say he should keep looking a few paces in front of the machine.

If the glider is not moving dead into wind, but drifts sideways with it to some extent, the ground will appear to be moving sideways under the skid and this must be stopped by pushing forward the rudder bar on the side towards which the ground appears to be moving, when it will be found that the ground

comes to rest. *The rule is to turn so as to move with the ground.*

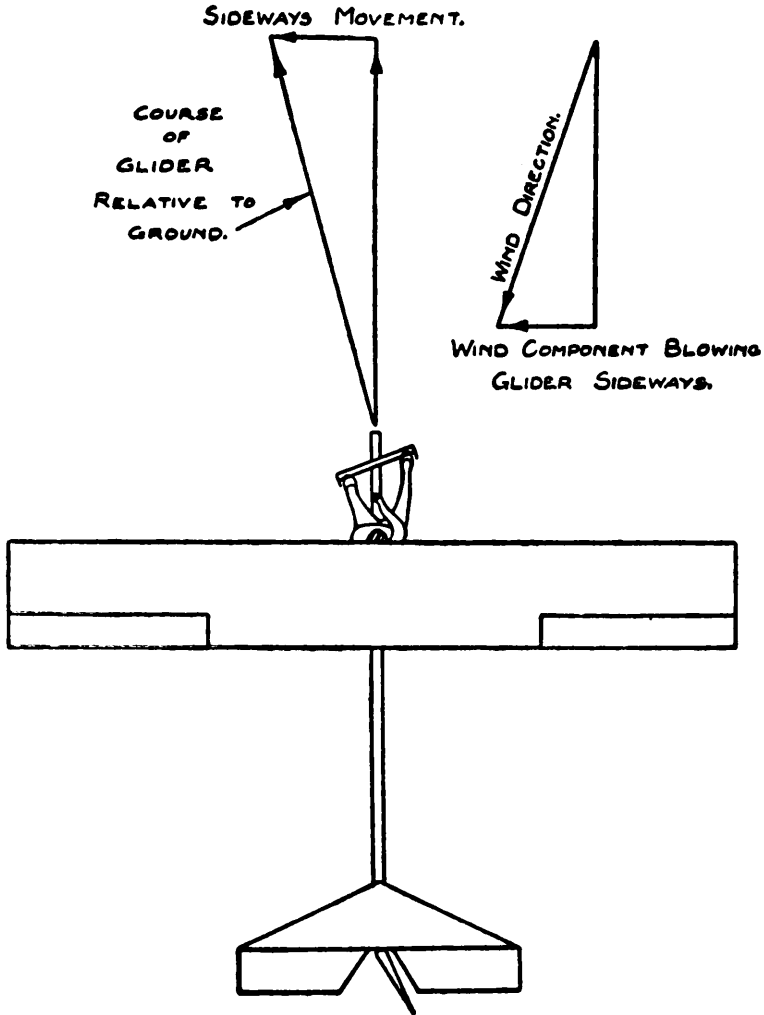

FIG. 19.—Correction of Drift.

Fig. 19 shows a glider flying in a wind which is blowing at an angle to the direction in which

the machine is pointing and thus has a component velocity, which moves the machine to the left relative to the ground. It is clearly seen that a partial turn to the right will bring the machine facing into the wind, when all sideways motions will cease.

Position of Hands.—During the early flights most pupils seem very undecided where to place their free hand, and it is a common sight to see the left hand grasp the seat bearer just as the launch takes place. This is disconcerting, besides which it happens at a time when the pupil needs his whole attention for directing the flight.

To overcome this a short strap is sometimes suspended just over the left shoulder and this the pupil holds with his left hand; his right being, of course, on the control stick. This has the added effect of making the pilot sit upright. A crouching attitude should be avoided.

If both hands are placed on the column the tendency to pull the stick slightly to the right is overcome. Some instructors hold that this encourages heavy-handedness, although there is little to support this view.

Unless the left hand is on the control stick, or is holding the strap above the shoulder, the pupil should grasp the seat, or its support, before the flight commences.

It is perhaps too early to expect the pupil to hold the stick lightly and not to press hard on the rudder bar, but the instructor should make a point of mentioning this often, especially when the first soaring flights are made.

The correct time for practising turns is after the "A" certificate stage, and this will receive attention later, but if the gliding site is such that the pupils have to fly from a considerable height, or over rocky, or uneven, ground, in order to qualify for the first certificate, then some instruction in turning should precede the attempt.

Duration of Flights.—The first flights will last somewhere about 5 seconds, and the time will increase to say, 8, 12, 20 and 30 seconds, about 6 to 8 flights being made at each stage, making a total number of 30 or 40, and representing 7 or 8 minutes' flying time.

Weather permitting, each stage requires one day of instruction except for the 20–30 second

flights which may take longer. With fair weather and a good training site the average pupil should be able to obtain the first certificate in a week of continuous training.

The "A" Certificate.—The pupil having carried out 30 to 40 flights to the satisfaction of his instructor, the time has arrived when he may try for the "A" certificate. This requires a flight in a straight line of at least 30 seconds' duration.

A moderately calm day will be chosen and the glider set in a position from which the instructor knows a half minute flight can be reasonably obtained. The pupil will be warned against any faults that have made themselves apparent during earlier flights, such as too great a forward speed caused by a slightly forward position of the stick; a tendency to stall; or turning to one side.

The instructor might also consider that the launching teams can safely be increased to four on each rope, but even so the launch should not be too forceful.

The pupil knows that he has to make a flight of longer duration than hitherto, which can only be done by a steady, gentle glide with very

little control movement. It is really a test to see whether the pilot is capable of letting the machine glide on its natural course without subjecting it to unnecessary movements. The duration will not be lengthened by zooming, *i.e.* climbing steeply immediately the release is given, as this causes the elastic to drop off before it has given up its stored energy to the

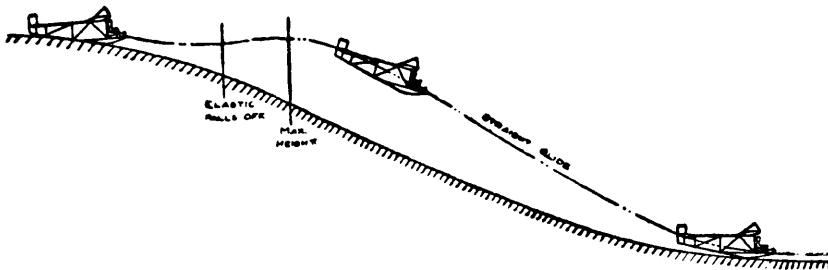

FIG. 20.—First Flights.

glider. The launching crew will get the benefit of this and will not be grateful either!

The start should be carried out in such a way that the full force of the launch is made use of, which is done by climbing only slightly until the elastic falls clear. Then a moderate climb can be made until the air speed is reduced to normal when the stick should be moved forward to just slightly in front of the central position, and held there. (See Fig. 20.)

If the speed is too high all the wires will buzz, and the airflow over the wing, and other parts, will be distinctly heard. The stick should be eased gently back. But if on the other hand a complete silence seems to be setting in, move the stick well forward before the dreaded stall takes place. As the speed increases so the control column can be eased back again, but not so far as previously.

Retain the lateral balance with the aid of the ailerons, and keep the glider directed towards the chosen mark by means of the rudder.

The result will then be a cheer from the hill-top announcing your 35 to 40 seconds flight.

CHAPTER VI

GLIDING—ADVANCED TRAINING

One of the features of the teaching of flying by means of motorless craft is that there are no gaps comparable, say, with the first solo flight on power machines ; the whole training forming a smooth flow of progressive work. When a person who has never flown watches a sailplane pilot, it perhaps appears that he is endowed with such uncanny skill that the on-looker can never hope to emulate his achievements. But this is not so. The truth is that there are very few indeed who cannot learn to soar if they apply themselves with a moderate amount of determination, and, in fact, so continuous is the course of training that anybody of normal intelligence, with full use of his faculties, can hardly help becoming proficient.

Much depends on the instructor and his ability to make best use of weather conditions,

but pupils must abide by his decisions and not attempt to force the training forward when the instructor considers that the wind is too high, too gusty, or in an unfavourable direction.

Gliding flights are gradually extended until the top of a hill, suitable for soaring, is reached as a launching point. After this the pupil is taught to fly parallel with the hill so as to prolong the flight by the aid of any slight up-currents that are caused by gentle winds blowing towards the hill, and still later he learns to turn back on the track so as to follow the hillside still longer. This is the work that is intended to be covered by the " B " certificate.

A more efficient machine is then provided which enables the pilot to repeat the earlier flights, but with the difference that the decrease in sinking speed allows the course to be followed without loss of height. And so soaring flight is achieved.

Now we must resume our training.

Improved Performance Glider.—For the more advanced part of gliding training, a machine with a slightly better performance is sometimes used. The primary trainer can be easily

modified for this purpose by the addition of a nacelle, that is by building a fairing round the pilot.

In some cases the fairing is built behind the pilot only, but the better method is to construct also a detachable front fairing so that it can be fastened on for flights where greater duration is required.

Such a machine is suitable for soaring flight and thus can be made to serve two purposes.

The use of a glider, improved in this way, increases the repair bill in the event of crashes, and for this reason it is preferable to retain the elementary machine until after the "B" certificate stage. However, the addition of a nacelle, in some cases, permits flights of the required duration to be made which would otherwise be impossible, and, therefore, clubs where training sites are not suitable for flights of one minute should adopt this method.

If the qualifying flight for the "A" certificate did not commence from the top of the hill, it is likely that the next few flights will be devoted to this achievement.

Flights of at least 45 seconds' duration will

be aimed at, together with the most important part of training, that of turning ; in fact it is not safe to continue further without successfully mastering the turn.

Turning.—The pupil will have learnt to use his rudder for keeping the glider on a straight course and also his ailerons for retaining lateral balance. He must now learn to use both controls simultaneously so that the operation of the one is seldom done without the accompanying actuation of the other.

Sailplanes, and aeroplanes, have been constructed, in which these two controls are interconnected, to prevent the use of one without the other, but these have not been entirely successful.

Nevertheless the pilot must get into the habit of working the rudder and ailerons harmoniously together.

If a glider is flying on a normal course and rudder is applied, say by swinging the rudder to the left, then the tail will be forced to the right so that the direction in which the glider points will be changed to that required ; but the momentum in the original direction has not

been overcome and the machine continues, in a side-slipping fashion, on its original course until the energy has been destroyed by the friction of the air with the fuselage side and other parts of the machine. The result of this may be a spin and should be avoided.

Again suppose the ailerons alone are actuated so as to place the glider in a banked position. If no rudder is used, a sideslip will commence towards the down-tilted wing-tip. The effect, then, on the glider is similar to that of a gust of wind blowing from one side whereupon the directional stability, referred to in Chapter III, will cause the nose to turn into the gust, or side wind. In other words the nose will go down and a dive will result.

Remember then, that too much rudder means a sideslip outwards and too little rudder, or overbanking, results in sideslipping inwards. In both cases the rush of air will be felt on the side of the pilot's face and this acts as a good guide.

The pilot should know that *pressure on the side of the face during a turn means overbank, or too little rudder, if on the side towards the down*

turned wing-tip, and underbank, or too much rudder, if on the outside.

Quite gentle turns should be practised first, by applying a little rudder and bank together. Practice turning only when the flight is sufficiently long to prevent contact with the ground, when unprepared, and do not commence a turn until the initial force of the launch has passed and the machine has settled down to a steady glide.

It is difficult to say how far the control column and rudder bar should be moved, especially as the exact amount varies with different types of gliders ; but the pupil will quickly know whether the turn is correctly executed or not and his instructor will give the necessary advice.

After making a gentle turn through an angle of say, 45° to the left, move the rudder bar and control stick similar amounts in the opposite direction and so complete a long ' S '. Then centralize again and glide in to land.

When the instructor is satisfied with the gentle turns it is advisable to do sharper turns, that is with greater bank. The wings may make an angle of 30° , and later 45° with the

horizontal. Harsher use of the rudder will be required, in fact with most training machines the full movement will be necessary.

A new factor now begins to show itself. The wing on the outside of a turn moves at a greater speed than the inner wing and in doing so the lift force is increased (see page 33) and this tends to still further increase the bank ; an undesirable feature.

As this is happening the pupil is aware of what is going on but he knows also that he has not moved the controls further than was necessary, and as there is an accompanying feeling of security he may be inclined to leave matters as they are. The inevitable result is a sideslip followed by a dive, or even spinning, and to prevent this the control column should be moved back towards the neutral position.

The correct method of turning, then, is to apply rudder and bank to the required extent to start the turn after which the stick is moved back to, or near, the central position when the glider will continue in an even turn. To end the turn bring the rudder back to central and move the stick over in the opposite

direction until the machine is on an even keel, when the stick also is brought back to central.

During a turn there is a loss of lift in the vertical direction and an increase in the minimum, or stalling, speed. This should be compensated for by depressing the nose and thus slightly increasing speed.

For a 45° banked turn the loss of vertical lift is less than one-third of the weight, which would require an initial speed of 30 m.p.h. to be increased by about 6 m.p.h.

The increased speed should be gained just before starting the turn and *not during the turn.*

By the time the pupil has mastered these turns he will have made his two 45 second flights which constitute the first part of the qualifying tests for certificate "B".

Obstacles.—So far all flights have been directed by the instructor, but it is now time for the pupil to choose his course and landing spot. The pilot should have his flight mapped out in his mind before he is launched, making necessary modifications as they become apparent, and thinking ahead of the effect of such changes on the remainder of the flight.

A sudden gust of wind lifts the glider by an extra 20 or 30 feet, which will mean an overshooting of the intended landing point, unless an extra turn is made to lengthen the glide.

Obstacles such as haystacks, hedges, bushes, banks or ruts, will often appear in the line of flight as the glider is nearing the ground. Avoid them by turning to one side; not too suddenly, or the bank position will cause a decrease in lift and perhaps stall the machine into the obstacle. Increase the speed slightly as a precautionary measure, then turn and return to an even keel as soon as the danger is passed.

In some exceptional cases a steep turn is unavoidable which may mean actually pivoting one wing-tip on the ground so that a 180° turn is made followed by a down-wind landing. The machine might suffer some damage, but it is better than colliding with a fence, and the chances of getting off scot free are not small.

Never hold the nose up in an attempt to just clear some obstacle. Pupils are sometimes seen doing this and the more they hold back the

stick the slower drops the speed until at last the glider pancakes heavily. Even so the damage is generally remarkably small.

The crash can usually be avoided by *diving at the obstacle*, pulling up the nose just as the obstruction is reached and so gliding over the top. The speed will quickly fall, and hence a dive should be recommenced at once just prior to flattening out.

Whenever possible turn to one side before allowing yourself to get into this unhappy position.

Side-Wind and Down-Wind Landings.—Some instructors believe in getting their pupils used to landings other than normal up-wind, so that when such landings have to be made the pupil does not find himself in difficulty.

These should be practised on ground having a slight slope only, when the wind velocity is small, and can thus be made to fill in time when no hill site is available for the existing wind.

For down-wind landings the glider is launched into wind, after which it is put into a gentle turn until it faces back in the direction opposite to the original, levelled off, and

landed. The only difference between up-wind and down-wind landings is that the wind speed is added to that of the glider, *instead of being subtracted*, to give the ground speed.

Thus a glider with a landing speed of 25 m.p.h. lands at 5 m.p.h. when facing a 20 m.p.h. wind, but touches at 45 m.p.h. down-wind. In the lighter winds used for training, the difference is not nearly so pronounced, the up-wind and down-wind landing speeds in a 5 m.p.h. wind being 20 and 30 m.p.h. respectively.

This means that the pilot finds himself flying over the ground at what seems an excessive speed and yet the wires do not hum, nor is the 'swish' of air over the wings audible.

The high speed tends to make the pilot pull on the control column, whilst the silence warns him of the approaching stall. *He should be guided by his ears and not by his eyes*, ignoring the high ground speed, paying attention only to the air speed sense he has been developing, and all will be well.

The speed at which contact is made is higher, and the run along the ground longer, and, of equal importance, *any manœuvre necessary for*

averting an obstruction must be commenced sooner to allow for the more rapid approach. This is the real danger of all down-wind flight.

After some down-wind landings have been carried out in a light wind, one or two might be made in a high wind although they should never be attempted if avoidable in really high winds.

Side-wind landings, also, should only be made, when the wind speed is slight. If they are done with the machine in the normal position, with the main plane horizontal, the skid will be forced sideways over the ground, by the wind, so that some damage is likely to result in any but low winds. This can be avoided by banking the glider into wind, *i.e.* the wing tip facing the wind is lowered, and at the same time rudder is applied on the opposite side (often called top rudder) with the result that the glider slips towards the lower wing, and this compensates for the side velocity due to the wind.

The " B " Gliding Certificate.—The requirements for the second certificate are :—

Two flights of at least 45 seconds' duration, and

One flight of at least one minute duration, in which a complete ' S ' turn is made, followed by a normal landing.

The ' S ' turn is required for showing that the pupil has properly mastered turns in both directions, accompanied by no undue loss of height, and, at the same time, such a flight is one of the preliminaries of soaring.

The final flight of one minute can often be made by starting from the same point as was used for the 30 seconds and the 45 seconds flights. The wind should be by no means strong, but it may be higher than obtained in the case of the " A " certificate flight, the extra time being achieved by staying longer in the up-wind area.

The launch should be normal, facing directly into wind and no attempt to turn should be made until after the first few seconds. This precaution is taken in order that the main up-wind area may be passed through, and also to avoid turning too close to the hill. If the turn is commenced too soon the glider may be lifted high above the starting point and the pilot may lose his head when he finds he is

so high up, and in an unusual position, *i.e.* flying along, and above, the ridge.

Having turned parallel to the hill (note that the glider should be pointing slightly away from the hill to prevent drifting back on to the hill face), the flight should be continued in the

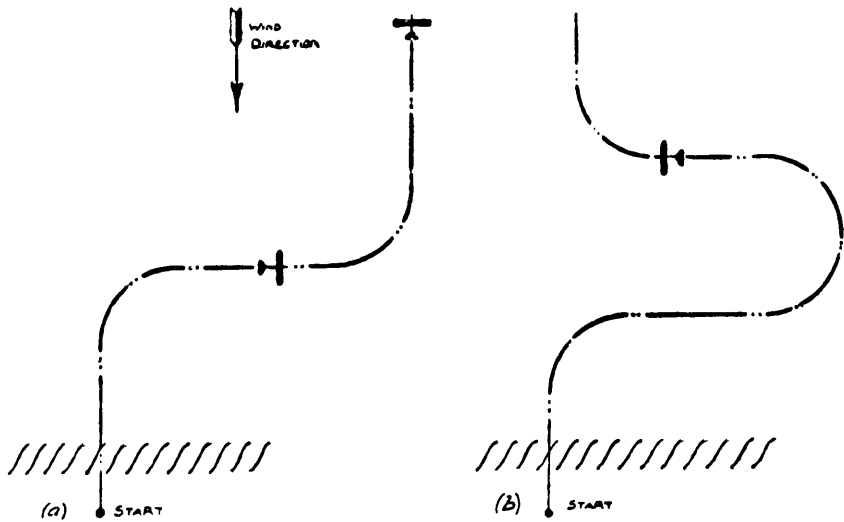

FIG. 21.—The "B" Certificate Flight.

same direction until about 50 feet from the ground, when a turn into wind, in the direction opposite to the first turn, should be made, followed by the landing (see Fig. 21*a*).

An alternative flight may be made by prolonging the second turn (which in this case

should be started earlier) until the pilot faces back along the hillside (Fig. 21*b*) and then making a third turn into wind for the landing. This is a better flight and brings the machine back closer to the point of departure.

Training by Dual Instruction.—A good deal of controversy has existed concerning the use of training by means of two-seater machines. Undoubtedly this method has considerable advantages, but it also suffers from certain defects, which to some extent detract from its value.

When dual instruction is carried out by the aid of auto-towing or winch launching, most of the disadvantages disappear, but this applies also to the ordinary hand-launched free flight, and of course the initial expense involved is greater.

In dual instruction the instructor generally takes the back seat, with the pupil in front, so that the instructor can see exactly what his pupil is doing. The absence of noise enables conversation to be carried on easily, and the instructor is able to correct any faults on the pupil's part.

The pupil gains a certain confidence because he knows that when, after several flights, he is allowed to take complete control the instructor must be satisfied that he is quite safe, whereas in the absence of dual training an instructor might send his pupils off from a considerable height, whether they are proficient or not, without knowing what their reactions to such a height may be.

The chief disadvantages of this method of instruction are that one of the claims of gliding, that the pupils is in sole charge on all flights, becomes lost ; the instructor also is harder worked ; and the pupil does not pilot the machine during the whole time it is in the air.

There are three ways of giving dual instruction, in all of which the merits, and demerits, as set out above, do not apply to the same extent. The methods are :—

- (a) Dual instruction by gliding
- (b) Dual instruction by soaring
- (c) Dual instruction by auto-towing, or by winch-launching.

(a) In the first the instruction is similar to that described for elementary training with

machines of the 'Zogling' type. The extra weight of the two-seater, together with the short time in the air, make the method of little use, except perhaps when used in conjunction with solo practice.

(b) Soaring instruction can be given with the aid of a dual controlled machine, but even here it is of little use unless the pupil has made a number of landings on single seater machines. It is of no use being able to soar, if the pilot cannot be relied upon to make safe landings.

Also the pupil may only take over control for short spells, or the flight may end prematurely through loss of height, and it might not be a happy ending either!

This indicates that the correct place for dual instruction is after the "B" certificate stage, as an introduction to soaring.

(c) Where a suitable site and touring car or winch are available a very useful method of training is provided. But instruction by this method can be given with single-seaters as well as with two-seaters. In either case the time in the air is the same, but whereas, with single-seaters, the pupil holds the controls

for a longer period, with a dual machine the pupil gets the benefit of immediate correction by the instructor.

In summing up it may be said that if a dual control machine is available, together with housing accommodation for the extra machine, then it is a definite aid to instruction, but it need not be looked upon as an essential part of the equipment. This is meant to apply chiefly to small clubs or groups, but for school work the potentialities of training by means of winch launching, with two-seater machines, are very considerable, especially where rapid results are desirable.

CHAPTER VII

SOARING

The Soaring Machine.—Secondary machines used for soaring practice do not differ greatly from elementary gliders, the chief difference being the addition of a covered-in fuselage, or a nacelle, in order to reduce the air resistance due to the pilot's body.

The drag of a typical fuselage for a secondary glider is roughly one-third that of an elementary machine with the pilot exposed, and since this saving represents nearly one-third of the total resistance of the elementary glider, it is easily seen that the gliding angle must be improved by approximately 50 per cent. In other words, by fitting a streamline fuselage or nacelle to an elementary glider, the gliding angle is changed from, say, 1 in 8 to, perhaps, 1 in 12.

The wing-loading of intermediate machines is between 2 and 3 lbs per square foot of main

plane surface, whilst the span varies from 30 to 40 feet.

Types of Intermediate Gliders.—The 'Pruffling' was one of the first standard intermediate types, and is of normal 2-spar construction with centre-section and wing lift-struts. It is quite a pleasant machine to fly, but needs a fairly high wind, has a rather fast forward speed, and is very sensitive in elevator control. On account of these qualities it has lost popularity as a training machine.

The 'Falcon', which was designed by the R.R.G. to supersede the 'Pruffling', has swept-back wings, in which the incidence decreases towards the tips, known as wash-out, thus giving stability and power of control. The wing is supported on short centre-section struts, and a pair of 'V' struts. It soars in winds of moderate intensity and is light on controls, but not over sensitive. Its one unfavourable feature is the limited field of vision due to the pilot's seat being placed immediately below the wing, which constitutes a source of danger when more than one aircraft is in the air at the time.



THE "GRUNAN BABY II."

The 'Hols der Teufel' is essentially a light wind soarer, having a large wing area, large span and light wing-loading. The tail unit is supported by outriggers, in a similar fashion to the elementary glider, whilst a nacelle is provided for housing the pilot and controls.

The wings are of two-spar construction with rather long supporting lift-struts. The gliding angle is normal for this type, but both forward speed and sinking speed are low, the latter being little higher than that as recognized for machines of the sailplane category.

The 'Kassel 20', is almost a high efficiency machine, or it may be regarded as intermediate between the secondary and advanced types. It is a light-wind soaring type, not very dissimilar to the 'Hols der Teufel', apart from the substitution of a fuselage in place of the nacelle and outriggers. The outstanding quality about this machine is its ease and lightness of control, besides which the controls seem to stay steady in any position. The construction is, however, rather light, which renders the machine somewhat unsuitable for club use.

The 'Grunan Baby II'. This machine has

a single-sparred wing attached to a 'neck' on the fuselage, and supported by single lift struts on either side, the torsion being resisted by a plywood nose. It was designed for cheapness, ease of construction and repair, and for controllability.

The fuselage is of hexagonal section, plywood covered, to which is attached a fixed tail plane, and a small vertical fin.

The span is just over 40 feet and gives an aspect ratio of 12.8.

The general robustness of construction, and good manœuvring and stable qualities, make this an ideal club training soarer whilst performance flights are also possible.

See table for particulars of soaring machines.

PARTICULARS OF INTERMEDIATE GLIDERS

	TYPE				
	<i>Falcon</i>	<i>Hols der Teufel</i>	<i>Pruf- ling</i>	<i>Kassel 20</i>	<i>Grunau Baby II</i>
Total Weight, lbs . . .	415	360	381	375	396
Wing Area, sq ft . . .	166	220	164	166	153
Wing Loading, lbs/sq ft . .	2.5	1.64	2.32	2.26	2.59
Span, ft . . .	42	41.8	32.75	46.2	44.3
Aspect Ratio .	10.6	7.95	6.5	12.84	12.8
Sinking Speed .	Medium	Low	High	Low	Medium

Note.—The Total Weight given in the above table allows 150 lbs for pilot's weight.

The easiest types to fly are the lightly loaded, slow-moving, machines, although the faster machines teach quicker thinking, and thus produce greater skill. A safe plan is to give soaring instruction on slow machines first, finishing off on faster types before passing on to sailplanes.

Soaring Flight.—Before making a real attempt to soar, it is very advisable to make a few practice flights in the soaring machine so as to gain familiarity with its flying qualities and the finer gliding angle. The pupil will notice the considerable improvement in the power of control, due largely to the relatively undisturbed airflow in which the tail units work, in comparison with the open primary machine.

One or two launches on level, or slightly sloping ground, should be made with teams of four on the elastic, after which some flights from a height of, say 50, 100 and 150 feet, can follow. The first objective of these flights is to become accustomed to the feel of the machine, whilst the second is to find the natural gliding angle

and to get used to holding the glider in this position.

Thirdly, on the longer flights, turns should receive full attention. Remember that on your ability to make proper turns your successful soaring will depend. *The turn constitutes half the battle of soaring flight, the other half consists in flying at the correct speed, and hence, gliding angle.*

The next attempts are made from the hill-top, in little or no wind for preference, but may also be carried out in a light soaring wind, although, in this case, the pupil should be told not to turn until the main up-wind area has been passed through. The pupil may think this is being unnecessarily cautious, but provided that soaring is possible he should be appeased by the promise that he will be allowed to soar before the day is out.

A machine in the hangar is worth two in the bush!

It is well if *the first attempt for the "C" certificate is made on a day when the wind is just too low for soaring flight to be possible.* The reason for this is that the pupil is given full instruction where and how to fly as though

soaring were possible of achievement and, if he is up to the required standard, he will manage to perform the first lap, that is along the ridge and back. He will thus have learnt exactly what he is expected to do and will soar easily on the next attempt.

The wind velocity must not be very great for the first few soaring flights, or the pupil will be lifted to such a height that he may tend to feel a loss of contact with the hill, with the result that he may not know just where he should fly.

The instructor should pick out a length of even hillside of, say, $\frac{1}{4}$ to $\frac{1}{2}$ mile in length, where the gradient is not too precipitous and which is free from eddy-forming obstacles, choosing one end of the stretch as the launching point. It is a good plan to station a member at each end of the course, or flags may be inserted, to mark the turning points.

The pupil will be instructed to *turn directly after the launch*, so as to fly parallel with the hill-face. Here a warning against overbanking may well be given as the pilot will find the up-current tends to increase and prolong the

turn with the probable result that he finds himself charging straight into the hillside.

As soon as the launching rope falls clear, the glider should be climbed reasonably steeply, so as to obtain the maximum height from the launch. If the launching position is well chosen, the climb will take place where the up-current is best, and it is here that the first turn should be made.

The first turn may be made fairly steeply, more so than for the succeeding turns, to ensure remaining in the up-current belt.

A height of 30 to 50 feet will have been gained in the launch, but some of this will probably be lost during the next few seconds while the pilot is settling down to the correct gliding speed. If he is cautious he will tend to err on the high side, but if he is over anxious to soar he may let the speed become so low that he finds himself rapidly sinking in a condition very close to the stall.

Remember that soaring is gliding. The only difference is that you are gliding down through air that is ascending ; therefore you should hold the machine in the normal gliding position that

you have become accustomed to in your earlier flights.

After the turn has been made, and provided that the machine is still at least about 20 feet above the crest of the hill, turn slightly towards the crest to the position marked 'A' in Fig. 22, and retain this position relative to the hill until a turn is to be made. Never pass over the crest, shown by the line *x x*, unless at least 40 or 50 feet above the surface, and even this should be done only to assist the turn.

Turning.—When it is decided to turn, pass over the crest by a distance of about 50 feet, as at 'B' and then turn in the usual way, without using too much bank. The turn will be continued until the position 'C' has been reached when flattening out should be commenced, the final position being at 'A' again, but, of course, facing in the opposite direction.

This procedure is repeated at the opposite end.

As explained in the previous chapter, there is a loss of lift during a turn due to the

inclination of the wings to the horizontal, and therefore a slight increase in speed is necessary. *This slight increase in speed should be gained before, not during the turn.*

The turn is started by applying rudder and bank simultaneously: full rudder may be used and just sufficient bank to enable the turn to be executed. If too little bank is given the machine appears to have no desire to change its direction, in which case a little more aileron must be applied.

There seems to be a critical angle for the main planes, which varies with speed, below which movement about the vertical, or yawing axis is very sluggish indeed.

Having started the turn, keep the amount of bank constant by slightly easing the control column towards the higher wing; the speed being kept constant throughout.

As position 'C' is reached (Fig. 22), or just a little earlier, the bank is slowly taken off. The decrease in speed to normal may be achieved by easing the stick backwards when it will be found that *the elevators greatly assist the turn.*

The reason for this is that the lateral axis has become inclined to the horizontal, and hence rotation about this axis causes sideways

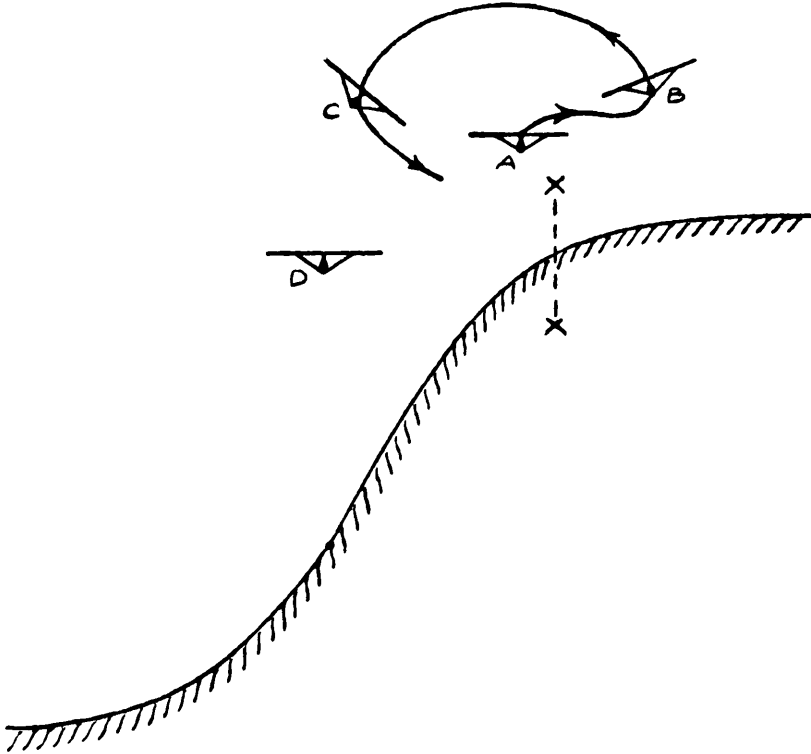

FIG. 22.—Turning in Soaring Flight.

as well as vertical movement. This can be better understood by looking at Fig. 9.

If, for any reason, so much height is lost that the glider descends below the hill crest, it is inadvisable to hug the face too closely,

or a sudden drop, due to an eddy, may have disastrous results. Also be ready at all times to turn out from the hill in the event of an emergency. On the other hand, if the pilot strays far from the hillside, the up-current will be entirely lost, when descent will be inevitable. Position 'D', shown in Fig. 22, is about right for this case and it is often possible by careful pilotage to regain the crest.

Don't be over-zealous. It is much better to land and try again than to try conclusions with the hillside.

Hands and Feet.—As soon as you are safely in the air, think again about your hands. Are you grasping the controls too tightly? Are your feet pushing hard against the rudder bar or pedals? If so, *relax and make yourself comfortable*, when you will find the strain of flying almost disappears.

Carefully avoid 'pump handling', by which is meant too vigorous movement of the control column so that movement in the opposite direction becomes immediately necessary. Hold the controls lightly but still, and when movement is required ease

the stick in the desired direction free from any jerking.

The 'C' Soaring Certificate.—The soaring certificate is awarded for a flight of at least five minutes above the starting point, completed with a normal landing.

A flight of longer duration, during which the pilot remains for one period of five consecutive minutes above the point of departure, is often allowed to qualify for the certificate.

The pilot is advised by the instructor to fly forwards and backwards along the chosen stretch of the ridge, taking care to keep in the best up-wind area and making careful turns at each end.

It is a good plan for the instructor to stand midway between the end marks where he can give signals with a white pocket handkerchief. If he wishes the pilot to keep further away from the hill he stretches his arm out in that direction, and similarly he points towards the hill when the pupil gets too far out. Other advice can be given by shouting, but the pupil is generally too fully occupied with the controls to take much notice.

Generally speaking the pupil should be signalled to land after about 8 or 10 minutes. This prevents him from becoming tired or over-confident, and the instructor will take the opportunity of pointing out his faults.

Landing.—The first few soaring flights should be concluded with landings at the bottom of the hill; not that there are any great difficulties in the operation of landing on the hilltop, but because it is better to keep the early flights as free from complication as possible, and this can be helped by stipulating that the landing should be made on ground and in air conditions known to the pupil.

The landing, then, should be made in exactly the same manner as in all previous landings, the only difference being the extra height to be lost on the approach.

Having decided to land, the tendency with most inexperienced pilots is to get down by the quickest possible manner. Down goes the nose with a consequent rapid increase both in speed and in the sensitiveness of the controls.

Unused to the excessive speed, which may

easily become twice the normal in the course of a few seconds, and the fierceness of the controls, the pilot usually descends in a series of swoops, sideslips, and frightening dives.

It is true that the loss of height is rapid, often surprisingly so ; but there has been little time for judgment and, when at last he flattens out, the pilot finds the speed is still uncomfortably high, and possibly he is faced with obstacles, hedges, trees or hangars, which are far too near for his liking.

This 'cut and dash' style of finish is decidedly bad and is, besides, the most difficult form of landing. Instead the descent should be allowed to take some minutes.

First fly a short distance away from the hills—even this may be done gradually by slowly increasing the distance separating you from the hillside—and then continue flying at the same normal speed, parallel to the hill, as though attempting to soar too far out (see Fig. 23). You probably did this anyway on your first soaring attempt and finished with a well judged landing !

Being clear of the main up-winds, height

will be gradually lost and while this is taking place a gradual return movement towards the hill may be made, as illustrated in the Figure. If it is found that height is being regained, the return to the hill has been made too soon and should be corrected by flying further out

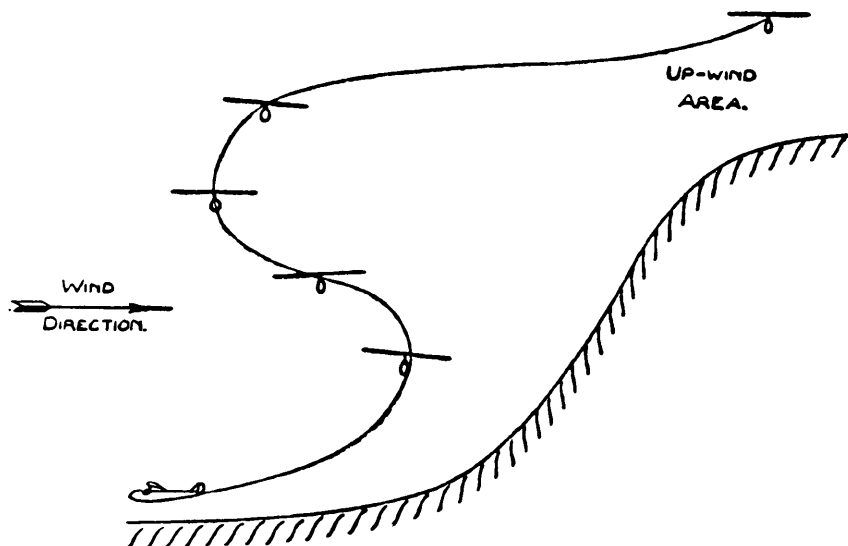

FIG. 23.—Landing after Soaring Flight.

again. Also there is no need to hug the hillside too closely, as sudden drops, due to eddies, may be encountered.

Watch your chosen landing spot the whole time, never turning your back on it, and, when you find that there is just sufficient

height for a nice glide in, turn into wind and land.

Later on you will learn other methods of slipping off height, but at this stage your flying should be kept as straight-forward as possible.

Soaring in Strong Winds.—It has already been mentioned that the first soaring flights should be made in winds of reasonably low velocity, but, as soon as these have been successfully accomplished, flying should be carried out in winds of increasing strength.

The chief differences will be found in the launch, and on landing, and in the much greater height that will be attained.

When the wind is high there is no need for so vigorous a launch and even so the pilot will notice the great upward acceleration, but he should not let this upset him. The greater height he will soon get accustomed to, and he will find his course is not nearly as limited as in previous flights ; in other words he will be able to wander about in all directions.

One effect of height is that the ground beneath appears to be moving very slowly

with the result that there is a tendency to increase flying speed. This is the time when the pupil learns to *disregard the ground speed*, or, more correctly here, the apparent ground speed, and learns to *rely solely on air speed*.

As the glider passes along the ridge it will be pointing away from the hill to some extent in crab fashion, the higher the wind the greater will this angle become till when the wind speed equals the forward speed of the machine it will point directly away from the hill, and hovering takes place.

Under these conditions the wind velocity will be in the neighbourhood of 30 m.p.h., and this is the safe limit in which flying should be done at this stage.

The descent to land will take longer, but should be done in exactly the same way as previously described except that the distance away from the hill-face might be increased. One advantage of a high wind is that the final glide in to land will be much shorter, and can therefore be commenced earlier.

Duration Soaring Flights.—After gaining the

'C' certificate the pilot should, when opportunities occur, carry out practice flights of longer duration, starting with flights of twenty minutes to half an hour, and extending this later to one hour and two hours.

In the half-hour flights the pilot will become thoroughly accustomed to handling the machine, improve his turns, and generally gain air sense, whilst in the longer flights he should search about for the best up-currents note the effect of various hill formations on the airflow, find out the extent of the up-wind area (as determined by his machine of medium efficiency only), and watch particularly for the effects of passing showers and clouds; for, if he is observant, he will notice alterations in wind speed, direction and buoyancy under the last mentioned condition.

CHAPTER VIII

SAILING

The Sailplane.—The true sailplane is a glider of the highest known efficiency, capable not only of descent at a very small rate, called sinking speed, but also possessing a very fine gliding angle, so that a large forward distance is covered for a relatively slight loss of height.

Machines with a low sinking speed, not possessing a fine gliding angle, are incapable of long cross country flights and cannot, therefore, be regarded as sailplanes.

The wing-loading of sailplanes is rather higher than that of intermediate types, which is due partly to their greater span and partly to the strength requirements for storm and cloud flying. The average span is large, being over 50 feet, and all parts are faired, or streamlined, to the maximum extent.

As a rule the wings are tapered, as this allows a lighter structure weight, and at

the same time gives greater aerodynamic efficiency.

Sailplane Types.—The ‘Professor’ was one of the earliest successful sailplanes to be used for constructional work; in fact it can be said to be the prototype of the modern machine. The wing, of two-spar construction, is built in three parts, giving a total span of 54 feet. The central portion, which is supported by ‘V’ struts, is of parallel chord, whilst the two outer parts taper considerably.

The fuselage is of the well-known hexagonal shape, with ‘pendulum’ type elevators and a small built-in vertical fin.

A very pleasant machine to fly, and capable of considerable performance, it has, nevertheless, been found rather liable to spin on slow turns. This may be rectified, to some extent at least, by increasing the aileron chord at its mid span, and so bowing the aileron trailing-edge rearwards.

Kronfeld’s ‘Wien’ was a development of this type, and had an increased span of 63 feet together with an oval shaped fuselage.

The ‘Tern’ has a cantilever wing of normal

two-spar construction, with continuous taper from root to tip. A short centre-section is built-in to the fuselage top, to which the outer sections are bolted by two vertically placed bolts in each wing.

The plywood covered fuselage is of rather large cross-section and provides a comfortable cockpit for the pilot, but inevitably gives rise to rather large parasitic drag.

The rapidity with which this sailplane can be assembled is an outstanding feature, and is due largely to the automatic inter-locking of the aileron and elevator controls as the wings and tail are assembled.

The 'Crested Wren' was the original machine of this type, but certain minor modifications have been incorporated in the later-day 'Willow Wren'. A rather lightly loaded machine, with a small aspect ratio for sailplanes, the 'Wren' flies well in light winds, and has proved itself easily capable of high performance work.

The wing is built in two sections and is provided with a single spar with forward torsion tube, but towards the root the torsion

box connects up with a light secondary spar, the loads then being transmitted through two sets of fittings to corresponding bulkheads in the body. Single lift-struts support the wing.

The fuselage is plywood covered, of hexagonal section, and has small built-in horizontal and vertical fins, to which the single elevator and rudder attach.

The Dunstable 'Kestrel' sailplane is a later development of the successful 'Wren' series of gliders, and is one of the best British machines. In general construction the 'Kestrel' differs little from the 'Wren', but the great simplicity of erection and dismantling forms an outstanding feature, whilst improvements in general robustness and aerodynamic shape have been incorporated. Both the gliding angle and the sinking speed are remarkably good, so that the 'Kestrel' is well suited for thermal work and soaring in light winds.

The 'Scud II' has the remarkably small wing area of 100 sq ft, and in consequence the wing-loading is very high. However, a 40 ft span and small tapering chord result in a high aspect ratio with low total drag,

which brings the machine into the high performance class.

The wing is made in two lengths and is supported above the fuselage by oval steel struts. Single-spar with torsion resisting plywood covering, passing back to a light secondary spar, provide a very robust wing for so small a chord.

The fuselage is rather unique, and consists of four longerons, plywood covered, giving a square section, but stood on one edge, diamond fashion. There are no fixed tail surfaces and differential aileron control is fitted.

The 'Rhönadler' is one of the latest and most popular German sailplanes and is capable of very high performance. Simplicity of layout and construction is its keynote.

The 57 ft span wing is pure cantilever, and attaches directly to the fuselage by a short 'neck'. Continuous straight taper from roots to tips is employed, which gives the sailplane a very pretty appearance in flight. The body is well shaped and of oval section with a small fixed vertical fin and pendulum elevators.

The 'Kassel Two-seater'. This machine

is the best known two-seater sailplane. The necessary large wing area does not allow the employment of a high aspect ratio, but the machine soars well with one or two occupants, and distance flights have been carried out with this type.

The wing is of normal two-spar construction and is supported by two pairs of struts. The end few feet of wing taper to some extent.

A vertical fin is built in to the hexagonal fuselage and a 'fixed' tail plane is provided.

The heavy wings, and small amount of taper cause large inertia forces which give rise to somewhat sluggish turning qualities.

'Stedman Two-seater'. The lay-out and general construction of this two-seater machine follow very closely along the lines of the 'Kassel'. The loading, span and aspect ratio are all slightly higher.

The main difference is the deletion of a fixed tail surface; the elevators being entirely pendulum.

The main particulars of the sailplanes best known in this country are given in the following table.

PARTICULARS OF LEADING SAILPLANES

Type	Total Weight, lbs	Wing Area, sq ft	Wing Loading, lbs sq ft	Span, ft	Aspect Ratio
Professor .	500	200	2.50	52.75	13.9
Tern . .	415	201	2.06	50	12.4
Kestrel . .	340	150	2.27	40	11
Scud II . .	330	100	3.30	40	16
Rhonadler .	540	194	2.79	57.1	16.8
Kassel, 2-Seater .	700	290	2.31	49.17	8.34
Stedman, 2-Seater .	720	290	2.48	50	8.62

First Sailplane Flights.—The first few flights in a high-efficiency machine should be confined to gliding, with no attempt to soar, and should not be made from any appreciable height. If, as is most usual, the elevators are of the pendulum type; that is to say there is no fixed tail plane; the pilot will find great sensitiveness on the elevator control, causing a tendency to ‘hunt’, but this will be overcome after a few flights on a gentle slope.

After this some flights may be made from the hilltop, when very little wind is present, the pupil being instructed to lose his height by gliding up and down, parallel to the hill, with a final turn into wind for landing.

A steady wind, of moderate intensity, should

be chosen for the initial soaring flight on a high-efficiency type glider. The pilot should be limited still to the confines of the soaring training site, until his turns have been perfected, after which he should be allowed to make longer excursions under the directions of the instructor.

Launching.—The launch of a sailplane is made in a very similar manner to that used for elementary gliders, except that a stronger team is required, owing to the greater weight.

A loaded sailplane is roughly half as heavy again as a glider used for training, apart from which a more vigorous pull-off is both safer and enables a greater initial height to be gained. Teams of five are necessary for a clean, safe launch and can be increased up to seven, or even eight, for obtaining a good height for soaring in little wind. A crew of at least two is required for the tail.

Double launching elastic is much preferable for this purpose than the single elastic used for earlier flights, and prevents unduly rapid deterioration.

The sailplane should be placed well behind the crest of the hill, facing into the wind. It is advantageous to turn the nose of the machine slightly to one side of the wind, as this considerably helps the first turn.

The number of walking and running paces can be increased for the larger team with the double shock-cord, and so ensure a clean take-off. After the release the stick should be held in the central position for a fraction of a second, but, as soon as a reasonable speed has been obtained, it should be pulled back so as to lift the skid clear of the ground. This can be done by a small jerk and as soon as the machine is air-borne the stick is moved forward so that the machine remains close to the ground until the elastic falls off. In this way the maximum amount of energy is extracted from the launch.

Directly the elastic clears the hook a steady climb is commenced, and retained until the speed falls to normal, when the stick is centralized once more.

The turn is then started, or it may be made during the climb, and if the launch has been



LAUNCHING THE "TERN" SAILPLANE.

correctly timed the machine will now be within the strongest soaring currents.

Turning.—The pilot has already learnt to execute neat turns, first on the slow-responding primary glider, and then on the more controllable secondary machine, so that he should not find much difficulty with a sailplane.

There, are, however, one or two points worth mentioning, which should be borne in mind.

The turn should not be hurried, as more height is likely to be lost in a tight turn, due to the banking, than in one with little bank which takes the pilot away from the hillside.

If a turn is made at very low forward speed, the inner wing-tip is liable to stall owing to the reduction of speed caused by the smaller radius of turn. This effect is quite noticeable and such conditions should be avoided by a judicial adjustment of speed.

A somewhat similar effect can often be detected when flying along the crest of a ridge with the wing-tip quite close to the hill. In this case the wing adjacent to the hill is subjected to an extra drag due to the unsteady air

conditions, whilst there is also an increased lift on the other wing owing to the greater intensity of up-current away from the hill surface.

Application of opposite rudder merely adds to the total drag forces ; the better method of correction being by gentle bank away from the hill. This also acts as a precautionary measure, since a turn away from the hillside, in the event of meeting with some air pocket, or disturbance, is thereby facilitated.

Increase speed slightly *before* commencing the turn, and complete the turn by holding the stick back, but without going too close to the stall. Give a little bank only, and prevent over-banking by 'holding-off'. One cause of over-banking was explained in Chapter VI and, with sailplanes of large span, the effect is aggravated owing to the higher velocity of the wind in which the up-turned wing is acting.

Some pilots start the turn by first moving the control column slightly in the direction *opposite* to the turn. This puts the machine in a bank opposite to that required, but the greater drag of the down-going aileron starts a

yaw towards the desired direction. Opposite bank and rudder are then applied for completing the turn. Some machines seem to respond to this, but where differential aileron control is fitted the effect is largely lost and is moreover unnecessary.

There are other manœuvres that should be learnt at this stage, although they may be first practised on intermediate machines if desired.

Sideslipping.—The sideslip is of great assistance when landing in confined spaces, or for quickly losing height, and can be practised at the termination of a soaring flight.

The sideslip is simply a method of increasing the sinking speed with no appreciable alteration of the forward velocity, *i.e.*, a course gliding angle is obtained, and it has the great advantage conferred by the retention of full control.

To effect a sideslip, the machine is first banked at some angle, by movement of the control stick. The nose tends to fall, which, if allowed to develop, would place the aircraft in a diving attitude, but this is prevented by the application of 'top' rudder; that is

to say the rudder is moved in the opposite direction to the normal for a turn, and thus tries to lift the nose by depressing the tail.

The amount of bank and rudder must be adjusted so that a steady sideways descent is

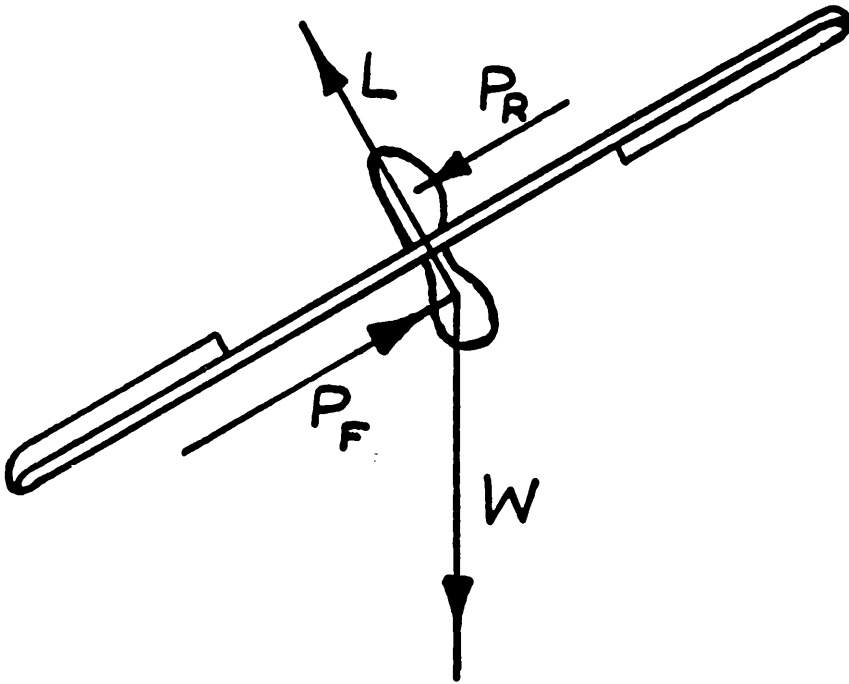

FIG. 24.—Forces Acting in a Sideslip.

made ; the forward speed remaining practically constant, or just slightly increased.

Figure 24 shows the forces acting on a glider during a sideslip. It will be noticed that the lift, L , decreases as the rapidity of slip is

increased, and likewise the pressure, P , on the side of the machine increases, so that the weight, W , is balanced by a force made up of components of P and L . (Fig. 25.)

Gentle sideslips of short duration should be tried first, taking care to right the machine in good time, although it will quickly be found that the glider returns readily to its normal

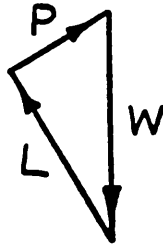

$$P = P_F - P_R$$

FIG. 25.

glide when the controls are returned to the central position.

Sideslips are usually made into wind; that is with the leading, or down-turned, wing-tip facing into the wind; so that the pilot can keep his eye on his intended landing point the whole time. A few feet from the ground the machine is faced directly into wind, levelled off and landed.

In the case of sailplanes, with little fuselage side area, and especially when the fuselage section is oval or circular, the air resistance to sideways motion is small, and height can best be lost by a series of sideslips, first to the left and then to the right; in each case the slip being made towards the landing point.

This manœuvre causes considerable upsetting of the airflow, with the formation of eddies, and thus enables height to be lost without necessitating too high a velocity.

Tail-Swishing.—This is another method of increasing the angle of descent without a corresponding increase in speed, and is particularly useful when effecting a landing on the hilltop. It should only be used when fairly close to the ground for throwing off the last few feet of height.

The tail is moved alternately to the left and right by means of the rudder, with a little opposite aileron to prevent the outer wing from rising.

Actually the course of the machine is lengthened, on account of the curved path followed, apart from which the airflow over

the whole machine is not allowed to remain steady, and hence a coarser glide results.

Another advantage of this approach is that the pilot gets a good view of the ground ahead, without being obstructed by the nose of the fuselage, and is thereby better able to avoid small obstacles.

Landing on Hilltop.—If the top of the soaring hill is large, reasonably flat, and clear of obstacles, a landing can be made there much easier than at the base, and is done by flying over the hill, down-wind or better still cross-wind, until within a few feet of the ground, when a turn into wind is made followed by a normal landing.

There is generally little or no up-current beyond the crest of the hill and, therefore, the sailplane glides down at its normal gliding angle. Very often down-currents and eddies are experienced, due to the curling over of the wind, and these can be used to accelerate the descent.

These disturbed conditions may also be a source of danger, and should be prepared for

by a slight increase in speed in order to obtain greater controllability.

The higher wind velocity at the top of the hill gives a coarser gliding angle when flying into wind, but, if the turn-in to face the wind direction is made too soon, the glider will come again within the influence of the up-currents, in which event the soaring flight should be continued, and a further attempt made to land.

Much greater skill is required where the available landing space is restricted, and recourse to sideslipping and tail-swishing is often essential. Flying behind the hill may not be possible, since a forced descent before reaching the desired landing spot might be inevitable, and hence some other method of approach becomes necessary.

One way is to increase the gliding angle by some increase of speed, in which case the height loss should be gradual ; whilst another method is to fly out from the hill until about level with the crest, or even slightly below, and then return, so as to pass over the top by a few feet only, which can then

be slipped off by the methods described above.

Where the top of the hill is undulatory, a safe landing can be made by flying below the top of the highest part and then turning in over the lower ground with a final turn towards the up-slope on which the landing can be made.

A gentle upward slope is of great assistance in landing, under all circumstances, as once the sailplane is below the top a quick landing can be made with a very short run. Conversely downward slopes should be avoided as they add to the difficulties.

Unless the wind is high it is generally better to land down-wind and up-hill than vice versa.

A good pilot can effect a landing in a desired spot by flying just over the brow of the hill, that is just out of the main up-wind, and keeping the sailplane in a crab-wise position, slowly losing height the whole time. The machine is allowed to drift to the back of the picked spot, and is then turned into wind and landed.

Spinning.—Spinning is brought about, either

purposely or accidentally, by allowing the aircraft to get into a stalled condition. Deliberate spins in power machines are assisted by putting on full rudder, but most aircraft unless slotted spin automatically if held in a stalled attitude. This is brought about by a greater drag on one wing than on the other, and may be caused by aileron movement (unequal drags), or disturbances in the air.

Once the spin is started the outer wing obtains an increased lift, owing to the greater speed, and, similarly, the inner wing remains stalled, so that the spinning motion tends to continue. This is known as autorotation.

The sailplane pilot is not interested in the procedure for placing a sailplane in a spin, but *he should know how to get out of a spin since they are sometimes started involuntarily.*

To check a spin, centralize rudder and ailerons immediately, and hold the stick slightly forwards. It is often possible to accelerate the recovery by applying rudder opposing the direction of the spin, but, unless it is taken off at exactly the right moment, the machine may change over to a spin in the

opposite direction. Also, if the stick is held well forward, the final dive is made at an unnecessarily excessive speed.

An inexperienced pilot, who suddenly finds himself in a spin, cannot do much better than to centralize all controls.

Unless impact with the ground is imminent, the pull-out from the resulting dive should not be abrupt.

Height is rapidly lost during a spin, and for this reason no pilot should attempt to spin a sailplane for the sake of gaining experience, unless he has exceptionally good height, but it is recommended that some instruction should be sought on light aeroplanes.

Instruments.—At this stage there are certain instruments which will be found of great assistance.

The most essential instrument is a sensitive *air speed indicator*, as by means of this the pilot is able to fly at the particular speeds most suited for soaring flight; gliding flight over country devoid of up-winds, and gliding flight for maximum distance down-wind.

The next important instrument is the

variometer, which indicates rises and falls in altitude and the rate of change of height. This enables the pilot to pick out the best areas of rising current, and to remain within them until the maximum height has been obtained.

An *altimeter* shows the height during the whole flight, and it is often on this knowledge that the pilot bases his decision to continue a flight, or to change his course to some known, or expected, source of lift. The height indicator also shows whether height is being gained or lost, but is not very sensitive and does not therefore show up small changes of rate of ascent, and descent.

Lastly a small *compass* is of assistance on cross country flights. There are other instruments that are sometimes fitted, such as the *cross-level*, *turn indicator*, *etc.*, but these are not considered essential, although they are important if cloud flying is to be carried out.



THE "RHÖNADLER" IN SAILING FLIGHT.

CHAPTER IX

EXTENDED SAILING FLIGHTS

One of the pilot's first impressions on flying a high-efficiency sailplane is that he is not limited to the narrow confines that were enforced by the secondary machine.

The soaring glider is not able to travel far from the up-wind slopes without a rapid loss of height, and, in fact, there appears to be a narrow belt of up-current, with very clearly defined boundaries. The sailplane with its low rate of sinking speed, suffers from no such rigid demarcation, and the pilot is free to wander about in all directions to a far greater extent.

This should be taken advantage of by making excursions along, and, when height permits, for some distance away from, the hills.

Contour Sailing.—The easiest method of carrying out a distance flight is by continuous soaring along the windward side of a line of

hills, and, provided that the hill shape is suitable, and that it runs in a straight line so as to face, more or less, into wind throughout the length of the range, then a flight of several miles can be made without difficulty.

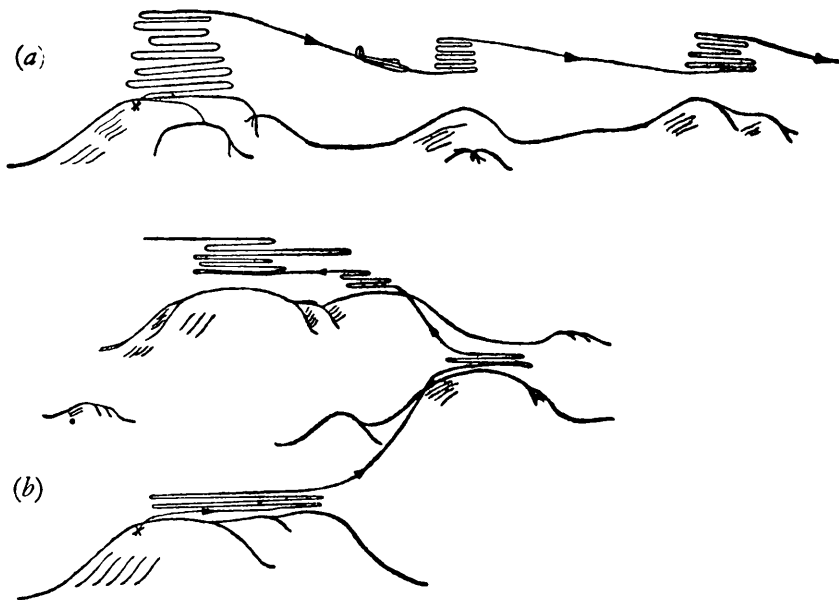

FIG. 26.—Hill Soaring Flights.

The advantage of such flights is that a return along the hills can be made to the starting point, thus saving much time and labour that would be involved in transporting the machine back by road.

Gaps between the hills can be bridged by

soaring to a considerable height before leaving one hill, followed by a fast glide to the next where the process can be repeated. (Fig. 26(a).)

Sometimes it will be necessary to hover over one hill for several minutes, waiting for a favourable gust, before the required height can be gained. Both skill and patience are needed for success.

Where a series of separate hills, or ranges, exists, one behind the other, with the wind direction such that it passes over each in turn, a down-wind flight is possible. (Fig. 26(b).)

In this case, the maximum initial height is obtained over the first hill, after which a down-wind course for the second hill is followed. The shortest path is not necessarily the best, as a slight detour, to avoid the leeward eddies and down-currents of the first hill, may be well worth while.

The process is repeated at each succeeding range.

It is sometimes possible to make the return journey also, but this is much more difficult, and can only be done under very favourable conditions.

Cloud Flying.—After a few such flights have been carried out, during which the effect of winds, in different strengths and directions, on the various land configurations have been tried out and noted, there will be still further surprises awaiting the keen pilot. A sudden and mysterious gain in height, for no apparent reason, may puzzle the pilot, whereupon he will look about for some explanation, and will probably notice a large cloud passing overhead—a new experience awaits him.

A considerable distance may separate the cloud from the sailplane, but, nevertheless, its influence may be distinctly felt. Keeping under the cloud the pilot should leave the hill up-winds and, carefully holding the sailplane at its best attitude for minimum descent, he should trace a new course, watching, the whole time, his height indicator, variometer if fitted, and his familiar home-hills.

If height is being gained all is well, but if it is being lost a change of direction should be made, ever searching for helpful currents. As the cloud passes, so will descent commence, whereupon an attempt should be made to

regain the hill region, and so continue the flight by contour soaring. If the hill is too far

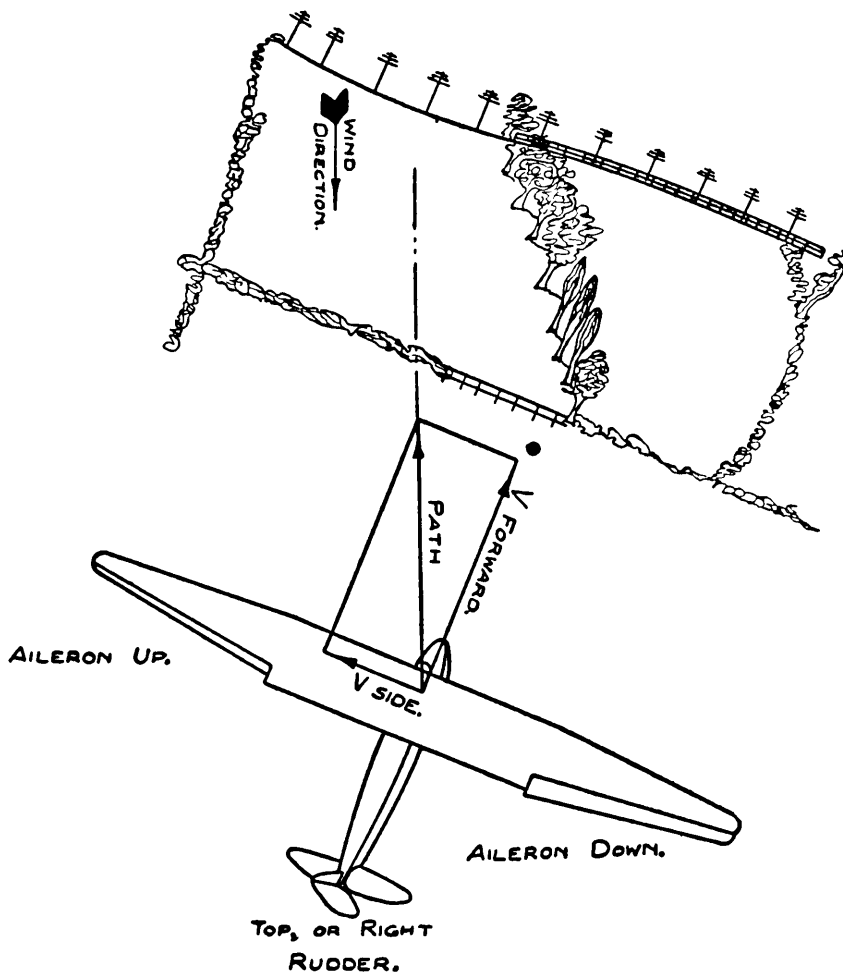

FIG. 27.—Landing Approach by Means of Sideslip.

away, the landing ground should be made for, and failing this a large field should be quickly

chosen, and an approach made from the leeward side.

On the next occasion, probably, the pilot will be on the look-out for his cloud and will endeavour to reach a greater height before it approaches, so as to be able to make definite contact with it. This time he should fly towards the front of the cloud, where exist the strongest up-currents, and remain in this region for as long as he may, moving along with the cloud.

If he is sufficiently near, he will be lifted close to the cloud by the rising currents to which the cloud owes its formation, and may then travel with it across country for, perhaps, five or ten miles.

At length he may find his source of sustentation beginning to dissipate, when he must either set out towards another cloud formation, this time flying at the best angle of glide, or prepare for landing.

The best angle of glide, referred to in the last paragraph, will depend on the wind speed and direction relative to the flight path, and will not necessarily be the best angle for the

machine in still air. For example, if the course is directly against a head-wind, some increase in speed will give a coarser gliding angle relative to the air, but may well result in a finer angle of glide relative to the ground, and hence a greater distance over the ground will be covered for a given loss of height.

In general the flying speed should be increased when flying against the wind, and decreased for flights with a following wind.

If the cloud up-currents are of sufficient intensity, the sailplane may be carried up into the cloud, and even right through to the top, but it might be better to avoid this until greater experience has been gained. The currents within a cloud are somewhat violent, and cause rapid upward and downward accelerations of the machine, apart from which, unless special instruments for 'blind' flying have been installed, the pilot loses all sense of direction and balance, and may easily get into a spin, or some other unpleasant flight attitude.

Up-currents are associated with most clouds, but the larger woolly cumulus of the summer months, that form under sunny conditions,

with a blue sky as background, are the most suitable for sailing flight.

Line squalls, or cold fronts, are cloud formations that advance as a line of cloud. They are generally formed by a cold west, or north-westerly, wind which impinges on warm air, causing it to rise, with condensation of the moisture content, and the consequent formation of cloud.

These squalls are often accompanied by hail and thunder, and often occur in succession, or waves. They quickly pass, leaving the air completely still, but cold.

Along the front of the squall is a belt of rising air similar to the hill up-winds along a ridge, and in this the sailplane pilot can fly, moving the whole time up and down the line of cloud, but always keeping clear of the front.

Thermal Soaring.—Another mysterious source of lift is due to thermal currents caused by convection, and here again the pilot might suddenly encounter the phenomenon unexpectedly. Just after sunset, especially after a sunny day, the air generally cools fairly rapidly, whereupon the stored up heat of the earth is

liberated which thus warms the surrounding air and causes it to rise.

The sailing pilot may fly away from the hill in order to descend, when, to his surprise, he finds that instead of losing height, he retains his altitude, or even soars higher, and this may often take place despite a failing wind. This is his first experience of thermal effects.

If a ploughed field, or a field of ripening corn, lies below, or near, the soaring hill, it may be noticed that greater height can be obtained when flying above than when over grassland. Bare earth, corn, gorse in flower, etc., do not retain much of the sun's heat, but radiate it to the surrounding air. When the sun becomes hidden, however, lakes, rivers, marshes, green corn, etc., give off their accumulated warmth, and thus cause a reversal of air-flow.

The passage of a large cloud across the sun's rays is often sufficient to set up a system of thermal currents in the region covered by the shadow.

Unfortunately, it is impossible to see these vertically moving columns of air, so that their

detection is difficult besides which our knowledge on the subject is very incomplete. Nevertheless, the pilot should be ever on the lookout for this source of lift by flying towards likely areas, and, once found, they should be exploited to the fullest extent by circling flight within the boundaries. The variometer is indispensable for the detection of convection up-winds.

The use of thermal winds for distance flights has only recently been used knowingly, but there seems little doubt but that ultimately they will prove to be the most valuable means of sailing flight.

It should be remembered that actual sunshine on the earth's surface is not essential for convection to take place and that any difference in temperature in different parts either of the air, or of the ground, or any variation in the quantities of heat present in adjacent areas, must set up thermic flow. This means that convection soaring is possible both in summer and winter, although, obviously, warm sunshine provides the most favourable conditions.

Birds, probably, understand very little about the formation of these upward currents, although they find out to some extent where and when to expect them. Having come across such a means of gaining height without the need of flapping, it is usual for them to remain circling in the vicinity until the maximum height has been reached, or until no further support appears to be offered. Therefore, whenever birds are sighted in circling soaring flight, the pilot will do well to fly in their direction to investigate the conditions.

It may be noted that cumulus clouds already referred to are formed by rising currents of warm moisture-laden air, which, by coming into contact with the upper colder regions, cause the moisture to condense into small particles and thus form the cloud.

These up-winds may be thermal, or they may be caused by the upward deflection of a horizontal wind through the presence of hills or cliffs—this latter process being not unusual along the sea coasts when the wind blows towards the land—or there may be a combination of both causes.

However, once the cloud is formed, a certain internal circulatory flow seems to continue, for some time at least ; the direction of flow being upwards at the front of the cloud and downwards at the rear. This, incidentally, accounts for the continued process of formation that can be witnessed along the leading edge of a cloud, whilst at the back small wispy pieces can be seen to break away and disappear.

Cross-Country Flights.—The longest flights, so far, have been made by a combination of the methods explained.

Generally, the initial height has been obtained by hill soaring, after which the course has followed, more or less, along a line of hills, or has been set from hill to hill.

Advantage is taken of cumulus clouds met with *en route*, for the extra lift obtainable, or for crossing from one hill to another.

On some occasion the start is made from flat country by means of aero-towing to a height of one or two thousand feet, or even more, after which the pilot flies from cloud to cloud, if present, or picks out ascending thermal winds, whilst hill up-winds are always

exploited to the fullest extent. Auto-towing has also been used for the start of a flight, but it is not often that sufficient height can be gained by this method.

On a sunny day fields of corn, stubble or ploughland are chosen for flying over in preference to green meadows, marshland, etc., and the country lying near to rivers and lakes may give rise to ascending currents to compensate for the downward flow over the water. Woods and forests absorb much heat in the early part of the day, but, after a while, a saturation point is reached, and when the sun becomes hidden, or again after sunset, the stored-up heat is liberated, which results in a strong upward flow.

A large slope, or the side of a hill, facing the sun is subjected to a larger amount of heating, per horizontally projected area, than flat country. In other words the sloping surface receives as much heat, or more, depending on the inclination of the sun's rays, as the surrounding parts, and since a certain amount of this heat per unit of area is radiated to the air, and the volume of air above an area of sloping

land is less than that over an equal area of flat surface, the quantity of heat must be greater over the sloping ground. Hence the intensity of the up-current must be increased also.

Conversely the hillside sheltered from the sunshine, or on which the sun's rays fall obliquely, will not give rise to favourable air currents and should therefore be avoided.

Flights made in the van of a line squall or thunderstorm have to take the direction in which the storm travels, although, having flown to a great height by the aid of a storm, the course can be set in any desired direction and may, of course, be continued by any other methods of soaring flight.

CHAPTER X

AUTO-TOWING AND AERO-TOWING

Auto-Towing.—Or towing by means of a motor-car, is used principally as a means of training, although by its aid heights of 500 to 1000 feet are obtainable, provided that a long enough run over level ground is available, and thus enable sailing flights to be initiated by this means.

Another use for auto-towing is for starting soaring flights over hills, cliffs, etc., where the higher ground is not suitable, or available, for launching. So long as reasonably flat ground is present at the base of the hills, this method may be used for obtaining the necessary initial height, and on the release of the cable the pilot flies towards the hills, where he is able to continue in soaring flight.

Much discussion has taken place concerning the relative merits of the auto-towed method of training and the shock cord method, and

there are undoubted advantages attached to the former method, which may be summed up as follows :—

1. Freedom from violent acceleration
2. Longer flights possible at all stages of training
3. Pupil under control of instructor
4. More flying time
5. Less manual labour, and smaller teams required
6. Training largely independent of wind

Against these must be set the disadvantages of a large flat field being an essential part of the training site, and the greater cost involved in the maintenance, and running, of the car. If these drawbacks can be satisfactorily overcome, then resort to auto-towing will enable greater activity, and speeded-up results to be achieved.

Auto-Towing Apparatus.—The field, beach, or training ground should be at least 3,000 feet in length, and, if work is to be carried out in all winds, this run is necessary in all directions.

The surface should be level ; free from ruts, and well drained. Soft or waterlogged ground

is useless. Also the towing car should make one or two trial runs across the site before commencing actual operations. Chains may be fitted to the driving wheels of the car when the ground is wet, to prevent wheel-spin.

The car should be powerful, and capable of rapid acceleration ; this latter quality being of great importance when training pupils. Any necessary gear changing should be made before the glider leaves the ground.

For towing cable, either $\frac{3}{8}$ inch hemp rope or 10 cwt extra flexible steel cable may be used, and pieces of bunting should be firmly tied on at every 50 feet, so that the cable may be easily seen by the pilot, car driver, and others. The ring on the end of the cable should be about 2 inch in diameter, by $\frac{5}{16}$ inch thick.

Quick release mechanism must be fitted at both ends of the cable ; that is on the nose of the glider and at the towing car ; the latter being essential in the event of the pilot forgetting to cast-off, or in case the mechanism refuses to act. These releases should be quite simple in action and operable by pulling a wire or lever. There must be no possibility of the

cable getting caught on the glider's release or on any other part of the machine.

All types of gliders can be used for auto-towing, provided that they are strong enough, but the closed-in type—*i.e.* fuselage, or nacelle, models — are preferable. Landing wheels should be fitted to overcome the excessive friction of the main skid. Two wheels are best for training as they facilitate lateral balance being maintained when on the ground, render unnecessary a wing tip assistant, and are of great assistance when towing and wheeling the machine about.

For advanced work a great reduction in air resistance is possible with one wheel, especially if this is built into the main skid, so as to protrude a few inches only below the base. The wheel or wheels should be placed so that the point of contact with the ground is close to the vertical line passing through the centre of gravity of the glider, and so that the machine can incline forwards, or backwards, on to the skid for reducing speed on landing.

As all flights should be made directly into wind, and since the wind velocity should always



THE FIRST BRITISH SAILPLANE "ALBATROSS" (1930) EQUIPPED FOR TOWED FLIGHT.
Designed by the Author.

be taken into account for determining the speed of the car, it is a good plan to mount an air speed indicator on the car dashboard, with the pitot head, or venturi tube, attached some feet above the car. A short post driven into the ground at the starting point, on the leeward side of the flying field, will be found most advantageous for getting the towing cable back into position. The car, to which one end of the cable is attached, is driven round the stake and then directly into wind so that the cable is lined up between the post and the car. A large pulley or roller can be made to work on the post to reduce friction and wear.

Lastly, auto-towing should only be carried out when a capable instructor superintends its use. The car should be in the hands of a steady driver, who will act immediately in accordance with the orders given by the instructor.

The instructor should take up his position next to the driver, but facing backwards towards the glider.

Training by Auto-Towing.—The pupil is first given some taxi-ing practice, equivalent to the 'ground slides' of the shock-cord method,

for which purpose a cable of 100 to 150 feet in length can be used. The glider is pulled along behind the car at a uniform speed that is just too low to allow the machine to become air-borne.

He is told not to move the control column, but to maintain a straight course by means of the rudder. In this way he quickly gets used to the rudder control.

After a few flights the elevator is brought into play for holding the glider in a horizontal position, still without leaving the ground. This is followed by an equal number of flights, just clear of the ground, with the pilot holding the stick in the central position, the height, and return to the ground, being controlled by the speed of the car. On no account is the pilot allowed to operate the release at this stage, and any tendency on the part of the pupil to climb too high should be counteracted by a reduction in the speed of the car.

Lateral balance has to be retained by the pilot with the aid of the ailerons, whilst any tendency to swing sideways can be corrected by a small acceleration of the car speed,

for which purpose a fairly short cable is beneficial.

After a total of 15 to 20 flights, the pilot is allowed to attain a height of from 10 to 20 feet, after which he releases himself; glides down, and lands. This is equivalent to the normal launch on fairly level ground as given with the shock-cord method of training, and is the most critical period of this method of training.

As soon as the pupil has shown himself capable of using the controls properly, judging the correct gliding angle, and making a good landing, the height is steadily increased to first 50 and then 100 feet; the cable length being increased to 250 feet for this purpose. Since the glider has further to travel than the towing car, the speed at which the latter is driven should be slightly decreased after the glider has left the ground.

At this stage some gentle turns can be attempted, by the aid of bank and rudder; a turn through approximately 45° being followed by an equivalent turn in the opposite direction so as to face the glider into wind

again for the landing. No turn should be commenced while the cable is still attached.

Some 'S' turns can then be practised from a height of about 150 feet, and on calm days semi-circular turns should be practised, so that the pilot lands down-wind.

After thirty or forty flights have been made satisfactorily by each pupil, the cable can be again lengthened to 500 feet, which will enable heights of from 200 to 300 feet to be attained, thereby allowing the pilot to make a complete circuit of the aerodrome, after casting off, and to land near his starting point.

Where a sufficiently large ground is available a 1,000 ft cable can be fitted, so that climbs of over 600 feet can be accomplished, and, when conditions are suitable, some thermal soaring becomes possible. Apart from soaring, however, flights of about 4 minutes' duration can be made with an efficient glider by this method.

The first gear change may be made before the glider leaves the ground, almost immediately after the start, but the second change should

not be made until the glider has gained a height of at least 50 feet.

High winds should be avoided during the early part of training by auto-towing, or the pupil is liable to turn across, or down, wind with serious results. Gusty wind is even worse than a steady high wind, as the glider may be lifted off the ground by a gust, without the car having attained a sufficiently high speed, and this may cause a stall as the gust subsides.

Calm conditions, with little or no wind, are ideal for the purpose since flying is not then limited to one direction only and flights may be made in both directions, or in succession round the aerodrome.

In towed flight it is a good plan for the pilot to fly just to one side of the towing vehicle, in order to keep his eye on the cable, and it is important that the cable should be seen to fall before any manoeuvre is commenced.

It is not sufficient merely to pull the lever or wire operating the release, since, in the event of the cable remaining on the hook, a serious accident is likely to result. The bunting

attached at intervals to the cable helps the pilot to see the falling cable.

If the cable should remain jammed, so that the pilot is unable to free the machine, then he should descend by a spiral path keeping the towing car in the centre of the spiral, as the centre of turn, and so land.

It is just as important for the instructor to watch for the release at every flight, and in the event of failure he should immediately release at the car end. If the pilot knows that the cable has been disconnected at the lower end, he should remain within the boundaries of the aerodrome to prevent fouling the cable, and should carefully avoid passing over hedges, trees, or other obstacles that are likely to catch the cable.

In the very unlikely event of the cable remaining stuck at both ends, the car should be driven so as to follow the glider as closely as possible, while the instructor should endeavour to effect the release, or sever the cable.

There still remains the expediency of diving steeply and flattening out just off the ground, and so snapping the cable. This emergency

measure has been used with success but requires a high degree of skill, and is, even then, attended with grave risks.

The Auto-Towed Start for Hill Soaring.—Contour soaring can be started from either the bottom or the top of the hill, by means of auto-towing, provided that suitable ground is available.

The advantage to be gained by an auto-launch from the hilltop is that it enables a much greater height to be obtained than is possible with a manual launch, so that on days when little wind is present it may be possible to gain the upper air, and thus soar.

An auto-towed launch from the foot of a hill is of value when the hill is covered with trees, and rocks, or, alternatively, is not available for launching from the top.

A launch from the hilltop by this method should be arranged so that the sailplane obtains the maximum height just before the towing car reaches the boundary, and if the pilot has not released by that time, the car should be turned along the ridge until the release is made.

Launches from the base should be commenced with the sailplane as close to the hillside as can be arranged, and the pilot heads for the up-wind area immediately after the release.

Winds blowing obliquely on to the hill generally are the most suitable for the auto-towed launch, both from the top and from the bottom of the hill.

Mechanical Launching.—Besides the auto-towed launch described above, there are other methods of mechanical launching that are carried out with the aid of motor-cars, both moving and stationary, and even with stationary engines fitted with winding drums.

The simplest, and perhaps safest, mechanical launch is made by driving a car forward, in place of the normal launching crew, with the double length of shock cord attached to the car and a length of from 100 to 300 feet of rope between the elastic and glider. The elastic is sometimes placed between the cord and the glider, but possible damage to the pilot and machine, in the event of a breakage in the elastic, is avoided by the former arrangement.

To prevent overstretching of, and damage to, the shock-cord a small flag or mark should be placed ahead of the elastic at a distance equal to the length of the shock-cord, so that the release can be arranged for directly the elastic is stretched to the double length.

It is a wise plan to arrange for the car to be driven always to the left, as soon as the glider is clear, in order to avoid possible collision.

The shock-cord need not necessarily be limited to two lengths, but may be increased, up to, say, six in order to obtain a stronger launch, but the tail crew should not be over-strong, and may well be limited to two persons for primary and secondary machines, and to three for sailplanes. This acts as a good safety measure and overcomes the liability of too vigorous a launch being given, since the tail crew is unable to exert too great a retaining force.

Where several strands of shock-cord are used, the failure of one does not appreciably affect the launch, and for this reason old or worn elastic cord can be made to serve.

To prevent wheel-slip, and allow better

acceleration of the car for a strong launch, the shock-cord may be folded back before the start, so that the car can gather speed while taking up the slack. In this way a strong continuous launch is obtained which enables a height of about 50 feet to be attained from flat ground with no wind.

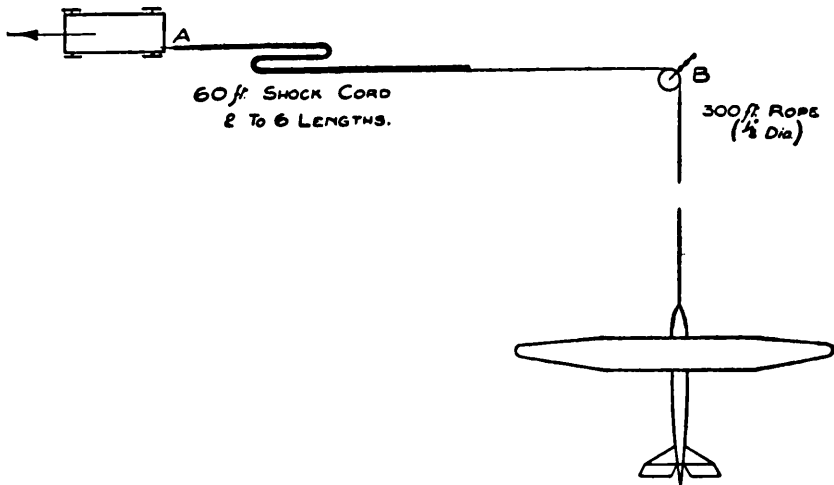

FIG. 28.—Auto-Launch.

The wind velocity should be ascertained and allowed for in any method of mechanical launching, or too vigorous a launch may be given unwittingly.

The above method may be modified by passing the rope round a pulley fixed to the

ground at a point between 200 and 300 feet in front of the glider, so that the car is driven in a direction approximately at right angles to the line of flight (see Fig. 28). Two or three short stakes should be driven into the ground

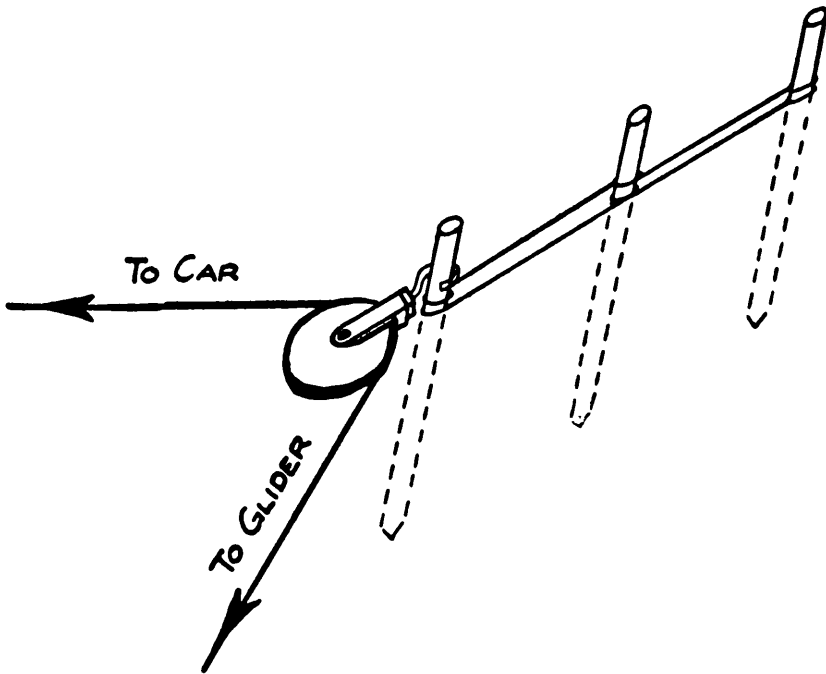

FIG. 29.—Pulley Fixture for Auto-Launching.

at, say, one foot apart, and should slope away from the bisector of the angle made by the rope, in the manner of a tent-peg; the stakes then being firmly tied together with cord (see Fig. 29).

A fair sized pulley with a large bearing area is required in order to keep wear to a minimum, and it should be kept well greased to prevent overheating, possible seizure, and wear.

A release mechanism fixed to the rear of the towing-car and operated by the driver or his assistant, as soon as the launching rope has been dropped clear from the glider, prevents the rope from being pulled further than necessary from the original position and the likelihood of the launching ring becoming jammed in the pulley.

As before, the number of strands of shock-cord may be increased up to six, for giving stronger launches, and the car may be started from a point a few yards behind the full rope-length position, so as to gain an initial speed while taking up the slack.

Winch-Launching.—This method of launching is rapidly displacing the earlier method of auto-towing, and in fact the potential developments attending winch-launching, both for school and club work, are certainly great. In its most usual form a large winding-drum is rigidly attached to one of the driving wheels

of the car, on to which the length of cable is wound. Cable lengths of 3,000 feet, or more, have been used.

From the drum the cable is passed through two pairs of strong rollers ; one pair being placed vertically, and the other horizontally, to allow for sideways and upwards deviation of the cable when in use. A pair of shears, forming a guillotine is incorporated at, or close to, the rollers for severing the cable in case of an emergency.

For preference the car should face the glider, so that the driver is able to keep the aircraft in full view, and in this case the rollers and shears may be attached to the front bumper of the car.

In operation the car is taken to the windward end of the field or site, the driving wheel is jacked up, whilst the other wheels are firmly chocked. The cable having been paid out and attached to the glider, the driver starts up the engine, releases the clutch and engages *top* gear. At a prearranged signal the clutch is let in, the glider commences to move forward and the engine is speeded up.

By keeping a careful watch on the climbing glider the driver is able to regulate the power accordingly. A piece of bunting tied near the end of the cable enables the release to be clearly noted, whereupon the winch driver lets out the accelerator and applies the brakes to prevent the cable being needlessly wound. An attendant should at all times stand by the shears in readiness to act as occasion arises.

If the power of the car is not sufficient to allow the launch to be made in top gear, the change should be made very near the start before the glider has left the ground, or when the machine is well in the air to avoid the possibility of causing a stalled take-off.

The chief disadvantage of this method of towing is that any alteration of the wind direction necessitates change of the car position, though this could be greatly simplified by the provision of a quick-action jack, preferably, attached to the car chassis. It will also be noticed that with winch towing the cable length steadily decreases, but this is not of great importance provided a sufficiently

long initial distance between car and glider can be obtained.

The great advantages attending this method are first that the nature of ground surface is unimportant provided a short length of level ground is available for the take-off run, whilst sloping and undulating ground may be used, and secondly the wear and tear of the motor vehicle is vastly less than with auto-towing and the driver is able to devote his whole attention to the progress of the aircraft.

There are several other methods of mechanical launching, but those already described have been found to be the simplest to operate, and the safest.

Aero-Towing.—Is used as a means of gaining height for the start of a sailing flight. The aeroplane may tow the sailplane to a region of up-winds, where the release is made, so that the sailplane may continue in sailing flight.

In this way cloud, storm, and thermal soaring may be engaged in from level country, or, if desired, the machine can be towed to a hill, or mountain side, where contour soaring is available.

Aero-towing is similar in many respects to auto-towing, but, owing to the higher speeds at which it is generally carried out, much greater loads can be produced on the sailplane, and for this reason the utmost care is necessary, and only those who understand the forces to which a towed craft can be subjected should undertake this method of flight.

Unless the towed sailplane has been specially designed for high speed, the aeroplane used for towing should be capable of flying at the comparatively low speed of the sailplane, and it should be borne in mind that the increased drag, due to the attached sailplane, will raise both the stalling speed and the taking-off speed of the aeroplane.

The towing craft should be fitted up with proper towing apparatus that is able to carry the loads transmitted by the connecting cable,¹ and there should be no possibility of the cable fouling the tail control units.

The cable should be of extra flexible steel wire rope, of strength equal to the loaded weight of the sailplane (5 cwt is suitable for

¹ See *Sailplanes—Their Design, Construction, and Pilotage*, by the same author.

most machines), or, alternatively, the cable may be stronger, but fitted with a 'weak link' at the sailplane end. The last mentioned arrangement is preferable.

A cable length of from 300 to 600 feet may be used, according to weather conditions. The shorter length is better, as it allows a faster climb, but for gusty or 'bumpy' weather it is advisable to use a greater length.

Quick releases should be fitted to both towed and towing craft.

In gliding, and soaring flight, the drag loads on the wings of a sailplane are negligible; but in towed flight they may be quite considerable, and for this reason the wings should be specially designed or strengthened to allow for this.

The greatest danger of aero-towing is present when the sailplane is high up above the aeroplane, in which case the sailplane carries a proportion of the latter's weight, and may in consequence be overstressed. This can be avoided by keeping the cable within an angle of 20° to the horizontal. On the other hand the sailplane pilot should keep clear of the slipstream area, and should not get below the towing craft.

For taking-off, the sailplane is set at the extreme edge of the aerodrome, on the leeward side, so as to allow as great a run as possible. Both machines move forward together, but the sailplane is quickly lifted into the air, where it should be held with the cable making an angle with the ground of roughly 15° , and this position relative to the aeroplane should be maintained throughout the flight, while attached.

The aeroplane pilot will find that his machine is slow in getting off, owing to the slower acceleration that is enforced by the extra drag of the glider. Some improvement may be effected by fitting wheels to the towed machine, although these may be dropped after the launch if desired.

The climb should not be of too rapid a nature and all turns should be made over a large radius. Jerking of the cable must be carefully avoided by both pilots, as it may well spell disaster.

Should the pilot of the sailplane find he is too far above the aeroplane, he should not try to lose height by diving directly forwards,



THE "SCUD II."

since this merely increases his speed, and thus causes the cable to become slack, and must consequently be followed by another climb. Height may be lost by following a gentle zig-zag course, so that the path is made longer than that of the front machine, and by slightly depressing the nose at the same time.

CHAPTER XI

MATERIALS OF CONSTRUCTION

Timber—General.—All timber used in glider construction should be of aircraft quality, properly seasoned, free from knots and splits, or shakes, and of straight grain. The moisture content is also a factor of importance, and should be between 14 and 16 per cent. Unless means for testing for strength and moisture content are available, it is recommended that the timber should be purchased from an aircraft firm, or from a timber merchant who understands the requirements for aircraft work.

Silver Spruce.—The most suitable timber for aircraft construction is silver spruce. It should have a crushing stress (minimum) of 5,000 lb per sq inch. The elastic limit figures are 4,000 and 10,000 lb per sq inch in compression and tension.

Straightness of grain should not be coarser

than 1 in 15, and moisture content should be 15 per cent.

Ash.—Skids and parts that are to be bent before use, such as wing tip members, curved forward parts of longerons, etc., should be made of ash.

The strength figures for this material should be at least as good as those for spruce, but with a straightness figure of 1 in 10. Where hard blocks, and parts subjected to wear are required these also should be of ash.

Plywood.—Plywood is extensively used in glider and sailplane construction, and in many cases the plywood is relied upon for resisting the main flight loads. For instance, the plywood over the leading-edge may be solely responsible for withstanding the heavy torsional loads that fall on a wing in certain conditions of flight; the lift strut fairings are generally relied upon to resist collapse of the strut; the fuselage covering may take all, or most, of the loads transmitted from the tail unit; whilst plywood webs in spars, ribs, etc., are stressed components of the main structure.

It is thus seen that only good quality plywood should be employed for such parts. Ordinary commercial ply is not suitable, since the gluing may not be sufficiently even and joints in the centre ply may be too closely spaced.

A shear strength of 200 lb per sq inch over the glued face is called for, and may be easily determined by cutting a strip of 1 inch width, across which saw cuts through the outer plies are made on opposite faces and 1 inch apart. A weight of 200 lb may then be suspended at one end.

Plywood is manufactured from birch, mahogany, and teak, the plies being cemented together under pressure. The centre ply generally has the grain at right angles to the outer plies, but it is important that plywood used for the control surface levers should have all plies parallel.

Steel.—The usual practice is to make fittings of mild steel sheet (Specification 2.S.3), having a strength of 28 tons per sq inch; mild steel bar (Specification 3.S.1) of 35 tons strength, and mild steel tube (Specification T.6) of

30 tons per sq inch. These steels are easily worked and welded, and are therefore popular.

By using high-tensile or non-corrodible steels a considerably saving of weight is possible, but both the initial cost and the cost of working are much greater.

Aircraft fittings that have been made by bending or welding should be heat treated before use in order to eliminate the internal stresses set up during working. This process consists of heating the fittings to the normalizing temperature for the material, and allowing to cool in air. Temperatures vary for different material specifications but for mild steel 860° C. is correct.

Aluminium.—Aluminium is not much used for glider construction, except occasionally for the nose of a fuselage, and unstressed fittings. It is obtainable in hard and soft grades, the latter being most suitable for this type of work.

Duralumin.—This light alloy of aluminium is used to some extent for stressed parts on account of its lightness. It has a strength figure of 25 tons per sq inch, or nearly that of mild steel, but is roughly six times as

expensive and being soft, is rather liable to damage. Also it is welded only with difficulty.

Cement and Glue.—Cement, or cold water glue, is mostly used for glider construction as it is simple to use. It is obtained in powder form, and is mixed with an equal quantity of water. It is important that it should be well stirred, and this can be done by means of a geared hand drill, or brace, with a piece of wire, bent over or coiled at its lower end, inserted.

Cold water glue is ready for use in ten minutes after mixing, but should be used only on the day of mixing, so that sufficient for the day's work only should be made.

This cement should be applied to both surfaces to be joined, and allowed to become tacky. The glued parts should be clamped together with cramps, and left for about 16 hours. The correct pressure is about 200 lb per sq inch, and the spacing of the cramps should depend to some extent on the area being glued.

Gelatine glue, or hot water glue, should be applied hot, in a room temperature of not less than 70° F., and kept in the glue room for sufficient time to prevent chilling.

Overheating and re-heating are detrimental to the strength of gelatine glue.

Fabric.—Woven Irish linen with close mesh, is the most suitable covering material. Ordinary aeroplane fabric weighs 4 oz per sq yard, but a special light fabric, called glider cloth, is available at half the normal weight. Egyptian cotton may be used in place of linen, but is not as satisfactory.

Dope.—The purpose of dope is to render the fabric airproof and waterproof, to give tightness, and to provide a smooth finish. Dopes are either acetate, or nitrate, the latter being cheaper, less affected by atmospheric conditions, and has better tightening qualities. Acetate dope is better known in power aircraft work, since it is less inflammable, but this is of little importance in glider work.

Transparent dope is generally used for sailplanes, since it lends a smoother finish than aluminium dope. It should be applied at a temperature of between 60° and 70° F. Below 60° F. the dope tends to 'curdle'.

Three, or four, coats of dope are recommended, and each coat should be thoroughly

dry before the next is applied. The first coat should be well brushed into the fabric to ensure proper adhesion and should be laid on in sections. One gallon covers about 8 square yards of fabric.

Special dope has recently been introduced for use in almost all temperatures, particularly the lower winter temperatures, but the best results are obtainable under heated conditions.

The dope should be well stirred before use, and at frequent intervals.

Varnish and Enamel.—Varnish is used to provide a finish and to make more weather-proof; one coat generally being considered sufficient. Varnish consists of gums or resins, dissolved in oil or alcohol. The former is more elastic and durable, and is therefore preferable for all exposed parts, such as wing coverings, of plywood or fabric, fuselages, etc.

Extra smooth and polished surfaces can be obtained by the application of two or three coats of varnish, each undercoat being rubbed down with pumice powder and water before applying the next. The additional weight of

extra coats of varnish is roughly 1 oz per sq yard of surface for each coat.

Metal fittings should be protected from weather with enamel or varnish.

The internal structure of wings, fuselages, etc., should receive a protective coating of varnish, or shellac, as this treatment preserves the timber and lengthens its life considerably.

Brads.—In the most usual method of glider construction, particularly for performance machines, no brads are left in the finished parts. In this case the brads used during construction may be of steel, when a magnetized hammer may be used, and this considerably facilitates the work. If steel brads are allowed to remain in the wooden structure, corrosion is bound to set in, with the inevitable result that the timber qualities quickly depreciate. Brass brads should be employed if they are to be left in position.

Wires and Cables.—Piano wire is used almost exclusively for the anti-lift wires of training gliders, and for the drag wires of all types. This is high-tensile steel wire with a breaking stress of 80 tons per sq inch, though

only 65 per cent strength is allowed for, on account of the end fixings. Piano wire is likely to suffer from fatigue after use over a period. The wires are subjected to loads of varying intensity in use, are often distorted by handling, and are attacked by corrosion. For these reasons the wires are liable to fail from fatigue under comparatively small tensile loads.

Coating of all wires with some protective material and careful maintenance prolong the life of these wires ; but it is strongly recommended that they should be renewed every twelve months, or so.

The use of piano wire for lift wires has been discontinued, and substituted by cable.

Cables used purely for taking tensile loads, such as drag cables, may be made from 'straining cord', consisting of 7, 19, or 37 wires wound together, for strengths up to 10, 25 and 135 cwt respectively.

For control cables which pass over pulleys, 'extra-flexible' cable should always be employed. 5 cwt 'extra-flexible' cable is made up of 4 or 7 strands, each containing 7 wires, and 10 cwt rope of 7 strands of 14 wires each.

Continual bending over small radii, such as when in use over a small diameter pulley, causes rapid depreciation of the cable, and is very liable to cause fraying. Frequent inspections should be carried out.

For auto- and aero-towing, a kite-balloon cable, containing a central core of rope or telephone cable, is recommended.

CHAPTER XII

THE CONSTRUCTION OF GLIDERS AND SAILPLANES

I. WING CONSTRUCTION

Spars.—The spars of elementary training gliders are usually made solid, and of rectangular section, for cheapness (Fig. 30(a)). Their manufacture is consequently simple,

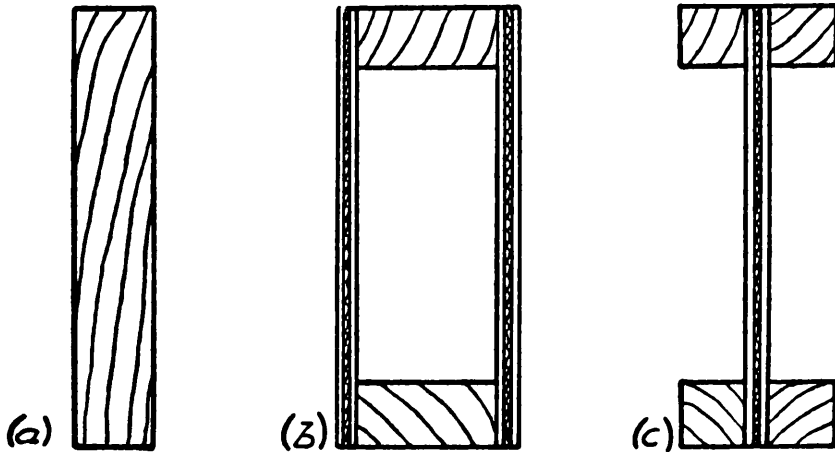

FIG. 30.—Spar Types.

being only a matter of sawing and planing. A straight grained plank of the required size is planed evenly to the correct width, when the top and bottom faces are marked out and planed

to size also. The root end may then be cut square and the tip cut to the required length and shape.

For other machines the spars are generally of either 'box', or 'I' section (Fig. 30 (b) and (c)). If the section is rectangular, the spar shape in elevation can be drawn out full size on a bench or floor, or directly on to the plywood sheets to be used for the web or webs. The various lengths may then be cut to size, and the edges carefully planed. The flanges, of rectangular cross-section, are also cut and planed to shape, glued in position, and clamped along the entire length. A better job can be obtained by leaving both the web and flanges rather deep and planing the top and bottom faces to marked lines on the sides, after the glue is set. This procedure also holds good for spars in which the top and bottom faces are not parallel, *i.e.* are sloped to conform with the wing profile.

When squaring off the root ends of spars this should be done at the angle of dihedral, if any. Proper allowance should be also made for sweep-back, or sweep-forward, of the spars.

Where it is necessary to make joints in the plywood webs, the faces to be joined should be well 'feathered', the length of joint being 15 times the web thickness, and thus giving a splice angle of 1 in 15. (See Fig. 31.)

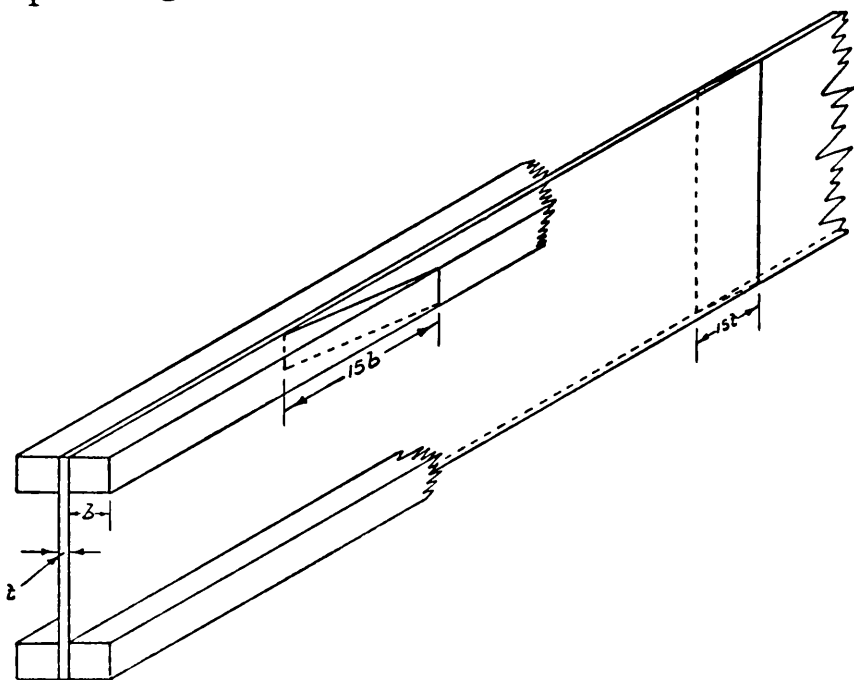

FIG. 31.—Splices in Spar.

This applies also to flange splicing where necessary, as is shown in Fig. 31. Care should be taken to see that the position of splices is as shown on the drawings, if specified, and joints in flanges and webs should be kept well apart, or a weak spot will result.

Where spars are blocked, the blocks should be cut with the grain running lengthwise, that is parallel to the length of the spar. They should be glued to the flanges, under pressure, before the webs are attached.

Small holes should be drilled in the web, at half depth, in box spars, to allow for the escape of moisture after gluing. There should be one hole between each pair of internal blocks.

Ribs.—There are two main types of ribs used in glider construction ; one in which the flanges and cross struts are held together with external plywood gussets at all joints, and the other is the split type in which flanges and cross-struts are divided down the middle, the halves being separated by internal gussets (Fig. 32 (a) and (b)). It is not essential for the gussets in the former type to be placed on both sides of the rib, although it is quite often done, as it gives greater strength for very little extra weight, and expense.

Ribs should be made up in a jig, after all the parts have been cut to correct size. The rib may first be drawn out to full scale on a thick board, from which the lengths of flanges and

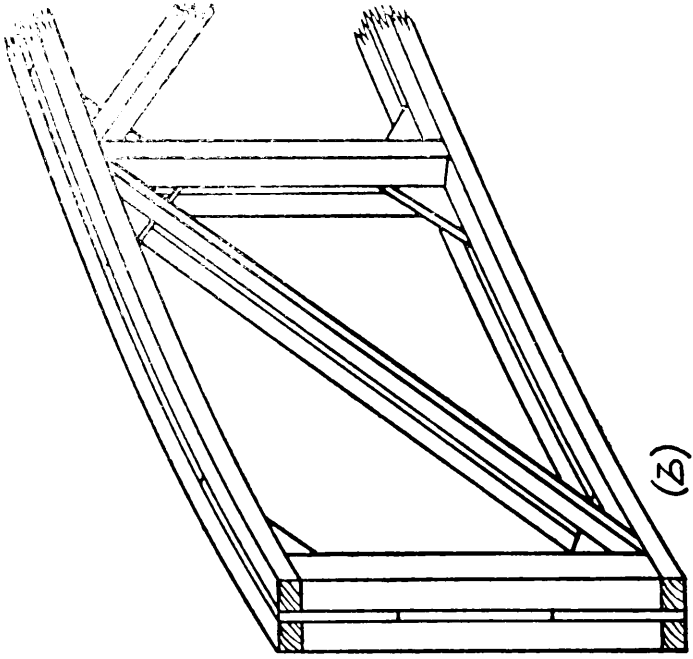
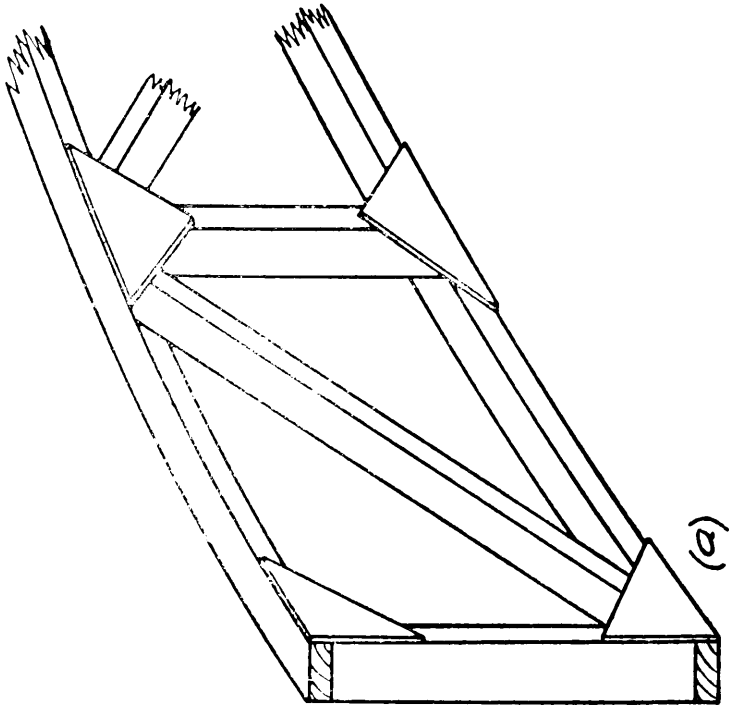

FIG. 32.—Rib Types.

cross-struts can be obtained, and then sufficient parts for the complete wing may be got ready. If the rib noses are to include plywood webs, these may be sawn out with the aid of a fret-saw in half-dozen lots.

The marking-out board, already referred to, can be made to serve for the jig also by screwing or gluing, small wooden blocks round the outside of the flanges, as shown in Fig. 33, and trimming the edges of the board beyond

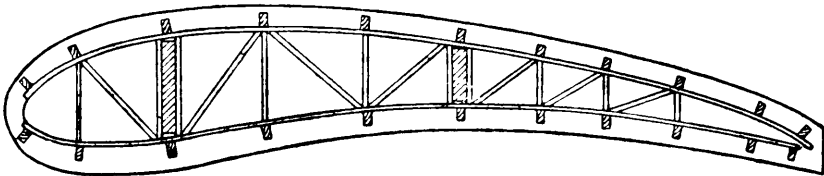

FIG. 33.—Rib Jig.

the blocks. Short lengths of spar section are also fixed in position at the spar centres. Some arrangement must be made for holding the rib together under pressure after gluing and this may be done by cutting a board to rib shape which is then placed on the rib, between the blocks.

The whole may then be clamped together by about a dozen cramps, or, alternatively, holes

may be drilled vertically through the jig board, and the rib-shaped board, through which bolts are inserted, and tightened in position with nuts. It will be noticed that three or four ribs may be made up at the same time by this method, provided the jig blocks are made sufficiently deep.

When making up a rib the gusset pieces are glued and placed in position on the jig: the cross members are then placed in position and the flanges, or booms, are then inserted. The upper faces of the joints are then finished off by applying the second set of gussets. In the case of split type ribs, one half is first laid in the jig, then the gussets, glued on both sides, and finally the second half of all members.

Wing Assembly.—In building up the wing, the main spars should be set up on two or three trestles, on which the spar positions have been previously marked. If the spars taper in depth, or are to be set at a dihedral angle, blocks should be fixed to the tops of the trestles so that the spars rest in their true relative positions for height, distance apart, etc. The trestles may be temporarily fixed to the floor

when their positions have been properly determined.

The spars, with all rib spacings marked on them, are then placed on the trestles and the ribs slipped into position, glued, and clamped.

Leading and trailing-edge members are next attached, followed by the diagonal, or drag, bracing. All metal fittings may then be attached, and all bolts properly locked or secured.

If plywood is employed over the forward part of the wing, the spaces between the ribs on the spar top and bottom should be filled in with small wooden strips, of depth equal to that of the rib flanges. One edge of the plywood may then be laid on the top glued surface of the spar and held temporarily by means of a strip of wood tacked on the outside. All rib flanges and the lower spar surface are also glued and the ply sheet is pressed down over the top surface round the leading-edge and back to the spar undersurface, where it may be fixed again with an external strip, and tacks. Pressure may be obtained by placing a number of wooden strips, spaced every 2 inches,

longitudinally over the ply nosing and binding tightly with cord. The cord is passed up behind the spar, over the top, round the leading edge, and back to the spar, care being taken to avoid damage to the spar by placing similar wood strips along the back face of the spar.

If the plywood is thick, and can only be bent to shape with difficulty, it should be laid out on the floor and wetted on the top face. After some minutes the ply may be attached with the damped surface on the outside.

The aileron can best be built up with the main plane, by keeping the ribs continuous, but by inserting the aileron spar at its correct distance behind the main plane spar attachment. After completion of the whole framework, the aileron can be separated by cutting through the rib flanges and trimming the ends.

Fabric Attachment.—There should be as few seams in the fabric as can be arranged for. The type of seam is shown illustrated in Fig. 34 in which about $\frac{5}{8}$ in of each edge is folded under and stitched with a double row, the pitch of the stitches being roughly nine to the inch.

The upper forward edge of the fabric may be glued to the top surface of the front spar, and rubbed down well with the fingers, until it is set firmly. Then the rib flanges, remaining spar faces, and trailing-edge member may be glued on the outer faces, and the fabric stretched over the top surface, round the trailing-edge, and back to the front spar. It should be rubbed well on to all members in contact.

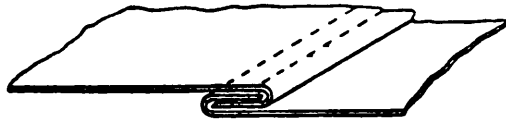

FIG. 34.—Fabric Seam.

Dope is sometimes used in place of glue as adhesive material.

Where the undersurface of the ribs is concave the fabric should be stitched to prevent it coming away. The thread should be waxed to prevent slackening, and the pitch of stitches made from one to two inches, knotted every few stitches so that the fabric will not come right away in the event of the thread breaking at one point.

The wings of primary gliders, and of some

secondary machines, are entirely fabric covered. In such cases the fabric sheet may be laid out on the floor, and the wing placed on the top, with the trailing-edge close to one edge of the sheet. The fabric is then folded back over the leading-edge, trimmed, and stitched along the trailing-edge, root, and wing tip.

It may then be stitched at intervals of six or eight inches and doped in the ordinary way. For notes on doping, refer to the chapter on "Materials of Construction".

II. FUSELAGE CONSTRUCTION

Girder Type Fuselage for Elementary Glider.—

This is built up in a somewhat similar way to that described for ribs. The exact shape is drawn out on the floor, and all members cut to size. Wooden blocks to form a jig may be fixed along the inside and outside of the boom and strut positions, between which the prepared parts are laid. Plywood gussets are then glued and placed in position at the joints, and held tightly by means of brads. The ply sheeting on the side of the keel is likewise fitted. The framework is carefully lifted, and

laid down on the finished face, so that the other side can be completed.

The curved bottom member should be of ash, and may be steamed to shape beforehand.

The stiffening members running along the sides of the keel are drilled, glued, and bolted in position, after which the ash skid, control system, rudder bar, seat, and all fittings may be attached. Triangular wooden blocks, at the junction of two members, should have the grain parallel to the outer face, if the angle is greater than 90° and perpendicular if less than 90° .

Monocoque, and Box Type Fuselages.—The complete set of frames should be made up first. Each frame should be drawn out on a bench, or board, with wood blocks, or headless nails, to complete the jig. For rectangular and hexagonal sectioned fuselages the jig blocks may be fixed in the longeron positions ((a) Fig. 35); but, for oval sections a large number of blocks is needed, as illustrated at (b). Members of considerable curvature should be made of ash, and, unless quite thin, should be built up of laminations. Alternatively, a

number of short straight lengths may be employed, and cut to the correct shape after the plywood faces are fixed.

Fig. 35 (b) shows the jig blocks for one half of a frame, with the plywood web shown dotted in the other half.

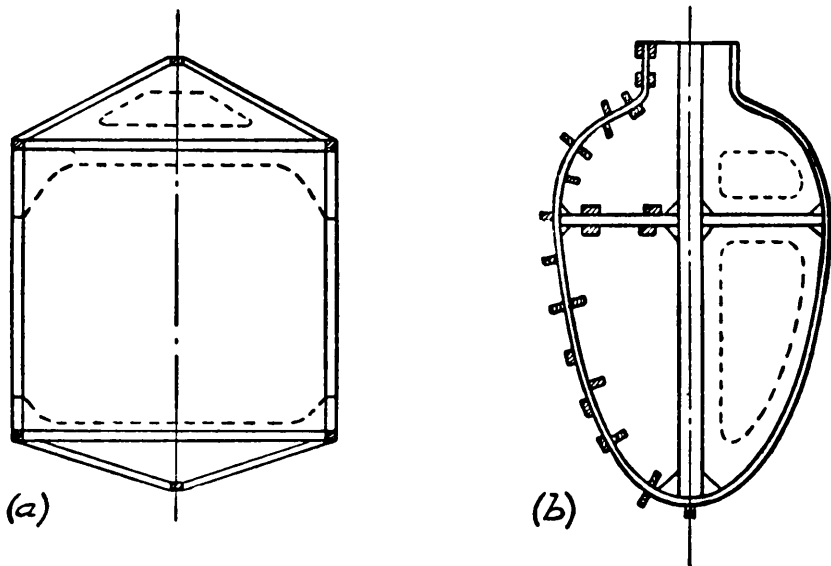

FIG. 35.—Construction of Fuselage Frames.

Fuselages are generally constructed in the inverted position, in a building jig or framework, with the side longitudinal members resting on, and clamped to, fixed transverse frames (Fig. 36). The front faces of the jig frames are spaced identically with the fuselage

frame spacings, and are made to heights above a horizontal datum line corresponding to the shape of the side longitudinals in side elevation. The plan shape of the fuselage longitudinals is drawn on the transverse pieces of the jig frames, by first setting out a centre line through the whole length of the framework, and marking out half the fuselage frame

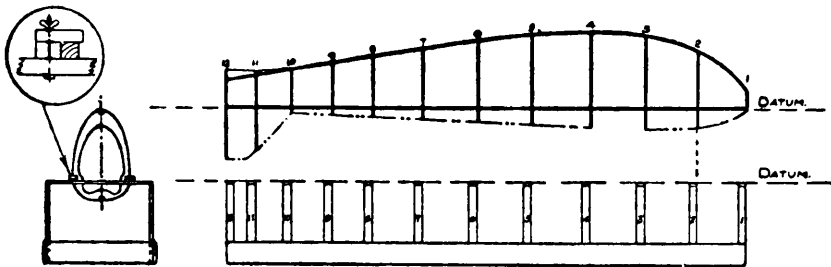

FIG. 36.—Fuselage Construction.

width at each section on either side. Small blocks, of depth equal to the longeron depth, are fixed on the outside of these lines, on the top of which, and protruding inwards, are clamping pieces, which are rotatable on screws, or which are held in position by butterfly nuts.

The two side longerons, which should have been previously shaped, are clamped in position first, after which the transverse frames are placed in position on the longerons, close

up to the frame cross members, and rigidly attached. The bottom longitudinal (top in inverted constructional position), or keel member, is also fixed.

The plywood sides are then attached in lengths equal to one, two, or more frame spacings, as convenient, each joint being at a frame position. The plywood joints are well scarfed, or feathered, as explained earlier in this chapter. Each sheet should be glued, and clamped in position, and allowed to dry before the adjacent sheet is fixed.

Finally the fuselage may be removed from the building jig, by undoing the clamps, turned over, and completed. Before finishing off the top of the body it is well to affix all controls, fittings, seat, elevator attachment fittings, and control cables.

An alternative constructional method consists of making a large internal, vertical jig, around which the fuselage framework may be built up, and which can be taken to pieces afterwards for withdrawal.

Control Surfaces.—The method of construction for the spars of aileron, tail plane, elevator, and

rudder follows that described for the main planes. Reference has already been made to the method by which the aileron is built as one unit with the main plane, and this may be applied also to the tail plane and elevator.

In some cases, diagonal strips of spruce are run from one rib root to the trailing edge at the next, to give torsional stiffness to the whole. These should be wetted before fixing so as to ensure tautness when dry. It is difficult otherwise to obtain a sound, tight job. Similar strips are sometimes used for the internal drag bracing of main planes, and these should be treated in the same manner.

The control levers, if of plywood, should be made of aircraft quality multiply, with the grain of the outer faces parallel to the length of the lever. A special veneered sheet, in which the grain of the veneer faces runs parallel to the thick central core, is recommended for this purpose, and should, of course, be used with the grain running the length of the lever. Copper eyelets must be inserted in the cable attachment holes. The copper tubes used for the purpose should project by about $\frac{1}{16}$ inch

each side, and this part should be belled out with a conical faced punch.

Metal Fittings.—All bends of fittings should be properly made over a bending bar with a rounded edge; the radius of curvature being equal to the radius called for on the fitting. The radius should never be less than the gauge thickness, although a good standard to work to throughout is twice the gauge thickness. If the bends are made over a bending bar with a sharp edge, the fitting will not be true to scale, and, of greater importance, the material at the bends will be overstressed, and very liable to the development of cracks.

Finished fittings should be heat treated to remove the internal stresses induced during working.

All holes should be correctly drilled to the correct size, with proper tolerances as specified in Appendix II, p. 241. A case-hardened drilling jig, in which the holes have been correctly drilled, is advised if more than one of any fitting is to be made, and where bolts are to go through two parts of a fitting, such as spar root end fittings, great care should be taken to ensure that both

parts are drilled identically. No less care should be taken over holes drilled through timber, since in most cases the bearing stress of the bolt on the timber has been carefully calculated. A loose or bad fit would not provide the bearing resistance allowed for in the strength calculations. Wiring lugs should be accurately aligned with the wire or cable attached.

Welding.—Is a process of making joints in metal by bringing the two parts to their fusion temperature, and filling the joint with cast iron. The heat is generally supplied by means of an oxy-acetylene flame, and great care is necessary for getting the correct degree of heat. Unless the constructor is familiar with the process, and has had considerable practice, welding of aircraft fittings should be left to the specialist.

Butt joints are weldable, but much better results may be obtained by chamfering the two edges to be united so as to make a 'V' angle of 45° . The metal forming the two sides of the joint, together with the welding rod, are brought to the temperature of fusion, the flame and rod being moved along at such a

speed that fusion temperature is just reached, but not greatly exceeded, or burning of the metal results. The welding rod, or wire, is held just in front, or just behind, the flame, and one or the other, preferably the wire, is oscillated from side to side which gives the resulting surface the appearance of a continuous series of overlapping circles. Over heating causes burning of the metal, and results in uneven disposition of the fusing iron, whilst insufficient heat also gives an untidy appearance.

Imperfectly welded joints are not always easy to detect, although one simple test may be made by applying petrol to one side of the weld, when it will soak through to the other side where the joint is not complete.

Welded joints in mild steel, when well made, give about 90 per cent of the original strength. The weakest part of a weld is about $\frac{1}{2}$ inch to either side. Fittings which take heavy loads should not be welded, unless the welded position is not a highly stressed part. All welded parts should be normalized, by heating to 860° C. and allowing to cool in air, to remove the stresses caused during the welding

operation. Heat treatment is not essential with mild steel, Specification 2.S.3, but the full strength is not developed in this case.

Cable Joints.—The ends of cables have to be provided with eyes. This is done by bending the cable round a brass, heart-shaped thimble and allowing about 8 inches for splicing. The splice is the ordinary seaman's splice which is accomplished by forcing open the strands by means of a marlinspike, and tucking the strand ends through and back in such a manner that load on the cable binds the strands tightly together. The joint between the thimble and cable may be bound with waxed thread for keeping out dampness.

Miscellaneous.—Pulleys should be correctly aligned with the direction in which the cable enters and leaves, and should be fitted with guards to prevent the cable from slipping or jumping free. Large pulleys are preferable, and inspection holes should be supplied for purposes of lubrication and inspection.

Bolts should be of correct length, and should not be threaded to a greater depth on the shank than necessary. The threaded part of

the bolt should never bear on the fitting or timber.

Large diameter washers should be inserted between timber and bolt heads or nuts, and all bolts should be permanently locked by burring the end, or by centre punching the thread between the nut and bolt, in at least three places, or by the employment of castellated nuts with split pins, or safety pins, or other lock nuts. Where two nuts are used to provide the locking, the lower nut should be well tightened before screwing up the second.

Bolts tend to loosen after they have been in timber for some time, due to shrinkage of the latter, particularly in hot weather, and it is well to check all nuts before covering with fabric or plywood.

Appendix I on p. 237, gives the B.G.A. inspection questionnaire for construction, and this contains a number of important points which should be given consideration during the building of a glider.

CHAPTER XIII

MAINTENANCE AND REPAIRS

General.—No attempt is made here to cover the work entailed in major repairs, such as rebuilding a wing, or fuselage, as this is covered in the chapter dealing with construction. Such work is not beyond the capabilities of amateurs equipped with a little knowledge of carpentry, especially when an experienced person is available for supervision.

The smaller repairs, usually resulting from heavy landings, are easily effected, and should always be undertaken by the team using the damaged machine, so that flying can be recommenced with the least possible delay. If this is done the pupils will gain a good knowledge of aircraft structures, besides which crashes will not be regarded as such calamities as they would otherwise.

Furthermore, when the pupils know that they are to fly the machines after repair, they

will learn to do careful work and to take pride in their structural achievements.

Heavy Landings.—Training should always be suspended after a faulty landing has been made, even though the machine is apparently quite intact, whilst an examination is made for possible distortion or damage. It often happens that one member of the team makes a bad landing, which perhaps strains a wire, and thus alters the incidence of one wing. He is followed by the next pupil who finds control awkward, turns out of wind, crashes, and consequently is wrongly blamed for the resulting damage.

The examination often reveals that the flying wires are very slack, and one's first impulse may be to tighten them. This should not be done, as it is *the anti-lift, or landing wires that are stressed in landing*. Sometimes one and sometimes both wings are affected, and this should be ascertained before any adjustment is made.

To do this, the fuselage should first be held up in its vertical position. Then stand in front, some few paces forward of the nose, when the

eye should be able to detect which wing droops, and the turnbuckles above the drooping wing, or wings, should be unlocked. One member should be stationed at each wing tip to support the wings while the turnbuckles are screwed up. The complete wing should be checked by the procedure described in Chapter IV, under '*Truing-up*'.

The instructor should make a test flight after all repairs and adjustments to ascertain that the flying qualities are as they should be. Any tendency on the part of the machine to turn to one side will generally be found due to wrong rigging for incidence, or incorrect setting of the ailerons.

The first flight of the day should also be undertaken by the instructor, and occasional flights during the day. These flights are often regarded as a waste of time, but they may be the means of preventing a crash, and at the same time demonstrate to the pupils how their flights should be made.

Replacing a Wire.—It sometimes becomes necessary to replace a wire. This may be the result of continual stretching so that no more

adjustment is available, or the wire may have snapped during a landing.

Support both wing tips by trestles, or by members of the team, and cut out the broken or strained wire. If the fitting to which the wire attaches can be easily removed from the machine, this should be done as it facilitates the work. It is generally only necessary to take out one part of the wire, but this should be the longer portion, as the stretch is likely to be in this part. Obtain a new length of wire, of the same gauge and strength specification, and on to it thread one wire ferrule, and with a pair of bull-nosed or round-jawed pliers make a loop three or four inches from the end, so that the turned back portion is parallel to, and close along, the main wire. Engage the fitting to which the wire is to be attached, slip the ferrule over the double portion as close to the loop as can be managed, turn back the end so as to hold the ferrule in position and then cut off the surplus length (see Fig. 37). Care should be taken to obtain a well shaped loop and to avoid damaging the wire in any way, as slight damage may lead to

fracture. If the wire is cut two or three inches longer than required, it facilitates the bending up, and thus avoids bruising the wire. Moreover, if an attempt is made to cut to the exact length initially, there may be a shortage after making the loop.

Now measure off the length of wire against the discarded length, allowing sufficient for the end, but deducting half an inch or so to allow for the stretch in the old wire, thread on



Fig. 37.

a second ferrule and complete the eye as before, remembering to place the turnbuckle eye in position when the loop has been made.

After the wire has been replaced the wing should be trued up again as previously described. It may be found that the wire slackens somewhat after a few flights due to the end loops pulling up, in which case a further adjustment must be made.

Spar Repairs.—Generally speaking a damaged

spar constitutes a major repair, and since the main spars form such an important part of the load carrying structure, the greatest care is required in this repair.

It is of the utmost importance that the strength of a spar after repairs should be at least as high as that of the original spar at that point, and it may be well to point out that *the spar, more than any other member, depends not so much on the amount of material used in its construction, but in its disposition*, and therefore unless someone is present who understands the nature of the stresses that are set up under all conditions, and the strength of structural members, it is far better for amateurs to leave such work to a competent craftsman.

It will be noticed that when a spar gets damaged a crack usually occurs at the outside edge, as at (a) Fig. 38. The crack is prevented to a certain extent from developing by the grain of the wood, although, unless repaired immediately, it tends to spread, more or less along the grain, as at (b), till complete fracture takes place.

The repairing material is required at or near

the outside edge, also, and for this reason an extra strip is sometimes glued along the top or bottom of the spar so as to be flush with the covering fabric. Owing to the small space

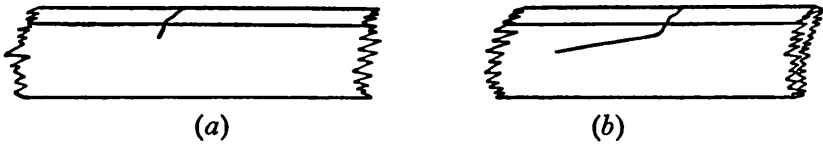

FIG. 38.—Spar Fracture.

available for such a strip, this method can only be employed for small fractures.

The alternative is to fasten plates on both sides of the spar, as shown in Fig. 39. These may be of plywood or spruce, and their combined thickness should at least equal that of

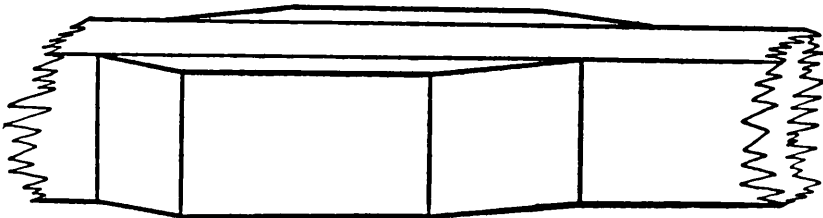

FIG. 39.—Spar Flange Repair.

the spar. These plates should extend several inches beyond the limits of the crack, and should be feathered, or tapered in thickness, towards the ends, as otherwise a weak spot

will be formed owing to the sudden change in width of section.

The plates should be glued with cold water cement, and held in position under pressure, by means of cramps, for at least 24 hours. A few brass brads may be used to hold the plates in position if desired.

The usual position for such fractures to take place is at the point of attachment of the wires to the main plane, and they can be detected by holding the wing tip, and moving it up and down. If there is any doubt the fabric at this point should be opened up sufficiently for an examination to be made.

When the fracture is in close proximity to the wire attachment fittings, it may be necessary to remove the fittings in order to get the stiffening plates into position. If the fittings have to be replaced over the plates a new end strap for the wire may have to be made to allow for the greater width of spar.

Spars of box section, or of a section as illustrated in Fig. 40, in which one of the flanges is damaged (the flanges are the top and bottom members of a spar, whilst the vertical

member, or members, are called webs) can be stiffened up by adding a strip along the top of the flange, as previously mentioned, or the strip can be glued to the web on the outside

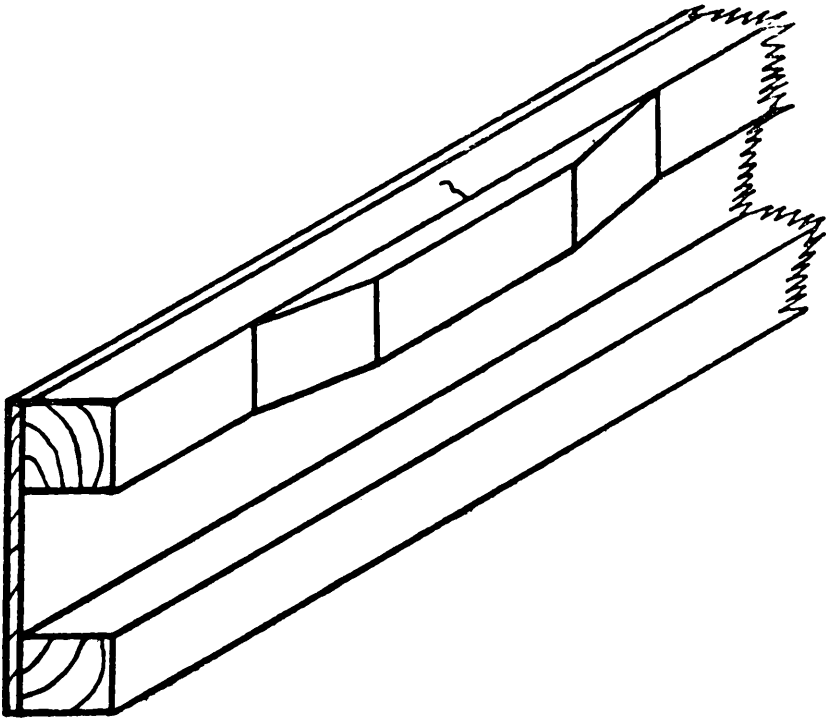

FIG. 40.—Spar Repair.

(see Fig. 40). In all cases the added strips should taper towards the ends. Damaged webs can be repaired by gluing on plywood plates as explained for simple spars.

Repairs to Ribs.—One of the commonest forms of damage to gliders consists of broken ribs, but fortunately they are easily repaired. If the rib is badly smashed it is often quicker, and better, to take out the rib, and build up a complete new one in its place.

Remove the broken rib as carefully as possible, so that little further damage is done, and lay out the pieces on a board or bench. Where the wing section is known this can first be drawn out on the board, but failing this the shape must be estimated as accurately as can be managed with the aid of the old parts. In some cases an undamaged rib may be cut out for this purpose.

Obtain a number of small wooden blocks, and glue or screw them round the outside of the section, and on either side of all cross pieces. This is shown in Fig. 33.

A temporary jig, suitable for making one or two ribs only, can be made by using headless nails in place of the wood blocks.

Now cut the new strips for the booms, or formers, and cross struts, and place them in position in the jig.

The rib must not be completed, or it will be impossible to insert it in the wing, and for this reason the bottom boom should be left loose. Small plywood plates should be attached at all joints in the rib, on one or both sides, but these should be left off the bottom joints.

When the glue is set the rib can be removed from the jig, taking reasonable care to retain

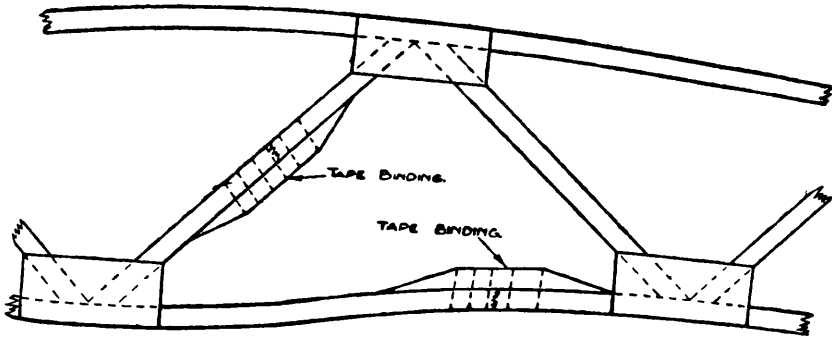

FIG. 41.—Repairs to Rib.

its correct shape. Slip the rib (less the bottom boom) over the spars and clamp the bottom boom in position. Glue the bottom plywood plates where required and fix with cramps.

Where the damage is only slight ; say, for instance, one or two cross struts and one boom are fractured ; the repair can be effected as follows. The cross struts may be taken out

and replaced, or a small piece of spruce, of section similar to that of the strut, cut with tapered ends, can be glued to the broken strut, and bound with tape. The boom can be treated in exactly the same way. See Fig. 41.

Drag Bracing System.—When a wing is opened up for repair, or any other purpose, it is well to make a cursory examination of all the internal members. Sometimes it will be found that the diagonal bracing needs attention.

Wire bracings may be tightened up by means of the turnbuckles provided, but they must not be overtightened. The more usual type of drag bracing consists of spruce-cum-plywood struts, somewhat resembling spars in construction.

Where these are damaged they can be repaired in the manner explained for ribs and spars. If the ends have come loose, they should be cleaned, reglued, and fastened in cramps.

The condition of the drag bracing system can sometimes be ascertained, without opening up the wing, by holding the wing tip with both hands, and exerting a twisting force. If the

fabric tends to crinkle unduly the fabric should be opened up for a better examination to be made.

Fabric Repairs.—Where fabric has been torn, or cut open for internal examination, the repair should be made by herring-bone stitching with waxed thread, the thread being passed alternately over and under the fabric edges, as shown in Fig. 42, as this keeps the two edges

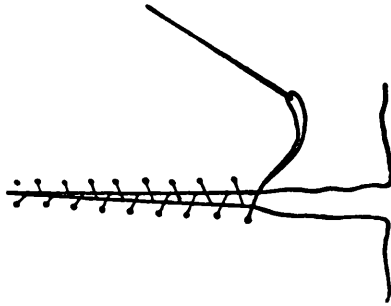

FIG. 42.—Fabric Repair.

close together and prevents them from sagging from the surface. The thread, which should be used double, should be knotted every few inches so as to prevent the whole repair from coming apart in the event of the thread giving way at any one point.

The stitching should be kept at least $\frac{1}{4}$ inch from the edge of the fabric to prevent pulling through.

When the stitching is completed a strip of linen tape, about two inches wide, should be placed over the repair and doped into position. For training machines the linen tape may have the edges frayed or serrated to a depth of $\frac{1}{4}$ inch, as this helps it to adhere to the fabric;

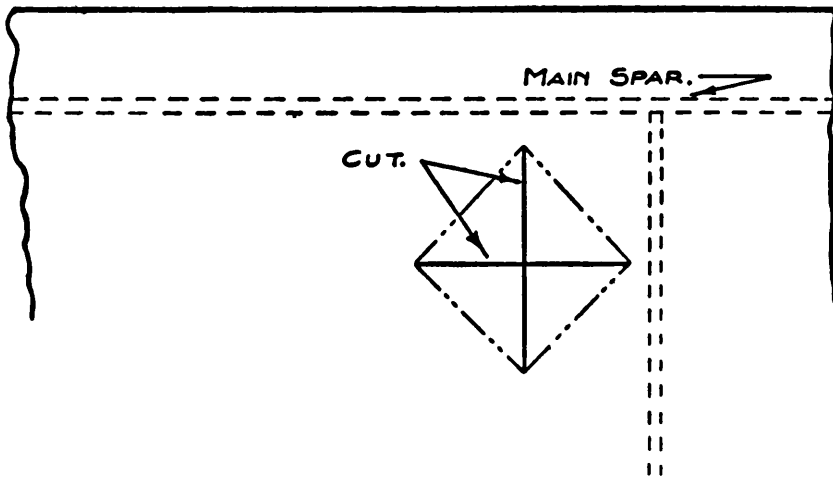

FIG. 43.—Opening up Fabric for Wing Repair.

but for high efficiency sailplanes it is better to keep the edges unfrayed on account of frictional air resistance. Special cutters for serrating fabric are now obtainable.

In cutting open a wing for local examination or repair, two cuts should be made in cruciform shape, as shown in Fig. 43. This enables the

largest opening for a given length of cut to be obtained, gives easy access to fittings, etc., and keeps the stitching well clear of main spars and other members.

In some cases it is necessary to renew a large piece of fabric. The new length should first be sewn to the edge of the remaining fabric with the type of seam shown in Fig. 34, p. 199. The new fabric is then stretched tightly over the surface to be covered and may be temporarily tacked into position. It can then be stuck down in turn to the leading-edge, and plywood covering, the rib flanges, the wing tip, and trailing edge, and sewn where necessary. The adhesive material, which is applied to the wooden members, should be glue for preference, though dope is often used. The fabric parts touching the glued faces of spar, ribs, etc., should be well rubbed down with the fingers.

For completely renewing the fabric of a wing, or control surface, refer to the chapter on construction.

Fuselage Strut and Longerons Repairs—Splices.—Fractures in struts and longerons may be

repaired by adding external pieces as explained for spars and other members. In some cases it is necessary to add a new length to such members, especially where the damaged part is external and is exposed to the airflow.

The end or ends to which the new piece is to be joined is first sawn and carefully planed so as to taper over the last few inches, the part to be added being carefully cut to length and likewise tapered. It should be tried in position and worked to a perfect fit, after which it is glued under pressure and taped (see Fig. 44).

The splice in important structural members should be made at an angle no coarser than 1 in 9.

If the joint is being made in a member of some unit, such as a fuselage, the structure should be firmly supported and completely aligned before the repair is commenced.

Skids.—Broken skids are seldom worth repairing, although sometimes new lengths are spliced into position. In this case the splices should always slope down from front to back. Such splices cannot be taped,

but instead a few brads or screws may be used.

To replace a skid the glider should be hung up on one end, or even turned over on its back, and all skid screws removed. The old

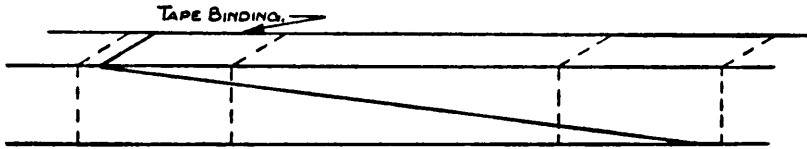

FIG. 44.—Longeron Splice.

parts can then be taken off, and the new skid screwed into position.

When glue is used for assisting in the attachment, the old glue should be scraped off and the surface sand-papered so as to ensure a good joint being made.

CHAPTER XIV

THE SOARING SITE

Launching Methods.—Most soaring to date has been carried out from hill sites, and for this reason the hill site will receive most consideration here. There are, however, four distinct methods of initiating soaring flight. They are :—

- (a) Manual, or auto-, launching
- (b) Auto-towing
- (c) Winch-launching with a long cable
- (d) Aero-towing.

The last three methods may be carried out from flat ground, and soaring flight continued either by flying to a suitable hill, or by the utilization of thermal currents. The advantages of aero-towed starts are that the towing aircraft can fly to any available source of lift, and the initial height is almost unlimited.

Auto-towing has the advantage over winch-launching in that the cable remains of constant

length. The shortening cable, unavoidable in winch work, can be largely compensated for by the use of a very long cable; there is far less wear and tear, and the condition of the intervening ground between the winch and glider is relatively unimportant, so that winch-launching appears to be superior to auto-towing.

A portable winch, that is one attached to, or forming part of, a car, offers very great possibilities, since it may be driven with the glider to any convenient point near a source of ascending air, and there operated at little cost and with little loss of time.

The chief factors governing the suitability of a hill site are as follows:—

1. Height of crest above surrounding country
2. Position of ridge relative to winds
3. Length of ridge
4. Nature of surrounding country
5. Average gradient of slope
6. Unobstructed passage for wind
7. Nature of surface
8. Constant height along ridge
9. Evenness of slope.

Height of Hill.—This is one of the most important factors, since the height to which up-currents extend is roughly proportional to the height of hill. The minimum height for the formation of up-currents suitable for soaring is roughly 100 feet, although, of course, this depends also on the angle of slope and the nature of the surrounding country. A 200 ft hill provides very satisfactory conditions but, for high performance and cloud flying, altitudes of one, or even two, thousand feet are desirable.

Cumulus clouds are seldom seen less than 1,000 feet above the earth and, although their influence extends for some hundred feet below, the occasions on which cloud flights can be carried out from hills of under 500 feet are not likely to be very many, unless winch-launching is resorted to.

At the same time there are certain disadvantages associated with great altitudes, which tend to increase with height. Owing to the falling off of the air's density in the higher regions, winds of greater velocity are necessary for soaring, although this is



THE "GRUNAN BABY" IN SOARING FLIGHT.

compensated for to a large extent by the bigger intensity of winds generally associated with great heights. Weather conditions are often inferior in the higher regions owing to low cloud (not cumulus), high gusty winds, snow, etc., and the difficulty of returning machines to the hilltop is generally more difficult, unless there is a good road for transport.

Position of Hill relative to Winds.—The ridge should for preference face the prevailing wind. It is very useful if slopes are available for all wind directions but such configurations are very hard to find, apart from which such a site could not possess all the other desirable qualities mentioned. In England the most common wind directions are S.W. and N.W. with a fair proportion of W. and S. Easterly winds are not very prevalent and, when they are present, conditions are seldom ideal for soaring.

The best site, then, from this point of view, would appear to be a ridge forming a spear-head facing W., with the two arms forming an angle of roughly 90° , and each being from one to ten miles in length. Sailing flights

would be possible in all winds from N.N.E. through W. to S.S.E., an inclusive angle of 225° .

Another good configuration is a "U" shape with both arms stretching towards the east. The range of available wind direction is even larger than before, the angle being from N.N.E. through W. to E.S.E., or 270° . The western slope should be at least 1 mile in length and there would be extremely few days when soaring could not be carried out, provided, of course, that sufficient wind is present.

The next best conditions are obtainable with a long straight ridge facing S.W., W., or N.W. and in each case flying is possible through a range of roughly 130° .

Length of Range of Hills.—Soaring flight can be accomplished along the face of a hill having a length of about $\frac{1}{4}$ mile, or even less under good conditions, but the limits of flight are very confined, besides which great heights cannot be attained, owing largely to the 'spilling' effect of the wind; that is the tendency to flow round the sides of the hill instead of over the top.

This end effect is not of such great importance with a ridge extending a mile or more in length, but the best hill is one that continues, more or less unbroken, for at least 10 miles, as sailing flights can there be made over the entire length and this gives the best introduction to really long cross-country flights.

The height of the range should, for preference, remain fairly constant along the length, although occasional gaps of one or two miles provide very instructive practice in flying from one hill to another, besides teaching the effects of winds of varying velocity and direction.

Surrounding Country.—The next consideration concerns the nature of the country surrounding the site. Of foremost importance there should be an unobstructed passage for the wind for at least 5 or 10 miles from the hill-face. Ground that slopes gently away is best.

There should be other hills, situated not too far from the selected site, for the prolongation of sailing flights and whither occasional excursions may be made for the purpose of

gaining experience under different conditions. As most long-distance flights to date have been made 'with' the wind, the country behind the hill should be suitable for this purpose.

Gradient.—The best *average* gradient appears to be in the neighbourhood of 1 in 3 and should not exceed 1 in 2, since with steeper slopes the wind-flow no longer conforms to the shape of the hill but takes the line of least resistance and thus forms its own gradient. The result is that eddies are formed which may be a danger to soaring craft and the gradient of the wind path does not increase to the extent that might be expected.

A gentle curve-in at the base of the hill and well-rounded top are important for smooth flow, in the same way that the rotor blades of turbines have to be well designed in this respect.

Good soaring conditions are, however, often present with very steep hills or cliffs, but the danger of eddies, as previously mentioned, must not be overlooked. These dangers are most pronounced with high,

gusty winds and the regions to be avoided are the cliff face and top.

Nature of Surface.—The slope of the hill should be uniform throughout, not merely the average gradient, so as to provide even air-flow. Irregular surfaces cause local eddies and retard the wind velocity near the ground.

The best surface growth is grass, or low heather. Gorse is quite satisfactory provided that sufficient open spaces are available for launching and landing, while the thermal currents associated with gorse when subjected to the sun's heat are of advantage to soaring flight.

Clumps of trees and woods do not severely affect the airflow, but a few old trees here and there render the site difficult, and often dangerous to operate on. Grass-land at the foot of the hill is, of course, best for landing purposes, but plough-land, ripe corn, stubble and other forms of growth giving rise to heat currents, due to reflection from the sun, assist the upward trend to the air, which is a feature of importance on warm days with little wind.

The ideal site may never be found, but any one possessing a fair proportion of the qualities enumerated above will provide very satisfactory conditions for soaring and training. There are still other considerations, such as proximity to populated areas, accessibility by rail and road and the possibility of erecting enclosures for obtaining gate money, if the site is to be used by a club, or for competitions.

Finally, some gentle slopes, preferably at the foot of the main hill, and facing most wind directions should be available for elementary training purposes.

APPENDIX I

B.G.A. INSPECTOR'S REPORT ON CONSTRUCTION OF GLIDER FOR CERTIFICATE OF AIRWORTHINESS

A. *Timber.*

1. State kind of timber, and grade, used in construction.
2. Does this comply with the drawings and specifications ?
3. Is the timber and plywood of good quality for all stressed components ?
4. If any defects are present, such as knots or cracked grain, state nature of defects and positions.
5. Give particulars of all joints and splices in the main spars and longerons. State angle of splice.
6. Have all plywood joints on the leading edge and fuselage been well feathered ?
7. Have glued joints been properly made and under pressure ?
8. Has a good quality glue been used ?
9. Are all holes properly drilled ?
10. If any king-posts are employed, are they well made with grain parallel to the length, plywood covered, held firmly with fillets, and copper lined at the cable connection point ?
11. Has all woodwork been treated against weather effects ?

B. *Fittings and Metal Parts.*

1. Has only metal to aircraft specification been used for all stressed parts ?
2. Are tubes, wires, cables, and bolts to aircraft specifications ?
3. Are any hinges held by wood screws ?
4. Have all bolts been properly secured with nuts and split pins, or spring washers ?
5. Have large washers been fitted to all bolts and nuts resting on wood ?
6. Are all bolts used in the control system burred over ? If not, how are they locked ?
7. Have all wire eyelets and splicings been properly made, and heart thimbles inserted in cable splicings ?
8. Have all bolts been inserted with their heads upwards or forwards ?
9. Have all metal parts been suitably treated against corrosion before assembling ?
10. Are all welded joints sound ?
11. Are all working joints and pulleys well greased or lubricated ?
12. Do all the pulleys run freely ? Are they fitted with guards, and set in the direction of pull in the cable ?
13. Can all pulleys be easily inspected ?
14. Do all control cables run clear of structural members ?
15. Are the controls free from backlash ?
16. Are any of the control levers subjected to any undue initial tension ?
17. Are any bracing wires unduly tight, causing undue initial tension ?

C. General.

1. Are all controls correctly connected?
2. Do all dimensions agree with the drawings?
Check spars, gauge of fittings, bolts, struts, and strength of wires and cables.
3. What is total weight of machine (less pilot)?
4. What is the position of centre of gravity of the machine (with pilot) as determined by weighing?
5. Is the control column central with all control surfaces in their neutral position?
6. Are the following correct?
Fuselage at right angles to wings, horizontally and vertically? Tail unit setting to main plane?
7. Is fabric satisfactory, properly attached and doped, waterproof, and provided with moisture outlets?
8. Is the fuselage provided with water outlets?
9. Have precautions been taken (by upholstering the cockpit) to protect the pilot in the event of a crash?
10. Is a satisfactory harness fitted? Does it attach to a main member? Is it sprung?
11. Is the launching hook strong and well shaped?
12. Is there any possibility of the launching rope catching on the skid front or any other member?
13. Has provision been made for holding back the machine during the launch, and are the loads so imposed properly transmitted to the longitudinal members?

240 GLIDING AND SOARING

14. Test all control surfaces for rigidity and torsion.

15. Oscillate the wing tip by imparting gentle pushes, and time the beats. State number of complete beats per minute.

16. Give a general report on the construction of the complete machine.

APPENDIX II

B.G.A. MANUFACTURING REQUIREMENTS FOR GLIDERS AND SAILPLANES

I. GENERAL CONDITIONS.

A. To secure interchangeability, suitable limits must be clearly stated on the drawings for dimensions affecting the assembly or functioning of the parts. These limits, which should be as large as possible, cannot be settled arbitrarily, but depend upon the degree of accuracy of manufacture and the working tolerances found desirable in production.

B. The B.S.I. standard limits and fits for engineering, Report No. 164, are recommended for use.

2. GENERAL LIMITS.

The following general limits will apply.

A. *Bolt holes.*

(i) Bolt holes in wood should be drilled plus $\frac{1}{8}$ to $\frac{1}{32}$ inch over nominal bolt diameter.

(ii) Bolt holes in metal should be drilled plus $\frac{1}{64}$ inch over nominal bolt diameter.

(iii) The position of the bolt holes in the timber should not vary more than $\frac{1}{8}$ inch from the position of the bolt holes in the fitting.

B. (i) Dimensions of all metal parts are to be within plus or minus $\cdot 02$ inch except as otherwise specified.

(ii) Inside radii of *sharp* bends in metal fittings must not be less than twice the thickness of the sheet.

(iii) If the inside radii of bends is made $2\frac{1}{2}$ times the sheet thickness or over, there is no need to heat treat, but where such lugs are subject to wracking loads, packing washers should be fitted shaped to back up the bends.

(iv) Angles of lugs, sockets, etc., must be within plus or minus 2° of specified angle.

C. *Screw Threads.* Should be of standard B.S.F. or Whitworth form and to B.S.I. tolerances, except where wider limits can be permitted, in which case the drawings shall specify.

D. *Wood Sections.*

(i) Dimensions of cross section are to be within tolerances of plus $\frac{1}{32}$ and minus 0 in.

(ii) Lengths must be within plus or minus $\frac{1}{32}$ inch per foot run.

3. SUGGESTIONS FOR INTERCHANGEABILITY.

A. *Hinge arrangements, etc.*

(i) In an arrangement of hinges having centres up to 7 ft 6 inch the inner hinge should be the datum, but for centres of greater size hinges as nearly central as possible should be used.

(ii) The datum hinge must have as small a clearance as possible for location purposes, whilst the limits of the other hinge centres from the

datum are to be plus or minus $\frac{1}{16}$ inch with clearances between male and female parts large enough to cater for this tolerance.

B. *Main Plane Root Attachments.*

Datum spar clearance in attached fitting is to be $\frac{1}{8}$ inch, and on other spars $\frac{1}{8}$ inch for each one foot spar centres.

APPENDIX III

B.G.A REGULATIONS GOVERNING AUTO-TOWING

1. All gliders used for auto-towing must have a special Certificate of Airworthiness for that purpose, issued by the British Gliding Association. For training purposes a single track undercarriage (*i.e.* one with a single wheel and/or skid) is inadvisable.

2. Any existing glider holding a normal C. of A. which is to be adapted for auto-towing must be re-approved for the special C. of A. For this an appropriate fee will be charged.

3. The towing hook shall be fitted with a "fool-proof" release with the operating device close to the pilot's hand, and shall be of a type approved by the British Gliding Association.

4. Means for locking the release should be provided. (It is essential that beginners should be entirely under the control of the instructor.)

5. The towing cables shall be of not less than 10 cwt breaking strength and of extra flexible construction. It must be examined before each flight. A shock absorber consisting of a double link about fifteen inches in length of $\frac{5}{8}$ inch braided elastic cord, with a 10 cwt check cable to allow 50% extension should be fitted. Good quality $\frac{3}{8}$ inch diameter sash cord may be used in lieu of steel cable if desired.

6. An Instructor with experience of auto-towing shall always be in the car with the driver, seated in such a position that the glider and pupil are in full view throughout the flight.

7. Towing car shall be of sufficient power and reliability to make a quick "get-away" and avoid stalling the glider close to the ground. A minimum of 20 h.p. is recommended.

8. On wet grass or on ground where wheel-slip is likely to occur, chains should be fitted to both driving wheels.

9. The glider shall be fitted with adequate harness for the pilot (and passenger). Harness to be of a type approved by the B.G.A.

10. If primary type gliders are used for auto-towing they shall not be taken to a greater height than 10 feet above the ground. Any infringement of this regulation will entail suspension of the Certificate of Airworthiness.

11. The point of cable attachment shall be within the limits as specified below:—

(a) For elementary training purposes: within the angle formed by lines drawn through the C.G. position (loaded), forwards and downwards, at 10° and 40° to the horizontal, and

(b) For advanced work: within the angle formed by lines drawn through the C.G. position (loaded), forwards and downwards, at 10° and 80° to the horizontal.

It is recommended that an airspeed indicator be mounted on the car well within the vision of the driver, and connected to a pitot head mounted on a strut, at least five feet above any part of the car.

APPENDIX IV

B.G.A. REGULATIONS GOVERNING AEROPLANE TOWING

1. Only pilots in possession of the "C" Soaring Certificate and who have completed 2 hours motorless flying, or "A" licensed aeroplane pilots who have completed 10 hours solo flying, will be allowed to pilot gliders towed by aeroplane.

2. No glider shall be used for aero-towing unless in possession of a current B.G.A. Certificate of Airworthiness duly endorsed for aeroplane towing. Proof that the necessary strength requirements have been complied with must be shown.

3. The strength requirements, extra to those for normal category gliders, are :—

(a) The fuselage shall be capable of withstanding a load at the cable attachment position of 200 lbs horizontally, changing to 400 lbs vertically, with a factor of 2. The loads to be taken as acting separately and together.

(b) Suitable drag bracing shall be present.

4. No elementary training type glider will be approved for aeroplane towing.

5. Gliders shall only be towed by aeroplanes properly equipped for aeroplane towing approved

by the Air Ministry, and with the Certificate of Airworthiness endorsed to that effect.

6. The towing cable shall include a "weak link" to fail at a load equal to the loaded weight of the glider. The link to be fitted at the glider end of the cable.

7. The minimum length of cable shall be 300 feet.

8. All gliders used for aeroplane towing must have a release definitely operable by the pilot.

9. Gliders in aeroplane towed flight must not exceed a speed of 60 m.p.h.

10. The angle made by the towing cable to the horizontal must not exceed 20° .

APPENDIX V

B.G.A. REGULATIONS GOVERNING POWER LAUNCHING

Only methods of power launching as approved by the B.G.A. shall be used. Clubs or individuals wishing to make use of other methods must first submit full descriptions of their scheme for approval by the B.G.A.

Approved Methods.

The following methods are at present approved for general use :—

1. The launch should be made with the aid of one motor-car attached to the glider with about 60 feet of double $\frac{5}{8}$ in shock cord and a length of rope of at least 100 feet inserted between the glider and the shock cord. For launching, the glider should face directly into wind with the car in front, the tail being held back in the usual manner or by a quick release. A small flag or other suitable mark should be placed in front of the glider at a distance equal to twice the length of elastic. The launch is made by driving the car forward until the shock cord is stretched to the double length mark when the release shall be made. As soon as the elastic falls clear of the glider the car should be driven to the left to avoid collision.

2. This method is similar to (1) but employs a pulley affixed to the ground at a distance of at least 200 feet in front of the glider, at which point the rope is turned through an angle of 90° , so that the motor-car is driven in a direction at right angles to that of the glider. The shock cord is inserted between the pulley and the car so that only the rope runs over the pulley.

Regulation (2) is of the utmost importance with this method of launching.

Regulations.

Note.—Power launching has a greater element of danger than the orthodox launching team method and if used, extreme care should be exercised.

These regulations refer only to launching done with the aid of a motor-car in place of the usual launching crew. (Auto-towing is covered by separate regulations.)

1. Power launching shall only be used when a qualified instructor superintends its use.

2. For any method of power launching, a quick release, operable by the pilot, must be incorporated. The release lever shall be as close to the pilot's hand as can be arranged. The launching hook should be of the open "drop off" type.

3. A pilot flying any new type of machine shall receive gentle launches for the first few flights and these shall be made by the shock cord method.

4. In power launching the speed and direction of the wind must be carefully estimated or measured and allowed for in the speed of the launch.

5. Private Groups or individuals are recommended not to employ this method of launching unless in possession of at least the " B " Certificate.

6. It is recommended that the pilot shall not give the command to start but that this should be done by someone near the machine on receiving a signal from someone in the car, or standing near the flag or mark.

7. In any method employing the use of a pulley, care should be taken to make sure that it is well fixed to the ground by two or more long stakes, driven well in and roped together, and the pulley should be kept well greased to prevent overheating and possible seizure. A pulley with large flanges is recommended and it should not be possible for the rope to ride over or jam in any way.

Note.— The joint between the cable and shock cord should be well made and periodically inspected.

APPENDIX VI

B.G.A. PROVISIONAL REGULATIONS GOVERNING WINCH LAUNCHING

1. Only pilots in possession of the "C" Soaring Certificate shall be allowed to operate by the winch launch method.

2. The strength requirements, extra to those for normal category gliders, are :—

(a) The fuselage shall be capable of withstanding a load at the cable attachment position of W lb horizontally, changing to W lb vertically, with a factor of $1\frac{1}{2}$. The loads to be taken as acting separately and together.

(b) Adequate drag bracing shall be present.

3. The towing cable shall be of not less than 10 cwt breaking strength but must have a "weak link" of breaking strength W , and be of extra flexible construction. It must be examined before each flight.

4. The point of cable attachment on the glider shall be within the angle formed by lines drawn through the C.G. position (loaded), forwards and downwards, at 10° and 80° to the horizontal.

5. The towing hook shall be fitted with a "fool-proof" release with operating device close to the pilot's hand, and shall be of a type approved by the British Gliding Association.

6. The glider shall be fitted with adequate harness

for the pilot (and passenger). Harness to be of a type approved by the B.G.A.

7. Two pairs of rollers shall be fitted at the egress of the cable to prevent fouling. One pair shall be placed vertically and the other pair horizontally.

8. Cutting shears shall be attached to the winch for severing the cable in the event of accident and shall be so placed that they may be immediately operated by the winch operator or an assistant.

9. In winch launching the speed of the wind must be carefully estimated or measured and allowed for in the speed of the launch.

W stands for the weight of the machine, loaded.

INDEX

- A**
Aerodynamics, Elementary,
Ch. II
Aerofoil, the, 28
Aero-towing, Ch. X, 175-9
Ailerons, 49
Aluminium, 183
Angle, critical, 28, 33
Archdeacon, 18
Ash, 181
Auto-towing, Ch. X
 " apparatus,
 158-161
 " training by, 161-7
Auto-towed start for hill
 soaring, 167
Axes of movement, 40
Axis, pitching or lateral, 40, 113
 " rolling or longitudinal, 40
 " yawing or turning, 41
- B**
Bacquerille, Marquis de, 12
Bernier, 12
Bleriot, 18
Brads, 187
- C**
Cable joints, 209
Cables, 187
Cayley, Sir George, 12
Centre of gravity, 48
 " " pressure, 43
Certificate " A ", 81, 82
 " " B ", 86, 87, 96, 101
 " " C ", 108, 115-16,
 121
Chanute, 16
Cloud flying, 146-150
- Control, lateral, 76
 " surfaces, 204-6
 " system, the, Ch. III
Controls, 60
' Crested Wren ', 125
- D**
Da Vinci, Leonardo, 11
Dope, 185
Drag, 31, 38
 " bracing system, 222
Dual instruction, training by,
 99, *et seq.*
Dunne, 18
Duralumin, 183
- E**
Elevator, the, 45
Enamel, 186
Erection, Ch. IV
- F**
Fabric, 185
 " attachment, 198-200
 " repairs, 223-5
' Falcon ', the, 104-6
Ferber, 18
Fin, 46
Fittings, metal, 206
Flat plate, airflow past, 26
Flights, cross-country, 154-6
Forces of glider, 34
Fuselage construction, 200-4
- G**
Glider, elementary training, 65
 " improved performance,
 87
Gliders, types of intermediate,
 104-6

Glue, 184
 Groenhoff, 21
 'Grunau Baby II', the, 105, 106

H

Hands, position of, 80
 Harth, 20
 Hentzen, 20
 Hirth, 21
 'Hols der Teufel', the, 105, 106
 Household, Goodman, 13

I

Incidence, 55
 Instruments, 141-2

K

'Kassel 20', the, 105, 106
 ,, two-seater, 126,
 128
 'Kestrel', the Dunstable, 125,
 128
 Klemperer, 19
 Kronfeld, 21

L

Landing, 116-19
 ,, on hilltop, 137-9
 Landings, side-wind and down-
 wind, 94, *et seq.*
 Langley, 16
 Launching, 129
 ,, mechanical, 168-
 172
 ,, methods, 128
 ,, winch, 172-5
 Le Bris, 13
 Lift, 31, 38
 Lilienthal, Gustave, 14, 15
 ,, Otto, 14

M

Maintenance, Ch. XIII
 Maneyrol, 20
 Martens, 20
 Materials of Construction,
 Ch. XI

Maxim, 16
 Moillard, Pierre, 14

N

Nehring, 21

P

Pilcher, Percy, 15
 Plywood, 181
 'Professor', the, 123, 128
 'Pruffling', the, 104, 106

R

Repairs, Ch. XIII
 'Rhönadler', the, 126, 128
 Ribs, 193
 ,, repairs to, 220-2
 Rigging, Ch. IV
 Rudder, 46
 ,, use of, 77

S

Sailing, Ch. VIII
 ,, contour, 143-6
 ,, flights, extended,
 Ch. IX
 Sailplane, the, 122
 ,, first flights, 128
 ,, types, 123
 'Scud II', the, 125, 128
 Sideslip, 89, 91, 133-6
 Site, the soaring, Ch. XIV
 Skids, 226-7
 Slides, ground, 68
 Soaring, Ch. VII
 ,, flight, 107, *et seq.*
 ,, ,, duration, 120-1
 ,, machine, the, 103
 ,, thermal, 150-4
 Spar repairs, 215-19
 Spars, 190-3
 Speed, effect of, 32
 ,, stalling, 36, 92
 Spinning, 139-141
 Splices, 225-6
 Spruce, silver, 180
 Stall, 28, 33

Stedman two-seater, 127, 128
 Steel, 182
 Strong winds, soaring in, 119

T

Tailplane, the, 43, 54
 Tail-swishing, 136
 'Tern', 123-4, 128
 Training, Advanced, Ch. VI
 „ by auto-towing,
 161-7
 „ Elementary, Ch. V
 Turning, 88, 111, 131-3

V

Varnish, 186
 Voisin, 18

W

Weight, pilot's, 74
 Weiss, Jose, 18
 Welding, 207
 'Wien', 123
 'Willow Wren', 125
 Wing construction, Ch. XII
 Wires, 187
 Wright, the brothers, 16, 17

THE SPORTSMAN'S LIBRARY

The following are *some* of the volumes in this Series. A *complete* list may be obtained from the Publishers.

RIDING AND HORSEMANSHIP. By William Fawcett.

COARSE FISHING. By A. J. Rudd.

SEA FISHING. By D. P. Lea Birch.

GUN DOGS AND THEIR TRAINING. By Atwood Clark.

MAKING A SHOOT. By Lieut.-Gen. Sir John Goodwin.

TROUT FISHING. By H. D. Turing.

SALMON FISHING. By W. J. M. Menzies.

BIG GAME OF AFRICA. By Major H. C. Maydon.

DEERSTALKING. By Patrick R. Chalmers.

GLIDING AND SOARING. By C. H. Latimer-Needham.

THE MODERN GUN. By T. D. S. Purdey and Capt. J. A. Purdey.

FOXHUNTING. By William Fawcett.

HIGHLAND SPORT. By Patrick R. Chalmers.

ROUGH SHOOTING. By G. K. Yeates and R. N. Winnall.

SAILING. By Patrick Egan.

FENCING. By Percy E. Nobbs.

ROCK AND HILL CLIMBING. By W. T. Palmer.

PHILIP ALLAN & CO., LTD.
69 Great Russell Street, London, W.C.1

