

CONTROL LINE  
MODEL AIRCRAFT

## ABOUT THE CONTENTS

*CONTROL LINE MODEL AIRCRAFT* is intended to offer suitable guidance and instruction to the many thousands of ordinary aeromodellers who are already struggling with the initial stages of flying, or hope to do so in the near future. It does not pretend to teach the expert anything—as if it could do?—but it will help the newcomer to this fascinating branch of flying to avoid the sometimes expensive pitfalls that can beset him. It answers in its pages many of those questions that have always seemed too obvious for the well-known authorities to even mention; it takes the would be flyer in easy steps from his first model, usually a kit, to his first loop.

To its compilation has gone the unique resources of the *Aeromodeller* staff, its own flying field and workshops, its many and expert correspondents, and much of practical value gleaned on staff visits to America and Europe.

We have frankly searched the best material available for skilled advice on all aspects and would take this opportunity of thanking our many friends who have helped and the numerous sources which have provided information.

In addition long and painstaking experience was gained the hard way as absolute beginners, learning from our own errors, through a bucketful of broken props to comparative skill.

This book does not tell the reader how to win contests, or how to break speed records, but it does attempt to offer the average aeromodeller all that is necessary to really enjoy the fascinating sport of control line model building and flying.

# CONTROL LINE MODEL AIRCRAFT

An introduction to the popular sport of control line flying, with authoritative information on all aspects drawn from British and foreign sources, and the practical experiences of the *AEROMODELLER* RESEARCH STAFF

Compiled by  
D. J. LAIDLAW-DICKSON  
and Edited by  
D. A. RUSSELL, M.I.Mech.E.

A

## HARBOROUGH

PUBLICATION

THE AERODROME  
BILLINGTON ROAD, STANBRIDGE  
NR. LEIGHTON BUZZARD, BEDS.

1949

*Also Compiled by*  
*D. J. LAIDLAW DICKSON*  
*and Edited by*  
*D. A. RUSSELL, M.I.Mech.E.*

MODEL DIESELS  
AEROMODELLER ANNUAL

*Distributors to the Book Trade*  
HORACE MARSHALL & SON, LTD., LONDON, E.C.4.

*Printed in Gt. Britain by*  
THE CROYDON TIMES, CROYDON, SURREY

## FOREWORD

In preparing *Control Line Model Aircraft* we have endeavoured to take a middle course and present a book that is neither too advanced for the beginner nor too elementary for the aeromodeller who has progressed a little on the way. It has been assumed throughout that the reader will have some knowledge of aeromodelling, though not necessarily of control line building and flying. We have made no attempt to provide information or instruction for the advanced or expert flyer; such aeromodellers will normally have a fund of special knowledge of their own and require less text-book guidance than further opportunities to practise on the actual flying field.

Available American and continental sources have been carefully sifted to provide as much useful information as possible, bearing in mind that the average British enthusiast is limited by the types of engine readily obtainable in this country so that some overseas methods are not always entirely suitable here.

Our advice on flying has been learned the hard way by our staff at Eaton Bray, who have one and all held the lines at some time or other with varying degrees of success. Starting as complete novices, everyone of them made exactly the same mistakes in approximately the same order, despite the example of those flying before them, and we feel justified in assuming that the average aeromodeller will be equally prone to find these same pitfalls in his turn.

We are conscious that much has been left unsaid on the subject of control line flying; that many aspects have been touched upon but lightly; and that certain controversial points may have been left unanswered; but nevertheless do feel that in offering *Control Line Model Aircraft* to our readers, we have at least started them on the right path from their first model to their first loop.

SPRING, 1949

D. J. LAIDLAW-DICKSON

D. A. RUSSELL

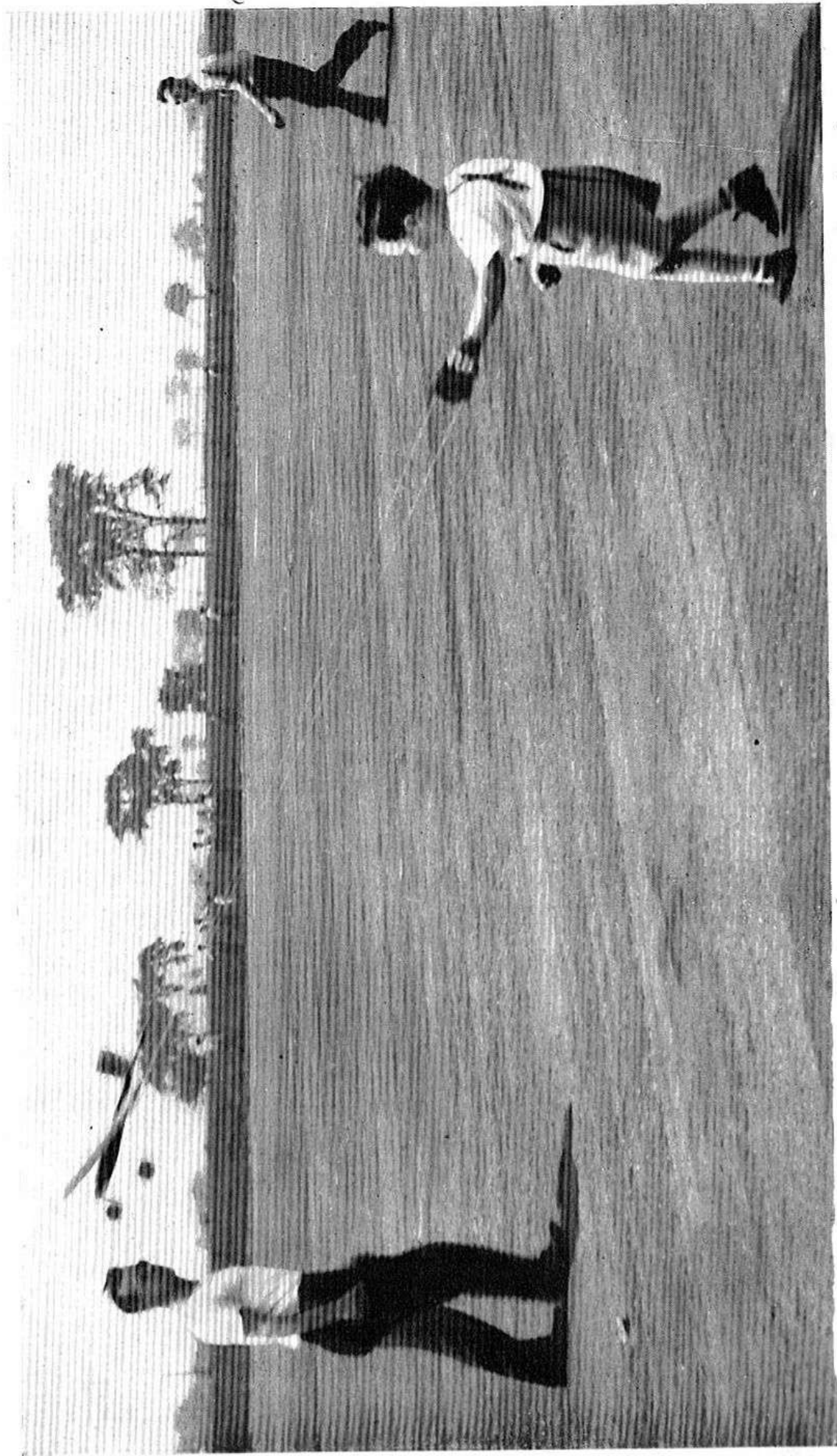

Child's play ! This youngster shows his elders the way it should be done. While proud fathers will be eager to groom their offspring for such performances it is only fair to warn them that the road to success may well be paved with broken prop blades to mention the very least of the horrible probabilities.

# CONTENTS

Chapter I	THE BEGINNING OF IT ALL	...	...	...	7
Chapter II	CHOICE OF A FIRST MODEL	...	...	...	12
Chapter III	DESIGN CONSIDERATIONS	...	...	...	19
Chapter IV	THE FUSELAGE	...	...	...	31
Chapter V	WINGS	...	...	...	43
Chapter VI	CONTROL SYSTEMS, CONTROL PLATES, ELEVATOR HORNS AND HINGES	...	...	...	52
Chapter VII	EMPENNAGES	...	...	...	61
Chapter VIII	UNDERCARRIAGES AND DOLLIES	...	...	...	67
Chapter IX	ENGINES, COWLINGS AND STARTERS	...	...	...	75
Chapter X	AIRSCREWS—PRACTICAL AND THEORETICAL	...	...	...	86
Chapter XI	CONTROL LINES, REELS AND HANDLES	...	...	...	93
Chapter XII	ELEMENTARY FLYING	...	...	...	99
	INDEX	...	...	...	111

## *Appendices*

I	SPEED TABLE	...	...	...	113
II	S.M.A.E. AEROBATIC CONTEST SCORING SCHEDULE	...	...	...	114
III	TYPICAL CONTINENTAL AEROBATIC CONTEST SCORING SCHEDULE	...	...	...	115
IV	S.M.A.E. RULES GOVERNING CONTROL LINE FLYING	...	...	...	116
V	WIRE BREAKING STRAINS	...	...	...	117
VI	S.M.A.E. DRAFT SCALE MODEL RULES	...	...	...	118
VII	F.A.I. RULES FOR CONTROL LINE SPEED RECORDS 1949	...	...	...	119
VIII	ANTI-WHIP YOKE PYLON	...	...	...	120
IX	TYPICAL BRITISH COMMERCIAL KITS	...	...	...	121



Jim Walker demonstrates the Sabre Dance. This apparently stalling model is in fact doing a vertical jig with aid of motor control conveyed along the insulated control wires. Lead from handle to battery in the trouser pocket will be noted. It takes an expert like Jim Walker to think up a stunt of this nature, let alone perform it, as he has, regularly and safely all over the States.



## CHAPTER ONE

# THE BEGINNING OF IT ALL

EVERY few years some new world shaking discovery comes along in a blaze of publicity and is heralded as mankind's greatest advance since never mind what, and then, after the excitement has died down, the ordinary man in the street shakes his head and says to himself: "That's all very simple, why didn't *I* think of it first?" So, in our small world of aeromodelling, the really clever advances are things anyone *could* have thought of, but somehow left for the other man to do first. Control line flying of model aircraft came along just like that. While American factories were turning out more and more war material for their Western Allies, model engine supplies became progressively less, until the prodigal American power flyers could no longer afford to let model after model go zooming off into the blue, without hope of engine replacement. Then it was that two model firms, who had come, by different routes, upon the same bright idea of marketing models that would not fly away, and, could, in addition, be actually controlled by the "pilot" during flight, began to reap their reward.

Jim Walker, who has long figured amongst America's brightest model enthusiasts, added to his reputation in the model radio control field, with his clever U-control device, which he was able to patent (Filed 26.12.40), and in consequence has since had the satisfaction of seeing more than half his country's control line kits earning him royalties. Vic Stanzel, another inventive model trader, produced his G-control and roller systems which for some time vied in popularity with U-control, but are now considered less satisfactory in some respects.

Just what is this control line flying? The name is delightfully explicit and means exactly what it says. With the aid of two piano wire lines, or stout fishing lines power driven models are flown in fixed circuits round the controller. One end of each line is attached to a pivot which actuates the elevator in an up and down direction, the other ends are held by the operator attached to a U-shaped handle with a line to each arm of the U, inclination of which moves the wires and so alters the elevator trim. Thus the model will climb, dive or fly level as required. In the case of G-line—which incidentally was on the market some time before Jim Walker patented his device—a single line only is employed attached to the plane slightly ahead of the centre of gravity, and at the other end to a light pole held in the flyer's hand. By raising or lowering the pole the model can be made to climb or dive. Whilst very simple this method has its disadvantages in the somewhat sluggish response to the control.

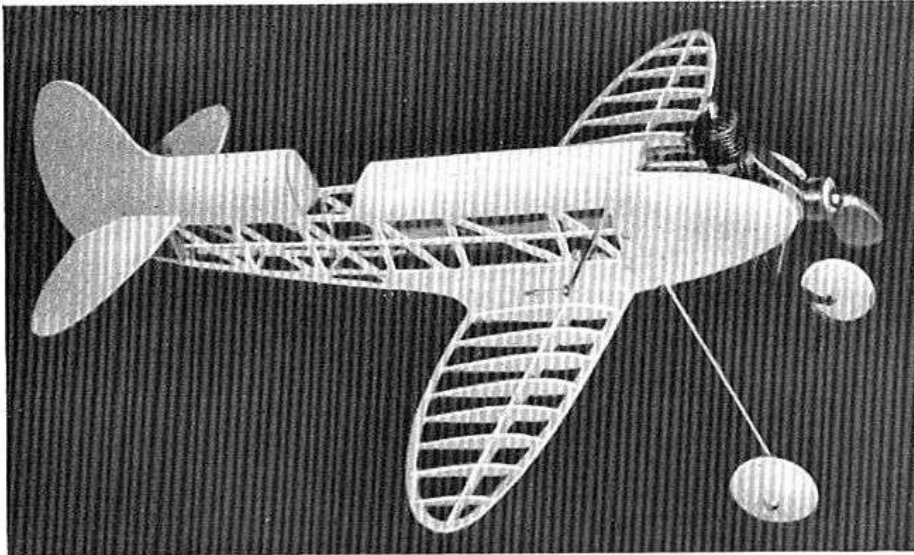

Stanzel Baby Shark, amongst the earliest control line models. This design features the special Stanzel roller control, visible as a projection above the wing root.

In a year or two this freak craze for control line had so prospered as to be a threat to free flight power model flying. In the American model magazines of 1941/2, one comes upon constant and virulent attacks upon this dreadful "swinging a brick on the end of a string" by diehard free-flight fans, and equally powerful letters from the opposition camp proving, by a host of formulae, that it was not flying a brick on a piece of string at all. The entry of America into the World War proved another incentive to control line prosperity. Petrol supplies were short, tyres worn out, and the inevitable family car no longer available to run out to the flying field. But the control liner could fly his model on any odd patch of ground no larger than a tennis court, so who need worry about the distant flying field? In those early years some painful monstrosities saw the light of day in the guise of model aircraft. The smallest possible wing was allied to the largest possible engine, which barely lifted the heavily loaded projectile off the ground, and then proceeded to whirl it round at speeds of over a hundred miles an hour. The enthusiasts were speed hungry and cared nothing for looks. Little by little the thrill of going just a little faster than the next man wore off, and surprised builders found that models could be elegant looking copies of the latest war planes and still fly more than fast enough. Sports models, designed for long life and moderate speeds came into being and the despised "Goats," or converted free flight models, were tried again. Then came the great day when someone discovered that the real future of the sport lay in stunts. We do not know how many models hit the dust before the first loop was achieved; then an outside loop, square loop, inverted flying and all the fun of the flying circus.

Speed still had its adherents, but the American contest rules were amended to bar the freak, and something more aerodynamically plausible took wing, again mounting higher and higher into three figure speeds. Side by side has grown a healthy appreciation of stunt models with a leaning towards scale or near scale design. Old timers of the First World War have taken the air again: Spads, Brisfits, Camels, S.E.'s and the like are common sights on the model field. Age too has been swept from its pedestal by the skill of a thirteen-

year-old, who defeated the flower of the American control line kings in the stunt section and a youngster, certainly no older, in France, who took first place in an international contest. Now the new invasion has come to these shores. How shall we tackle the control line model?

The operative word is surely "control." There are other names for this form of flying, such as "guide line" or "tethered" flying, but we hope we are right in stressing that the future lies in control. Unlike our American friends, we have few engines in this country capable of clocking high speeds—the only really fast machines are those powered by American engines brought back by returning R.A.F. personnel, or acquired through who knows what dubious grey or even black market activities. We should confess at once, that we have had opportunities of trying out the best of the American speed engines, so cannot be accused of sour grapes, but the general run of speed readers will certainly not be able to lay hands on them for a long time. But we do have an unequalled range of small diesel engines that offer trouble-free flight at moderate speeds in all sizes from .5 to 5 cc. A new era may also be dawning for devotees of the older petrol engine with the development over here of the glow-plug, which offers a combination of diesel simplicity with petrol engine flexibility and added urge. Why then should we borrow from overseas when there is the making of an essentially British slant on control line flying? Most of our flying will necessarily take place out of doors—we have few large hangars or armouries available for modellers' use—and so our models must be robust and, again, controllable.

The wind bogey which has led many quite well-known British experimenters to advise against flying in any but the calmest weather, is not really so bad after all. We have consistently flown in all kinds of weather. We have painfully learnt how not to do things to the extent of a bucketful of broken props, and we are firm in the opinion that control line models can be flown on at least half the days of the year, which is more than can be said of free flight. Travel troubles are such that any opportunity for flying without going too far from home is welcome, and here again the control line model can be flown on any school playground, tennis court, or cleared bomb site. The

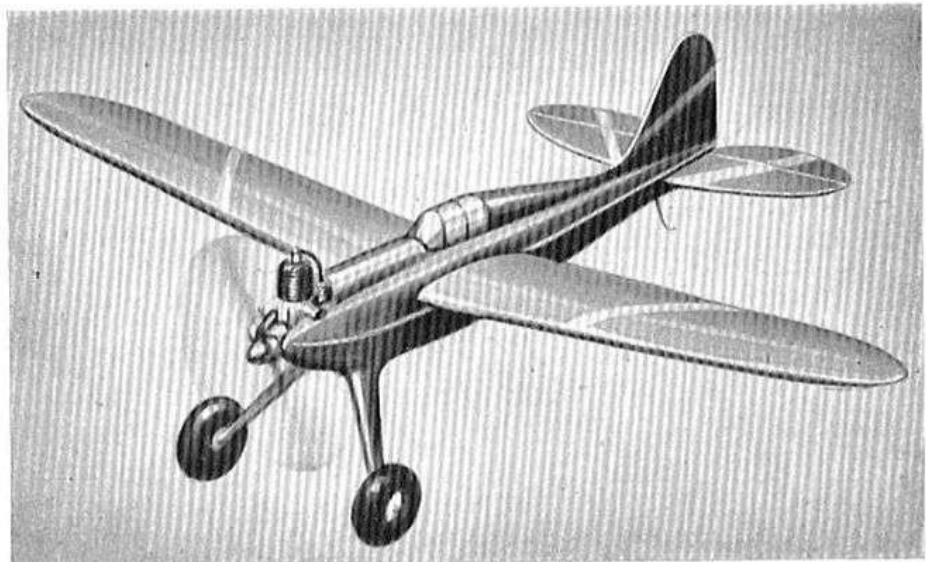

Old timer Fireball—Jim Walker's first U-control kit model that virtually started the craze for control line flying. With certain modifications the selfsame kit is still selling today after eight years.

only proviso is that the beginner should confine himself to the calm days until he can control his model as instinctively as he rides a bicycle : he will then adjust each circuit automatically against contrary winds.

Two forms of control will be used extensively over here. First favourite is likely to be the Jim Walker style, triangular control plate, moving the elevator with a single horn, and thence by two wires which actuate the control plate. The "flight controller" system may have its adherents on the score of simplicity. This device has no control plate, but a double elevator horn, one part for up and one part for down movement. The two leads are fed through a pair of curved metal tubes and thence to the manipulator. This offers slightly more positive response than the plate, but imposes a greater strain on the elevator. G-control in its simplest form may appeal to some as a training method, but the roller mechanism for advanced forms is trickier to make than the other systems and so may not be so much used.

Will speed flying have a following in Gt. Britain? Of course it will : for a year or two at any rate. It is easier to learn to fly fast than to perform any great variety of stunts, so the newcomer will quickly gravitate to speed flying.

Already 60-70 m.p.h. has become the commonplace with engines between 1 and 2 cc. ; considerably higher speeds being claimed for such engines as the E.D. Going up the scale, the British made Noidec is regularly clocking round the three figure mark. As this and other British engines in the larger sizes get into circulation, we have no doubt our speed figures will very closely approximate those recorded in America. It should be borne in mind, however, that atmospheric conditions here do not encourage the same speeds from the same engines using the same fuel as in certain of the American states. We are glad to note that at least one famous oil company is conducting research into model fuels suitable for our climate.

But we certainly see more future than sheer speed. There is a grand opportunity for a wide variety of scale models built round some of the truly miniature .5 to 1 cc. diesels. A range of moderate speed stunt models should attract considerable interest. Already we note most of the model manufacturers are turning for kit inspiration to the medium sized engine as the power unit, and offering general purpose designs in preference to out and out speedsters.

It is interesting to consider for a moment how control line modelling has appealed to other European countries, who have learned it from the hands of visiting G.I.'s. France has developed an interest that turns mainly towards the speed model, based on 5 c.c. or larger engines. In this she has been fortunate enough to possess a number of commercial engines of reasonable power, such as the Micron 5cc. diesel, the new Micron 10cc. glowplug and the 10cc. Rea in the petrol group. A limited number of American engines have also been freely imported. The same goes for Belgium, where American kits and high-powered Hornets, McCoys and the like may be had on demand. To that extent, their development has been American, with access to the original power units to encourage that lead. In Italy, on the other hand, where aeromodelling is of sufficient interest to the rank and file

to support literally dozens of local aeromodelling magazines, little or no such opportunity was available. In consequence, we find a number of under 5cc. designs, including a delightful scale model with engine amidships and driving its air screw via an extension shaft. Manufacturers have now taken the trouble to develop special engines for their fans, first with the Super Tigre of 5.65cc., a robust production of considerable power, and finally with Movo's latest 10cc. design, which in our opinion will prove, at least, the equal of America's best. It seems then, that as soon as control line enthusiasts are sufficiently numerous to lift up any considerable voice, we may hope British manufacturers will take the tip and produce a real job for those who like speed work. Meanwhile, we should make the most of what is to hand. In this connection, we would add, that a number of British engine manufacturers are already well towards producing such engines as well as conducting research on airscrew design. Their first findings, now coming on the market, offer great promise of ultimate success.

Before leaving the subject of early birds in the control line world we must pause awhile, and speak in praise of British pioneers. Let it not be thought we offer any exclusive bouquets to those responsible for the commercial exploitation of control line flying in America. They were clever enough to make a success of it and through their efforts made a wide range of supplies available to the average aeromodeller. But they were not the *first* by any means. Before miniature petrol engines came into being, lone hands struggled with complicated relays and Bowden cables to achieve controlled flying, quite ignorant that they were doing anything out of the ordinary. In the same way, pre-war illustrations in the *Aeromodeller* show a hardy pioneer flying his petrol model on a line. In the words of Solomon, there's nothing new under the sun—though some of those unknown pioneers must be kicking themselves for the chances they missed!

Control line comes to England! Ron Moulton, pioneer British control line flyer, starts up his Voetsak—south African-named model in memory of his own initial control line flights over there.



## CHAPTER TWO

### CHOICE OF A FIRST MODEL

ONE by one the diehard free-flight power modellers are succumbing to the blandishments of the wicked control-liners and graciously accepting the working end of the lines, if only to demonstrate how easy it all is! It is not surprising, therefore, to find the ranks constantly swelling with enthusiasts from more experienced aeromodellers. Their future presents no special difficulties; they already (we hope) have the technical and manual skill to produce models that fly. It is only a question of changing methods and adapting their ideas to a new flight medium. Usually it takes one or two models to complete the change, and in a few weeks the more ambitious of them are happily sketching new ideas on the back of someone else's coffin.

But this semi-experienced group is only a small section of the control line following. Very many are interested in building not only their first control line model—but their first model of any kind! Nowadays it is so very easy, with the modelshop round the corner, to start aeromodelling where the fancy pleases, without any of that painstaking progression from simple rubber jobs via more complicated ones, sail-planes, to the eventual happy day when funds were enough to buy a real engine! Perhaps it is a pity that the glamour of owning an engine of one's own has gone, when it was something to be saved up for and treasured, but life is much more companionable with every next man on the flying field giving a hand and swopping excuses as to why the latest motor won't go though it "went all right at home." There is no reason at all why anyone should not build and fly a control-liner as their first model of any sort. Quite a number of them do manage the building part of it—but the flying side ends too quickly to be anything but a damper on their future progress. We wonder how many of those small advertisements: ". . . Engine for sale, hardly used . . ." must be attributed to this unhappy ending to a first approach. Which of course, is one of the reasons for books like this.

More than half the chances of a successful first model depend on picking the right one to build. By this we certainly do not mean you will never fly Messrs. A.'s kit, but you will be able to get along splendidly with Messrs. B.'s. Because experts perform impeccably with model A does not mean you will be able to do the same: you will probably be far better served with a more modest design that has never shown its prop at a contest. Then later on you will be able to join the experts with something on the lines of that model A which first appealed to you. All that the beginner need worry about for his

first model, is something that will fly in smooth regular circuits, exhibit no particular vices of trim or design, be tolerably easy to construct, and just as easy to repair—and moreover, have no parts that, once broken, involve complete rebuilding of some undamaged section to get them back in place again.

We make no suggestion that the control line beginner should even think of designing his own. The hazards are numerous enough to the unskilled without adding the imponderables of an untried design. Our own first model was a nice own design scale Topsy, that took off in a perfect wingover and landed with a crunch that connoisseurs acclaimed one of the most satisfying they recalled. We have never built another Topsy; but, in the light of present experience, we know that model would have flown perfectly, if handled with our later acquired knowledge. It was just much too advanced for a first model. Manufacturers are turning out kits at an unbelievable rate—new ones seem to be bobbing up every week. All of them will fly, but only some of them in the hands of beginners. It is quite impossible to keep track of new kits, though an appendix gives listing at time of going to press, and equally hard for us to suggest one make in place of another. What we have done, to assist the novice, is to give our candid comments on a fairly representative selection of kits suitable as beginner or intermediate stage flying sent to the *Aeromodeller* for inspection and review, where the manufacturer is happy for staff comments to be made. There are, of course, a large number of other kits on the market examples of which have not been sent to us, either from disinterest on the part of the makers, or for some other reason, where obviously we are unable to guide the would-be buyer. We hasten to add, quite off the record, that there are some very fine ones amongst them, quite as suitable as any we mention by name—but it just happens, no one has sent one along to us. All the kits described

Halfax Sabre, intermediate speed trainer kit, built by our fourteen-year-old office boy with no other help than advice—often contrary—from all and sundry. This design puts up a very good show in all but the least experienced hands, and is a good choice for a first speed model.

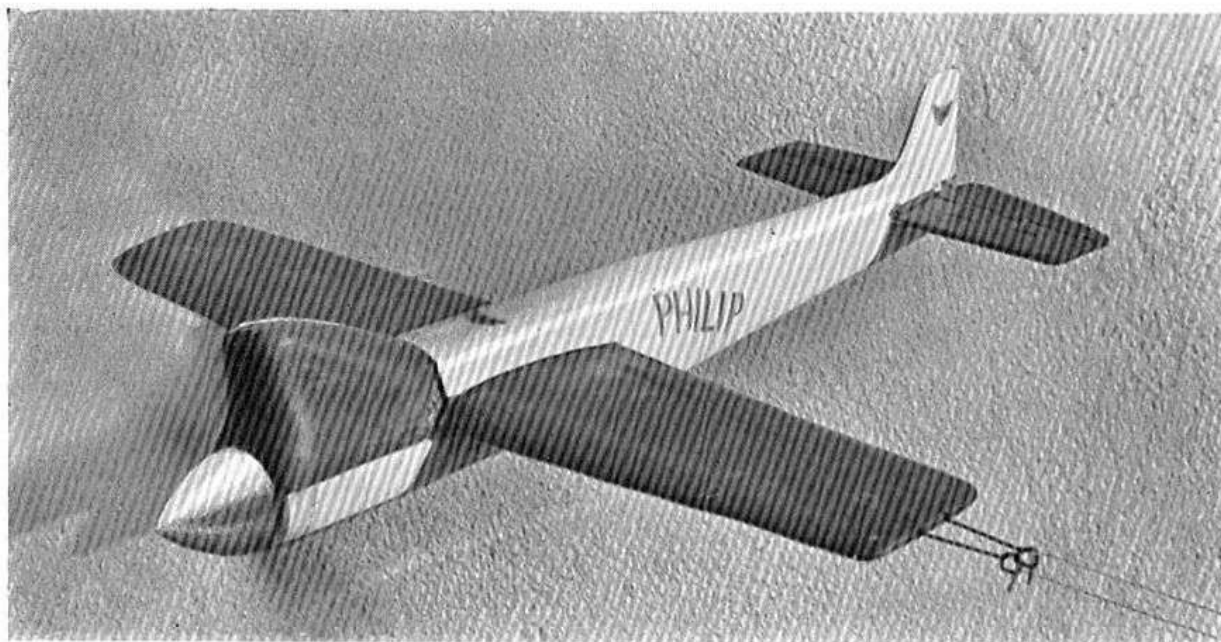

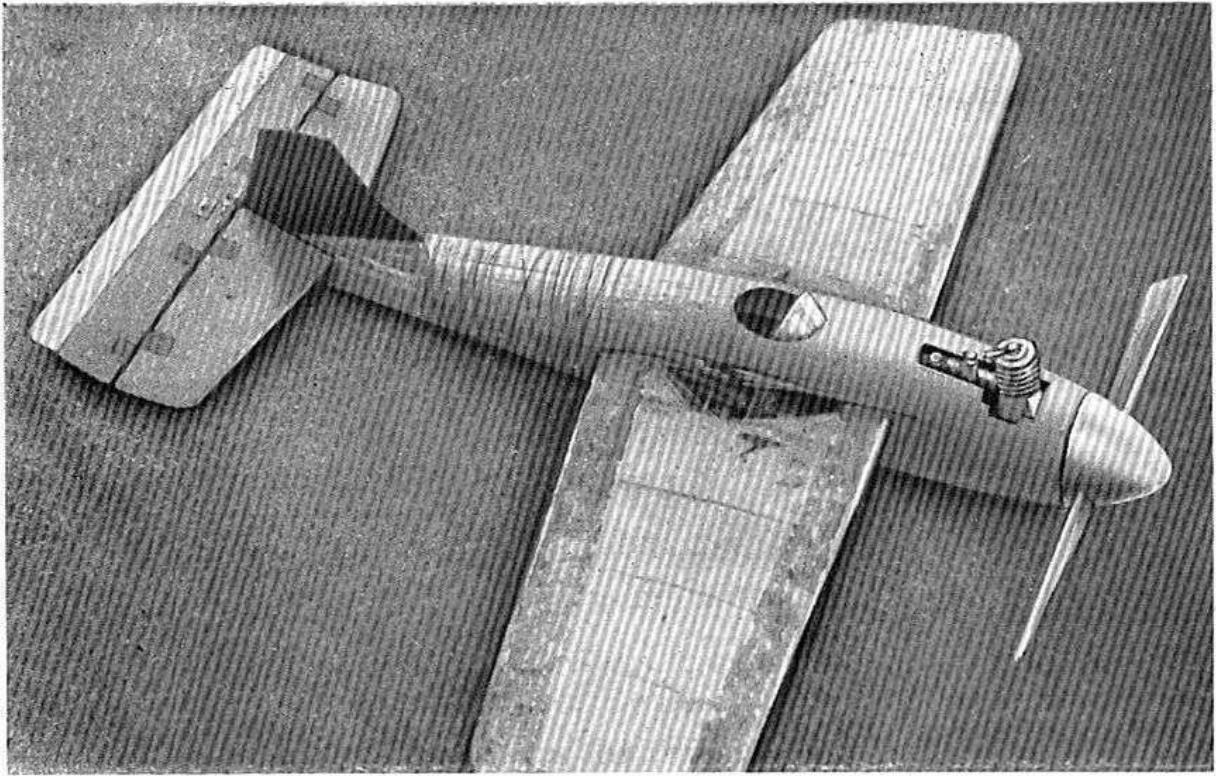

Old Faithful—the much battered Mercury Magnette, second to be built, though with original empennage, that saw most of our staff passed out in their elementary training courses. Note thread binding to hold fuselage together and other honourable scars. Elevator area was increased, as will be noticed, to enable more ambitious flyers to attempt the impossible.

have actually been made up by various members of the Eaton Bray staff and flown on every available occasion to eventual destruction on the very strict understanding, that “who bends ’em mends ’em.” Of the more popular models we note that an original tailplane is flying as the sole remnant of one kit—other parts being renewed piecemeal; several fins have survived into the second generation, as have undercarriages, but mortality rate in mainplanes and fuselages seems to have been high, both from hard contact and from inefficient protection against fuel seepage and consequent rotting. This should serve as a guide for future programmes. Building time, incidentally carried out in leisure, that is non-working hours, has been anything from a weekend to a fortnight’s evenings; little attempt has been made to get exhibition finish, main anxiety has been to have one ready for after-lunch flying the next fine day.

Starting with the small low priced kits, we would mention NANCY. This we flew as sent, with a Frog 100, using thread lines. It is a pleasant high-wing, slabsided sheet covered model, solid wings of elliptical planform. Taking off from a concrete disc, Nancy has been through everybody’s hands as a trainer machine; used for change-overs in mid flight; made the stooge for two in the air at once; and even taught somebody’s girl friend (who is now learning to stunt!). Of all our stock, we think this is the model of which most of the original kit has survived. Main damage has been to engine mounting, and a new fuselage will really be a boon.

Another low-priced babe that we enjoyed, was Bournemouth’s NIPPER. This with most of their other kits is designed by Queen’s



Cup winner, Phil Smith, who can make these little chaps do most of the tricks. Last year at the Nationals (he was too modest to enter the Gold Trophy !) he gave a splendid show with this model, and did even better with his biplane STUNTER, and of course the twin-boom SPEEDEE. All these three designs are quite suitable for novices, who need not start with the stunts. Powered with anything over 1cc., however, they are quite hot and should be treated with respect.

Of the beginner-intermediate type, Henry J. Nicholls' MAGNETTE came along about the same time as our first E.D. Mk. III—a combination which proved most successful. First model completed was wiped off completely in a burst of over-confidence ; one or two parts salvaged went to make a second off that lasted quite undamaged longer than any. Half-a-dozen first "wingovers" were produced on the staff Magnette, now literally worn out. Built down to under 16oz. all-up weight Magnette will loop, at 13oz. multi-loop ; but we blush to confess our own specimen was rather obese—tipping the scales at 21 oz. With drop-off under-carriage, this heavyweight *did* manage to get itself safely out of a loop, but we were too fond of the old dear to risk it any more. For those who like an American flavour to their flying, we can best describe MAGNETTE as an original British version of Hot Rock style for 2-3cc. engines

International have produced a fascinating streamlined highly pre-fabricated kit, appropriately called the RADIUS. It is extremely complete, with preformed undercarriage—always a bugbear—and every part really fits where it should. For novice flyers, it has one

Worcraft Monarch—a robust job that we first flew in a near gale. \* Fitted with an E.D. Comp Special we got some quite sensational flying in before the inevitable. Moulded cabin was omitted as someone trod on it during building operations. Quite within the scope of the average careful beginner.

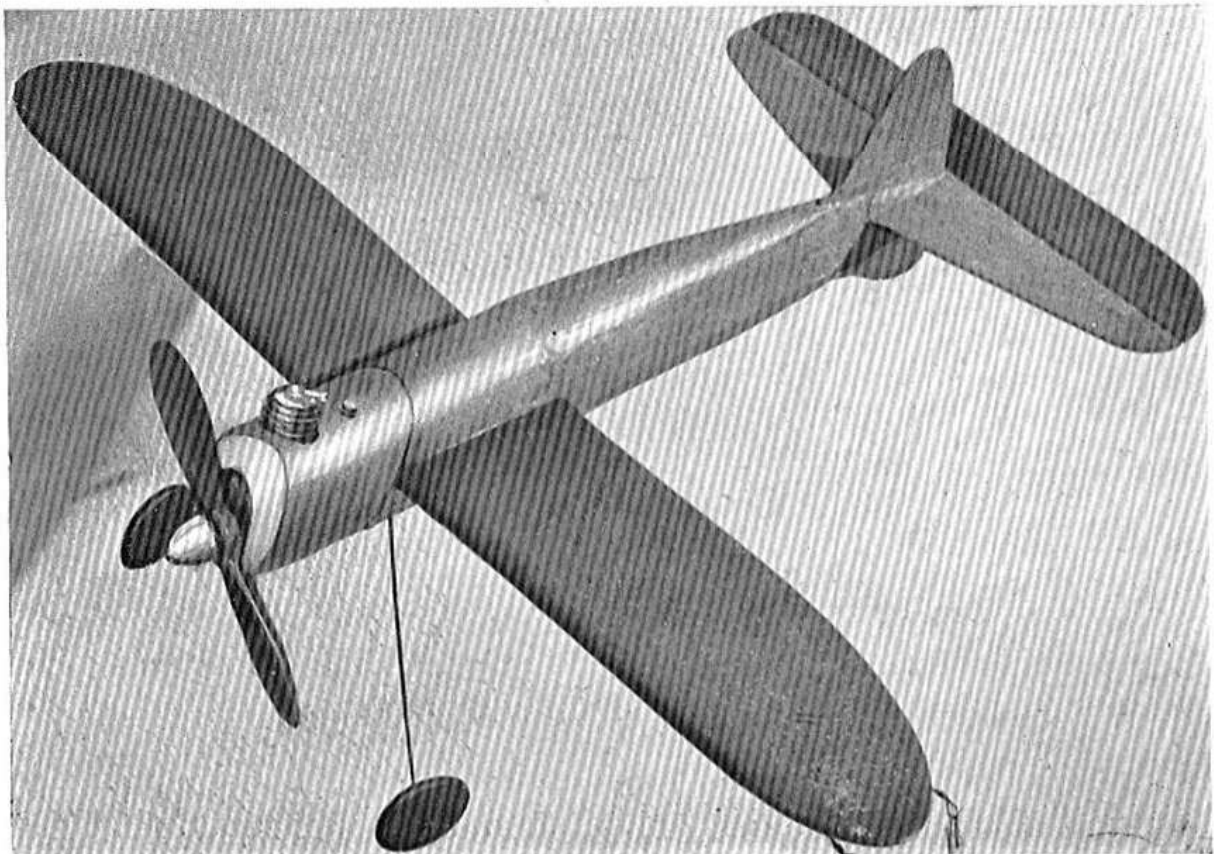

very successful feature, a knockoff elastic fixed engine mounting. Contrary to general usage, we cemented our fuselage halves together—instructions suggest they should be elastic fixed for access to control plate, etc., but cementing them in place makes for a more crashproof job. We cannot do the things the I.M.A. boys showed us half so smoothly as they do, but we can do them on our home ground, and suitably mated with a Frog 100, it is a good little machine. For those who want more urge, the 180, or the glowplug 160 can be used instead.

Halfax have a 'RAINER—it was one of the first British kits on the market, and so, not surprisingly, is somewhat outmoded today. Their supporters will not go wrong, however, on Trevor London's latest model, the SABRE. This is described as an advanced trainer and speed model. Fitted with a Mills or perhaps something less potent, it is an excellent first off for those desirous of joining the speed ranks. It gives good response to the controls, and affords splendid training from the start in dealing with a fully cowled-in motor. Then, provided it is still all there, the blossoming learner can fit a somewhat hotter motor and get it buzzing on the lines like a winner.

Those who fancy a dolly take-off and like the biplane layout, could do worse than desert the kit market for a plan—in this case, the A.P.S. TYRO TRAINER—a solid wing speed trainer biplane, intended for a 5cc. Drone diesel, but quite happy with an Owat, Micron, Delmo, or anything else about that size. We built two and really enjoyed the feeling of power and pull on the lines they gave. For those who may do likewise, we give this advice: be sure that the balsa used for the fuselage is really the hardest you can get. We did not take this precaution, and both machines broke in the same place eventually, just forward of the tail—once it occurred in mid-air; the audience

Veron's Speedee, a pleasing little twin boom that is still in flying condition in spite of use and abuse, as scars would indicate. Built for flying rather than looks, the J's tank mounted on the fuselage may offend the purist, but is just the thing for a quick take off in lunch hour circuits.

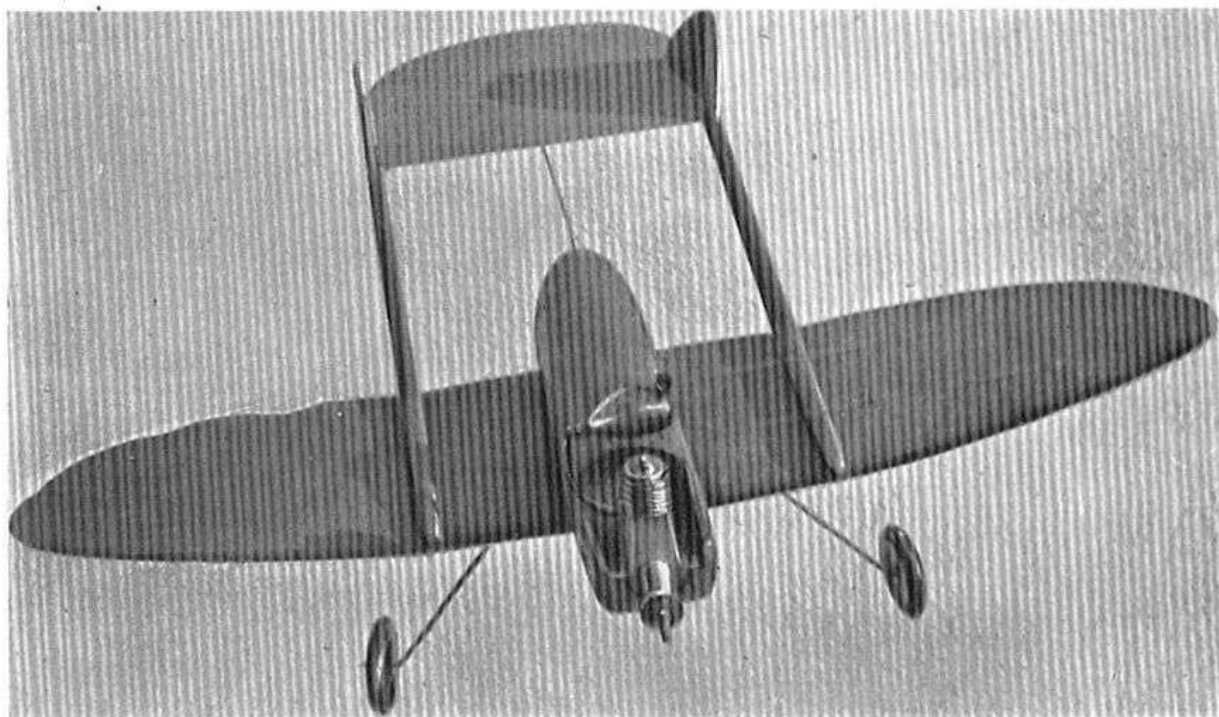

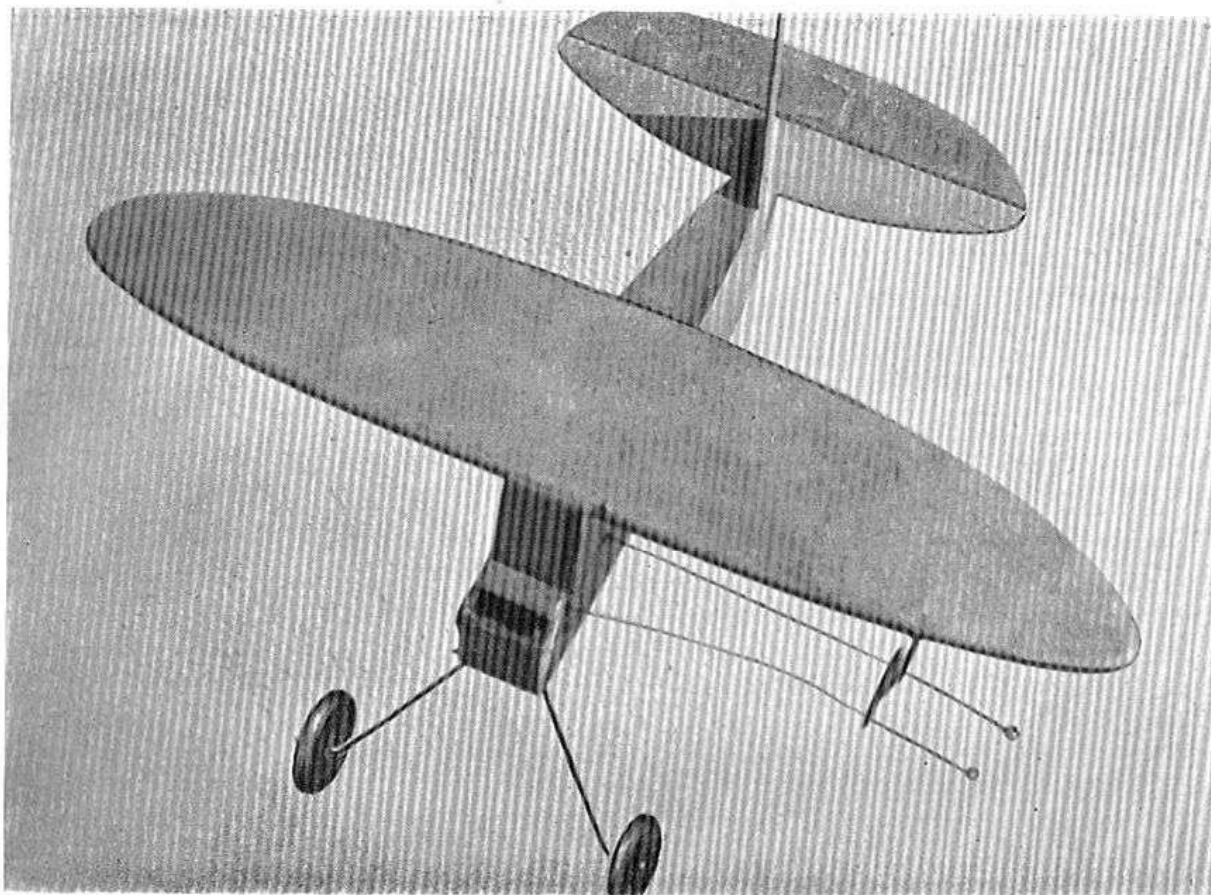

Original Nancy—with radial engine mounting showing signs of wear, but no other damage. This "baby" served as a first flight machine to many, including girls, and still lives to fly again. Just the machine to train an infant prodigy on—or to last a full season in more careful hands.

was respectfully silent; we were not. This machine will provide a regular course in speed apprenticeship—top somewhere about 70 m.p.h., good cruising at 50 m.p.h., and fixed undercarriage, drop-off wheels or standard three-wheel dolly can be used.

Worcraft's MONARCH is another simple job for a start—though for an absolute beginner, we would recommend fitting of rather stouter engine bearers—or perhaps we were just unlucky. The Don RIVAL is another extra simple model that seems just made for the beginner, without structural problems or flying difficulties. Some of Watkins' plan packs also make quite useful trainers—we have in mind particularly JINCKER and BAMBARA.

A lot of the beginner's problems will be centred round choice of a kit to suit an engine they already have. In this connection, do try to get a kit specifically designed for that engine, or that capacity. Putting a quart engine in a pint airframe, will be spectacular but short lived. There is no need to be nervous of making a start with a large engine—which means a correspondingly larger model. Such a model is, if anything, easier to fly than a smaller one, not so restricted by weather conditions, and gives more feeling of really flying. But if, or, should we say, when, it crashes, it hits that much harder.

Those without either engine or kit, and so able to get the two together, we would recommended to a middle course, of neither too small nor too large. There is a really grand selection of engines between 2 and 3.5cc., and matched kits to suit them.



Gathering of speed merchants for the American Nationals. These flyers come from Honolulu, Cuba and Mexico, but are alike in the design trends shown. Note only one model has a fin, while that in the grass sports a butterfly tail, a style that is finding more and more support amongst the 120 m.p.h.-plus brigade.

## CHAPTER THREE

### DESIGN CONSIDERATIONS

**T**HE builder will not remain content with kits and other people's plans indefinitely. Sooner or later he will find the urge to design something for himself irresistible. Then what a wealth of opportunity opens before him! In the control line sphere there is literally no sort of aircraft he cannot build and fly, given skill and patience. Sleek speedsters, clever trainers, scale designs with one, two or three wings, old timers and modern, single engined or multi-engined, experimental flying wings, tandems, canards, pushers, stunters, jet powered 150 m.p.h. projectiles, they have all been built and flown by inventive control line fans. But, before coming down to specific types, engine sizes and so on, there are a few general considerations that should be known to the would-be designer.

One of the first points that calls for determination, is the moment arm. Are you joining the long moment arm school as exemplified in such famous models as Hot Rock, or do you favour the short moment arm, which makes for lightning quick responses to controls? Just to refresh our memories on the subject of the tail moment arm as it is properly called, this is, the distance between the centre of lift of the mainplane, which, according to the airfoil section used normally, lies 25-35% of the chord back from the leading edge, and the centre of area of the tailplane. Quite apart from any aerodynamics, it is obvious that the longer this distance is the greater will the lever effect be of any force exerted at the tail to move the aircraft about its centre of lift. This means, that a small elevator placed a long way back will do the work of a large elevator situated nearer the mainplane, and because the tailplane has a longer way to move, up or down, when executing a manoeuvre, the operator has more opportunity to see the effect of his control, correct it if necessary, and damp down the movement smoothly. Conversely, a large elevator placed a long way back will carry out the manoeuvres of a large elevator placed a short way back, but carry them out more slowly due to this long moment arm. This is one reason why it is usual to find super stunt models tend to a short moment arm and speed models, whose very nature demands smooth even control, require a long moment arm. This must not be accepted as a rule, or even a generalisation, but as a design tendency.

The moment arm cannot be indefinitely extended with improving results, nor immoderately shortened. There must be reason in all things. Speed models work well with a moment arm of from one wing span in length to a span and a quarter. With anything much less than a span's tail moment arm, flying conditions are likely to be tricky

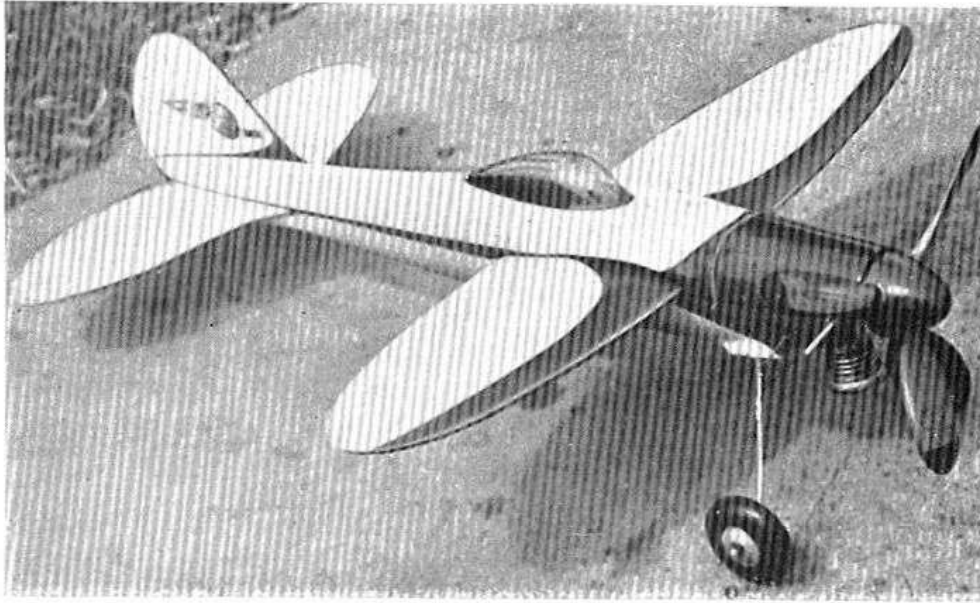

French intermediate speed model. Consideration has been given to looks in the moulded cabin and three blader prop, features that must be discarded when going for absolute speed figures.

with a phugoid—or hunting up and down—movement that, once started, will get worse until the model hits the ground. Scale models will have their moment arm fixed already at between one-half and three-quarters of a wing span, with one or two exceptions. As such, they will make good sports machines, sometimes excellent stunters, but not often successful speed models. Which may seem odd when prototypes have possibly been “fastest in service” in their day; but many service types were beasts to fly, and in asking say, 100 m.p.h. of a model Spitfire, scale speed is being exceeded manifold. Stunt models will usually be found in the lower tail moment range of scale models or even somewhat less, though here it is fixed by choice, and not by copying. A point to remember in laying out a design, is that fin area is affected by tail moment arm length in exactly the same way and should be adjusted accordingly, particularly where an offset fin is employed to hold the model taut on the lines.

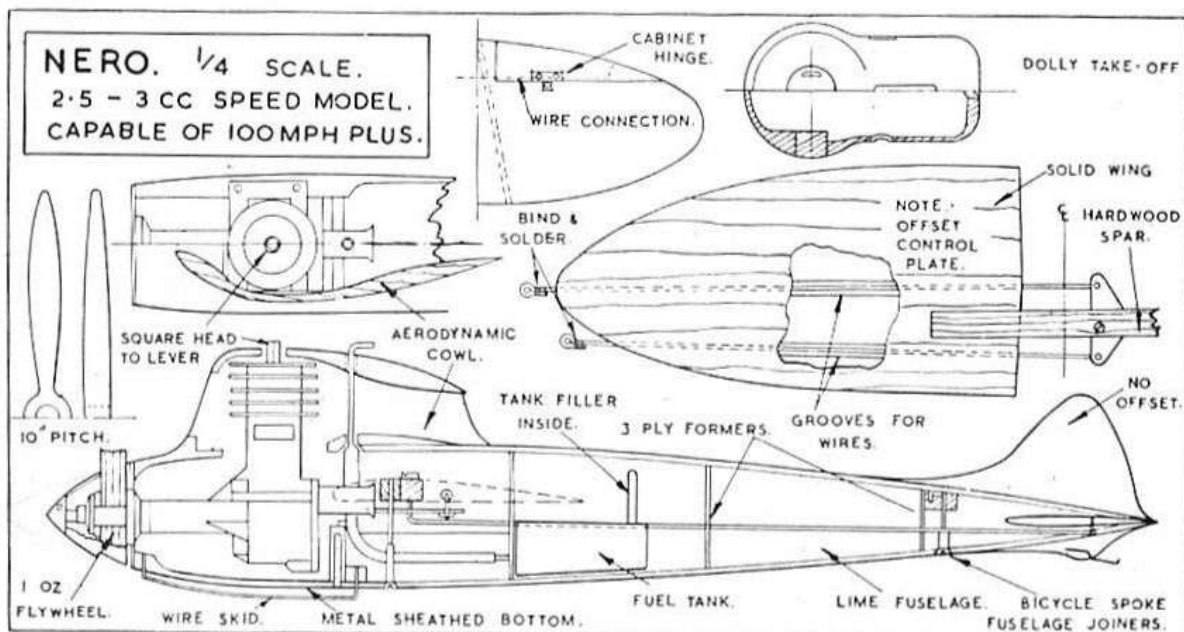

Tail areas are dealt with fully in the chapter devoted to them, as are the percentages of elevator area to tail surface, so we will content ourselves here by saying that areas range from twenty to thirty-five per cent. of wing area, of which any part from fifteen to over fifty per cent. may comprise movable elevator surface.

With the present swing towards diesel or glowplug types of engine, the problem of balance is important at the design stage. With spark ignition models, it is possible to be quite vague and indefinite and then trim to required point by shifting batteries. Without them to shift, it is necessary to add dead ballast which is always bad: better by far deliberately to add that weight as extra structural strength. Centre of gravity should be designed to lie in front of control plate pivot point so that forward control wire is on the C.G. Pivot point should be situated just aft of the centre of lift of the mainplane in the case of sports and stunt models. Speed models should locate their centres of gravity midway between the leading edge of the wing and its centre of lift. This will prevent any undue nosing up effect at high speeds. There is a growing fondness to lead out control wires in a slightly backwards pointing direction with all classes of models, so that wire guides in the wing are substantially behind the C.G. This is claimed to make for greater manoeuvrability, easier whipping and general handling. On those we have tried like this, the claim seems to be justified, it is after all a development of "whippower" technique.

Landing gears and take-off appliances are discussed in their appropriate chapter. The old free flight practice of considering the undercarriage as a form of protection for engine and airscrew might well be remembered in control line design. Anything that can keep a prop even one flight more, is to be considered!

American enthusiasts have split into two camps on the subject of stunt models. The Californian group go in for large fast models, flying at speeds of from 70-90 m.p.h., powered with 10cc. engines of the Super Cyclone type, and do their flight patterns at flat out speeds. Very nice and very spectacular we agree, if you have the engines,

Imposing array of contest models—brought to a competition by two American flyers only! This mass production enables pre-contest practice on a hundred-per-cent scale and is general amongst top-flight men.

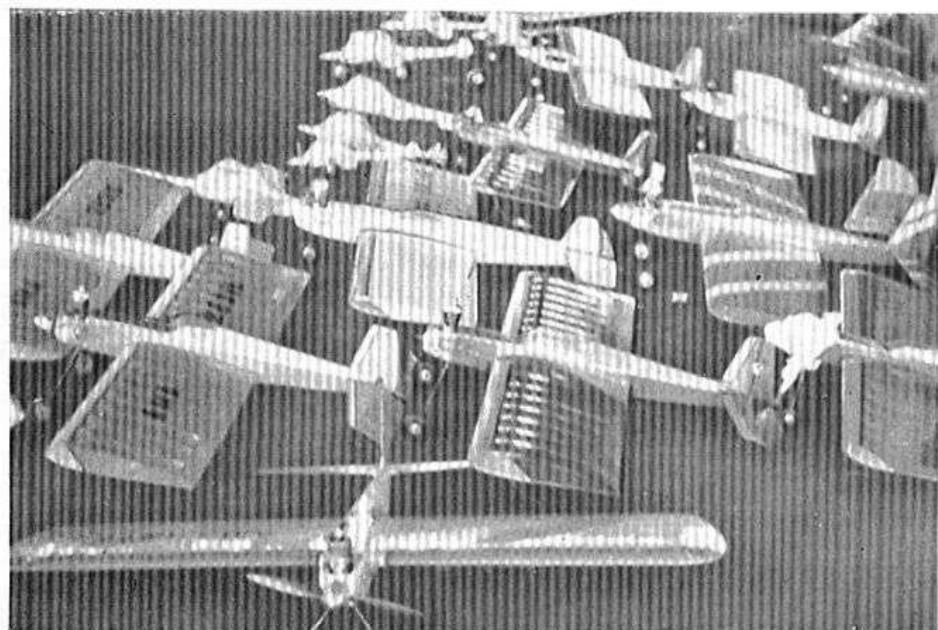

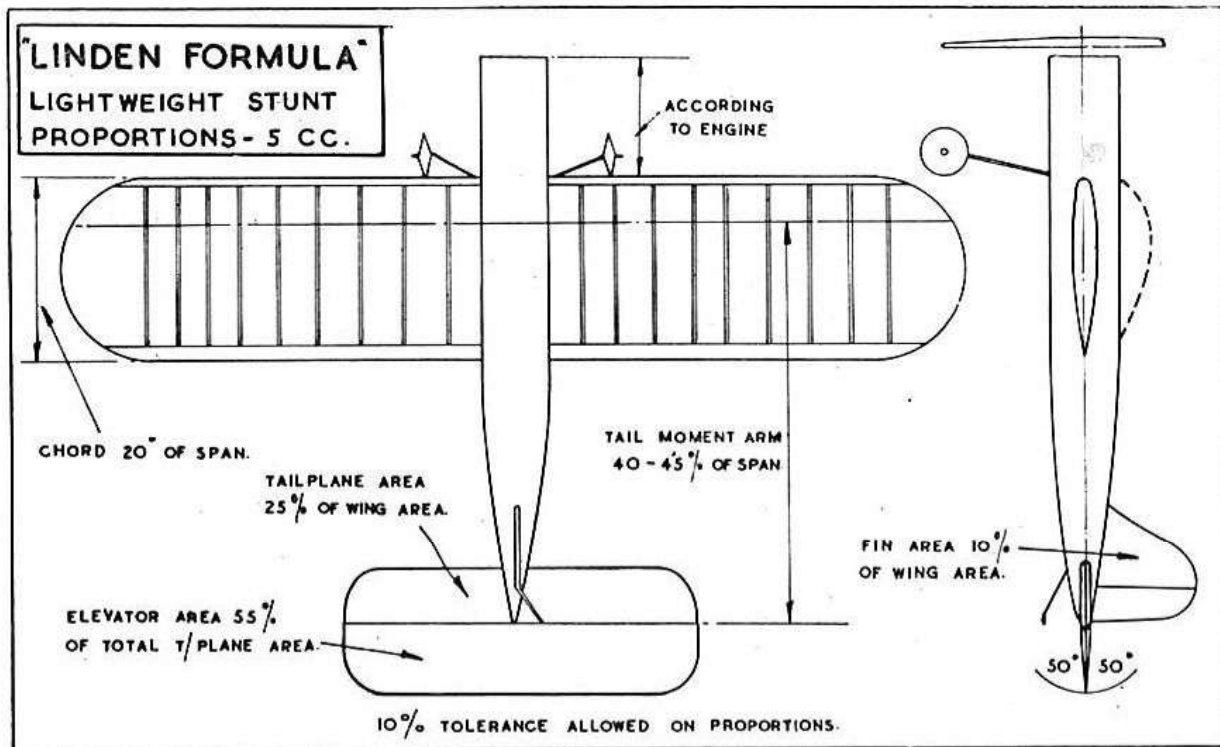

and the luck to keep everything in one piece. In this country a somewhat toned down variety of this technique has been developed amongst West Essex club members, including such excellent performers as Dennis Allen, Henry Nicholls, and many other up-and-coming contest flyers. Equally of course, the West Essex boys have in their midst a small slow school of thought which has produced one or two notable miniatures featuring Mills and similar engines.

Most British control line flyers, however, will be concentrating on the up to 5 cc. class and for their benefit we publish findings of the Eastern group of American experts as exemplified by the Linden M.A.C. For the record we would mention that young Dave Slagle, won the National Stunt Championship in '46 with a large size fast model, while in '47 Bob Tucker's Hot Rock—small power slow speed—won the day. Linden M.A.C. made a careful study of all their successful stunt models, built during 1947 and powered by motors of up to 5cc., mainly Drone diesels, which are virtually "non-utility Microns," and came to the following conclusions:—

(1) Wing section should be perfectly symmetrical, maximum thickness, one-third back of one-seventh chord thickness (14.3%).

(2) Wing and tailplane incidence 0°, and to be located on the thrust line (5% tolerance allowed for constructional reasons).

(3) Stunt tank essential, placed as near the engine as possible (i.e., short feed line) and—most important—on the same level as the carburettor intake.

(4) Elevator movement to be 50° up and down.

(5) Maximum effective weight for 5cc. diesel engine, 28½ oz., all up ready to fly.

On the subject of speed models, it is difficult to write. The expert will have already progressed so far that our advice would be



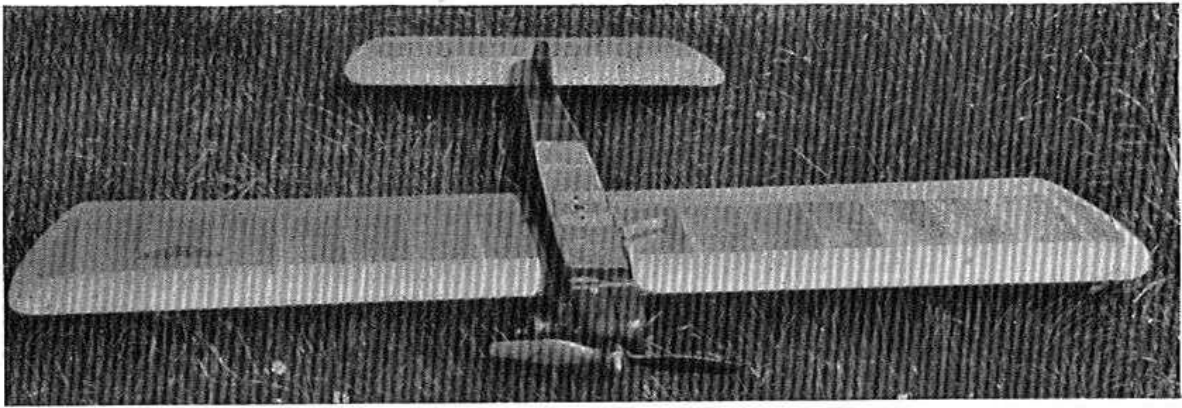

Typical British stunt trend of 1948. Model shown is Dennis Allen's Box-car with which he was unlucky not to achieve top marks in the Gold Trophy.

superfluous, while the less skilled will, no doubt, have grasped the obvious truth that the quest of speed is twofold: first, get the best engine available, then build the ideal fuselage round it. The rest depends on making the best engine just a little hotter, either by an improved fuel mixture, or by—dare we say it—tinkering with the works. If the tinker knows what he is doing, there may be a suitable improvement, if not, far be it from us to encourage him to even lift the pot! There remains then, only the actual airframe on which we can presume to guide the seeker after high speed.

Writing in *American Air Trails*, noted speed and stunt designer, Henry de Bolt, contends, "it requires as much designing and even better workmanship to turn out a contest winning speed control-liner, as it does to produce a free-flighter of equal calibre." He goes on to refer to the days when the smallest and sleekest good 'un would always beat another good 'un, that was just that much bigger, but maintains that, nowadays, models are already built round engines in the smallest possible sizes and that design itself will now decide the future winners.

Mills and E.D. engined stunt models by Mike Booth and Jim Gregory that showed up well in 1948 contests. It can be seen that a stunt model need not be ugly to perform.

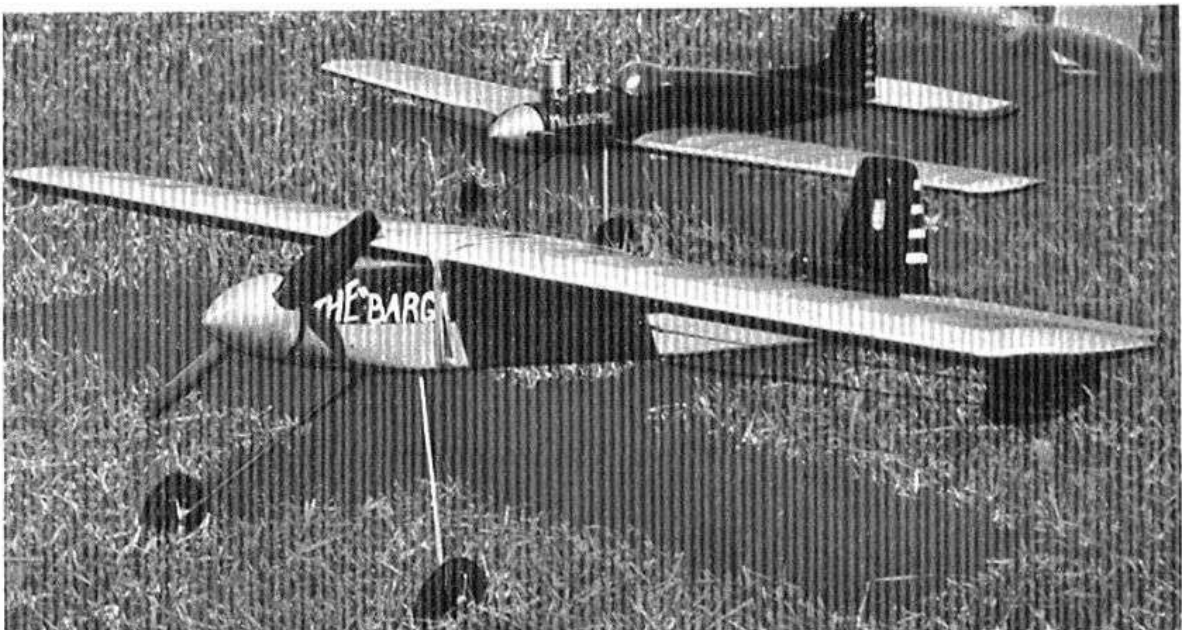

He speaks, of course, of *American* progress, it is probable that we have still a year or two of making them smaller here to be gone through before we reach the ultimate. Meanwhile, everything that can reduce drag will put up speed. For example, if you are flying with an offset fin to keep the model out, there is not only the drag of the actual fin, but the whole model is crabbing slightly, if only a couple of degrees. At reasonably high speeds, centrifugal force and torque should be amply sufficient to keep the lines taut, so that the whole fin can be omitted! Again, the slavish cowling in of the pot is all very well, but have you left a vent for the air to get out again after it has cooled the cylinder head? And what sort of shape is this airflow, does it really help or retard progress? Then again, would the engine set as a sidewinder, with the cowl faired into the wing be a lower drag proposition? Some of these problems are dealt with in a following chapter on engines, but strictly speaking, they can equally well be considered as points of design. Finally, is that fuselage smooth as the lines of a modern car and just as highly polished—or must we blushingly confess, it belongs to the treacle factory school? Any and every model we have yet seen produced for speed flying—with one exception only, that we do not propose to name—could be boosted up at least 5 m.p.h. and probably more by an evening's careful thought on its streamlining, and several more evenings' work making it *really* smooth! The effects of streamlining begin to be felt at 70 m.p.h. and upwards and as soon as you are in this speed range you must look after them with ever-increasing attention.

General considerations being duly discussed, let us get down to specific cases of designing control line models. As we have already noted, there is a wide variety of choice of kind of model—which can again be divided up into size of model. Any one of this wide variety can be made with engines of anything from under 1cc. up to 15cc., or following the S.M.A.E. classifications in any one of six size classes. The average enthusiast, however, will not do much running up and down the scale; having obtained an engine or two, he will soon discover his favourite size and build most of his models around it. Which is a wise decision and will produce specialist knowledge of what is likely to happen to any project almost from its inception.

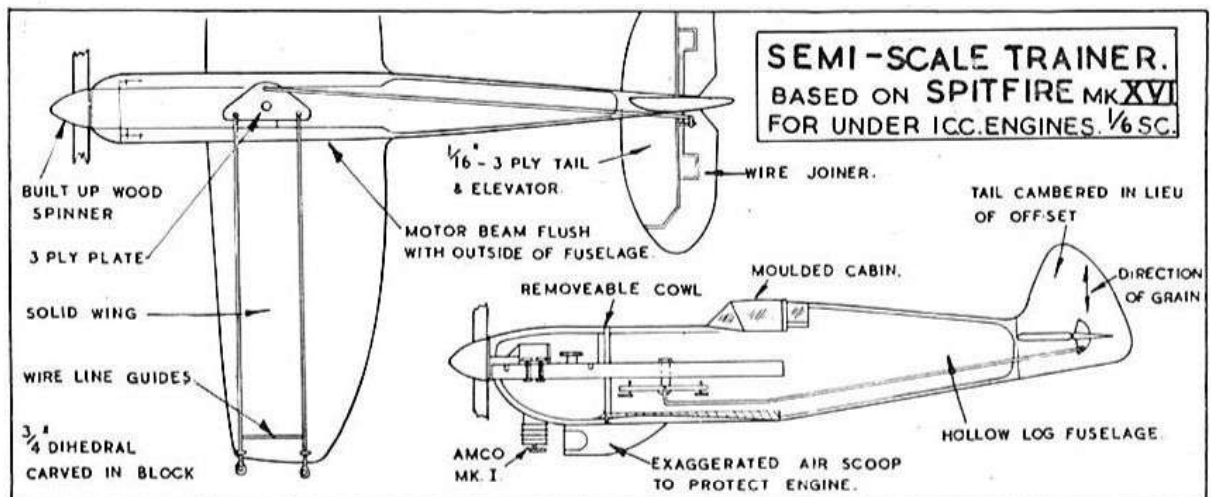

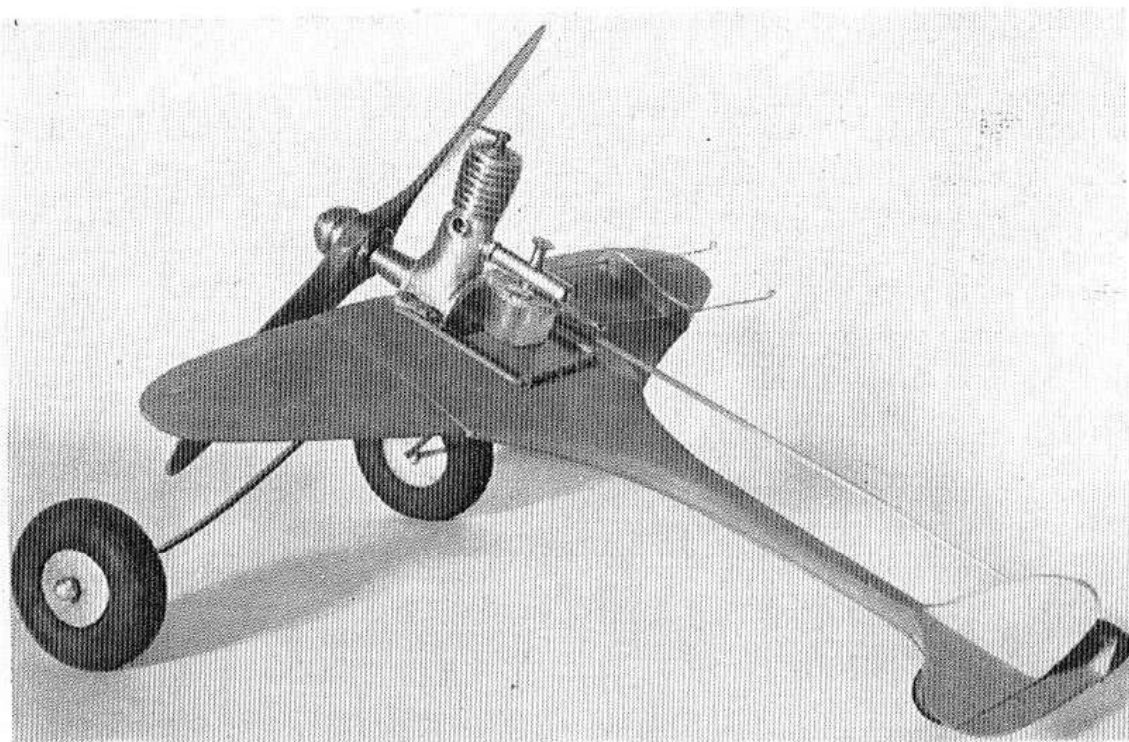

The Hundleby Kipper Mark I—a monstrosity based on Garami's Flounder that caused a lot of amusement, and finally even managed to fly passably well. Engine fitted is a Foursome 1.2 cc.—but it has been flown with a 5 cc. engine!

Starting at the bottom, and considering our own favourite pastime of building all shapes and sizes of Spitfires Mk. I—XXII, we offer a half-inch to the foot scale version of the clipped wing Mk. XVI. This was laid out (from enlarged 1/36th scale drawings) as a faithful copy of the original in side elevation and plan. There seemed no reason to change anything. Undercarriage was enlarged and moved forward for the initial model, but afterwards discarded altogether and flown hand-launch. This made a better flyer and a hundred-per-cent better looking aircraft. Hollow-log construction (q.v.) was employed, with the engine bearers set flush with the outside of the fuselage for reasons of space. Power unit was originally an Amco .87cc., which fitted the scale exactly. Subsequent changes to Mills 1.3cc. and Clan .9cc. gave faster flights in worse weather, but destroyed any scale appearance. Original camouflage colours were too good, as the model became unsighted against trees and so on in dull weather and our favourite "Fire Engine Red" colour went on for practical reasons. Purists, who like Spitfires too, could choose photo-reconnaissance types and colour them official blue. In use, certain original details were modified. Standard tank was small, awkward and inaccessible, so a larger celluloid one made with extension filler. Hinged cowling, that split along the centre line, and hinged back about the engine bearers, was replaced by a one piece clip-on type, as it tended to be caught by a careless finger when starting up. A solid former was inserted aft of the engine to protect interior of the model from fuel spray, which was rotting it. Later a larger three-quarter inch to the foot version was built, which took the Mills 1.3cc. without it looking and being unscalably large. This went faster and better, but did not have the same attraction as the smaller machine.

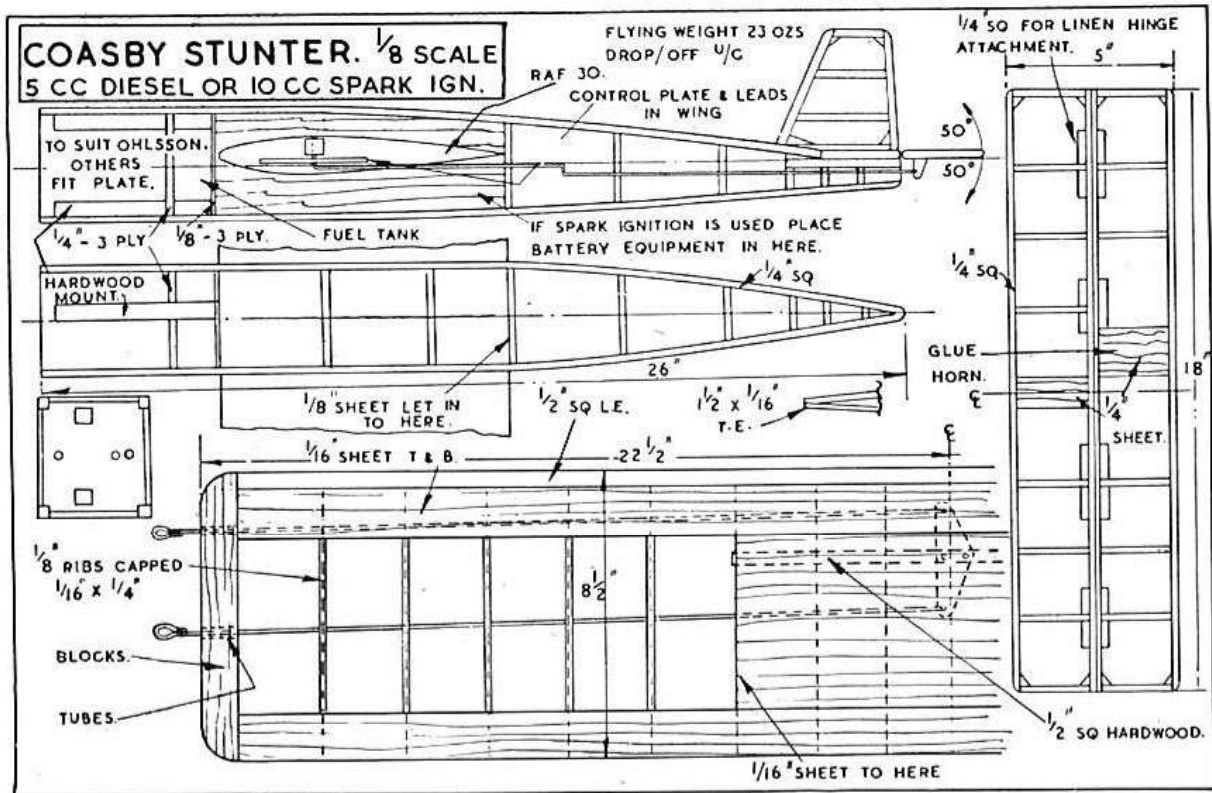

Sight of Garami's rudimentary "Flounder" in an American magazine encouraged Assistant Editor Hundleby to produce a similar horror called "Kipper." In spite of staff's unkind captioning, an illustration in the *Aeromodeller* brought a number of enquiries from would-be builders, and a number of words of praise. As a matter of fact, after it got over its teething troubles, it went very well and served as engine test bed for engines from 1-5cc. We will not speak of flying it with the largest of these. First trouble was too small a tailplane and too short a moment arm. It required nearly full up to get it off the ground, which had to be maintained to keep it aloft. Next was its habit of shedding a fin in every rough landing, and splitting its thin fuselage in twain. All these faults were met and remedied. The drawings here are of Mark IV Kipper and will provide a serviceable, cheap model.

Fascinating ghost model in "perspex" and dural tube. In spite of its uncanny appearance we are assured that it is capable of fast smooth flight in its designer's hands.

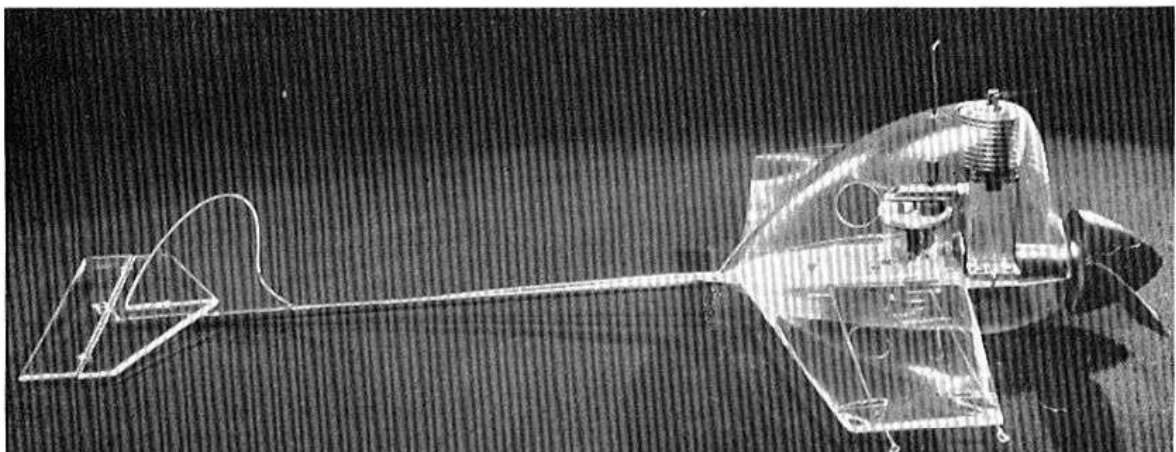

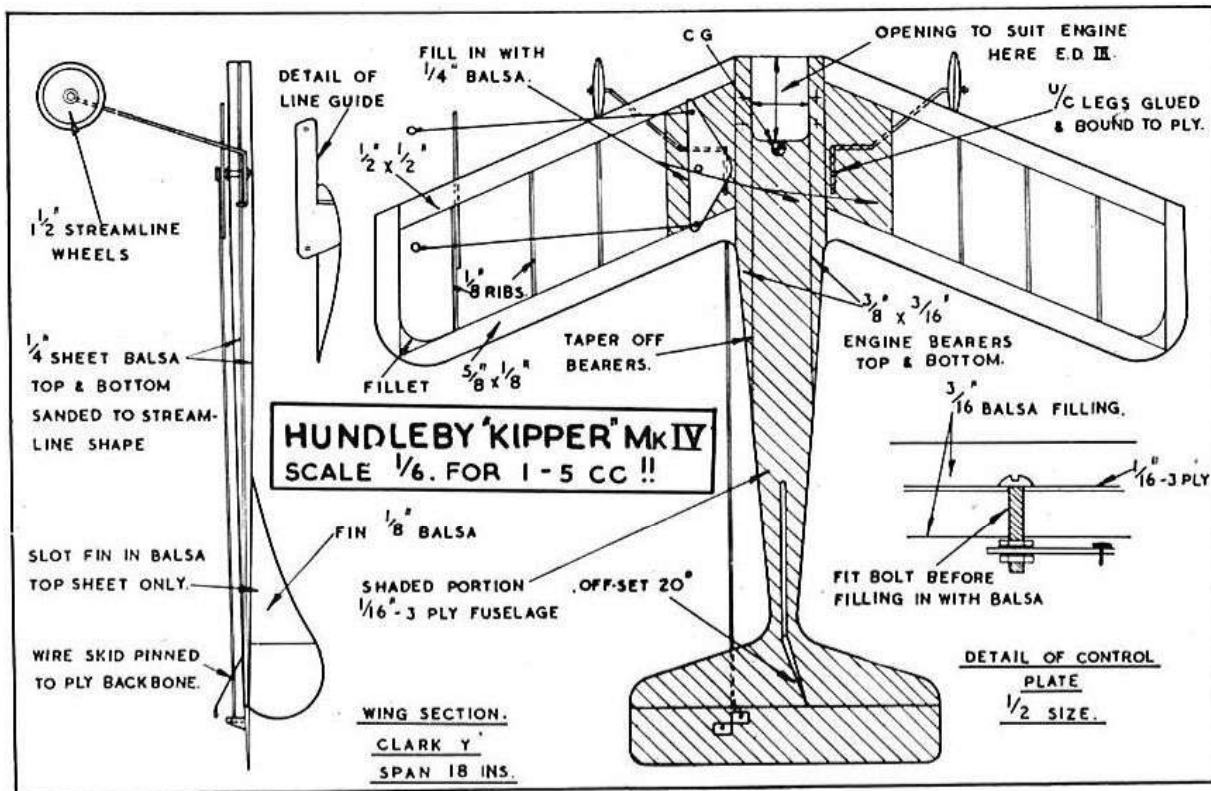

Several larger models for 10cc. spark ignition and 5cc. diesels, were developed after finding Ted Buxton's "Barnstormer" so pleasant a model to fly. Shown here are G/A drawings of J. W. Coasby's Super Delmo powered stunter, which put up some surprising performances. On one occasion, lines snagged immovably in a loop, model continued looping—three in all until the last just failed to clear the ground.

We have considered so far only four general classes of model: scale, stunt, trainer, and beginner's model. Speed is not a really suitable class to explain by example. As already noted, it is simply a question of getting the best streamline shape and then getting it better over a series of only, perhaps, slightly better, almost identical designs. There remain a host of other interesting models that involve no particular hazards to precious motors or spectacular crack-ups in the cause of science. An early unorthodox layout that will appeal for its prop-saving qualities is the pusher.

In this case, main source of trouble is procuring a suitable airscrew for a motor that will run in only one direction—if it runs equally well both ways, then a normal tractor turned round will do the trick! Usual trouble with pushers is to get at the engine to start it—twin booms seem to get in the way, and prevent the removal of fingers at the crucial moment. Alternative is to build something on the lines of a flying boat power egg, when boom trouble will not arise. This tends to be somewhat high up in case of a normal model, and will therefore be dangerously liable to turn over on its back and still break those props.

We have also tried, in company with P. R. Payne, a number of experiments with canards. Here some quite amusing problems arise with regard to the proper attachment point for control plate and con-

sequently lines. The theoretical C.G. has not proved at all the right place. The models we have tried have all required considerable ballast forward, and a line location well behind the C.G. Only with a nose-heavy machine did we find it manageable in the air. We are by no means satisfied that this is rightly so and, as opportunity offers, will have further trials with this layout.

Another very attractive control line design is the tailless model. That well-known American enthusiast, C. Hampson Grant, has published several of his successful designs along these lines, and they offer some really exciting flying. Contrary to the opinion of many, American designer Charles Cole, declares tailless models excellent for beginners, as they are almost impossible to ground loop, and take off and fly by themselves. Either pusher or tractor arrangements are practical, though the former is recommended, as the usual tailless sweepback to bring C.G. forward of C.L. adds to longitudinal stability. This increases constructional problems somewhat, as the two separate elevator surfaces must be linked together. As a general rule, it would be as well to build some tested tailless design before branching out with original models as there are a number of problems peculiar to them.

Many will also follow the growing trend towards scale models. Nothing could be pleasanter. Any number of plans are available of both modern and old time aircraft and there should be something to please everyone. We note that in France, the control line clubs have just announced a special contest for "historic scale models," by which is meant those, to us, peculiar machines dating back to the days of Bleriot, Ader, Santos-Dumont, Deperdussin, Wright and others. We feel that such enterprise is to be encouraged, and trust the venture receives the support it deserves. Some of these slow flying "vintage" models would lend themselves excellently to small and even ultra small diesel operation. How about a .2cc. Antoinette wafting gently round a circle in the drill hall?

For those who want speed and more speed by the easiest route, the new British versions of such American jet engines as the Dynajet and Minijet, will be welcomed. These engines have now been banned, quite rightly, for free flight, but may still be flown on control line. They are definitely not for the chicken-hearted, or for novices, and should not be flown unless the operator attaches the control handle to his wrist with a safety thong.

When laying out a design, it is as well to remember that anything directly in the way of exhaust gases will quickly be burnt. Tail surfaces should therefore be raised well above the jet orifice, or the jet pylon mounted on the fuselage. This high mounting which has been typical of first jet powered control line models, is not however, the ideal place. Fuel consumption is relatively high, and makes an appreciable difference to trim as the jet eats it up, making the model tail heavy. High mounted jets also tend to push the nose down when travelling really fast, to add one more worry to the anxious pilot in the circle.

Scale models of jet aircraft are possible and should give better

performance than freak layouts. It is practical to enclose the engine entirely in the fuselage, using the hollow log principle, or even a built-up fuselage, with a suitably large detachable section for getting at the works. Nimble take-off drill is desirable as the risks of the engine heating up are much increased whilst it is still on the ground. An airspace should be left round the jet tube, and the exhaust must be given free and adequate access to the open air. We learn that American enthusiasts have proceeded so far in their solution of jet powered problems, that they are even considering stunting such models!

Although the S.M.A.E. formula gives an extremely high wing loading for jet models, it should be possible to build them much lighter, within say the 1½lb. mark, without sacrificing looks or strength.

Those as yet without a diesel engine of their own, or unwilling to risk their precious possession on their first own design, may like to try their luck with a rubber-powered control line model. Construction can follow standard scale or semi-scale lines, with just a suspicion of a speed model, fuselage being well stressed to take a good supply of rubber, well wound up. Airscrew of hardwood should be comparatively small, and if the prospect of gearing is not too frightening, should be geared up say 2/1. Wings and tail surfaces can well be of sheet balsa, span up to 36ins., design proportions as set out for power models, but with torque compensated to some extent by an asymmetrically set wing. Dihedral is unnecessary. Release the model in the usual way, and fly with up to 30ft. thread lines. Duration will necessarily be as short as the motor run, but there is plenty of scope for amusement.

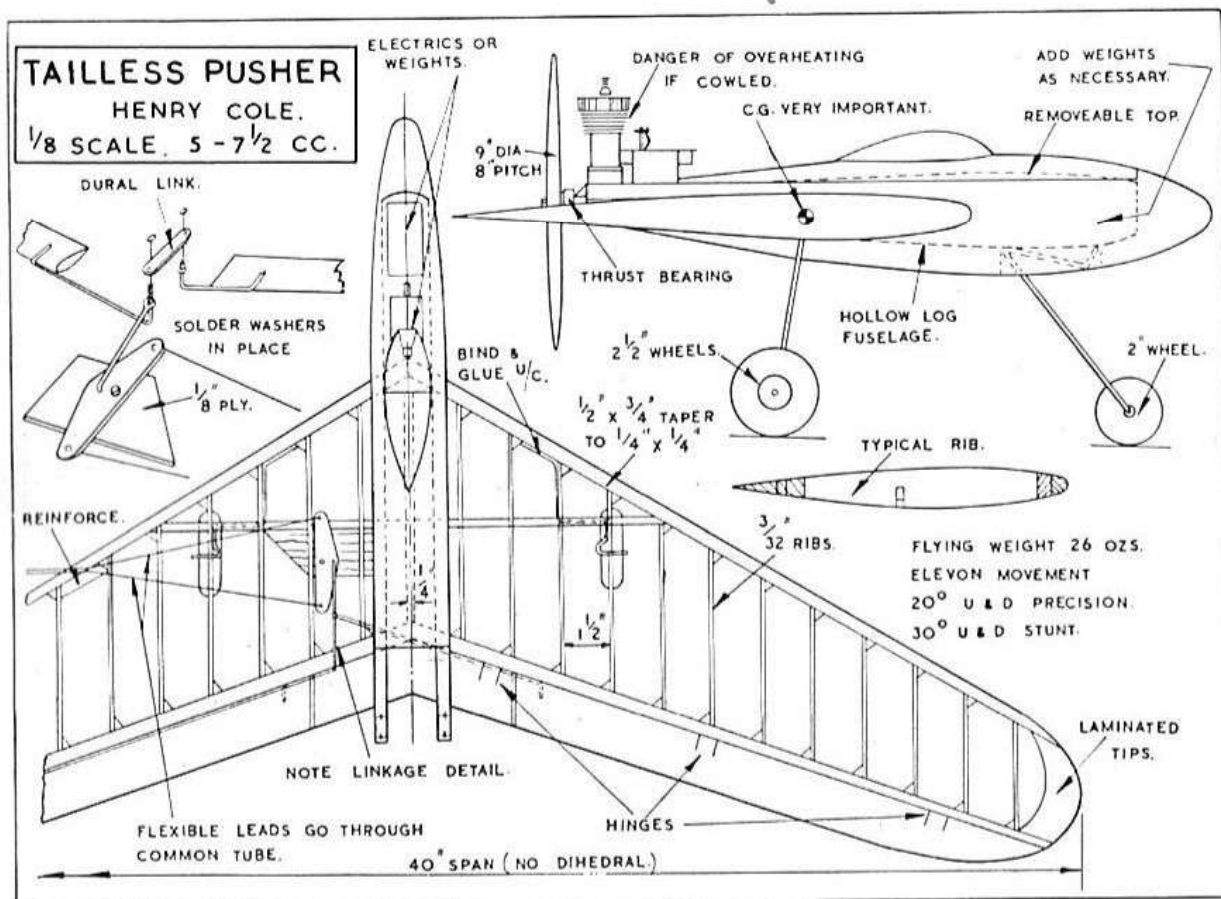

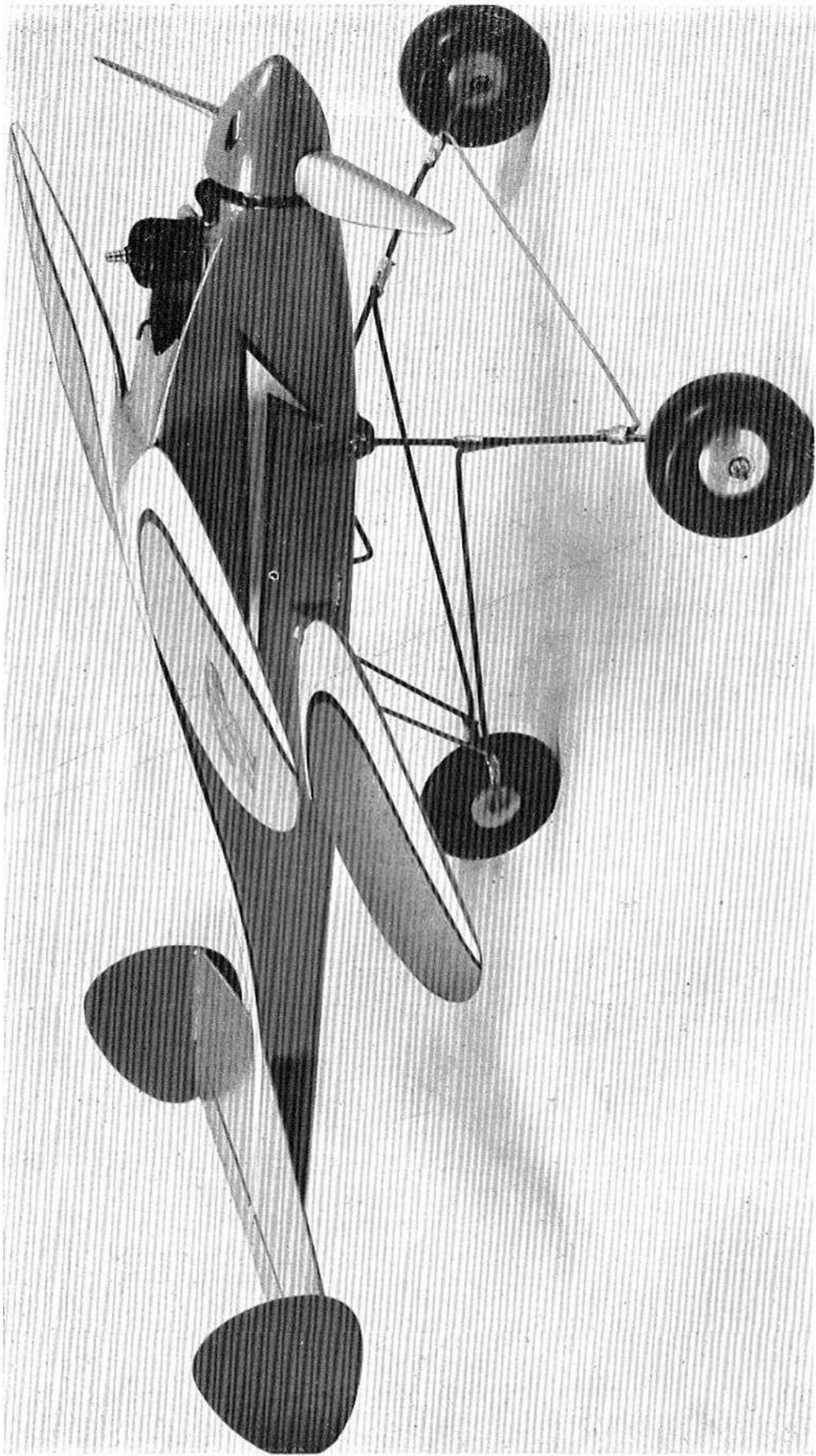

Tyro Trainer, mounted on tricycle dolly. This speed trainer features a sheet fuselage with  $3/8$  in. thick base to allow shaping at the nose and  $1/8$  in. top and sides. Using good hard balsa it makes up into a sturdy model that will stand any number of hard landings and ground loops off the dolly.



## CHAPTER FOUR

# THE FUSELAGE

THOSE considerations of added weight which may deter the builder from complete streamlining of free-flight models apply so little to control line designs that they may well be ignored. The only reasons that should legitimately influence the designer are those of simplicity, ease of construction and the time factor for any machine other than scale models where the prototype will naturally determine the ultimate lines. The fuselage in a model appears to have no real justification save as a convenient place on which to fix wings, tail and undercarriage at suitable distances and to house the engine and its accessories. Except in those experimental designs where it is airfoil shaped in the search for added lift it can by no stretch of imagination be said to contribute any useful aid to flight. On the contrary, it merely gives that insidious enemy, drag, one more component to help hold down the completed aircraft. It is logical, therefore, to so shape it that this holding-down moment is as small as possible.

This may seem a needless worry when elsewhere it is pointed out that no considerable amount of lift is necessary or desirable in a control line model, but a little thought will show that it is worth while. If the model is built for speed then every refining of the shape to reduce drag should be considered. For simpler models of the sports or trainer variety every reduction in drag gives that much more safety factor to the engine which has just so much more reserve power to pull it out of the unwise manœuvre, that sooner or later is always attempted. Non-technical types may like to know just what drag is. Without going into a spate of formulæ, it can best be described as the resistance set up by the various parts of an object to forward movement. Thus when cycling there is a noticeable increase in either speed, or the ease with which the machine is propelled, if the rider crouches down, offering as little an obstruction to the air as possible. This is particularly so when travelling against a headwind or at high speed. A similar effect obtains with a model aircraft, and as speeds rise more and more trifling obstructions create a serious degree of resistance or drag. Thus, an immediate increase in speed would be found by polishing a fuselage previously dull and rough.

Other authorities have already worked out relative drag figures for the commoner types of fuselage from which it appears that the round or elliptical fuselage has only about one-quarter of the drag of a square or rectangular cross-sectioned fuselage. While weight often prevents its use for any but larger models if strength is not to be sacrificed, it has

at any rate invaded the rubber contest field in the hands of such as Bob Copland, Warring and others. The built up fuselage, however, takes more time than a simple slabsider, and unless the design is very good adds little to the performance and can be just as easily lost out of sight. All of which piles up the agony against the round or elliptical fuselage, but does not apply in any instance to control line models; They can hardly be lost—their fate is usually to be written off in a last sensational prang. Here the question of strength crops up again. It is possible to build a fuselage that is so strong as to be virtually unbreakable in any but 100 m.p.h. crashes, and in this field it is hardly likely there will be a numerous following with the present range of engines. To solace the adventurer who loses his model in this homeric ending we can only pass on the practical advice of a leading American speed king who says, "then you sweep up the pieces and see if there is anything worth saving."

Easiest of all round or elliptical fuselages is the "hollow log" method of building. This, as the name suggests, consists of hollowing out a block of balsa or other wood to comprise the fuselage. Sometimes building instructions leave it there, and so many enthusiasts who might have been tempted proceed no further. It really *is* easy if a routine is carefully followed. First secure two blocks of wood as long as the fuselage and of just over either half the width or height. This makes a difference in the case of elliptical fuselages, as it may be desirable to divide them horizontally to make a lift-off lid or hatch to get at accessories

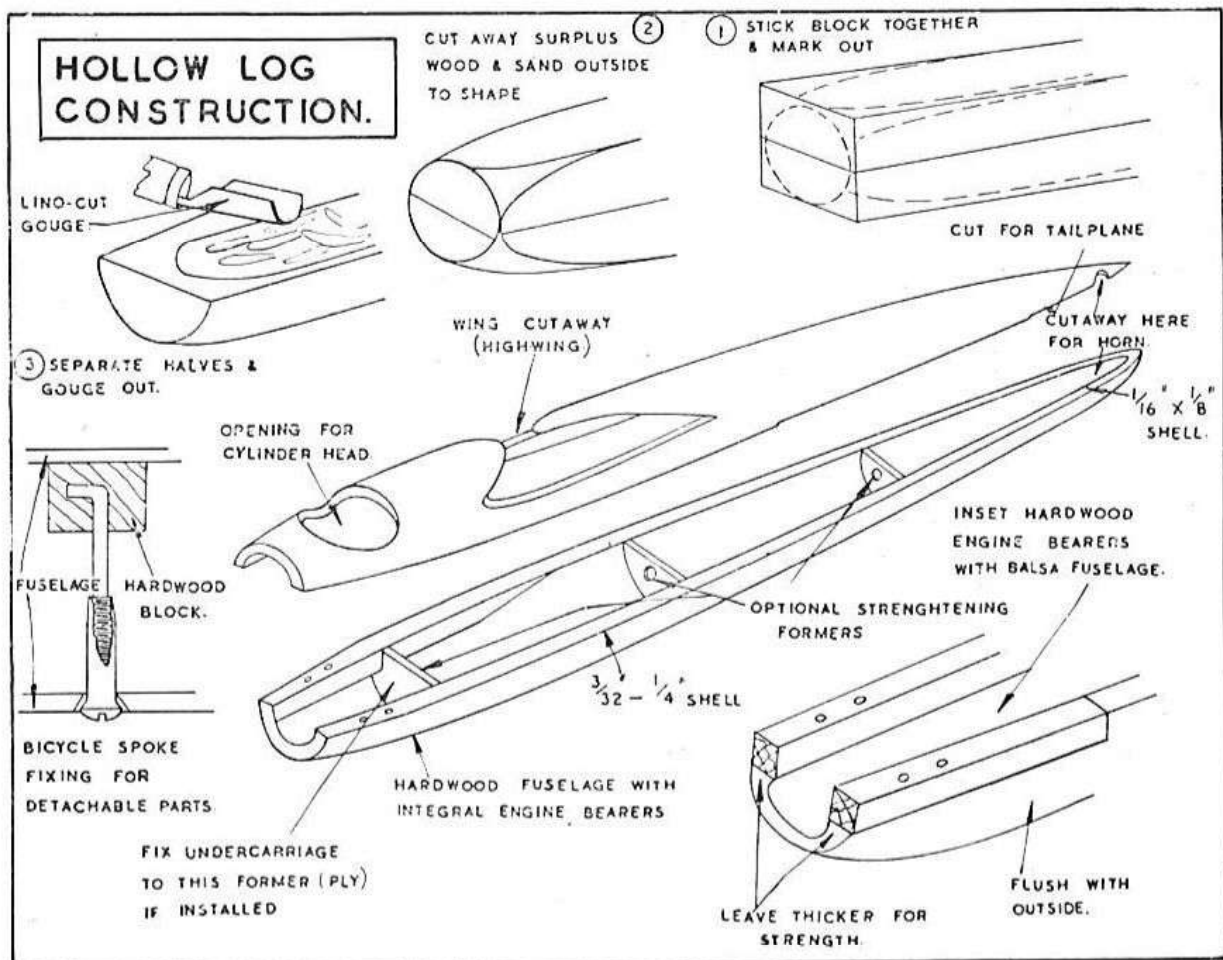

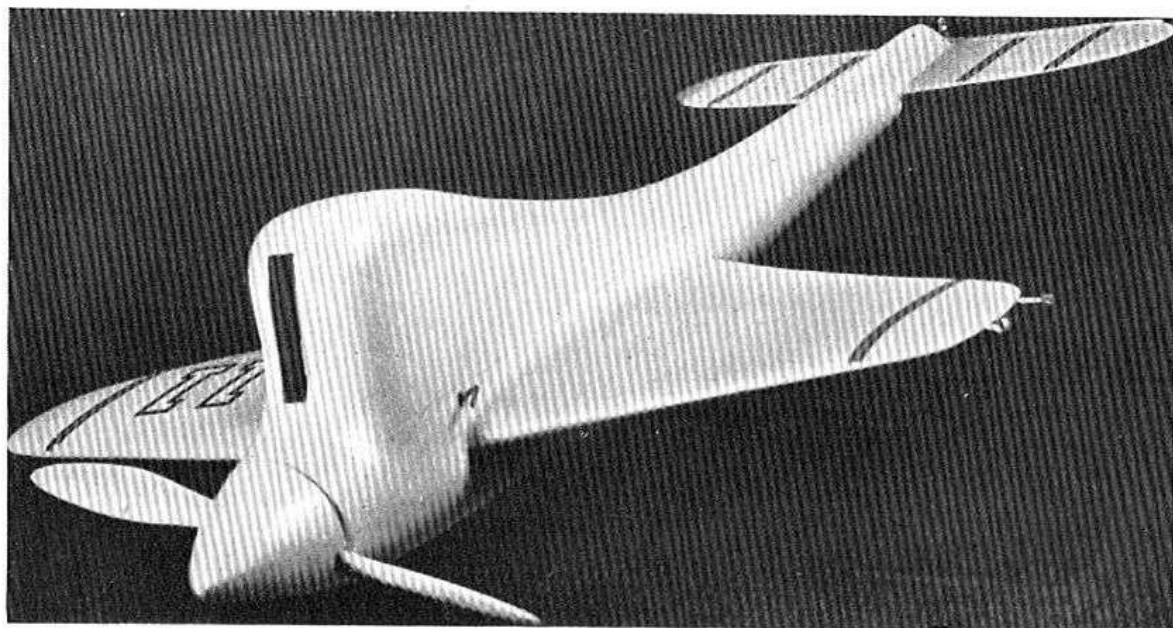

Another of Walter Musciano's pleasant designs—Speed King. This model follows modern practice with streamlined cowling, faired-in spinner and absence of fin. Fitted with a suitably powerful motor should be easily capable of 100 plus!

or controls. Here a little planning is helpful to decide the best place to split the two parts. With a truly circular fuselage the only thought is whether to split vertically or horizontally. Having decided this question, the two pieces of wood are lightly glued together to form a single block just a little larger in every direction than the maximum dimensions of the finished job. Some builders recommend that a sheet of thin paper is stuck between the two faces to make it easier to split them apart later, as will be necessary; this depends on how securely they are cemented together. Next the side elevation is traced on the appropriate side. It can be "pricked" through the plan and the pricks joined up, or traced outline stuck on. The lucky man with access to a bandsaw or jigsaw machine now has only to run the block through in a couple of minutes and his rough outline is done. For others a fretsaw, sharp knife, or even a razor blade must more slowly remove the surplus from each side. The plan outline is then marked on the partly shaped block and a similar procedure followed. The bandsaw man again will have the easier task for he need only replace one of the pieces he has removed with the plan outline traced on its flat surface and put the whole through the saw again. Others will have to take care in tracing their outline to allow for the new projected shape on the block. This work done, the block is finish carved, using templates as necessary and sanded to a smooth finish. It may then be split open and hollowing started. To hollow balsa with an ordinary woodworker's gouge is heartbreaking and almost impossible as with any but sharpest of tools the balsa is just torn. Attractive little sets of balsa knives and gouges can still be picked up for a shilling or two, or, failing this, any good artists' colourman will sell a set of lino-cutting tools for a similar sum. These tools are exceptionally handy for work of this sort, and we prefer them to more orthodox aeromodelling implements.

When hollowing out the interior be sure to leave adequate wood where wings and tail will ultimately seat down; for the rest a thickness

of about 1/8th in. is quite strong enough, going perhaps a little thinner towards the tail if lightness is needed there. It is unnecessary to finish to any degree of smoothness inside as no one will be seeing it, but clearance should be assured for any internal control wires, control plate and so on. It should be noted that a ply bulkhead for attachment of radial mounting engines will *NOT* be strong enough merely cemented to the end grain of the balsa, so that in all cases it is better to run through hardwood beam mounts to make a firm fixing. No apology is offered for this description of hollow log carving, as, in spite of its use for hundreds of thousands of solid models, the flying modeller seems, for some reason, to rather fight shy of it. Time for time it is nearly as quick as a box fuselage; certainly stronger and much better looking, and aerodynamically worth while on the score of efficiency alone. On the debit side is the higher cost of suitable blocks, but compared with the price of an engine this is trifling, say half as much again for the average control-liner fuselage, against the cost of a slabsider with sheeted sides.

This description has considered balsa only and permits the widest possible use of the medium to construct fuselages of either round, elliptical or compound cross-sections. A recent technique of advanced speed model builders has been to design their models with a truly circular hardwood fuselage of pine or similar wood. Instead of carving this laboriously by hand, it is rapidly turned to shape on a lathe, which in addition to fast production gives extremely accurate lines. Those fortunate enough to possess routing attachments can even proceed to the gouging of the interior by machine. Such luxury is not for the average modeller, but many should be able to turn up a fuselage to the outside shape, persuade a friend to do the job for them, or even pay a shilling or two to a local handyman for the work. Lest the enthusiast

A neat approach to the fuselage problem, with pod and boom, though likely to have a tendency to break its back unless the boom is reinforced with a ply backbone.

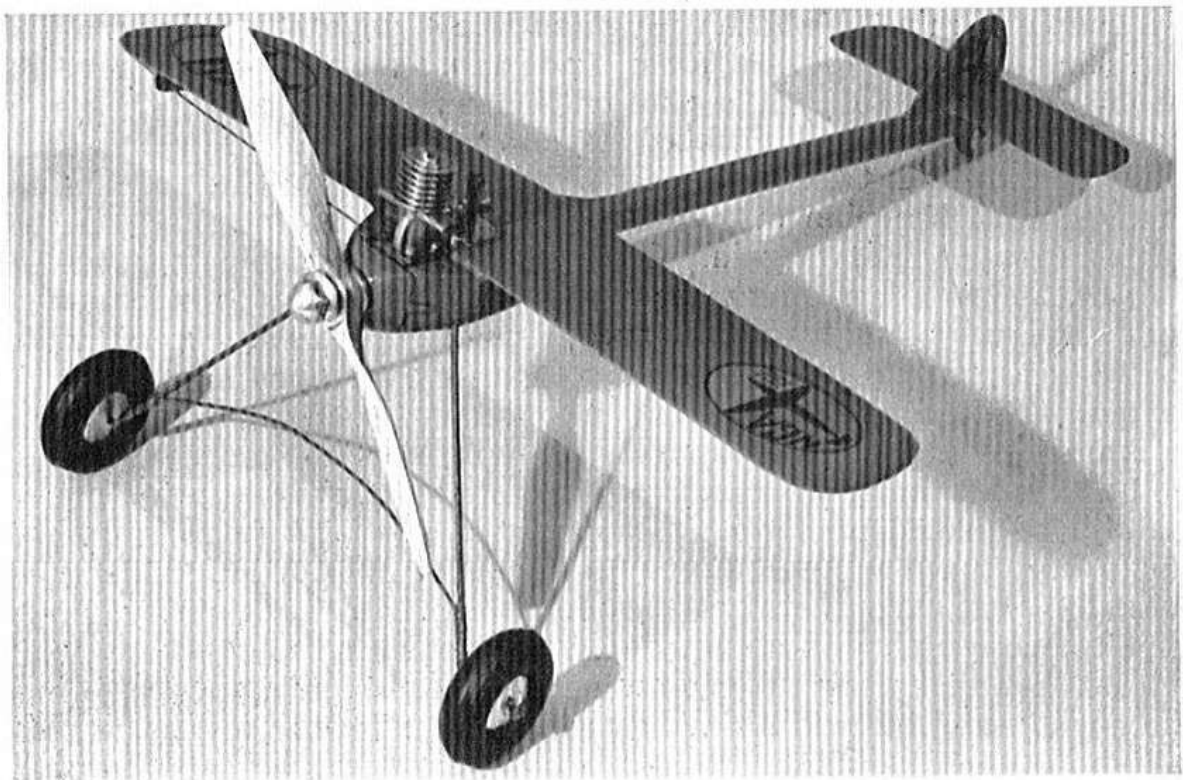

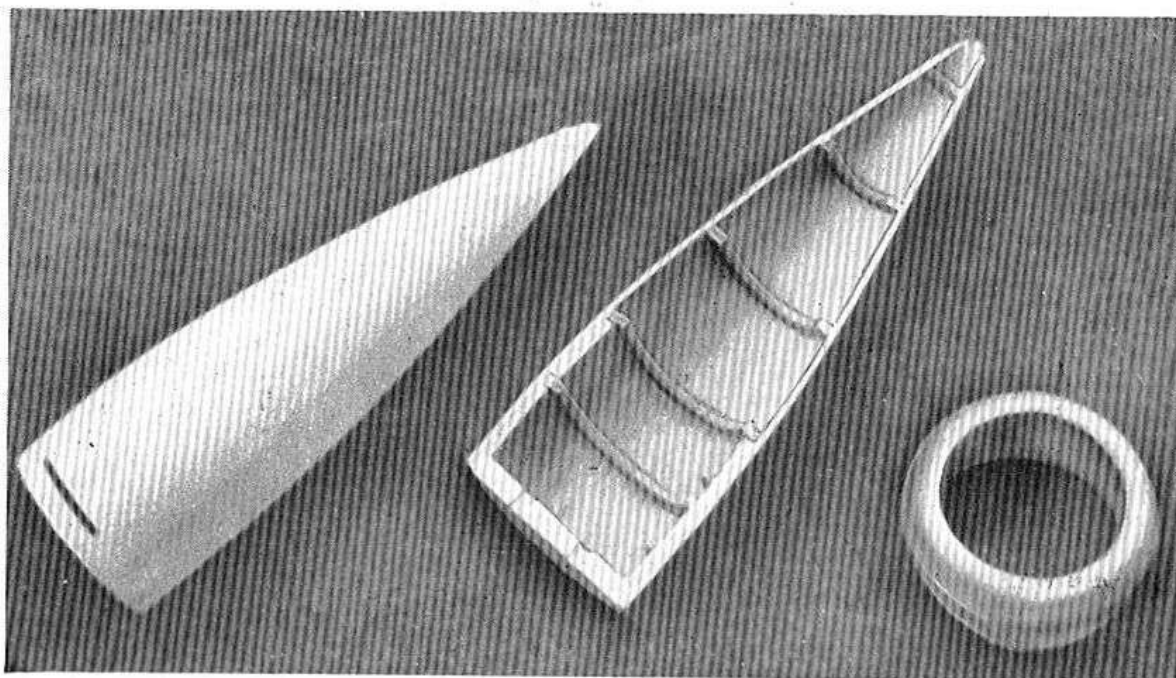

A built-up fuselage as featured in Astral's Hall Racer with half-round formers and medium sheeting. This makes an attractive model at lower cost than by hollowing out from block. Cowl on right is made from four segments cemented together.

wedded to balsa is rather appalled by this vision of unending work, we would mention that it is the common practice in Finland and Russia, where balsa is almost unknown, and pine the common medium, of carving sailplane fuselages, sometimes up to five feet in length, from such woods entirely by hand, and often in the most complex cross-sections. Such a fuselage will last indefinitely in spite of the most sensational disasters, and provide a rigid foundation for wings and empennage that will not warp or twist at the highest speeds likely to be obtained for very many years to come.

A derivative of the hollow log method that may be of some appeal is the well-established monocoque fuselage which gives an equally pleasant outline and opportunity for compound curves, but only at the expense of considerable labour and quite a lot of skill. It is doubtful if the resultant product is any better looking, has taken longer, is not stronger, and will be harder to repair in the event of a bad break.

A suitable, and practical alternative, is what can best be described as semi-monocoque, building up on a keel or keels, with a number of shaped formers, finally sheeting these over with soft 1/8th in., or, in the case of small models, soft 1/16th in. sheet. Such a design was followed with one of our own primary trainers that served as the test bed for a variety of engines ranging from 1.5 to 5 c.c. In spite of providing the first control-line flights ever for all and sundry, who showed little regard for its preservation as they had the comforting thought that "the firm would pay" for any repairs, it survived into honourable retirement. Every single part of this machine was damaged at some time or other, including the engine mounts of hardwood, with the solitary exception of the fuselage which remained to the end in its original state. Those desiring to follow this scheme should sheet in comparatively narrow strips going the full length of the fuselage, where

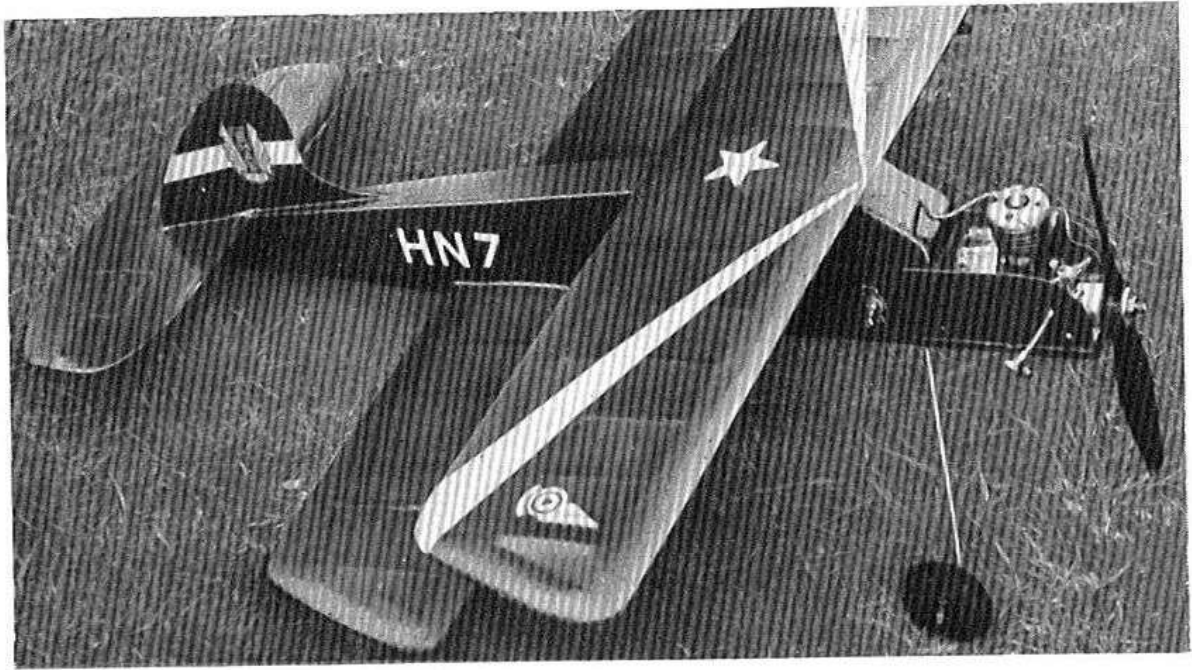

An early but successful effort by Henry J. Nicholls—his de Bolt Bipe which made a name for itself on the Television programme. All sheet construction will be noted, particularly the humped fuselage to make a suitable resting place for the upper wing.

practical, and not endeavour to do the job quickly with a few large sections. In this way they will ensure that every strip is adequately cemented to the formers. To be quite positive that this is so they should be pinned at each former along the length with either large glass-headed steel modelling pins, or the small half inch lill pins that can be bought at the stationers' in quarter-pound boxes. Some constructors find that these grip soft wood better, and on the sharper curves they can be forced right in to the heads. The holes they make do not matter as subsequent filler and sanding will dispose of them. The finished job should be lightly sanded and covered with grey filler or undercoat, whichever is easier to hand. Several coats are required with intermediate sandings until the grain no longer shows through. A final coat or two of the desired colour completes the work. It may then be polished with any of the special cellulose polishes or our old friend Brasso. For speed work every extra glitter may mean another m.p.h., so do not spare the elbow grease.

A point which is often forgotten or ignored in both hollow log and semi-monocoque fuselages is to block up the front part of the fuselages to prevent any exhaust liquid—so prevalent with diesels—being blown into the interior to cause deterioration and ultimate rotting of the structure. A ply plate will obviate this in the case of hollow log types, or with the semi-monocoque types a solid first former. Whether it is worth while lightening the others, except for the passage of control wires, is a moot point which must be decided on its merits in individual cases.

A neglected form of construction in this country that surely deserves a better fate is the favourite American crutch system. This ensures that the fuselage is dead accurate longitudinally, and forms a convenient base on which the main structure can be built. If formed entirely of hardwood such as spruce or birch it gives rock hard lines, and

the forward legs of the crutch can be arranged to form the engine bearers for beam mountings. Where balsa is preferred, hardwood engine bearers can be scarfe jointed into the rear balsa structure with nearly as satisfactory results. The crutch method is particularly suitable for petrol engined models which contain a number of movable extras in the shape of coil, condenser and battery, thus inviting a fairly large access hatch. Here is a firm fixing for this part ; it can be drilled for location pegs or form a strong seating to which hinges can be screwed.

In the realm of smaller engines a number of stick fuselage designs have been developed since the inventive Garami offered his peculiar looking "Flounder" to the American public. Here a substantial hardwood block forms not only the fuselage and engine bearer, but also the wing roots of the resultant curiosity. Aeromodeller Assistant Editor Hundleby produced his own version of this layout under the name of "Kipper," and provided considerable amusement with his heavily wing loaded midget, which proved immensely strong and *did* fly even in inexpert hands ! This reduces control line flying to the utmost " utility standard " and makes a model an evening a practical possibility. It is so ugly, however, that only the lover of freaks could tolerate it other than as an engine or airscrew test bed.

Whilst on the subject of the unusual, it is worth mentioning two other developments in the fuselage department. One is the cast electron or light alloy crutch, made up in the usual way from wood patterns. The resultant product is filed up, lightening holes added to

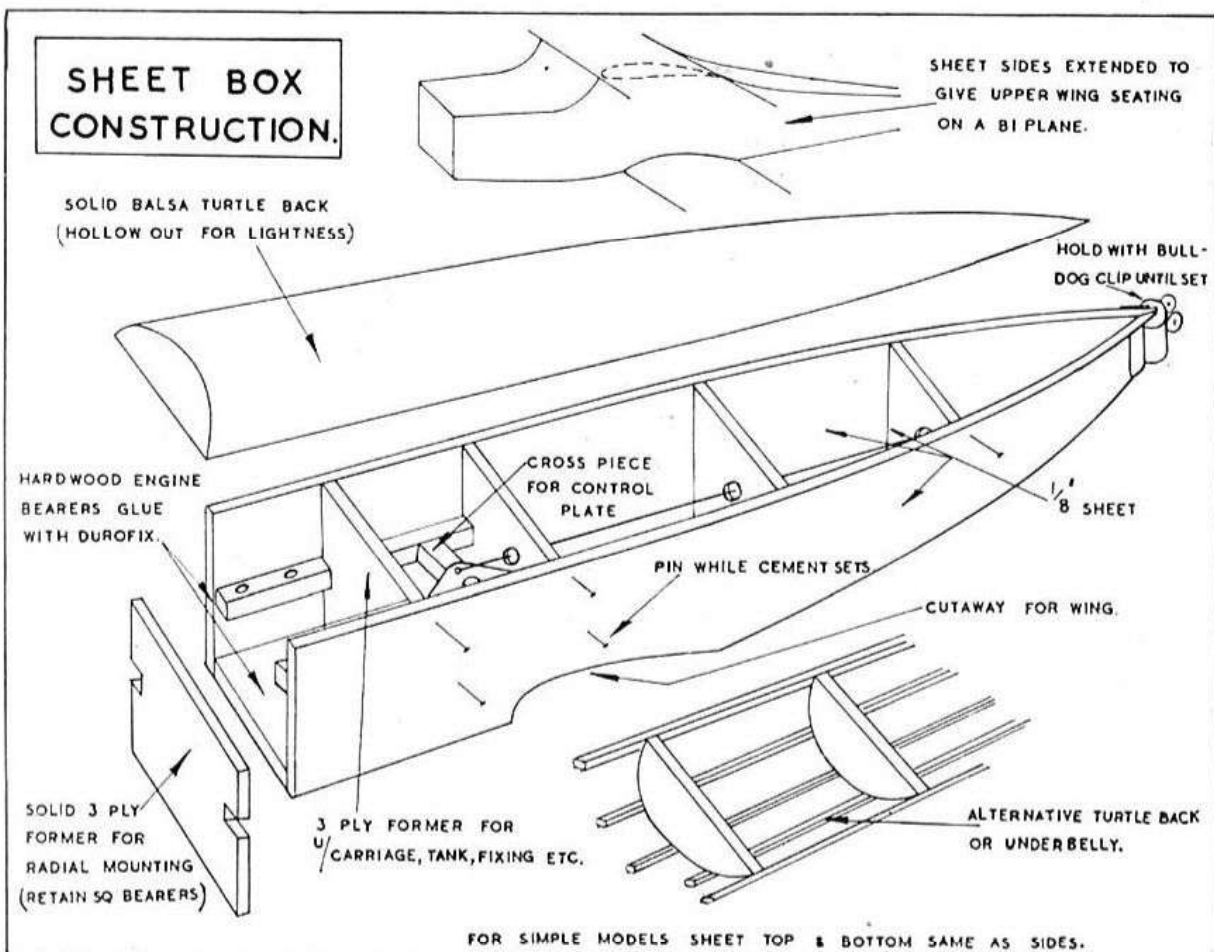

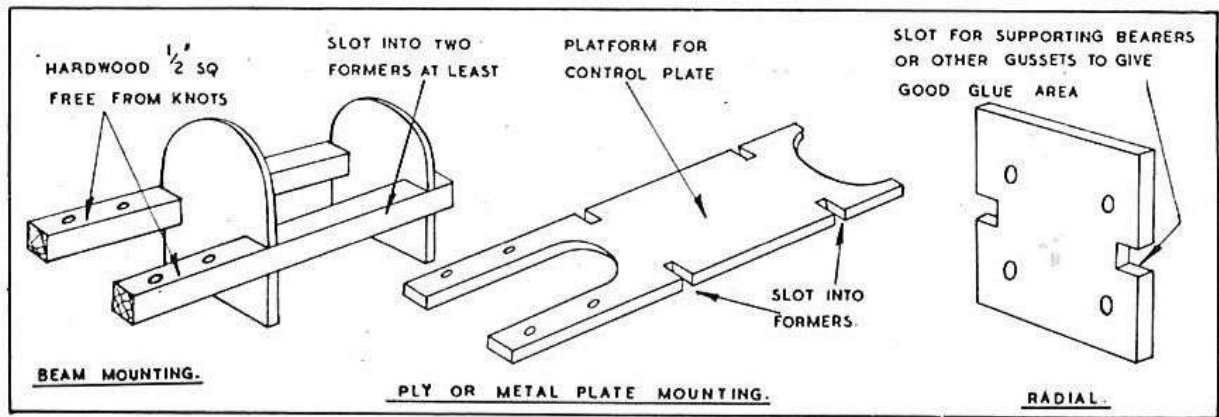

taste and drilled to take the engine beams at the front. Final fuselage shell is either composed of thin aluminium sheet bolted in place, or hollowed wood top and bottom similarly fixed. It has the advantage that it is virtually indestructible, cannot warp, and will never vary in a series of identical castings. This is only suitable for high speed work, and will hardly find a place in British methods until some kindly manufacturer provides those hotted-up engines capable of over one hundred m.p.h. in a big way. Another bright American has been flying with a spun aluminium fuselage suitably strengthened within as in monocoque construction. This may have some future for kit manufacturers, but is not possible for the average modeller, and on the score of strength for cost has little to recommend it. For practical flying it is very prone to dents and has little more than freak interest.

For those determined not to go in for this fancy carving there is the usual aeromodelling compromise, a slab-sider with sheet sides and small blocks top and bottom to achieve an oval cross section with somewhat flattened sides. A more nearly elliptical effect can be achieved by using  $\frac{1}{4}$ -in. sheet sides and shaping these to a curved contour. Such a job can be quite strong and is simple enough for a beginner to tackle. There seems little point in a free-flight type of box fuselage with tissue covered sides, as it is unlikely to last out even the test flights. Try it and see.

The heavy mortality of airscrews experienced by every newcomer to this branch of aeromodelling has inclined more serious thought towards pusher types than has been in evidence for a long time. Canard designs or pushers seem the only way to keep the engine away from the accident and are worthy of study. In pusher types some form of twin fuselage is necessary, but need offer no new problems. As a general principle each boom requires to be just over half as strong as an equivalent single fuselage. A three-ply backbone, running vertically, with solid balsa fairings is perhaps the simplest solution. Or the fairing in an elementary type may be omitted if say  $\frac{1}{8}$ th in. ply is used. A round hollow boom of 1 mm. ply will also provide a strong if rather more troublesome job, involving fixing complications at each end, though the lead to the elevator horn can be fed down such a structure. In a machine intended for speed and powered by a 5 c.c. engine or larger there is much to be said for dural tubing, which can often be picked up for a song at government disposal yards or from the more canny model supplier.



Engine mounts come into two basic classes, beam and radial mounting. Hardwood bearers are the standard answer to the first class, or the smart little pressed alloy mounts now on the market. These can, of course, be easily bent up in the home workshop if preferred. A combination of hardwood bearer and metal engine mounting plate is a useful method, as this enables a variety of engines (assuming the builder has more than one, which seems the growing practice now they can be bought so easily and cheaply) to be tried without any major building changes.

It is important to see that the bearers go well back into the fuselage and are securely anchored to ply formers, or with crutch fuselages are adequately cross braced. Radial mounting is usually made direct to the front bulkhead, but care should be taken to see that convenient access is left for refuelling and choking the intake. As larger fuel tanks will be required in many cases, their location should be considered in relation to fixing. A special radial mounting plate is well worth making up if any difficulty is experienced in this direction.

Except in the very simplest of designs, engines should certainly not be left sticking up or down like sore thumbs. Some builders feel that in inverting an engine they have completed their contribution to streamlining, quite ignoring the fact that the pot still sticks out below, though, perhaps, less than it would have done if left in an upright position. Fitting a cowl for show purposes and taking it off for flight is just not good enough. Speeds are such that streamlining definitely does count, and cowlings must be made for use. The helmet or coal scuttle cowl is simple and does its job reasonably well. It can be made of solid balsa hollowed out, or better, beaten up on a suitably shaped mould from thin aluminium sheet. If it is hinged it should be so arranged as not to catch the hand when starting. The prop will damage the fingers without any supplementary aids. If completely detachable, some positive

arly American line-up with every engine mounted upright and exposed to view. Fortunately this trend is now disappearing with increased speeds and interest in cowling. Only one model it will be noted sports a spinner, others are naked and unashamed.

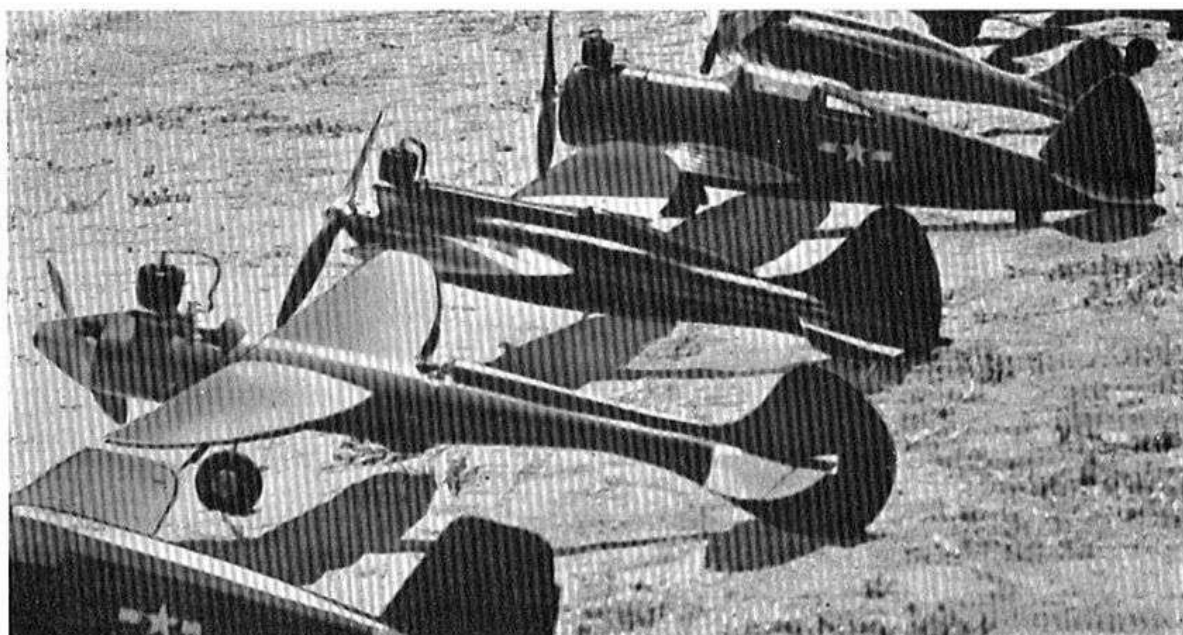

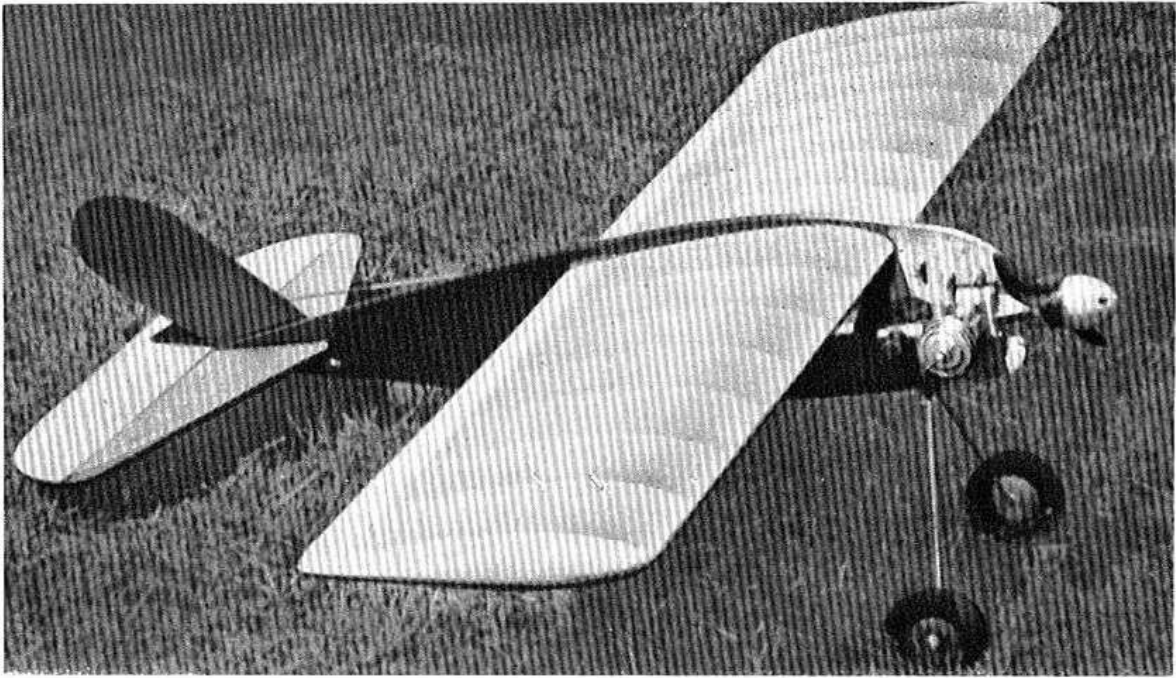

Pete Cock's Kan-Doo—1948 Gold Trophy stunt winner—is built round the simplest possible "flatfish" or outline fuselage of three-ply. Such a layout, with sidewinder mounted engine lends itself particularly to stunter construction, where initially there will be a more than usual amount of repair work to do.

fixing method is worth thinking up. Provision should be left for suitable exhaust exits and air for intake, or the engine may be starved and fail to give of its best. A built-in engine fairing for inverted engines must also have some means of draining fuel collected in its base. In the anxiety properly to fair in convenient access to needle valve, fuel tank, and intake must not be overlooked. Extensions to some or all of these may be necessary.

When soldering extensions to the needle valve it is worth remembering that paste fluxes or flux cored solders do not make for an easy joint with steel, where killed spirits will give a simpler, quicker and stronger joint. Surfaces must be washed after work is completed with warm soapy water or hot water with washing soda in it, or the joint will show signs of rust or oxidation within a day or two. An extension pipe to the fuel tank is not always necessary as a longer feed tube from the filler bottle will often solve the difficulty. If the air intake cannot be conveniently choked with a finger it may be simpler to fit a small rubber clapper mounted on a spring loaded lever to close up as required. The fit should be absolutely airtight as some engines are very baulky when inefficiently choked for starting.

The success of Pete Cock in the 1948 Gold Trophy, first British National Aerobatic Contest, flying his E.D. engined Kan-Doo model has stimulated interest in another fuselage form that has its American following—the "flatfish" or outline fuselage. Here a normal fuselage side elevation is used without any thickness other than the thickness of the sheet employed. Material is usually three-ply of 1/8th in. thickness, or even 3/32nd in., with engine mounted as a sidewinder. The result is strong, light, easily made and thoroughly practical. A variation is to lay out the side elevation as for a normal slabsider, making one side only, then sheet each side with 1/16th in. balsa. This is lighter still, though

a little more trouble. After seeing what Pete Cock can do with Kan-Doo it seems superfluous to criticise this form of fuselage, but, in less skilful hands it has one decided disadvantage owing to its lack of frontal area. It tends to horse, that is wiggle about its forward axis, thus losing flying speed and even getting out of control. Shulman and other American designers have overcome this advantageously by building up a shaped fuselage in front, which tapers into the "flatfish" just aft of the wing trailing edge. This makes a convenient housing for the control plate, a firm rest for the wing, or wings, and permits engine installation to be upright, inverted, or as the builder pleases. At the same time frontal area is increased and the horsing overcome. American builders have quite taken to the skeleton outline fuselage even for so-called scale models, which have a faithful adherence to side elevation—and just nothing at all to show in front.

The popularity of the biplane for stunt models is such that some comment on cabane struts is indicated. These may be, preferably, of wire, or hardwood, or a combination of the two, and must be firmly anchored in place. The old-time N-bracing of the cabane struts takes a lot of beating. However, in many cases the builder will be satisfied with the simplest possible U-shaped braces for the upper plane. The lower wing is usually attached direct to the lower surface of the fuselage in a slot cut out for it, and may be finally held firmly by a solid fairing that carries on the lines of the belly.

As a final reflection on fuselages, the designer is urged, at any rate in his early control line models, to build for strength before everything. Later he can take pride in elegance of line and finish. If the fuselage is strong, the undercarriage stoutly secured, and the trim reasonable, there is little that can disturb his early ventures other than a succession of broken props.

An elegant jet fuselage—where the motor is entirely concealed. Apart from fire hazards this is a quite practical method and must be preferred to the common practice of pylon mounting which can only be described as built-in instability.

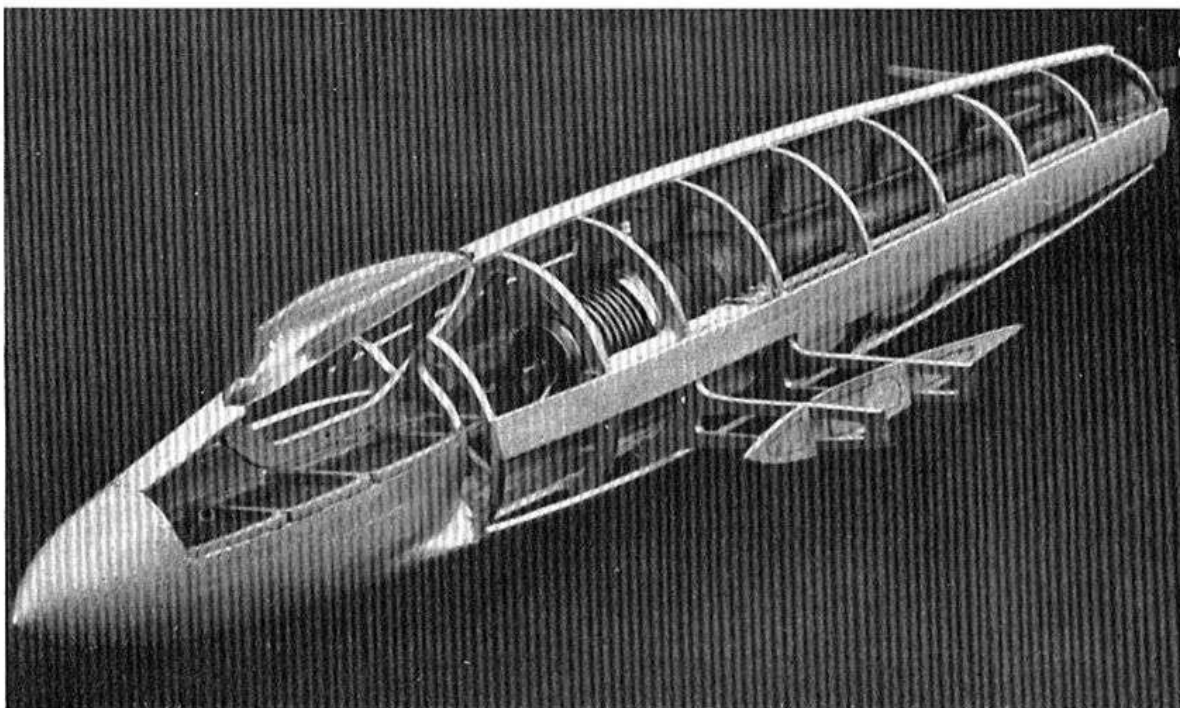

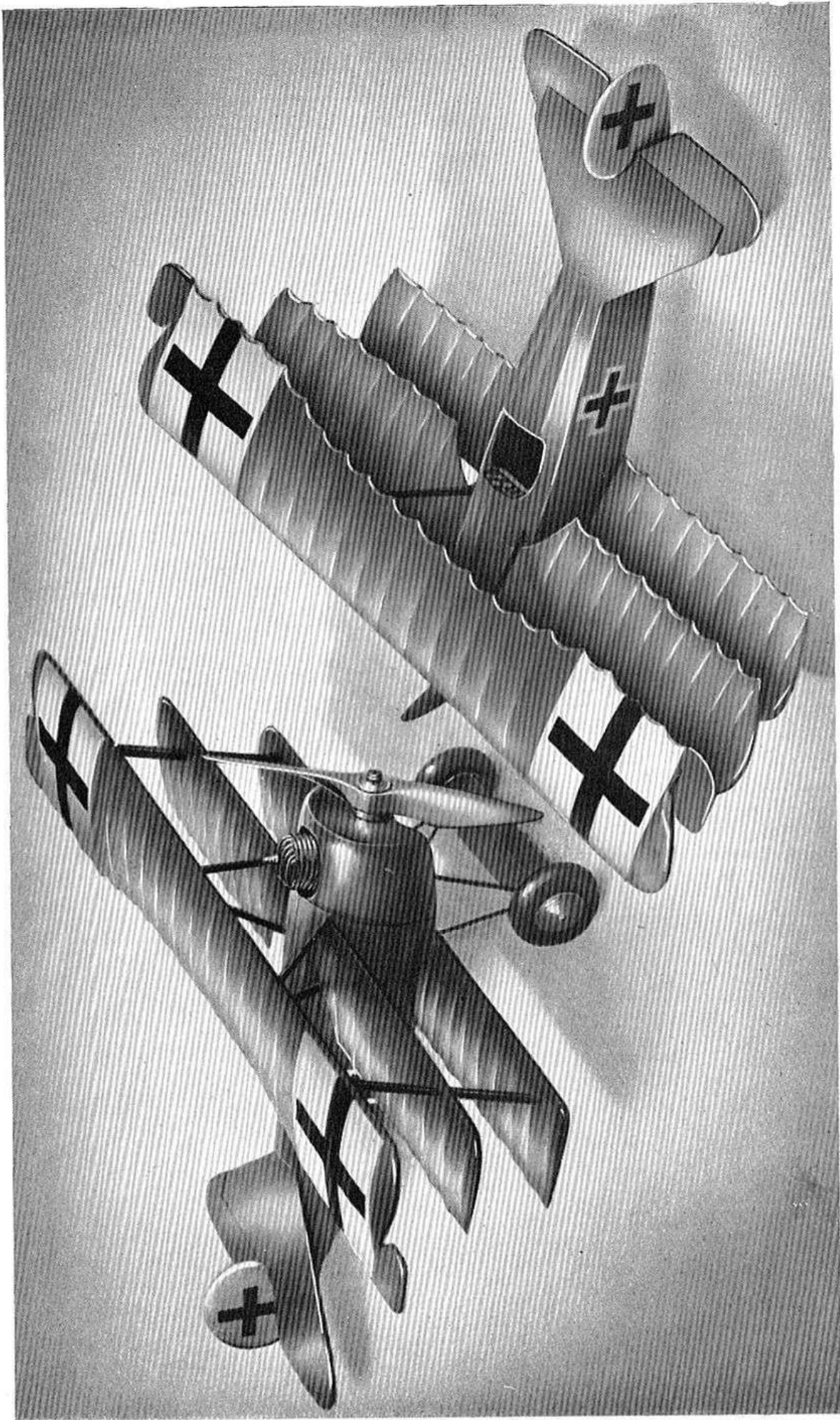

Famous old timer scale triplanes lend themselves particularly to control line flying. The model of the Fokker Triplane shown here, finished in its authentic brilliant colouring, is a certain centre of attention wherever it is flown.

## CHAPTER FIVE

### WINGS

IT should not have taken many flights to convince the newcomer that converted free flight machines lack sufficient strength to stand up for long to the hard work involved. Equally it should have been grasped that, except on those rare dead calm days that few of us have the patience to wait for, such machines tend to fly themselves and so get out of control. This naturally suggests that built-in stability is not desirable in a control line model, and may even invite the heresy that wings are an unnecessary luxury. It is not the present intention to go deeply into such a thought other than to state categorically that a model will not fly without any wings at all. High speed enthusiasts have gradually pruned down wings until they are little more than stubs, but have not managed to eliminate them entirely and any study of aerodynamics will convince the reader that, in the light of present knowledge, he will have to endure them for a little longer. We would go further and add that the vast majority of enthusiasts have found that the correct design and construction of flying surfaces contribute more than a little to the success of any model. Except for slow flying models, such as flying scale versions of old timers or light civil aircrafts, an entirely new approach to the subject must be made if a more than normal amount of time is not to be spent patching up breakages.

Let us be quite certain what we want in a wing before proceeding to any specific discussion. If we are building a normal "trainer" or "sports" machine, high speed is not essential, and on the contrary rather to be avoided. We have something not so very different from a free flight model responding to our controls instead of relying on efficient trimming and built-in stability. As we shall be making the model climb by an inclination of the flipper there is no call for a high lift section. The model cannot climb higher than the length of line—if it tries to do so then the stage is set for one of those spectacular wing-overs that usually beset the novice flying a goat; a manœuvre he would be happy to see when achieved by design, but a most unwelcome occurrence when he can hardly do circuits and bumps. Our choice then is limited to a sound airfoil section that in itself is moderate in performance when set at a low angle of incidence. To keep the matter simple a section with flat or only slightly cambered undersurfaces will make for ease of construction. Under this heading will come such old favourites as Clark Y, US 27, N.A.C.A. 4412, or 6412, or N.60. Slow flying sections with undercamber are not recommended, and will in fact be quite impractical as soon as the simpler manœuvres are mastered and the tyro

tries a stunt or two. As proficiency is acquired and higher speeds attempted a sleeker and sleeker airfoil section will be desired. This can be achieved without any spectacular calculations simply by taking a percentage of whatever section has already proved satisfactory. For example, 60% of Clark Y makes a start in the right direction. In general any of the so-called fast sections that have been recognised as suitable for model use may be utilised. Some enthusiasts have had good results with a combination of Davis upper surfaces and symmetrical N.A.C.A. undersurfaces. There is no reason whatever for the builder to accept any standard section and get into the rut that has beset certain aspects of the hobby. Let him rather get out pencil and paper and draw up his own idea of a suitable section within the limits suggested above. It may be good, bad, or indifferent, but it will certainly be an effort to produce an original idea.

Before leaving the subject of airfoils it should be pointed out that for advanced stunting a symmetrical section must be used. Otherwise when the machine is flying inverted there will be a tendency to climb "down" at any instant when the flier is not counteracting this urge by up-elevator. The actual instant of commencing so to fly is the critical one, as the controls are reversed and "down" becomes "up," as will be explained in the flying chapter later on, and if the stunt is attempted at low altitude a mistake may only too easily end in a painful write-off. A symmetrical section is not however necessary for ordinary loops where the flight path is circular.

Wing loading has always been a controversial point with power models, and we should hesitate to make any arbitrary statement of limits. We would point out that if a proper degree of manoeuvrability

Simple beginner's model with solid balsa wings. These take a lot of hard knocks and are unequalled for training machines. The lead out through tubes is not, however, to be recommended, as it tends to binding of the controls. In practice the lightweight wheels would also soon suffer damage.

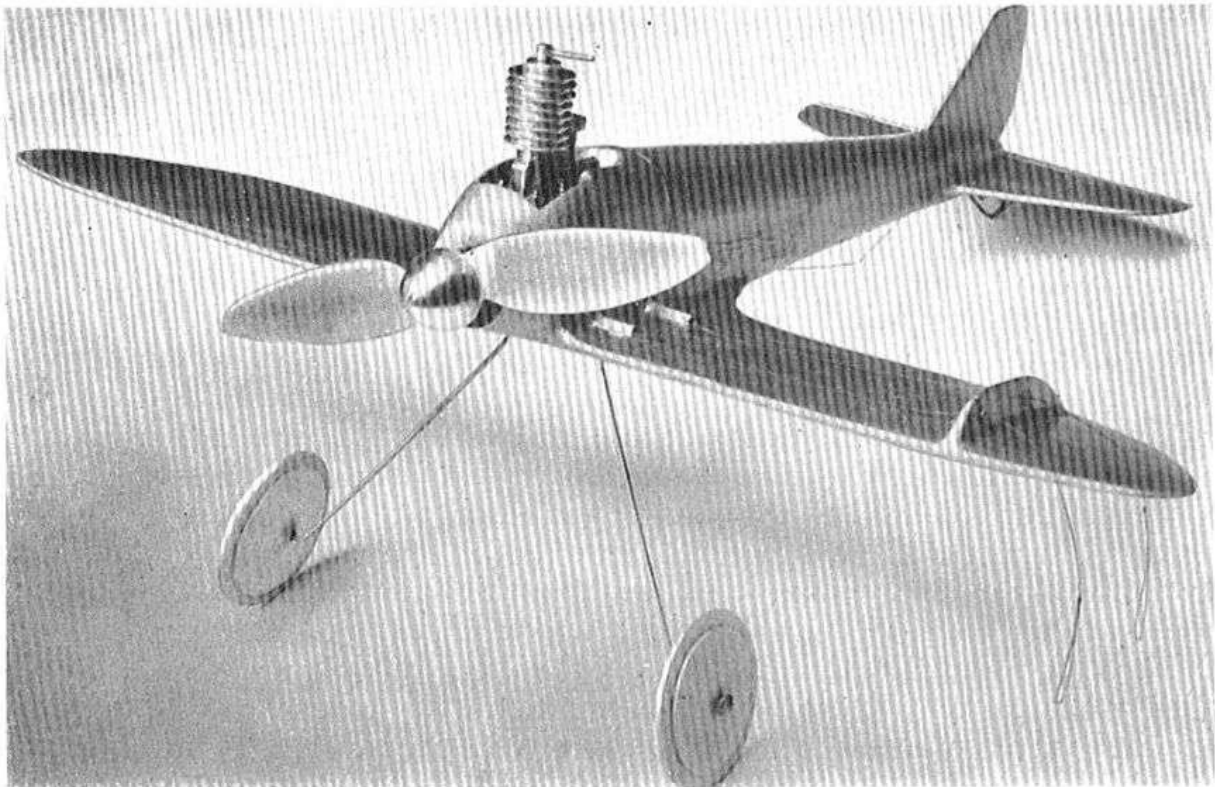

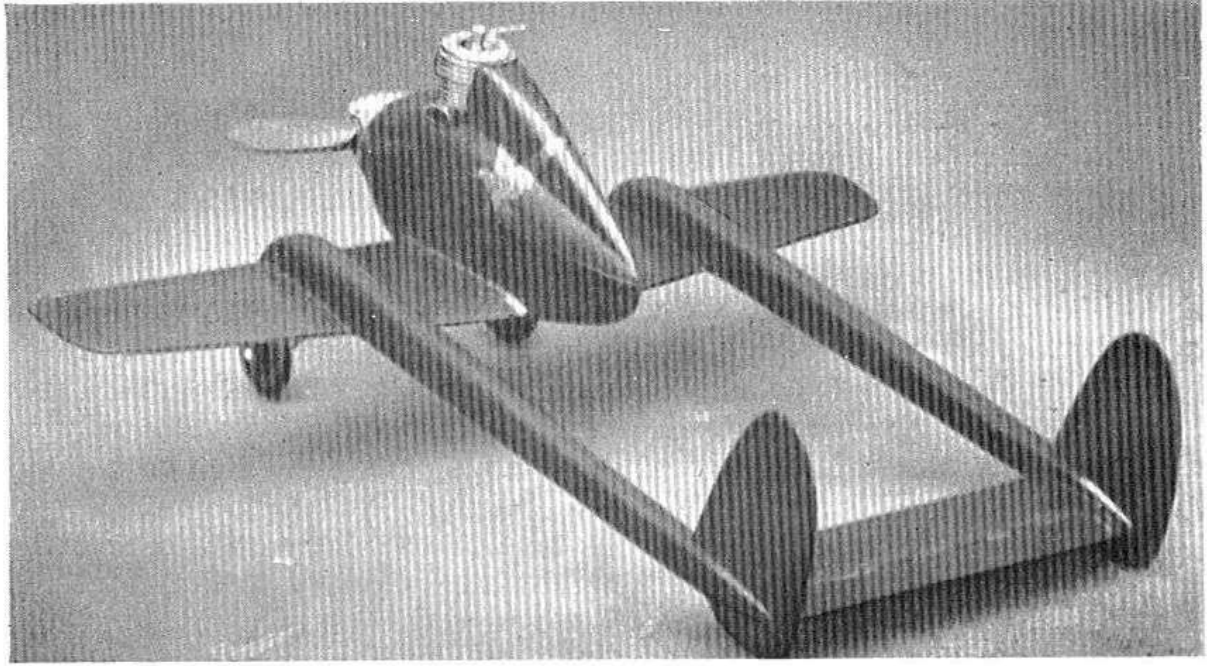

Substantial twin boom model with solid wings, which provide a firm attachment point for the booms. Streamlining of engine is not necessary in a model of this nature which at best would be capable of only 70-80 m.p.h.

is required, then the lift at  $L/D$  maximum at a particular Reynolds Number *must* exceed the all-up weight of the model. In other words, you must have a bit of lift in hand if you are not to rely on the rather doubtful assistance given by our old friend centrifugal force. If the builder is content for his model to hurtle round in a flight path barely off the ground at an excessive speed, which will require considerable skill to control, and even more to land in one piece, then such limitations do not apply. Indeed, some of the earlier and more fantastic American speeds claimed might seem to have been obtained by such means. Happily, wiser counsels have prevailed and American flying is now based on sounder aerodynamic principles.

A number of writers on control line flying in this country have fallen into the—to us—curious habit of giving wing loadings per 100 sq. ins. rather than in the more usual per square foot. Free flight models are normally so described, and for the purposes of comparison it seems to us better to retain this system. For speed models a wing loading of from 25 ounces to 30 ounces per square foot seems productive of the best results. An analysis of some of the more successful models finds most of them within these limits. These figures will be noted as approximately twice the wing loading of the heavier type of free flight power models. Higher wing loading naturally means faster flight, and even the so-called slow flying trainer machines, with wing loadings around 18 ounces per sq. ft., will be found flying nearly twice as fast as the average free flight model. One happy result of this increase in flying speed is that many scale designs usually considered unsuitable for models without extensive modification can be built more or less unchanged. The control line fraternity have been quick to grasp this salient point, and many delightful fighter and racing prototypes have been faithfully reproduced. Equally, of course, these increased wing loadings raise new problems of construction. There is no room for

slipshod work, and strength must be the keynote of every part—not least of all the wings.

Both for simplification of rigging and to reduce drag a low angle of incidence is desirable. Very many models are built with the main-planes set at  $0^\circ$  to the datum line. It should seldom, if ever, be desirable to have a positive incidence exceeding  $1\frac{1}{2}^\circ$ . This does not mean that wings have no lift at this angle, obviously the average airfoil under consideration possesses lift within a setting range of from minus  $5^\circ$  to plus  $10^\circ$ , or even more. Structural advantages of a low wing model with wing set at zero will be obvious, and no advantages accrue from setting it at a positive angle as it would merely tend to climb unduly and have to be restrained with down elevator adding yet more to the sum total of drag.

Just as the elevator controls take care of longitudinal stability, so does the pull of the control wires take care of lateral stability. A control line model is therefore better placed than a full-sized aircraft in that it can *only* be unstable about its longitudinal axis and that subject to the control of the operator. It has the limitation that it can only perform manœuvres about that same axis, whereas the full-size aircraft can perform three dimensionally, but there is nothing we can do to overcome that. It becomes clear therefore that dihedral is not necessary for a control line model. Many models continue to feature it in some modified degree, but, frankly, we can see no more reason for it on the score of necessity than for the plastic cabin that decorates many

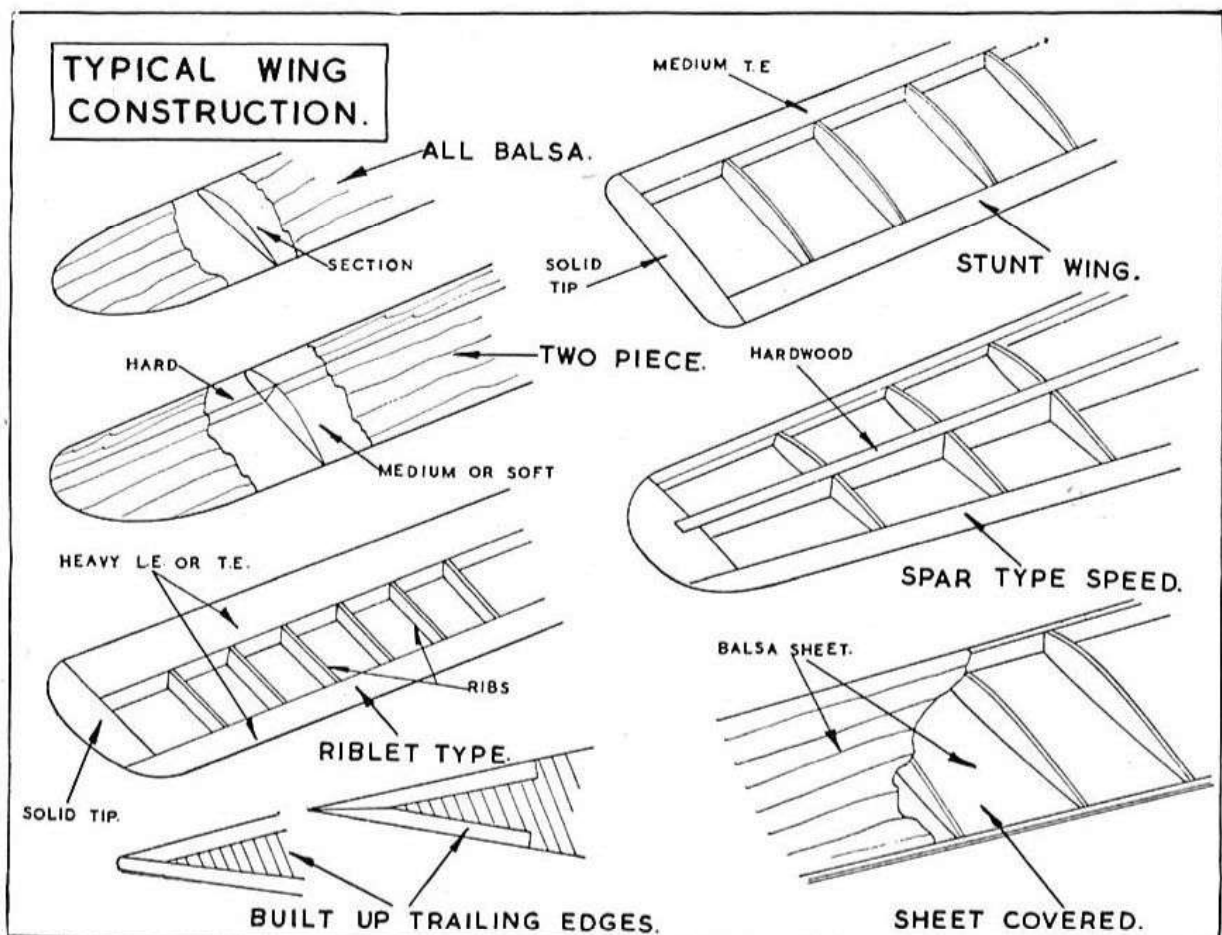



a semi-scale model. The only time it may serve a useful flying purpose is when the model is blown inwards by a gust of wind and becomes momentarily free flying. Such an occasion is always the subject of hasty back-stepping to bring the model under control again, and we have yet to see a model assume automatic stability and go on flying in default of some such action for more than a second or two. Dihedral does occasionally have a structural justification, as for example, to bring a wing tip to the right height to receive fairleads for the control wires without the addition of an unsightly extension piece. Those who build scale models will naturally retain the dihedral of the prototype for true scale appearance. Others may copy designs with elaborate inverted gull and other unusual shapes. For such models it is recommended that the wing is assembled on a single jig. Spans are normally so small that nothing complicated is necessary, and the extreme accuracy of rig desirable for trouble-free flight is thus ensured with little trouble.

Aspect ratio on the average model may seem low from free flight standards. Optimum is from four to six depending on the type of model, that is, trainer, stunt or speed design. There has been a tendency in the last year or two for the experts to develop a higher aspect ratio comparatively slow flying stunt model going up to a figure of seven or eight. No hard and fast rule is suggested for this class as so much more depends on the stunter than the actual model flown. An expert can make a goat do things the novice would shudder at, equally the beginner would find nothing magical about the flying of a winning model in his own inexpert hands. As an equally powerful American group of stunt experts is now concentrating on fast stunt models, the aspect ratio of the stunt plane must rather be thrown on the table as an open question. There is the salutary thought that an unsuccessful stunt taken fast is more damaging than the same taken slow.

For the trainer or general purpose sports type of machine a figure of six gives both pleasing proportions and no untoward structural problems. This will no doubt continue to be the most popular figure, securing the greater proportion of prizes in average events. Speed models, on the other hand, tend towards the practical minimum of four, giving a deep chord and added strength to the thin sections used, which would be unduly fragile if much extended.

One development that may be regarded as surprising is the new popularity of the biplane for control line flying, which enables a fairly low aspect ratio to be employed with, at the same time, an adequate wing area that reduces wing loading. Such a design is a popular layout for stunt machines giving surplus of power to get the model out of any ticklish situations an over-ambitious operator has created. Here the upper plane is usually of greater size than the lower wing, and is supported by a stout streamlined interplane strut only without bracing wires. Gap may be  $1\frac{1}{2}$  to 2 chords and stagger up to 50%. Decalage is occasionally  $0^\circ$ , but more often lower plane is set at  $0^\circ$  and upper plane at  $\frac{1}{2}^\circ$  to  $1\frac{1}{2}^\circ$  positive. Some of the symmetrical wing section stunt biplanes—notably the de Bolt—have negative incidence of up to  $2^\circ$  on the upper plane, lower being at  $0^\circ$ , which seems to be a thoughtful provision for inverted flying when the model will tend to have more

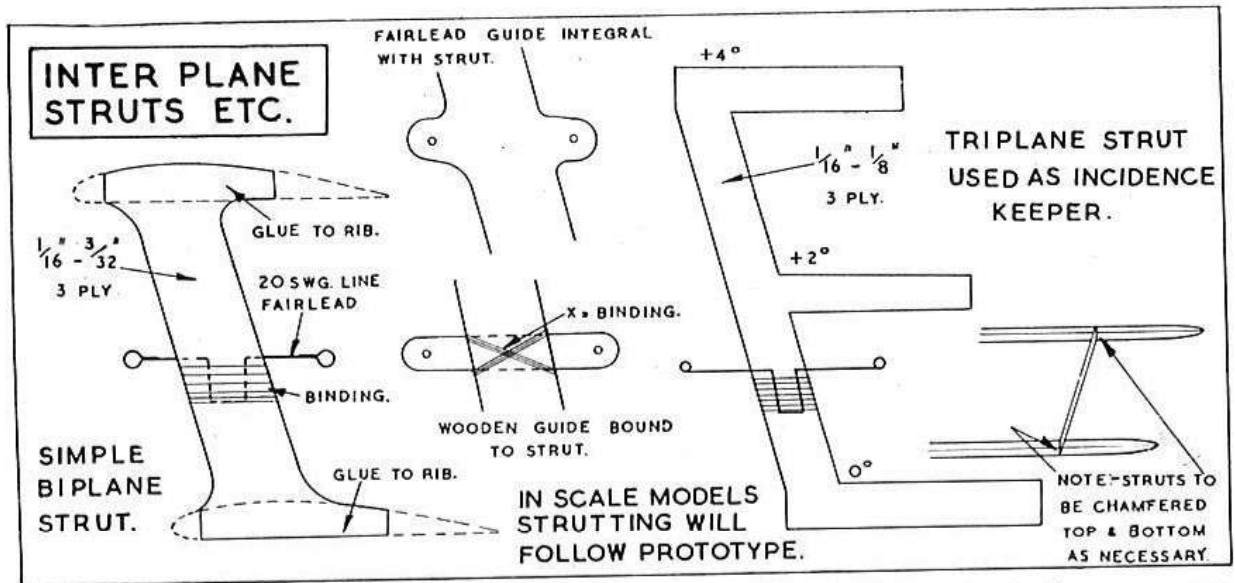

lift than in the normal position, thus helping to counterbalance some lack of dexterity at the inverted controls. From France comes the Dervish—a winning stunter in 1948—which employs negative stagger (Shades of the old Beechcraft!) and again we can see no particular justification for it but the fact that it is easier the other way up!

Many old time favourites such as Nieuports, Bristols, Camels, and even Triplanes such as the Fokker, have proved popular in kit form in the States. There is certainly something about the biplane once any initial prejudice against it on account of difficulty has been overcome. This is non-existent, in fact, and the only biplane second thought that is worth anything is the prospect of making two more wings!

Unlike free flight the control line trend is towards low wing design. Perhaps the early enthusiasm for speed, now giving place to stunt and precision flying in America, may be the reason for this, plus the ease with which the highly publicised war planes during its formative years could be reproduced in model form. For cleanness of outline we would recommend the low midwing, with control wires concealed in the thickness of the wing and leaving fairleads at the wing tip. This is a layout that recent high speed record breakers have followed.

A finely detailed scale model of the famous Tiger Moth that upholds the fine flying characteristics of its prototype on the lines.

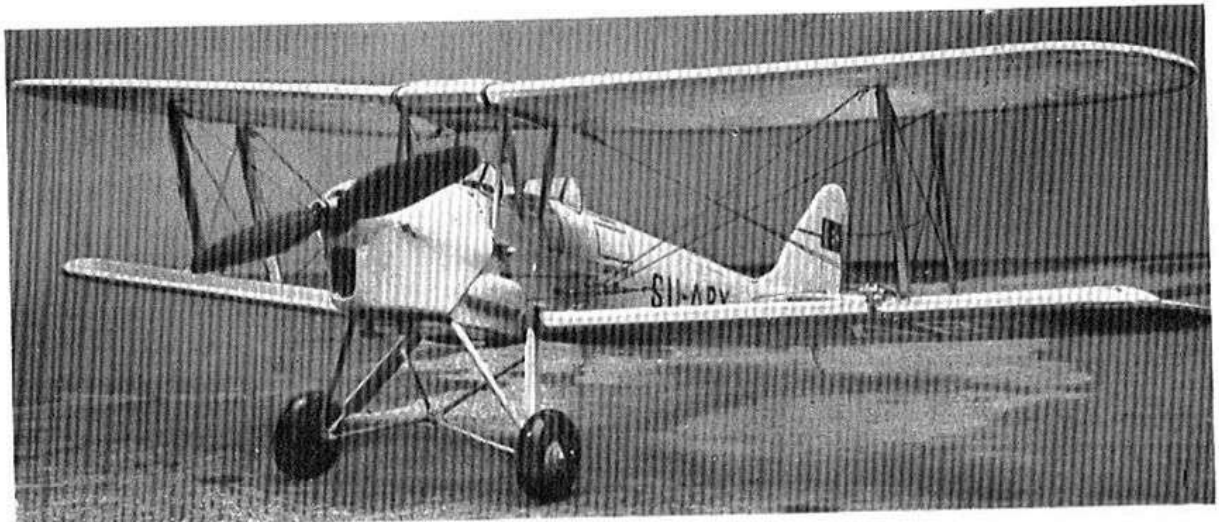

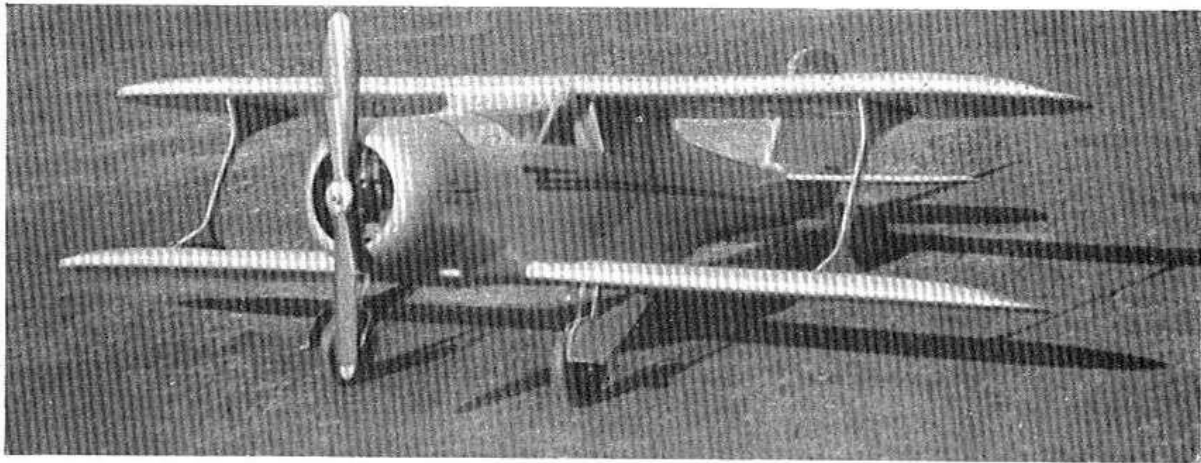

Scale model Beechcraft that captures the spirit of its well-known prototype—almost the only full size machine with negative stagger. Bulky fuselage, allowing engine to be completely concealed, makes it particularly suitable for the aeromodeller.

Where a high wing layout is used some form of control wire fairlead must usually be dropped to enable the wires to be positioned correctly for adequate control, as will be explained in the relevant chapter. It follows that, given free rein in design, the builder should locate his wing at the spot most convenient on the varied counts of drag, control wires, position of accessories in the case of petrol engined models, and convenience of construction. In short, the usual aeronautical answer of compromise. The high pylon wing, or even the parasol in any but scale models, seems definitely out.

What shape should the wings be? Here again with stability problems all taken care of, the designer may back his fancy as he pleases. Experts have pointed out already that the most efficient wing form is rectangular—but very ugly! Nature, which abhors straight lines, gets over the difficulty in the case of the more conservative birds by rounding off the corners, and this is the best way with a model where simplicity and efficiency is required. Parallel chord wings with the outer panels blended into any pleasing curve makes another of those satisfactory compromises. There is loss of lift, but we have already agreed that lift is not required to that vital extent. A large proportion of successful designs have sharply tapering wings, with an almost straight leading edge and wedge trailing edge. On the score of looks and structural efficiency a tapering elliptical wing based on the Spitfire shape has our vote.

The span of the model will naturally depend to an extent on the power unit proposed and the length of line likely to be most convenient. In this country it is virtually impossible to obtain a good engine in the 10 c.c. class if we exclude one or two specialist manufacturers who, by the very quality of their products, reduce output to a negligible total. Diesel engines of a maximum of 5 c.c. or petrol engines up to 6 c.c. seem the practical maximum for the majority, while ninety per cent of the builders will be making their debut with a diesel engine of less than 3 c.c. in mind. For this reason we would suggest 40 in. as the maximum span that need be contemplated, with a figure around 20 in. as a useful starting point in the case of smaller engines. Speed merchants will be thinking along the lines of 5 c.c. diesel and 20 in. span, which is quite practical for the expert but deadly for the beginner.

There remain now the practical questions of how to build the wing strong enough and efficient enough to do its job. A primary concern is to maintain the whole wing at the designed airfoil section. Any tissue covered wing will tend to sag between ribs and destroy some of its efficiency and add to drag, which may not matter much at low speeds, but certainly does at high.

An increase in the number of ribs and the addition of riblets with suitable capping strips will help to cure this tissue sag. Sheeting in from leading edge to main spar is another solution to the sag problem. But the question of spar strength remains. Dives and sundry other manoeuvres impose special strains apart from unrehearsed contact with Mother Earth. Spars should therefore be the full depth of the section, and not notched to any extent, which is a weakening move. This means that ribs must themselves be cut, a method that has never been very popular. To retain the one piece rib, thicker spars of less than the full depth may be used, or box spars on which the ribs are threaded.

Weight is not quite so important as in other forms of model flight and need not be so large a factor in considering increased strength. A handy solution is to cover the whole wing with 1/32nd inch sheet. This makes a delightfully smooth covering, and will take a high degree of finish if suitably treated with filler before painting. For added strength such wings may be tissue covered and then painted, thereby avoiding weight increase by soaking of filler and paint into the wood, but a really high polish is not so easily obtained. When rubbing down any thin sheeting there is a danger of rubbing too hard over the rib joints, thus weakening the structure and defeating the object of covering. Soft 1/16th in. sheet obviates some of this risk and gives a strong wing that will take a lot of punishment.

Borrowing from the memories of our chuck glider days may be found what many consider the ideal solution, at any rate for wings of moderate span—solid balsa. Using soft sheet, say half an inch thick, the wing may be carved with the aid of templates to a perfect form. Its all up weight will be little more than a sheet covered wing and its lavish use of cement fillets and so on. As the chord will usually be more than 3 in., which is the average maximum width of sheet, it will be necessary to join two or more sheets edge on to make up the width of the wing. A refinement, therefore, is to use hard balsa for the leading edge section and soft balsa for the rearmost part. In the case of a wing wider than 6 in. a final piece of hard balsa for the trailing edge gives the best possible combination of woods. Where dihedral is desired, ply dihedral keeps the full depth of the section should be firmly cemented in saw cuts made with a fretsaw. The whole wing is well sanded, treated with filler, and a smooth drag-free piece of work should result when brush-painted or sprayed. Another consideration which we pessimistically add is that should even this wing be broken the offending section can be swiftly cut out, a fresh piece of balsa grafted in, and trimmed to true profile, provided the original templates have been retained.

Another modification, is to glue lightly together two sheets each of half the maximum finished thickness, carve to shape, split and hollow out to taste in the same way as a hollow log fuselage.

Reverting again to compromise, solid leading edges about one-third of the chord and similarly stout trailing edges may be used with riblets between. A main spar in this instance is not essential. The Babcocks in their record breaker Jughaid employ such a method, adding, however, a stout one-piece hardwood main spar, through which a locating screw secures the wing to the fuselage, and a 1/16 in. covering goes all over. The hardwood main spar is also in this instance used for attachment of the control plate.

The pull of the control wires is such that rigid wing fixing is necessary. A number of designs have wings fixed permanently in place, but for ease of transport detachable mainplanes are often desirable. Let us consider fixing methods. Where crutch type fuselage construction is employed, and the crutch forms a wing platform, small holding plates attached to its under surfaces will suffice, provided the upper part of the fuselage beds down firmly.

A screw through the upper part of the fuselage mating with a hole or plate attached to the main spar, and screwed into a nut in the lower part of the fuselage offers an efficient and entirely satisfactory answer. Bicycle spokes are useful in this connection, the screwed nipple being the lower retaining nut. Locating pegs are another answer, though such fixtures should always be through hardwood blocks with plenty of "land."

End of the flight. Rubber band fixed wings are always liable to move in flight causing binding of controls—a state of affairs which terminated this model's antics in the inverted position. Little, beyond portability, is achieved by such a fixing for wing has not knocked off, but driven back into fuselage, probably causing more damage than would have been inflicted in a fixed wing model.

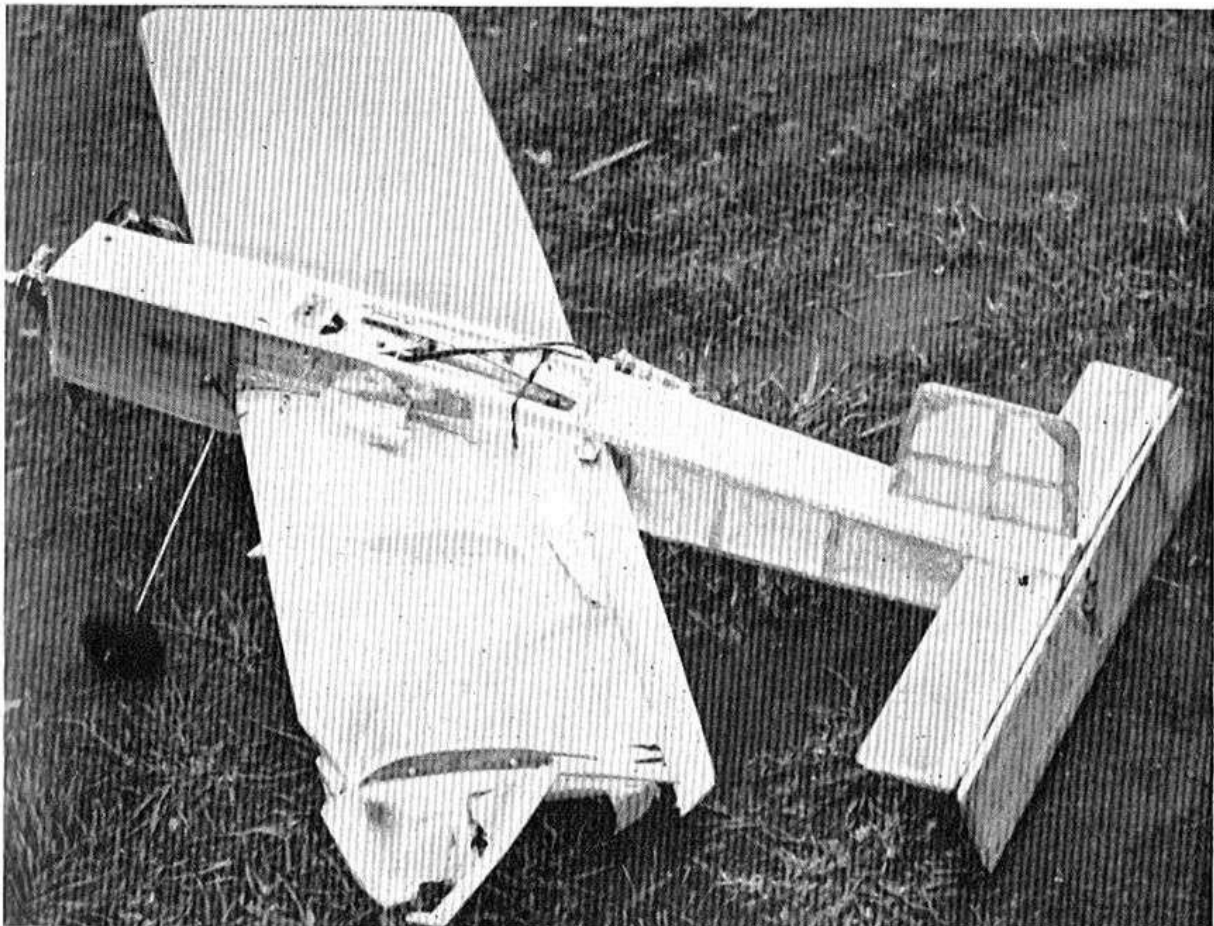

CHAPTER SIX

CONTROL SYSTEMS, CONTROL PLATES,  
ELEVATOR HORNS AND HINGES

THE introductory chapter dealt briefly with the principles of control line flying, but we propose here to recapitulate the main features. First, the model is flown in circles round him by an operator who retains control of the model by one or more lines, extending from a handle which he grasps to the model, where they, by one or other of several systems, actuate a movable elevator on the tail. Thus an upward impulse to the elevator will make the model climb, while a downward impulse will cause it to dive. Within these limitations a skilled operator can perform all the aerial evolutions that are possible in a two dimensional plane. Thus, imagine the model as a fly walking on the inside of an inverted sugarbowl—every antic it could perform without losing contact with the bowl can be done with a control line model. To make it simpler still, consider that fly as limited to the inside surface of that bowl, but now flying free *on that plane only*; all it does, flying upside down, looping, figure eights, and so on can be carried out deliberately with a control line model. In addition to such “crazy flying,” called stunt flying or aerobatics, which forms one branch of the sport, there is another equally important that devotes its activities to sheer speed. Here a different technique is employed, for the model is designed, and the flyer concentrated, on keeping the model flying in level circuits about him—if its flight path is erratic then it is travelling further and as the speed is estimated on the length of a level circuit a figure lower than actual is recorded. The amount of control and the nature of the control surfaces will therefore differ on these essentially different types of models. A further intermediate type of control will be found desirable on training types and general purpose or “sports” models.

A number of different control systems have been devised, but the best, or at any rate the most widely used, is the U-control method invented and patented by Jim Walker in the United States. This employs a triangular shaped control plate, firmly anchored about a pivot point, free to move within limits in a direction at right angles to the line of flight. This in turn is connected to a hinged elevator by a *rigid* rod, usually of piano wire, and via a small horn gives up and down movement to this elevator. Its beauty lies in extreme simplicity, positive action, and the ease with which all components can be fabricated at home, or purchased for a few pence. The length of the rod connecting control plate with elevator horn will influence the amount of up and down movement given to the elevator. The distance of the attachment

point of the rod from the pivot point of the control plate, and the size of the horn will influence the fierceness of this movement. Thus speed models will have very little movement, as no violent changes of direction are desired, whilst stunt models will have a considerable amount. This is more simply explained in the accompanying diagrams.

The distance apart of the two attachment holes for the control wires on the control plate will also influence fierceness of movement. The wider they are apart the quicker will be the elevator response. For this reason in beginners' or training models it is advisable to make the most of the various combinations that produce the least possible movement for the greatest movement of the control handle, to which wires are attached. In the early stages, handling will tend to be clumsy, initiating movements which cannot be successfully countered before the model gets entirely out of control. Ways of combating this clumsiness are covered in the appropriate chapter on flying.

The Stanzel type of control has not yet found favour with British modellers. This is perhaps because it is not so simple for the builder to make himself, though, where the complete control unit is supplied, ready made in kits, as in America, it enjoys a following. Basically the system employs *flexible* leads from a double control horn on the elevator, which travel via two horizontally placed wheels, or bobbins, to a roller. From this roller two control lines extend to a handle held by the operator.

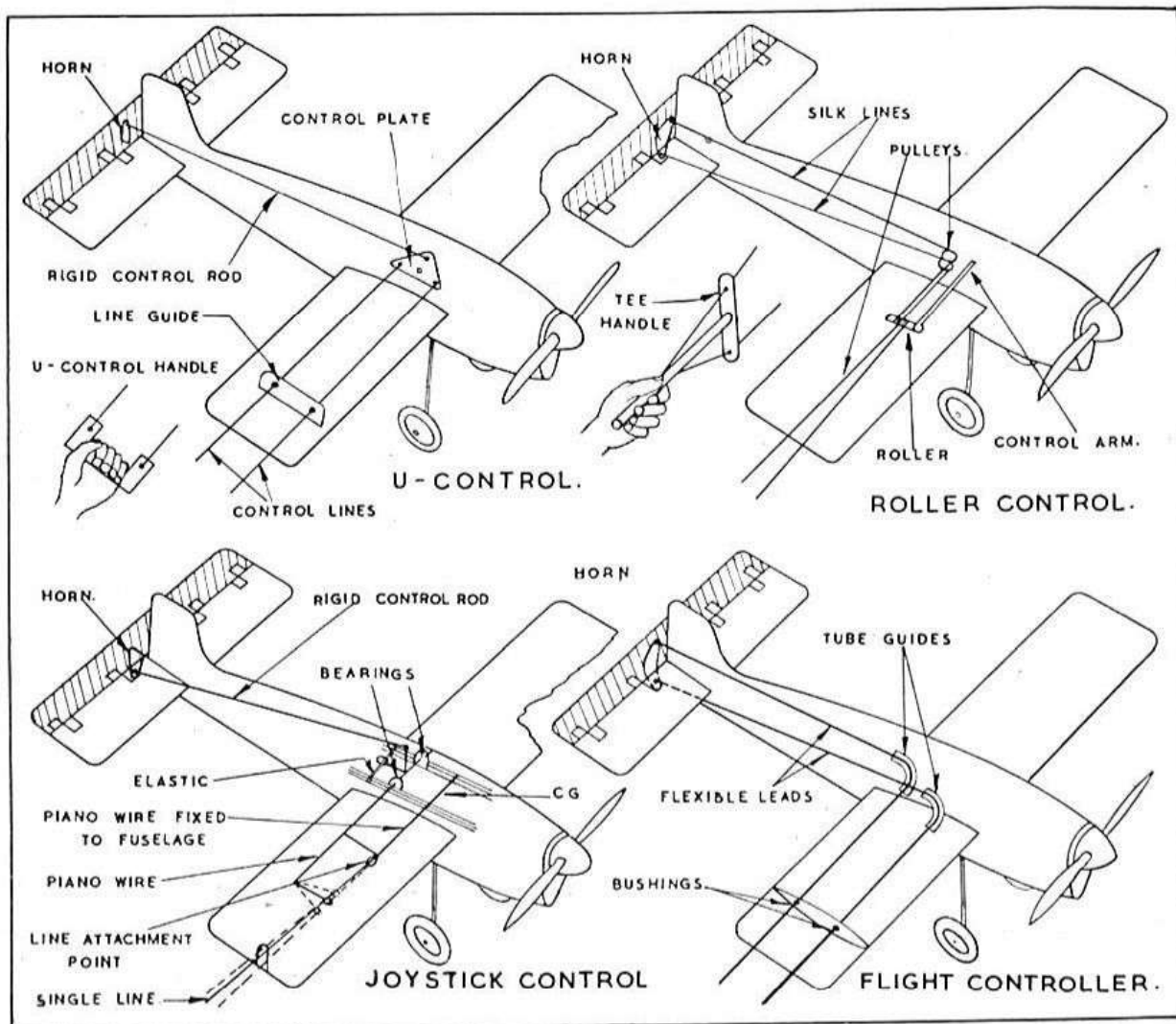

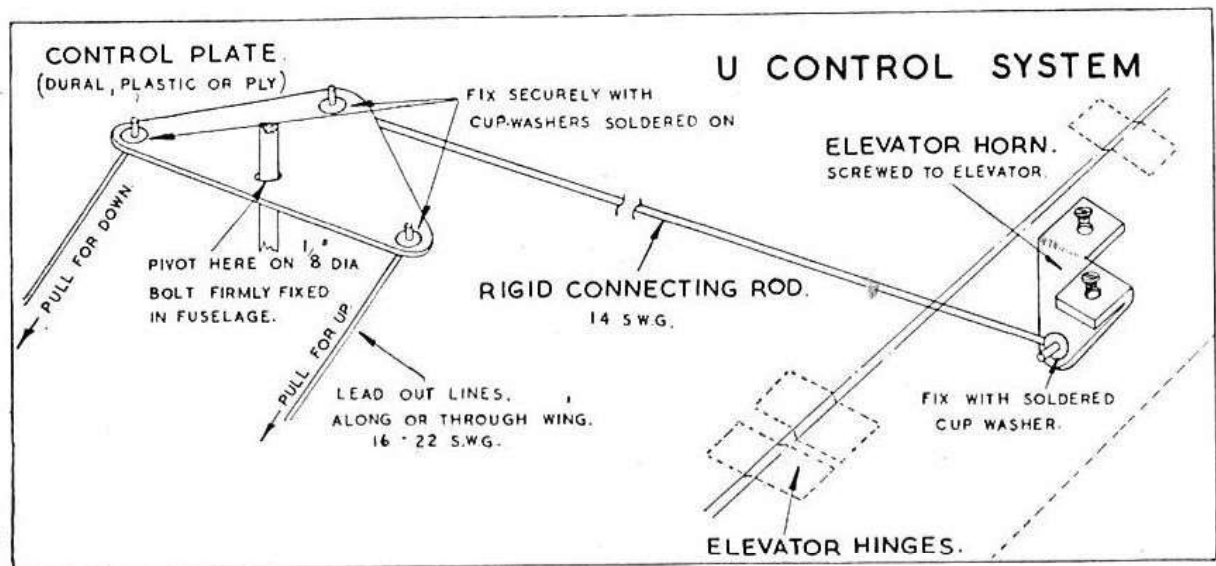

By twisting the roller up and down movement is given to the elevator. Improvements to this method now include a single control horn with rigid connection, and a spring loaded spring type roller, from which a single line gives control. The roller in each case is located outboard from the fuselage on a rigid pylon fixed slightly ahead of the C.G. An advantage claimed for both variations is that this outboard location of the roller must give some degree of automatic pendulum stability on a horizontal plane smoother in operation than the Jim Walker method. A further obvious advantage to the improved method is the reduction of drag when flying speed models on the single line. While the manufacturers do not normally intend builders to construct their own roller mechanisms, we include details so that a personal opinion on the relative value of the method can be gauged by the curious. The improved system is basically the same, but the rollers are spring loaded, returning automatically to neutral. Up and down movement is obtained by raising or lowering the control handle. Once more the diagrams serve to explain the method more lucidly than words.

A third system that may have some following here is the flight-controller method. Here the double elevator horn is again used, with *flexible* leads led out to the control lines via curved tubes securely anchored in the centre of the fuselage. A disadvantage of this method is that the control lines are connected directly, via the tubes only, to the elevator on the model, so that the faster the model flies the greater the strain, and consequently the greater the binding effect on the part passing through the tubes. Controls therefore become stiffer and less responsive at a time when, if anything, added sensitivity might be welcome. It is also impossible to vary the *degree* of response such as can be done with U-control by changing pivot holes, and even in the Stanzel system by changing size of rollers. For this reason the system has little support except from a number of commercial kit manufacturers who welcome its simplicity and cheapness, quite apart from saving royalty payments in the United States!

Finally, there is the single line system using a form of "joystick," which is actuated by raising an arm attached on the C.G. line parallel to the pivot rod to which the joystick is firmly soldered. A rigid connecting



rod leads from the top of the joystick to a single control horn. The pivot rod returns automatically to neutral when movement is eased by means of centralising elastic band tensioners. Apart from some soldering work, this appears a very simple scheme which deserves greater support than it has received, particularly for use in speed models and on other occasions when low drag is desired coupled with a limited degree of elevator movement only. This, indeed, is the only snag of the system, that movement is somewhat limited, and therefore suitable only for sports and speed types.

It seems likely that most control line flying in this country will favour some form of U-control rather than any of the other systems. For this we must perhaps thank the kit manufacturers who have featured this exclusively, and the technical press who have offered it unceasingly as the ideal method. We fear we must join that number, for to our mind, in common with so many better able to speak with authority, it is the best system. Every other system has some disadvantage, either of structural complexity or limitations in use, the U-control system meets with every need of all classes of models, is adjustable, simple to make, and, given a minimum of care in assembly, unlikely to go wrong. We shall, therefore, concentrate our remarks on this method, whilst inviting the curious by all means to "have a go" at any or all the other methods if they feel so disposed.

Builders will soon appreciate that on the amount of up and down movement given to the elevator depends the reaction of the model, other things being equal. In early models there was a tendency to limit this movement with stops. This is, however, a wrong approach, which places undue strain on the system and tends to distort the elevator and "spring" the connecting rod. A better approach is to design a proper ratio of levers in the control system itself. Radius of the arc through

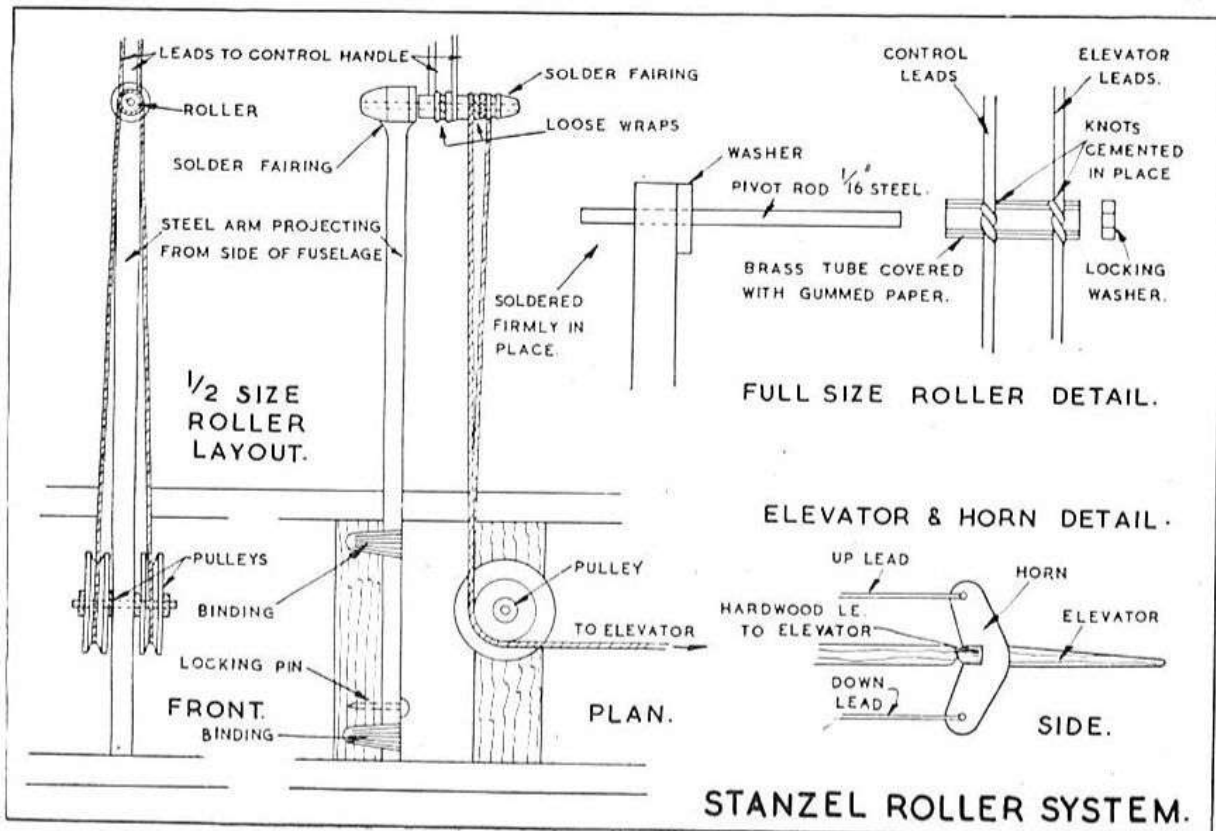

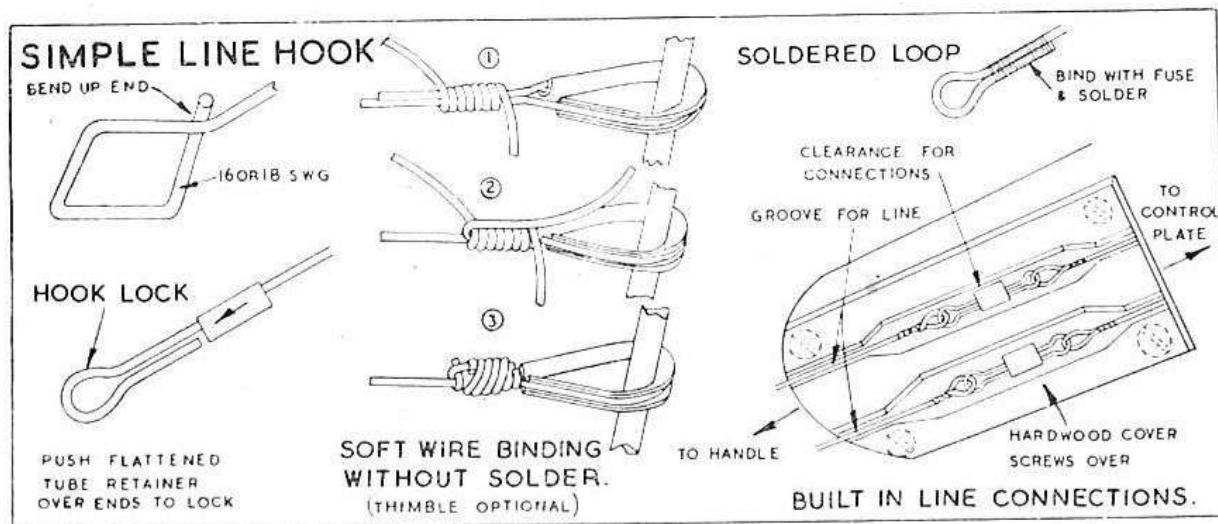

which the control horn moves should be at least  $\frac{3}{4}$  in.; coupled with a radius about the pivot on the control plate to the connecting rod hold of not more than two-thirds this distance. On the control plate the two holes for the lead-out control wires should be spaced very little less than the distance apart of the control lines at the handle. The movement of the wrist in controlling models will always tend to be greater than the movement of elevators, and the lever movement should be reduced by every means possible. This may not always apply with aerobatic flying, but is a point to bear in mind at all times. Care and thought must be given then, to a happy combination of control plate and elevator horn, and not haphazard selection of fabrication of any two shapes that "look right."

Keeping a fixed size of control plate, with holes for connecting rod and lead-out wires suitably spaced, the sensitivity of the elevator will be reduced by increasing the distance of the hole in the elevator horn from the hinge, that is, increasing the radius through which it moves. Reducing the distance will, naturally, have an opposite effect. Most commercial horns have three holes drilled for use according to purpose for which they are used or skill of the user. Thus, with a new and untried model it might be advisable to use the most distant hole, only moving into the next when proficiency has been gained and any faults in the model corrected.

Models will be found with horns attached both above and below the elevator. There is little to choose between the two locations, which will most often be fixed by the design of the model. It is certainly desirable in speed models to have as much of the actuating mechanism concealed in the fuselage to reduce drag, and by varying the position of the horn this can usually be achieved. No such particular advantage accrues with a stunt or sports model where it may often pay to have the actuating mechanism more accessible. Many trainer machines have everything, including the control plate exposed for immediate attention.

Nuts or washers used to retain moving parts in place should always be carefully soldered. Nothing is more disconcerting to find than that a completely concealed nut has unscrewed itself, which usually becomes apparent in flight, and not when controls are being tested. Even a locknut is not to be trusted: solder and be sure. Free movement of all

moving parts is important. Where the push rod, or connecting rod, runs through the fuselage it should be led through holes in the formers of sufficient size to let it pass freely, while a tight enough fit to prevent any appreciable whip when on the "push" part of its operation. In the same way there should be no binding of the lead-out wires, whether led through a guideplate on the outside of the wing, or through holes in the wing ribs, and out through tubes in the wing tips. This latter method is the neater and worth the slight extra trouble involved in all models except the box-car type of stunt model.

Quite a lot of the efficient performance of the model will depend on the lead-out wires from the control plate to the wing tips, the nature of the loop here to which the control lines are attached, and the smooth operation of the whole unit.

At the control plate end there is little to better a right angle bend in the lead-out wire, the short end being pushed through the control plate hole, and a washer soldered in place to retain it. Any unnecessary protrusion of the end should be cut off, lest it foul some other part of the mechanism. Some builders using thin wire bend it right over and wrap it round instead of fixing a washer: this avoids a soldering job, but that is all that can commend it other than for emergency field repair work.

The other end of the wire should be formed into a neat loop, bound with fine fuse wire and soldered. The least amount of solder to flow into the binding should be used—a blob is no stronger, looks unsightly and adds to the drag. Alternatively, a  $\frac{3}{4}$ -in. piece of flattened brass tube can be slipped on the end before bending the loop and this then serves as a neat retainer when the control line loop has been slipped in place. This is used on some well-known kits and is excellent for smaller low-powered models, but not to be trusted for high-powered speedy jobs. Some of the stunt experts bend the ends of their wires into a diamond hook with turned up safety end, rather like a rubber hook

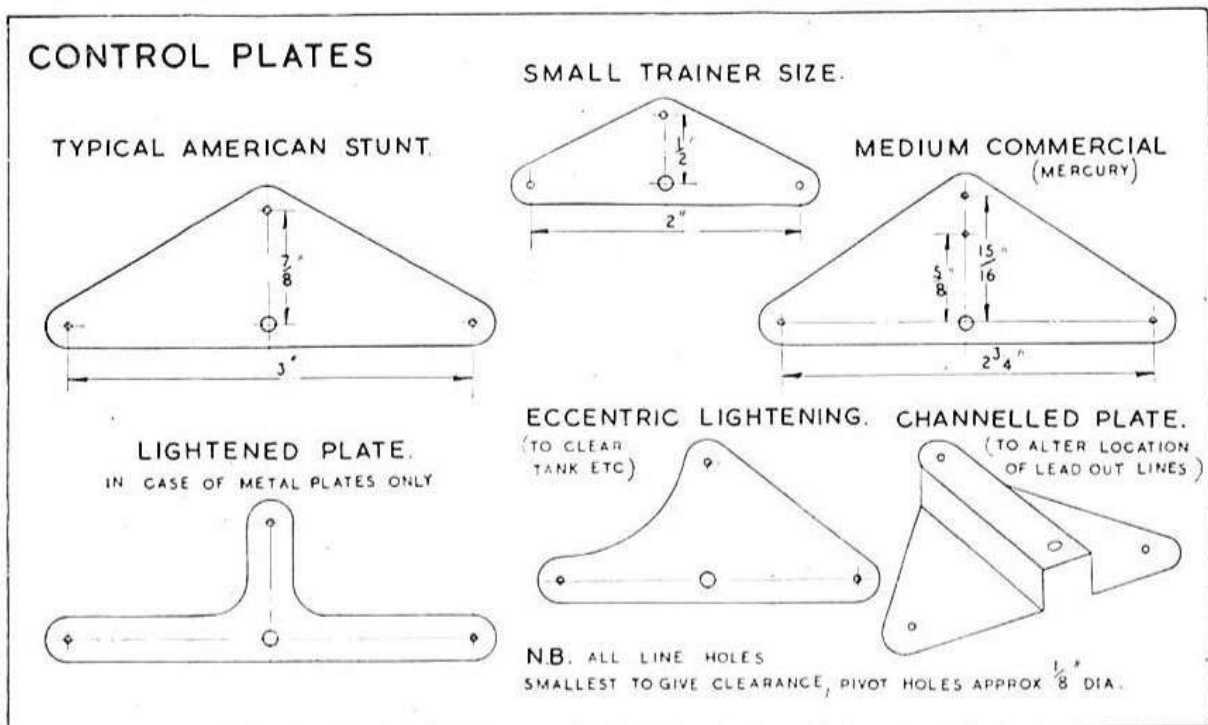

on a duration model. This is satisfactory if 20 s.w.g. or stouter wire is used, with lighter gauges it will tend to pull out when least expected.

Generally, any simple method is sound, provided the amount of strain to be taken is allowed for and, more important this, the attachment of the control wires involves no twisting of them, which will invite unwelcome kinks later on. We have seen an ingenious "corkscrew" type of safety fitting offered as a gadget, but frankly this would ruin the wires in a couple of outings. There is no reason why it should not be used for thread lines. The essence of all fixing methods should be simplicity, strength, and particularly with speed models, low drag.

On the simpler types of models wires will be led out through holes in the side of the fuselage. Such holes should be rectangular in shape along the line of the fuselage, as it will be noted there is an appreciable lateral movement between full up and full down, even in properly designed speed models where the actual elevator movement is small. There is no need to reinforce these openings, and certainly no occasion to bush them as we have seen done, for this is simply inviting them to bind at the first opportunity.

Whether led out above or below the wing, it will be necessary to run these ends through guide holes towards the wing tip. For this, either a ply guide plate or a bent up frame of piano wire serves. It should normally be located at least two-thirds of the way along the wing; its exact position will be determined more by the design of the wing than anything else. There is no critical position, and reasonable variations will not affect performance. Location of guide holes in the plate should be such as to permit a straight line to be drawn through them, the exit holes in the fuselage and the control handle. Any kink in this line will make for reduced smoothness of control and even binding.

If at all possible it is an improvement to run the lines through the thickness of the wings, making a series of holes in the wing ribs to pass through, or, in the case of all wood wings, a channel of sufficient size to give clearance. This can be capped when installation is finished, taking care that surplus cement does not impede free movement. Where the wires come out through the wing tip aluminium or light brass tubes should be inserted, choosing a size that gives adequate free movement without sloppiness.

As most models have little or no dihedral there are no real problems of running lines through the wings, except location of the wing in relation to the fuselage. As there seems a growing design tendency towards mid wing models this makes it all the easier. All types can, however, make use of this method of lead-out, including low wing and high wing designs, though they may require some slight modification of the flat type control plate by bending the ends up or down to facilitate it.

Some designers prefer to have very short stubby lead-out wires, extending only half an inch or so through the fuselage. Control lines are then fed through the guideplate and attached in the usual way. This is not so neat a method as the others discussed and is really only suitable when thread lines are used.

Materials used for control plates include hardened dural sheet, three-ply and paxolin, either bushed or unbushed. Soft metals should

not be used as the holes drilled will tend to enlarge themselves in use by the rubbing of the steel wire connecting rod and control wires. For this reason three-ply may also be suspect, but in practice it works quite well with the smaller size of model. Any excessive movement, that is, play more than a 1/16th in. is undesirable; it may cause elevator flutter at speed and make the model uncontrollable in the air. When found, trace the play and replace ruthlessly, though it means cutting open a beautiful fuselage to do it; otherwise it may be too late for anything except regrets.

The conventional hinge between elevator and tailplane is linen tape, laid alternatively above and below, and stuck on firmly with Durofix or similar adhesive. Silk strips may also be used, or fine mesh muslin. We have also found the stiff buckram-like packing on elastoplast and other self-adhesive wound dressings very suitable. There is an increasing use of hinges that follow the whole length of the join, made by joining two strips of silk or tape along the centre with a machine stitched seam. If the sewing machine operator in the family can be interested this makes a remarkably strong and very neat hinge. With all cloth hinges there is a tendency when the model gets a little older for the material to deteriorate and rip when least desirable. Hinges should be inspected periodically for signs of rot—often brought about by fuel spray—and replaced as necessary. For this reason metal hinges made of wire and brass tube are being used. Care is required in fixing, as there is only a limited amount of gluing area. It will, therefore, often pay to solder a small tinplate lug to the tube to make fixing simpler and stronger. Strengthening the glue joint with a strip of silk or tape to some extent nullifies the advantages of an all-metal hinge.

The ingenious will soon think of many variations on these themes for elevator attachment. A criss-cross sewn hinge of strong thread makes a neat joint, but again the weakness inherent to all perishable materials applies. If ordinary lightweight box hinges of the "cabinet" variety can be obtained they make a splendid job. Many cigar boxes and ornamental cigarette boxes have the very thing, complete with tiny screws which should be carefully removed. Such hinges can also sometimes be bought at shops specialising in accessories for woodworkers, and one model manufacturer at least has just marketed a hinge especially for this purpose.

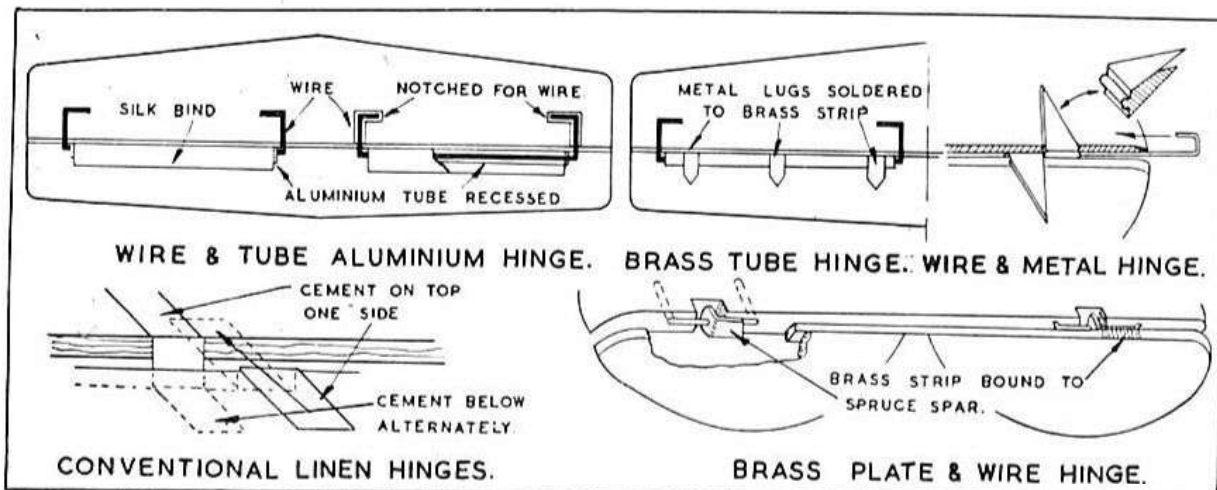



Typical American Speed model in the intermediate class. Uncowled engine suggests that top speed is unlikely to exceed 90—100 m.p.h. Note the absence of fin, and elevator movement on one side of tail only. Spinner appears to have built-in metal ring for flywheel effect.

## CHAPTER SEVEN

### EMPENNAGES

So far, beyond locating the tail movement arm and discussing elevator hinges, we have hardly considered the empennage at all. There are several general points to be discussed before coming down to precise cases. What material shall we use for the tailplane? What is the best shape? What relation in size does it bear to the mainplane? How much of it should be elevator, and how much movement should there be in the elevator? Should it be set at an angle of incidence? On fins, we must consider material, size, and offset—fixed, adjustable, or automatic, and, coming into more advanced realms, whether we even need a fin at all.

In the early days tailplanes were frequently built up, just as in normal freeflight models, but more recently the tendency has been all for simple sheet balsa or three-ply fabrication. This is easily worked, can be readily shaped to a flat plate symmetrical airfoil shape, and its strength can be widely varied by variations in hardness of the wood. Hardwood strips can be added to hinge edges of tail and elevator if additional local strength is needed, or the elevator itself can be three-ply and tail balsa. The only exception to this solid technique is in the case of large lightweight stunt models where tail lightness is essential, when a large tailplane can be lightly constructed of say 3/16th in. square, and tissue covered. It will have little strength and but a short life, but some enthusiasts consider it justifies these disadvantages.

The simplest shape is always the best. Most stunt models employ a rectangular tailplane, with single piece elevator stretching the full span, and projecting beyond the fin for ease of uninterrupted movement. This can be made more elegant by a slight sweepback to the leading edge, and by rounding off the corners, but generally this is the basic shape that will be found most useful.

In the speed department this rounding off of corners will be carried still further to produce an elliptical tailplane, but still using solid construction. Ply will be more popular here in the need for extra rigidity and a firm fixing for elevator hinges.

Relation between mainplane area and tailplane will vary according to the type of model. Though we have seen a figure as high as 35% quoted by an authority, we consider that this is far larger than will ever be necessary with a long moment type speed model. For speed it is more usual to find this area reduced to from 15%-20% of mainplane area, which will give sufficient control, and involve no particular structural problems. For stunt models, again, a practical minimum is 20%, increasing to 30% with short moment arm designs. For biplanes

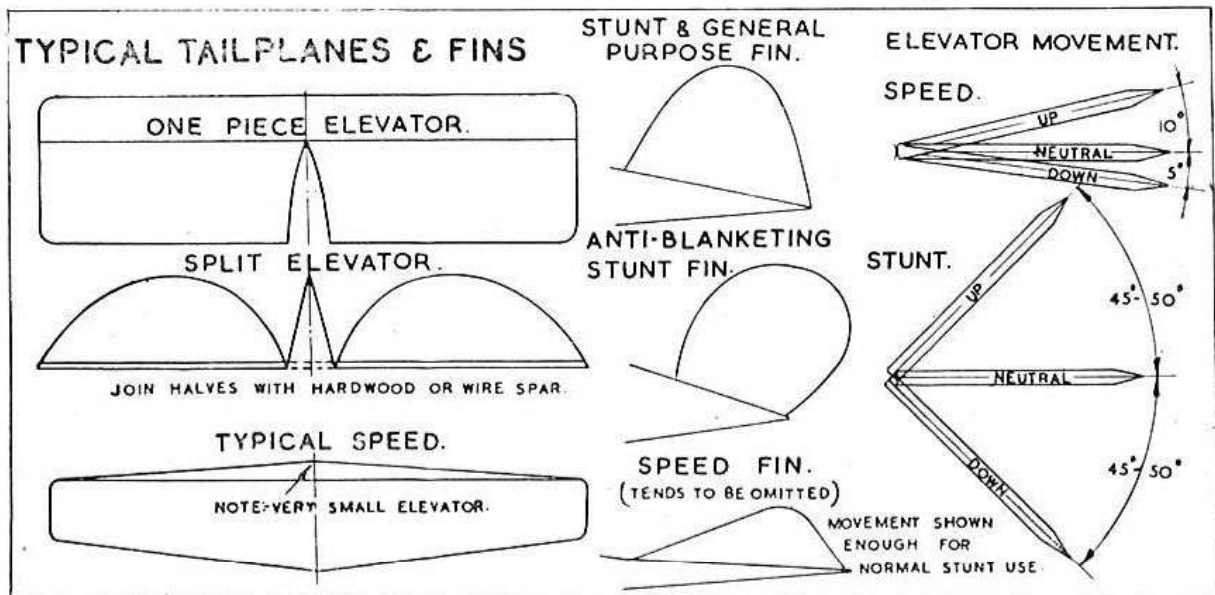

the relation is judged from the total area of the two mainplanes, and the low limit size chosen, unless the model is of unusual proportions. For extremes of moment arm the figures given can be slightly increased or reduced, if considered essential to good design, but less trouble is likely to be experienced if they are adhered to rigidly.

Most scope is offered in deciding the proportion of the tailplane that is to be elevator. As we have seen in the design section, this figure can rise as high as 60% (which is latest American figure) for stunt models, but the comparative beginner will be best served by keeping within the 50% margin, which gives an immense amount of control, well able to manage the most ambitious flight pattern. Just as stunters see how much they can move, so speed fliers must see how little. It should never be necessary to have more than 20% of the tailplane devoted to movable elevator; in fact, it is far better to think in terms of 10% as a normal maximum, and consider very carefully before increasing it. The speed model will be flown in constant height flight circles and the only trim required is in keeping the job level in a wind, and in take-off and landing. The least that will do this work should be chosen. To give some idea of just how little will do for speed flying, a number of modellers have flown their models with fixed controls R.T.P., and a number of designs have been published for this kind of flying. When there is no wind it should be possible to fly any *well designed* speed model like this.

How much movement should we incorporate in the elevator? For speed models a total range from full up to full down should not normally exceed 15°, with up having 10° and down 5°. Always give more up than down so that response is quicker in emergency; it will be easier to keep out of trouble in an upwards direction than downwards, and it is comforting to feel that a quick flip will correct an unwitting dive in time to avoid a prang. For stunt models we can really put in some movement; 90° full range is quite a good normal maximum to bear in mind, with the movement split equally between up and down, for the model will be flown, we trust, as much inverted as right way up. We have seen even more movement allowed, but the elevator is then becom-



ing virtually a wind brake, and may well cause mushing and even stalls if given full movement except at top speed.

There can seldom be any reason to set the elevator at any angle of incidence : it will be hard to go astray if always placed at  $0^\circ$ , as nearly as possible on the thrust line in the case of both speed and stunt models. There will be occasions with speed designs where its location can be defended elsewhere on structural grounds, for example, to avoid damage in a belly landing, or to permit all enclosed control operation.

Whilst accepting the single straight through type of elevator as the most desirable, there will be occasions where a split type will be required. This applies mainly to speed models, as the divided type permits easy installation of all enclosed elevator horn and connecting rod. Care should then be taken to be sure the two parts are strongly attached in the same plane. This can be accomplished either by a hardwood strip cemented to the edges of the two halves, or by a steel wire joining brace. The latter is stronger, but more inclined to buckle. The hardwood or dowel attachment is more rigid, but will break off under strain. Some very fast models get over the problem by having a movable elevator on only *one side* of the tailplane. As the model cannot get out of the circle it does not matter if the elevator movement tends to pull it out on the wires. For other than fast models, with a high degree of centrifugal pull, this practice is not recommended.

Another recent innovation, pioneered by Garami, is to have a fixed tailplane on speed models and secure control by movable ailerons in the trailing edge of the mainplane. This permits shorter connecting rod, and smoother response, though not so positive as in conventional layouts. It also spoils, to some extent, the smooth sweep of the mainplane. We have not heard of it being fitted to any really successful design, so must consider it experimental only for the present.

There can be no reason whatever for a detachable tail unit in a model designed for exclusive control line use. There are one or two so-called combination kits on the market with interchangeable free flight and control line empennages, where loose fitting is necessary, but such models are compromise designs at best. No matter how well secured there is the probability of movement in flight with jamming of controls, plus flight to flight changes of tail trim through casual assembly.

The fin enjoys a dual function on control line models. By sturdy construction it can protect a comparatively vulnerable tailplane from damage in a noseover landing, and in flight by offsetting it can maintain line tension. Area should be 10% to 15% of mainplane, reducing to 5% or less with speed models.

For the former reason the trend is now to a solid fin, though not quite so general as the solid tailplane. If a built-up fin is decided upon it is a good practice to see that it has a sturdy vertical mainspar to take any unwanted landing shocks. By far the greater number of models use the fin to keep the model constantly trying to turn out of the circle, thus preventing that horrible feeling of helplessness when an unruly plane is coming in on the line faster than the operator can step back and control it again. The slower the model the more offsetting will be required, but it is not necessary to offset the whole of the fin. About

one-third only at the rear can be offset to turn the plane out of the circle, according to rotation of flight. It should be offset anything from  $5^{\circ}$  to  $15^{\circ}$ —finding by experiment the least offset that will do the job efficiently. Too much makes the machine crab, and with speed models materially reduces speed. If the whole fin is turned—and this will be usual with built up fins—then amount of offset can be reduced to as little as  $5^{\circ}$  with good results.

For small scale models where an offset fin would destroy something of the scalishness we have found cambering of the fin to a Clark-Y or similar airfoil does the trick very well. It does not seem very efficient, however, with the larger engines and heavier models.

Modellers flying their own designs will probably favour an adjustable fin, at any rate in their prototype trials. Hinges should be stout enough to resist the airstream striving to straighten them in flight, and owing to greater speed must be stiffer than similar free flight hinges. Tin can metal or brass wire will be found simple and practical. When the ideal setting is found, cement the offset, and carefully measure angle for future reference.

As the offset fin is only necessary to prevent the model coming in on the line, some ingenious builders have experimented with an automatic rudder, which only turns when the lines slacken. This is effected by having a sliding control plate, normally held in a central position by the pull of the lines. If the pull slackens then elastic bands act on the plate, which in turn allows the spring loaded rubber to swing over. As the lines take up the strain again, the control plate centralises and the rudder returns to neutral. For the gadget-minded it is worth trying, but seems an unnecessary complication to a simple model and an insecure one to a really fast machine.

High speed devotees have considered this fin bogey very thoroughly, and decided to do away with it altogether. They reason that at speed the centrifugal pull on the lines will keep a properly designed model taut, so the problem only applies to slower take off and landing speeds. With a really stable dolly designed to carry the model until it is well up to its flying speed before release, the take off problem is solved, while the machine can be whipped to keep control in a dead engine landing. Hence a number of dolly type speed models will be seen to lack any fin. To a practised flier there are no particular flying headaches, whilst perhaps as much as 5 m.p.h. has been added to top speed by removal of an undesired piece of drag.

Fin shapes are usually conventional and unimaginative, taking the most practical lines suited to the design. Thus we find them practically straight on the leading edge, and gently curving into the lines of the tail at the rear, with a convenient sweep joining the two parts. Or, more utilitarian, with all lines straight and only the corners slightly rounded off. An exception to this was noted in Pete Cock's 1948 Gold Trophy winner, which had a distinctive bowed trailing edge. In conversation with this acknowledged low power stunter, he claimed that such a shape prevented any blanketing effect when in the transition position between upright and inverted. We later had occasion to try

the idea on a small Mills powered model and found it much happier at the controls, so offer it to all small slow-flying model designers.

Some models, particularly with twin boom layouts, have incorporated twin fins. This is doubling up on a nuisance and suggests that twin booms are bad design, except in scale models. With such a layout flying is more by instinct than eye, for it is quite impossible to see the elevator unless it is big enough to project beyond the fins. This twin boom idea appears in one of the A.P.S. designs, the Tyro Trainer, and we were puzzled for some time as to why the designer had used it, for it is not a twin boom job, and it seemed to have no logical place. On test the model justified its design: the twin fins added to directional stability, and steady pull on the lines, while the inability to see elevator encouraged instinctive control and smooth movement. As the design is a speed *trainer* this forcing of the pilot to act instinctively and not watch the controls—which can hardly be seen that clearly at speed anyway!—warrants further investigation of beginners' designs to make them do the right thing because they have to, instead of just telling them.

Carrying this analogy a step further, it remains to consider whether the recommended practice of painting the elevator a bright colour so that it can be seen is good advice. Frankly, the only time when seeing it matters is at take-off testing, and the helper can surely be relied upon to give the cautionary, full up, full down, as the pilot waggles. At slow speed the elevator can certainly be seen, and its position checked visually, but most reactions become purely instinctive, and it is a poor flyer who does not know where his controls are at any given moment. We have decided against the practice, and confine ourselves to a bright colour for the whole aircraft, with a contrasting underside in the case of models intended for extensive stunting, for one can almost forget which way up the machine should be and attempt an upside down three pointer.

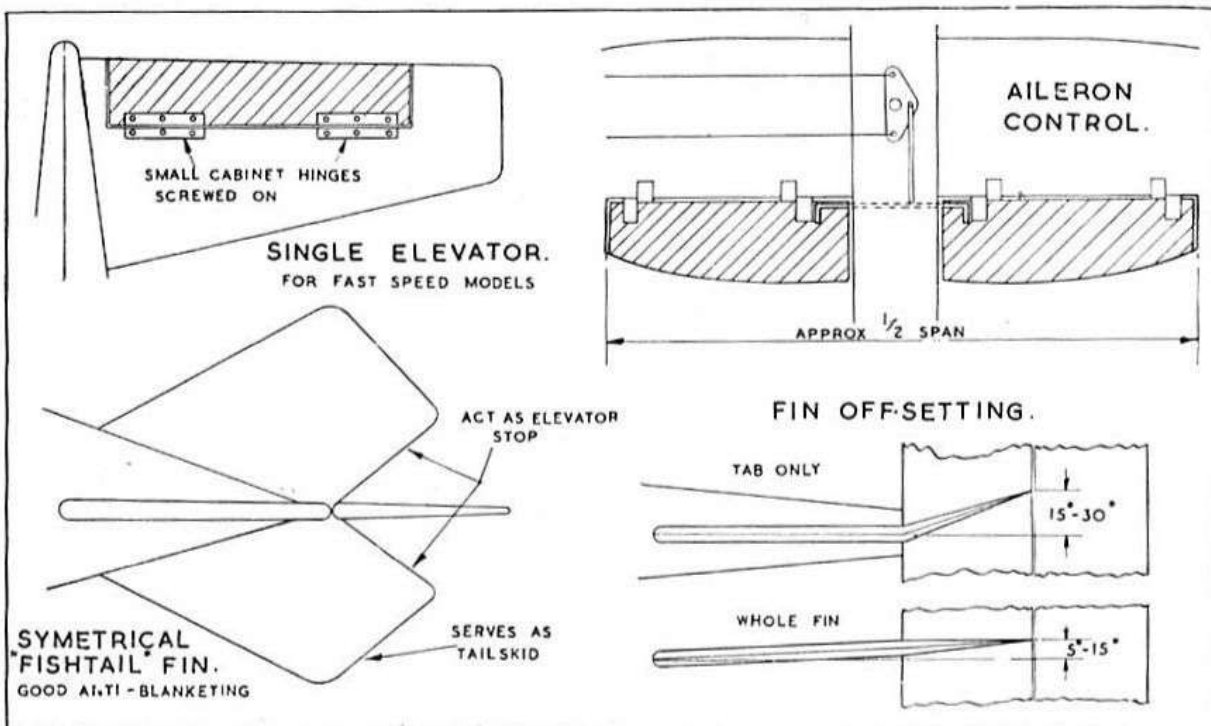

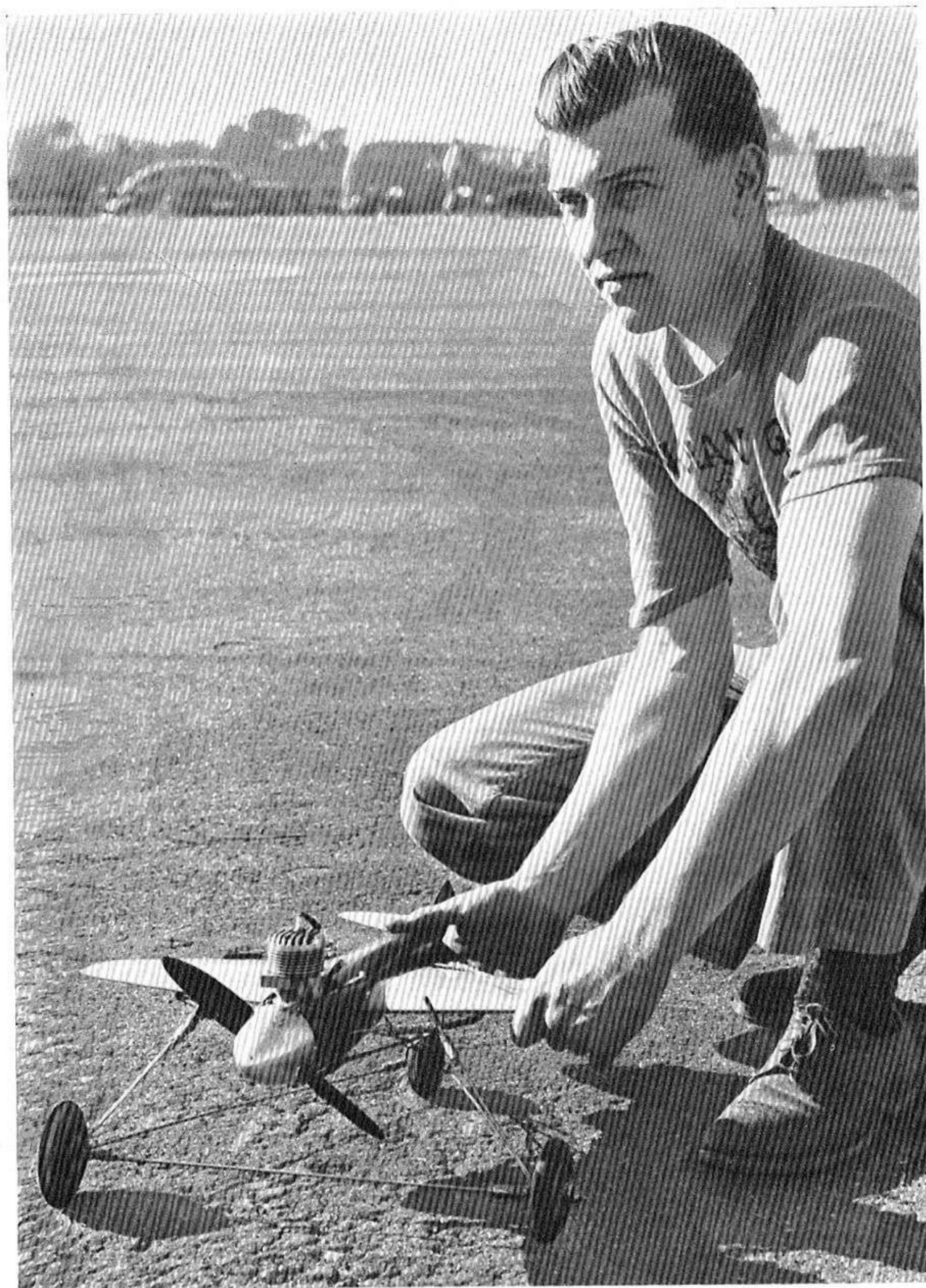

Speed model mounted on dolly. Features to note are wide spacing of front wheel section intended for concrete or tarmac take off, and simplest possible bracing compatible with strength.

## CHAPTER EIGHT

### UNDERCARRIAGES AND DOLLIES

As most control line models are functional rather than beautiful, it follows that undercarriage arrangements will be such as to do the job required and no more. The obvious reasons for an undercarriage at all are to give the model some means of running along the ground until flying speed is reached, and to serve the same purpose in reverse when landing. To these may be added the need to protect the propeller at all stages when the model is not in the air, added side area low down provided by the wheels, and added pendulum stability added by the weight of wheels and wire structure.

There are certain differences between the design of a control line undercarriage and that of a free flight model. In the latter case there is usually a secondary attachment to the fuselage behind the main legs to even out the backward landing stresses, when the machine must land unassisted by a pilot and with engine off. A control-liner is, normally, landed smoothly by an experienced or lucky pilot, or simply whanged into the ground. No harm is done in the first instance, but in the second legs are invariably bent for all their inherent springiness, and any wood fairings damaged. These are therefore usually omitted and we have instead a stark single wire leg without any secondary attachments, which are more trouble than they are worth. A bent leg is no worry on the field as the wire can be straightened in the hands and all is well. Any complications make for trouble and are best left off.

As a single wire only is used it follows that it must be stout, of  $3/32$ nd or  $1/8$ th in. diameter best piano steel. It is bent in a single piece with a V or U shaped portion at the centre for attachment to a bulkhead in the fuselage. This bulkhead must be of ply, not less than  $1/8$ th in. thick, and the wire firmly bound to it with fuse wire and the joint soldered over. Thread binding will be strong enough only for the smaller models of up to 2 c.c. capacity. A simpler and equally effective method is to use J-bolts, either bent up and threaded by the builder, or bought at the model shop for a few pence. Again a strip of tincan metal can be cut and bolted to the bulkhead to make a firm fixing.

We have recently made full use of small bonded paxolin boxes available to take the more popular wire gauges. These are so strong and afford so firm a fixing that they have often survived to play a useful part in several models when all else has gone. The undercarriage need not be bolted in, but is simply sprung in place. In the case of bad bending it can therefore easily be removed for more extensive straightening than the usual hand bending back.

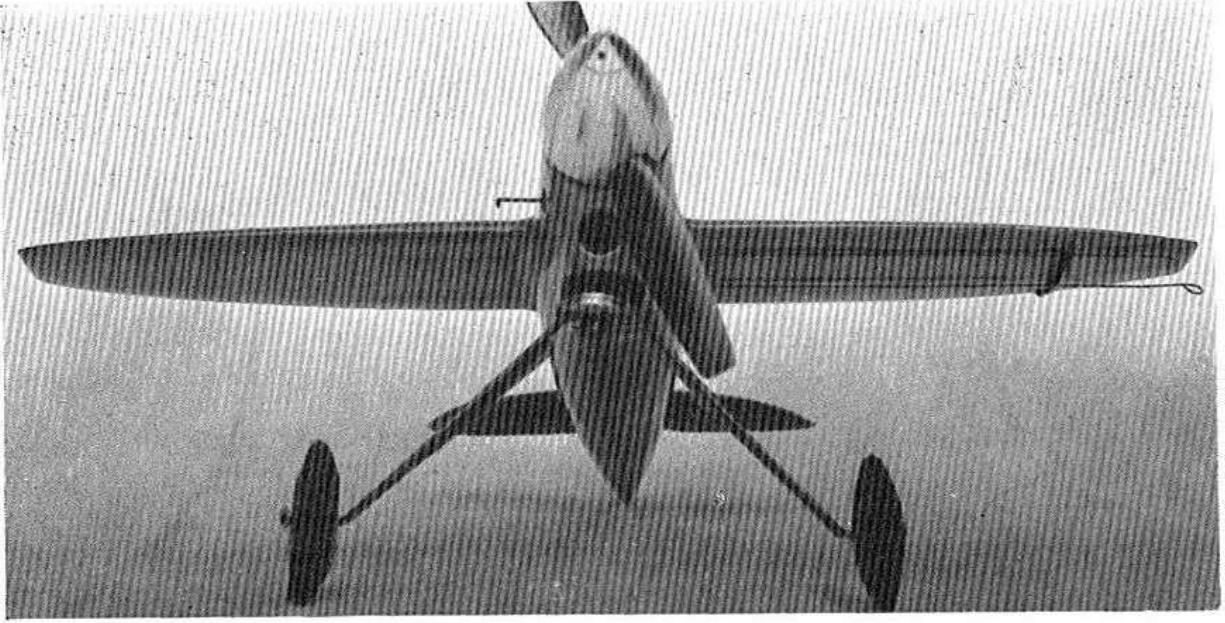

A simple training model that is nevertheless quite graceful and finished with such refinements as enclosed engine and prop spinner. Simple unbraced undercarriages of adequate thickness are the general practice for this class of model.

Legs should be bent slightly forward, with the attachment bulkhead just forward of the C.G., or even actually on it, and be long enough to give, say, up to one inch clearance for the airscrew when the model is in its normal posture just prior to becoming airborne. Their track should be about 80% of the airscrew diameter. Too wide a track should be avoided, as it provides an unnecessarily large turning moment where one wheel is out of line.

With scale or semi-scale models builders will wish to follow the prototype undercarriage arrangements, and in this case some fairing-in will be necessary, but should be so carried out as to allow the maximum possible springiness in the steel wire to be retained. Added strength will be given to legs normally located outboard of the fuselage in the underside of wings if they are still bent up in one piece with the connecting wire running through the fuselage, and firmly bound or clamped to a ply mainspar. Advanced builders have developed clever retracting mechanisms that work both up and down by means of a third line, and these certainly add to the realism of scale model flying. They have no justification, however, in any other phase of design.

The uses of a fixed undercarriage cease, except for its stabilising value, once a model is airborne, and builders have been quick to seize on this aspect. Nearly all contest type speed models and some stunts are designed to have either a drop-off undercarriage, or to take off from a three- or four-wheeled "dolly," which can best be described as a "take-off truck." At the end of the flight the model must, perforce, make a belly landing, but in reasonably skilled hands this will not do any damage. The underside of the fuselage is suitably reinforced in some cases with a wire or metal skid, metal sheathing, or simply a piece of hardwood strip let into the surface. The airscrew has been previously fixed on the shaft so that when the engine cuts it will lie horizontal, that is, in line with the wings. For added protection some airscrews even have folding blades, a refinement that saves much extra work or

expense. This lack of damage presupposes that landings are made on turf or dirt surfaces ; concrete or tarmac will score even metal protectors.

As a first essay at detachable undercarriages, the beginner is urged to try the two-wheel drop-off type. He may find this so satisfactory that he will not want to try any other method, though there are disadvantages and risk of a noseover when fitted to a very fast model, that requires high take-off speed, operating from somewhat bumpy ground, such as usually seems to be the venue of the average contest occasion. The construction of such a unit is very simple. If the paxolin box already mentioned is used, it is only necessary to bend in the U-shaped retaining portion of the undercarriage to make it a drop-off fit in the box. Immediately the model becomes airborne it will drop off.

Care should be taken when first trying such a modified take-off, for the removal of the weight of wheels and wire, probably from a point not exactly on the C.G., will give the machine a violent up surge, and over-correction at this point must be guarded against. Where models have been specifically designed for such tactics the undercarriage should be located exactly on the C.G., thus avoiding this violent change of trim. All that will then be noted will be an immediate increase in speed.

Most varieties of this technique embody two separate prongs in place of the U-shaped tongue of wire. The legs should be bent up in one piece as for a conventional undercarriage, and two cross pieces bound and soldered in place. The bar of the U can then be cut away and the prongs finished smooth with a file and emery paper. Brass tubes that provide a free sliding fit should next be cut to slip over the prongs, and, using them as locating guides, the tubes should be soldered to a flat metal plate for attachment to the appropriate bulkhead. When finished they will probably be found to work very well tested manually, but apt to stick in actual operation. This fault can be cured by steadily filing away at the prongs until, if the model is held in the hand and thrust forward quickly in a flying attitude, the legs will then freely detach themselves. Before flying both the tubes and prongs should be oiled to assist free detachment. It will be noted that expert flyers are most particular about this, oiling the undercarriage as often as they fill the fuel tank, and testing legs before every flight.

Drop-off undercarriage coming away from Aeromodeller design Crackerjack, during its test flights.

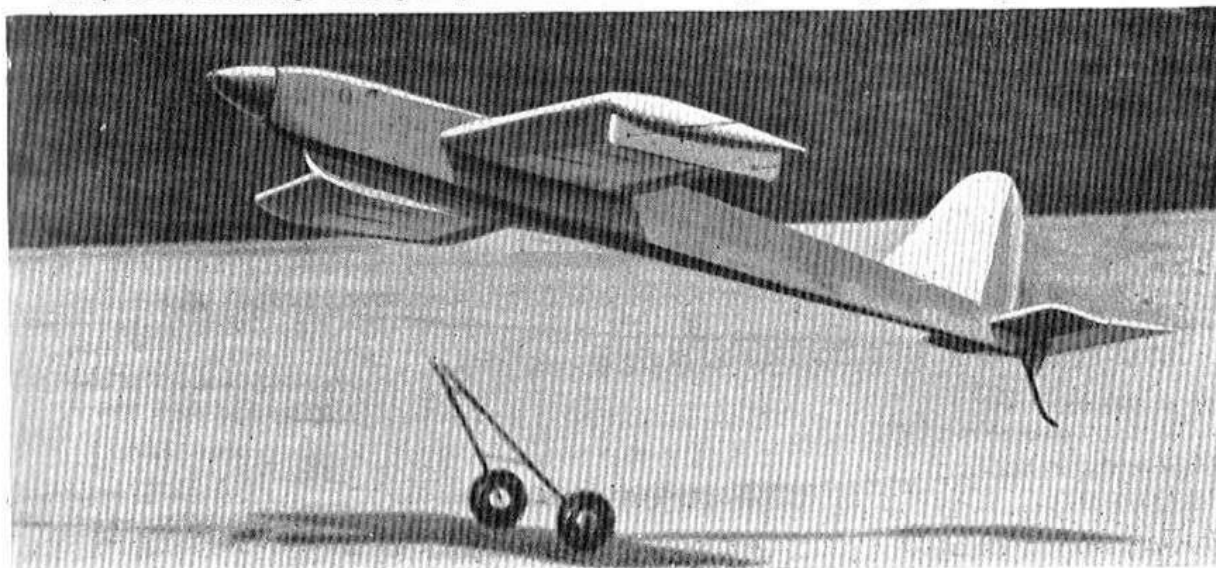

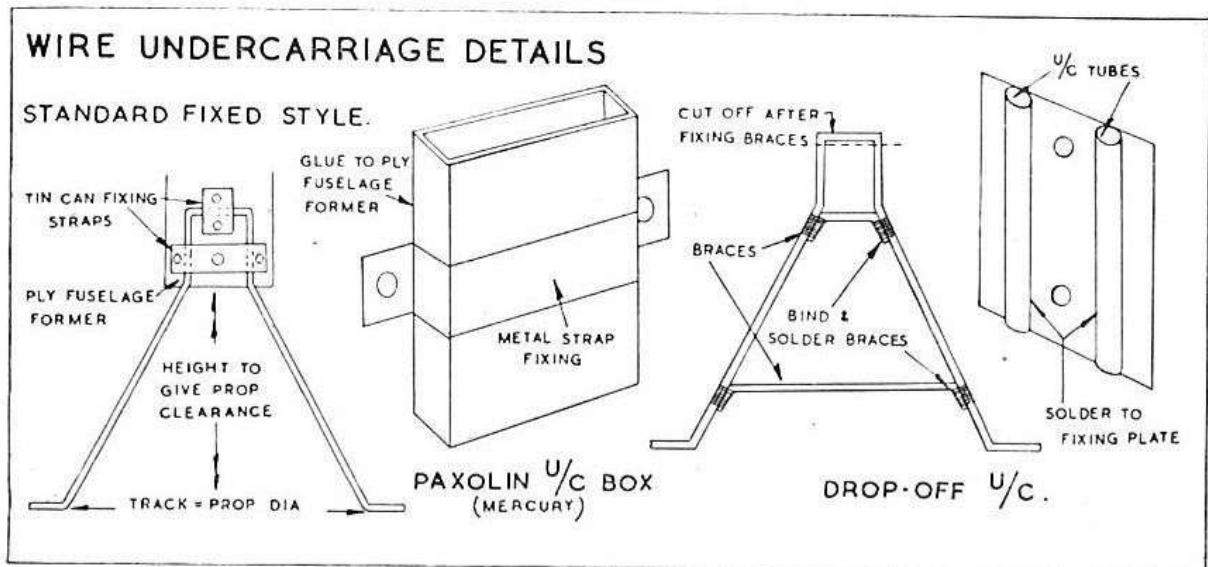

Some experts have devised a light spring wire "whisker" which they locate on the leg cross-bar which has the effect of forcing out the prongs on the model becoming airborne. This seems to be only a complicated way of curing a fault that should surely not have been allowed to arise for long. However, as experts have used it, we offer it for what it is worth.

So far we have not considered the type of wheels that are to be used with these undercarriages. Many firms have now produced excellent streamlined rubber wheels in the more popular sizes, bushed with brass or dural hubs. There is little to choose between the makes offered—all seem good value for the money. The better wheels have firmer attachment of rubber to hub and are less likely to strip off in use. With all types it is essential to see that they not only run freely and true, but are firmly attached. A washer should be pushed on to the axle before the wheel and firmly soldered in place, binding behind it with fusewire to give soldering area. The axle must be well cleaned with file and emery paper until it shines, and the wheel then slid in place. A further washer, again reinforced with a little fusewire then locks it in place when soldered. Steel is much easier to solder when using an acid agent such as Baker's Fluid, but to avoid rust the soldered joint must be thoroughly washed with warm soapy water or soda water to act as a balancing alkali to the acid. This prevents rust that will otherwise quickly appear. The soldered joints are finally finished off neatly with a file, a drop of oil added to the axle, and the job is ready for use.

Some of the smaller kits provide hardwood or even metal wheels in place of rubber. There is nothing really wrong with their use, except that the wood may split, and the paint on the metal soon wears off, making the model look somewhat shoddy. For initial flights they will serve well enough.

We have spoken so far of solid rubber wheels only. Air wheels are not looked upon with favour by the best people for fixed or drop-off undercarriages, as variations of inflation may destroy tracking at take-off, they have much more drag in the air, and their natural bounce may turn a nice three point landing into an ignominious somersault. There are occasions when their use is justified, such as where take-offs



are contemplated from rough and grassy areas, and their added cross-sectional area will help to flatten the surface and prevent take-off noseovers.

Finally, we come to the dolly. Here good strong construction is possible, and airwheels of ample size come into their own, for most speed flying will take place from turf, where landings can be gentler. They are equally good on concrete and tarmac surfaces.

Dollies are usually three wheeled, with two wheels in front and one behind, though four wheeled dollies are also used sometimes. Apart from the wheels they complete their truck nature by a cradle for the fuselage, and extension pieces supporting the wings. In some designs the fuselage cradle is omitted in favour of prongs entering the underside, which makes for more positive location. It is important that their construction is such as to retain the model securely on its bed without shifting, in spite of bumps on uneven ground, until sufficient speed has been attained for it to fly off safely. Only too often we have seen good models damaged by a premature departure from a poorly designed dolly.

It is not good enough to proceed with construction on the lines of a rather elaborate undercarriage. Such a procedure will soon land the builder with what looks like a tangle of steel wire knitting! The whole job must be carefully planned: the separate parts required carefully bent to size, and matched with any opposite part. Assembly is virtually impossible without some form of simple jig. We have found a short length of planking about six inches wide by an inch thick most useful in this connection. Assemblies can be pinned to it with ordinary carpenter's staples where they are perfectly secure during the binding and soldering operation. A right-angled joint can be well supported on the surface of the plank, with the upright part stapled to the side, whilst a holding jig for any other angle can be made in a few moments with a plane on any other side.

In the effort to be symmetrical some dolly designers fix the rear wheel in a U-bent axle. This is always difficult to bend, as the wheel must be slipped in place before the second bend is made, and never

Outboard wire undercarriage on model of semi scale appearance. Whilst essential in true scale models there seems little justification for its location in this instance.

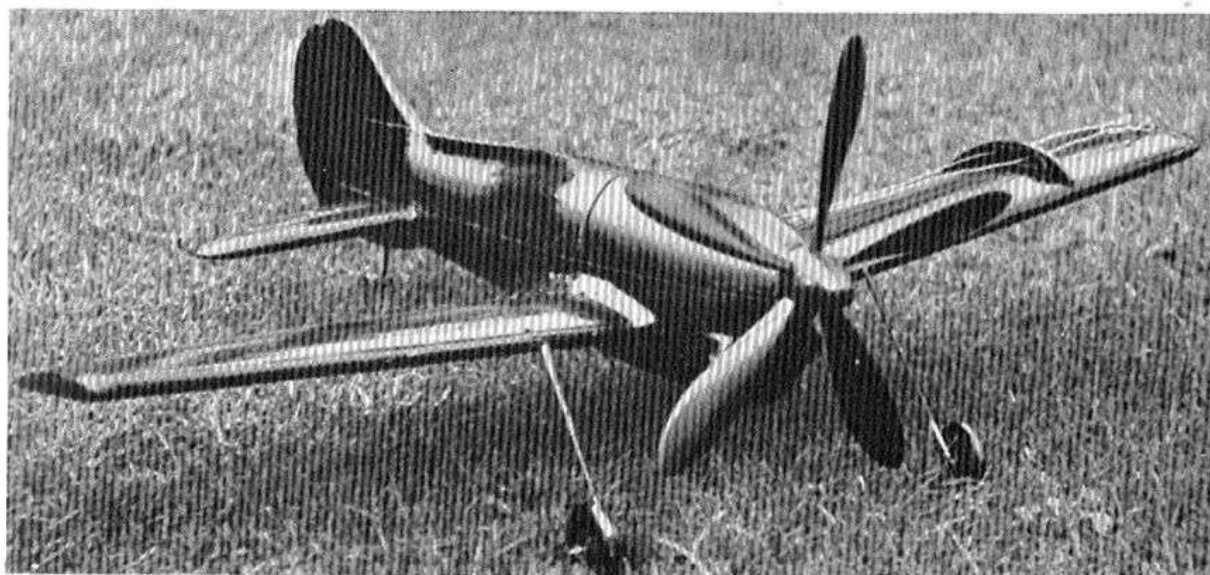

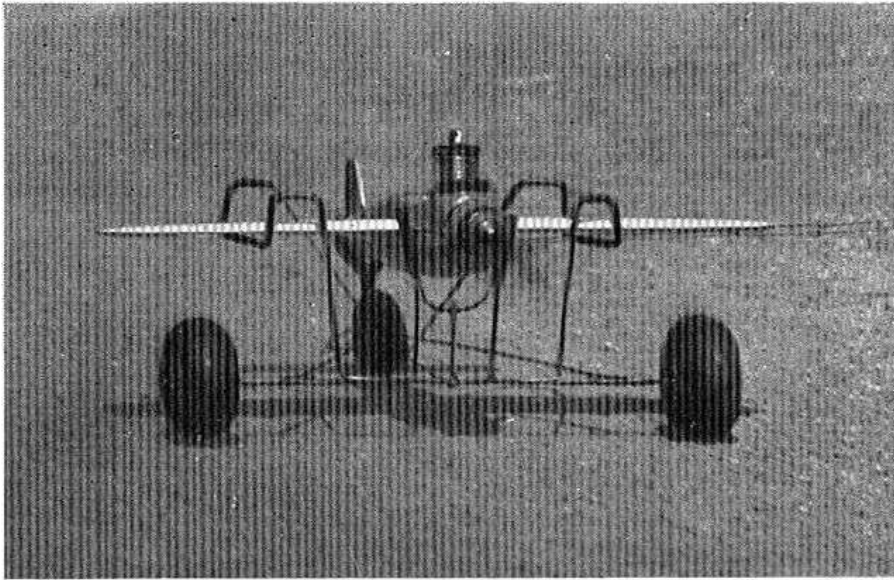

Tricycle dolly fitted with airwheels for grass or rough ground take-off. Compare the more complicated bracing here with the simplicity shown on page 66.

A scale dream! Fully retracting undercarriage and drop-off bombs featured in one of F. B. Thomas's models. This degree of realism is at present beyond the average British control line enthusiast.

seems to track up without immense trouble. It is better to have an open-ended rear axle, similar to the normal front axle, as all bends can be made *and adjusted* before slipping the wheel in place.

It may be thought that binding of say three 1/8th in. wires together at a junction will make an ugly bulky joint. It will be bulky, but need not be unsightly if the fusewire binding is laid on neatly, and a restrained use of solder made. After a joint is effected between the surfaces concerned no amount of extra solder makes it any stronger, so that nothing is gained by slapping it on. We have found that 15 amp. fusewire is the best for dolly use as it is thicker and pleasanter to handle than the lighter 5 and 10 amp. grades which do so well for binding control wire loops.

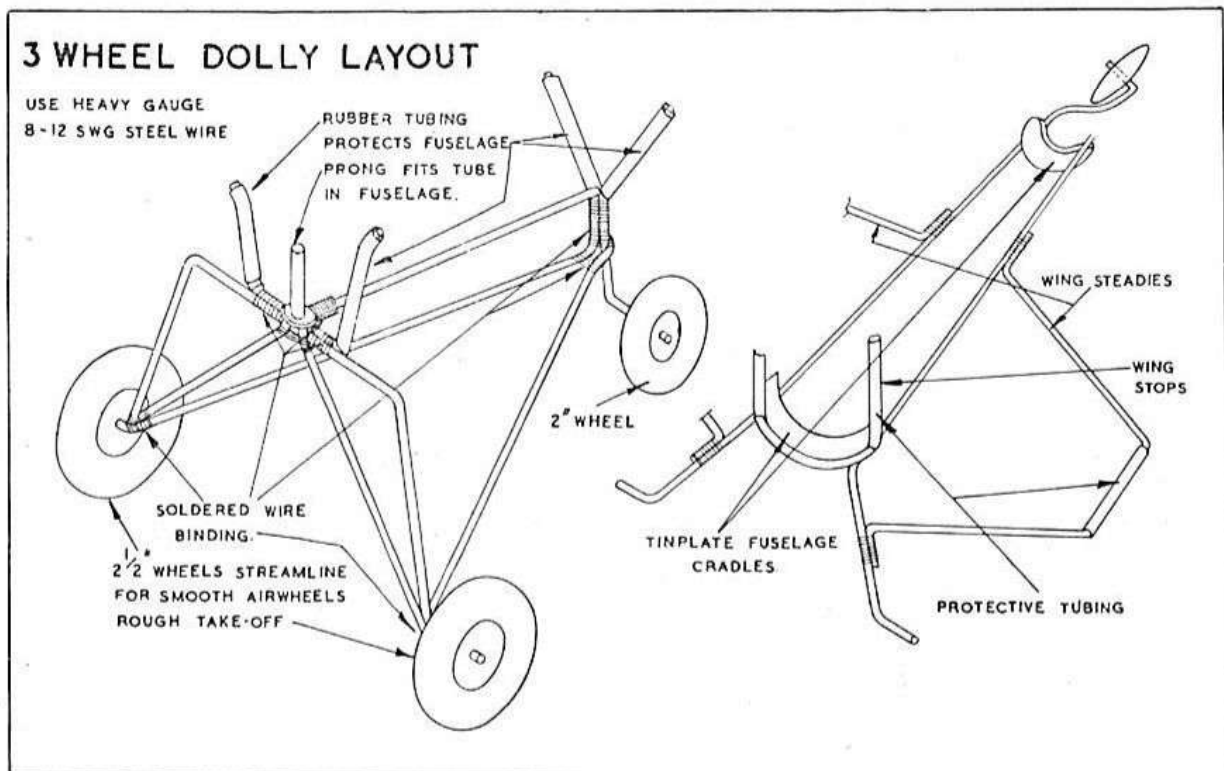

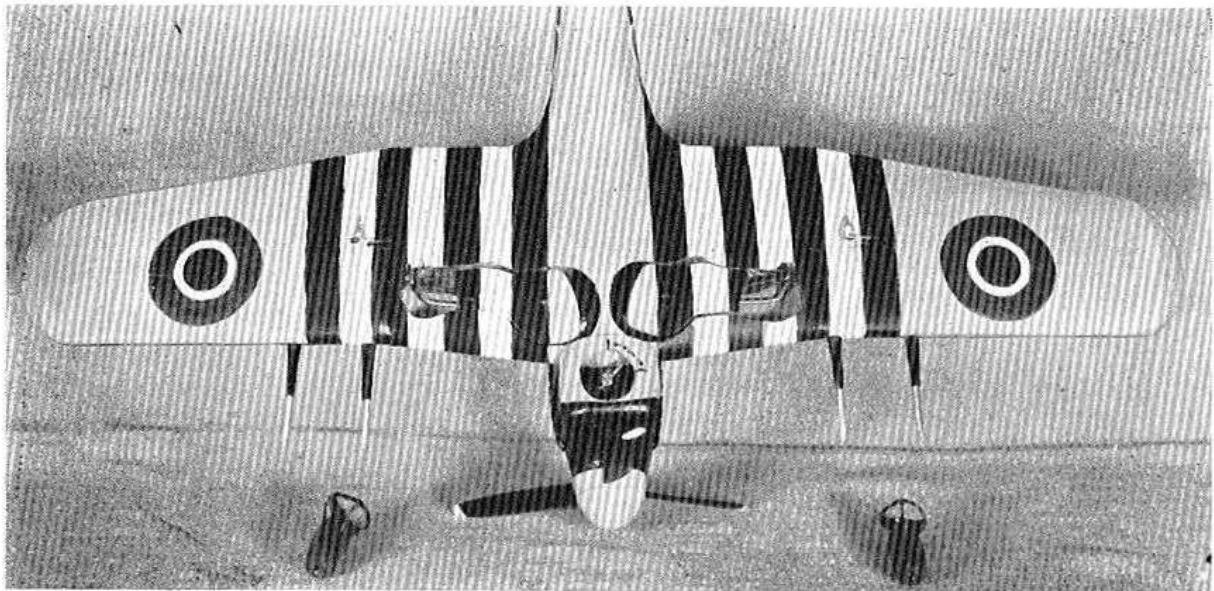

When the dolly is finished it will be necessary to bind the parts touching the model with rubber or similar material to prevent scratching the highly polished surface. In some cases it may be possible to have slipped bicycle valve rubber in place prior to closing access by a soldered joint; other parts, such as the wing locating pieces, will still offer convenient slide-on points. Where it is not easy or possible to have rubber tubing in place, a neat and efficient covering can be given with quarter-inch rubber strip wound round in spirals. The beginning and end can be touched with rubber solution to hold in place, and really painstaking builders may even rubber solution the spiral edges. For final security a neat thread binding at each end finishes off the job. Binding with insulating tape, old bits of rag, and so on, such as we have seen, is slovenly and adds nothing to the flyer's reputation. Remember, the dolly is on the ground most of the time, and spectators can inspect it more carefully even than your model; moreover, it will have no performance figures to give the lie to unsightly finish!

All drop-off undercarriages and dollies should be attached by a third thread line to the pilot to avoid injury to spectators. Although not so necessary to do this when flying without a crowd, it is a good habit to acquire. Should you decide not to bother, do remember to paint the drop-off parts with a vivid splash of red or other bright colour. We have spent twenty minutes or so trying to find a drop-off undercarriage not so coloured in the grass—and then did not find it.

The practice of fitting rear skids would appear to have only the practical value of protecting tail and underfin from wear on a hard take-off strip. In use they are more trouble than they are worth, catching in grass and interfering with proper tracking. Except, therefore, when they are essential for protective or mechanical reasons they may best be omitted.

Before leaving the subject of undercarriages, we should mention in passing the omission of any undercarriage at all. The model is then hand launched by a helper as described in the flying chapter. Such simplification is usually found with the smaller sizes of stunt model, or where access to decent take-off surfaces is impractical.

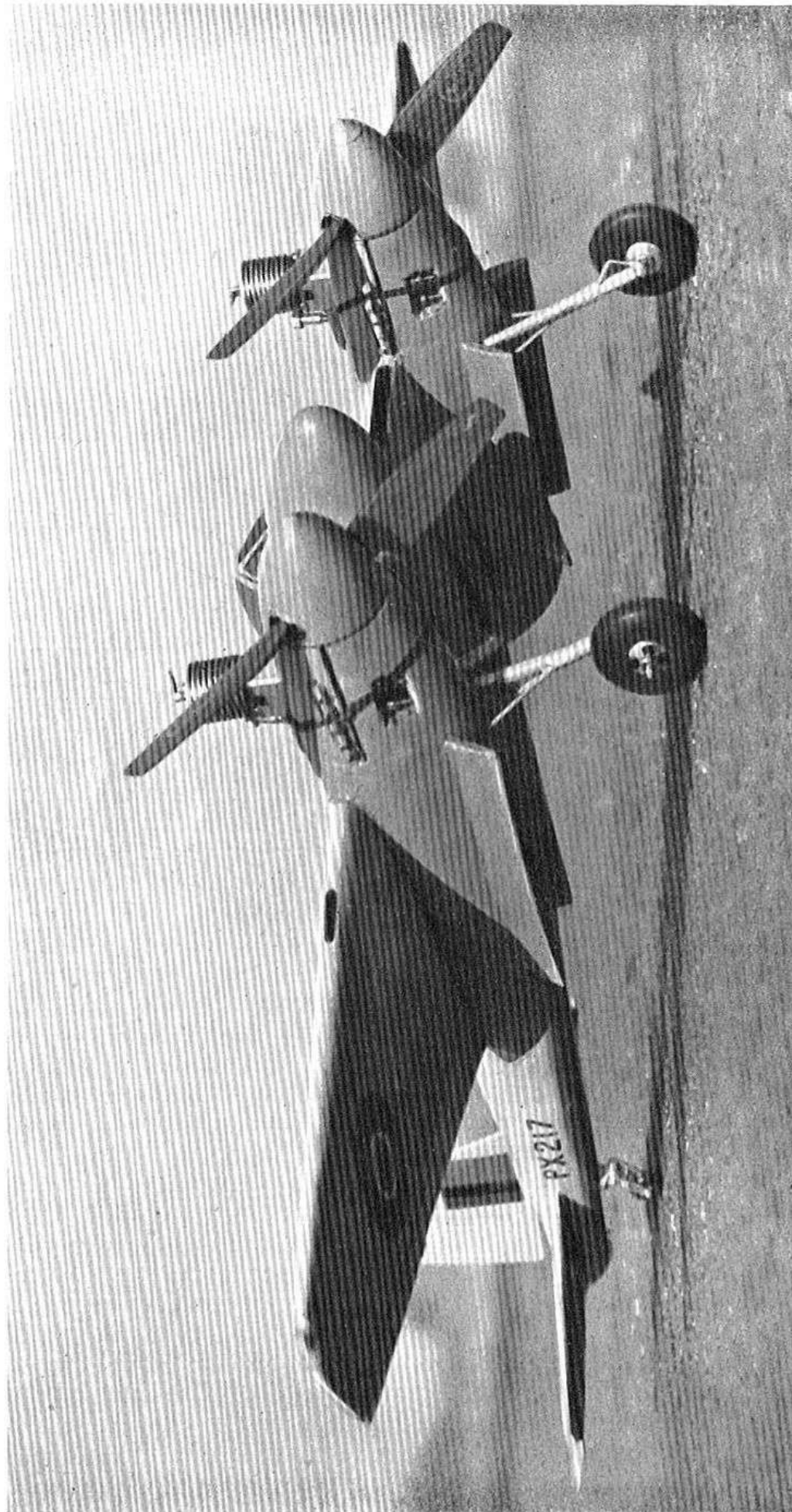

A control line model of the D.H. Hornet. While this machine's scale appearance is marred by the protruding cylinder heads—which would have been far less obtrusive if inverted—and the ugly exposed fixing bolts, it is nevertheless a very praiseworthy and successful effort to produce a flying twin engined job. Later versions will no doubt devote more attention to scale looks.

## CHAPTER NINE

# ENGINES, COWLS, TANKS, FUEL AND STARTERS

WHILE design of airframe and engine as an integral unit is essential to really high performance, this is sometimes a counsel of perfection, impossible both in full-scale and model projects. There is no need, however, to despair; in the full-size world, for instance, the German FockeWulf 190 will long remain a classic example of the unsuitable, or even somewhat outmoded, engine so brilliantly incorporated into an airframe design that it equalled and often surpassed contemporary designs that had suffered from no such handicap. The model builder will, of course, always endeavour to match engine to airframe to come as near this ideal as possible, but, unless he is able to own a number of engines, there must be a degree of compromise if he takes an interest in both speed and aerobatic flying. Most heart-burning will come where, for example, some attractive American design is built, but no equally attractive hot engine is available. Frankly, this is bad planning—first have your engine, then, even if you do not propose to design an aircraft for yourself, you can at least secure plans or a kit specifically produced for that power unit. Only in that way will the best be got from both. Whilst on the subject of one engine or many—obviously it is better to have several power units if the pocket permits, but never quantity at the expense of quality! If you can afford two average engines or one really good one, our advice is go for the good one. Though we hasten to qualify that advice by adding, provided you can guarantee it “a good home.” In the novice state it is perhaps provident to have the eggs in more than one basket—then later on sell these engines and get the very best you can buy.

What constitutes a good engine? Literally every engine on the market has had one or more models designed round it, and manages to fly them—but that does not necessarily make them “good” for control line flying. We must necessarily mention a number of engines, but this by no means implies that they are the only ones suitable, or even that they are more suitable than those unmentioned—engines are popping up faster than anyone can keep track of them, let alone give them a thorough testing for suitability. First question on engines must be—what size? We have already noted that large engines generally provide easier flying than small, enable more liberties to be taken by the unskilled, and give more flying days in the year when smaller jobs would be grounded. But the choice is limited at present, they are often harder to start, though not always, and they hit the ground much harder when they do. If there is a background of experience of general

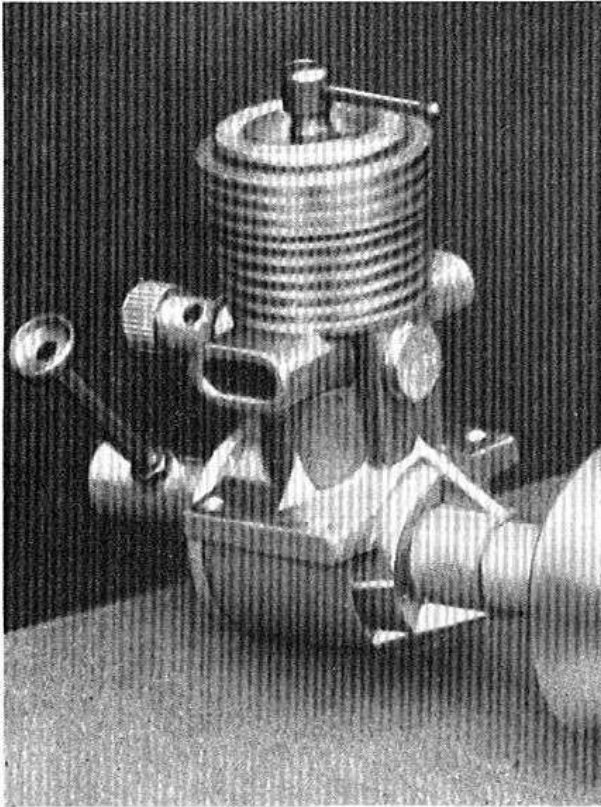

Popular Italian 5.65 Super Tigre diesel that is equally at home on a stunt or speed model. This firm have just announced a 10 c.c. diesel version that should prove interesting.

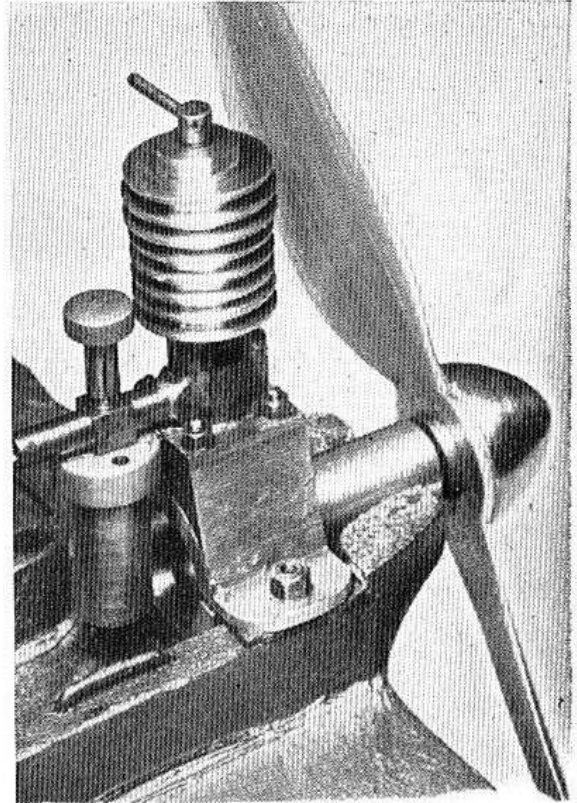

Simple mounting of an "under 1 c.c." diesel direct to the hollowed out fuselage. Metal airscrew fitted will be no trouble in this size, but frequent fill-up necessary with the tank shown.

power flying then go for one of the British "big stuff" motors, such as the Nordec; or, if some cunning exchange can be arranged, obtain an American in the same power class. We have found American "pen friends" very helpful in providing engines on a non-commercial "swop" basis—gift for a gift, though we are not quite sure just how "legal" this is. There are a number of good American engines in the country already and club members should have no real difficulty in getting one if they set their hearts on it. Do, however, remember that American manufacture does not make it good; there are some "duds" amongst them, both worn out good motors, and never-been good motors. By sticking to the better known makes it is easier to avoid such pitfalls. "Good" Americans include Arden, Dooling, Forster, Fox, Hornet, Madewell, McCoy, Ohlsson, OK, Super Cyclone—but the list could be much longer, and newcomers are legion. Of British engines it is not so necessary to speak as monthly tests appear in the *Aeromodeller*, and are systematically covering the field.

There is no need to be hypnotised into the belief that only an American job will do—in the small size field there is nothing to equal British manufactures in general, with one or two outstanding Continentals to add. Three years ago this was not the case, but to-day our native product in the diesel field can beat the world, size for size. Of present day Continental engines that can be recommended we would list Supertigre 5.65 c.c. and its smaller brother the Supertigre 3 c.c. (actual 2.8), this latter engine has recently flown a speed model at over 105 m.p.h. It comes, incidentally, from Italy. Another Italian that should appeal is the Movo 10 c.c.—the biggest standard diesel size in

commercial production that we know. Of French designs there is the Super Delmo 5 c.c. This is a powerful job, but some users have found it of over light construction to stand up to really hard knocks. Of two that we had, one took any amount of punishment, but the other was far weaker. An unusual Delmo version is the same motor linked up to another to make 10 c.c. with a single crankshaft going right through. It is spectacular, but *not* twice as good as the 5 c.c. Micron have now produced their glowplug 60 of 10 c.c., which is a masterly product, and for a high revving "American" type starts quite easily by hand. The Meteore 5 c.c. may prove in the "recommended" class, but has, as yet, insufficient case history to justify unqualified support. No other Continental, though there are quite a lot of good ones, can be classed as outstanding.

In selecting an engine the choice is now between spark ignition, glowplug, or diesel. All have their partisans. Those who have never—and there are many like this—had any experience of spark ignition, may tend to shy off from the complications of coil, condenser, and batteries. But it is not really as bad as all that. There is an excellent literature on petrol engines, and a good many years' background. A week-end spent bench running will cure any of these nervous types, particularly if a friend who knows all about it can be roped in to help. Advice here, for complete satisfaction, is to choose your helper as carefully as you

Nordec 10 c.c. engine in its glowplug form. This is the first serious rival on the home market to the wide range of "hot" American motors.

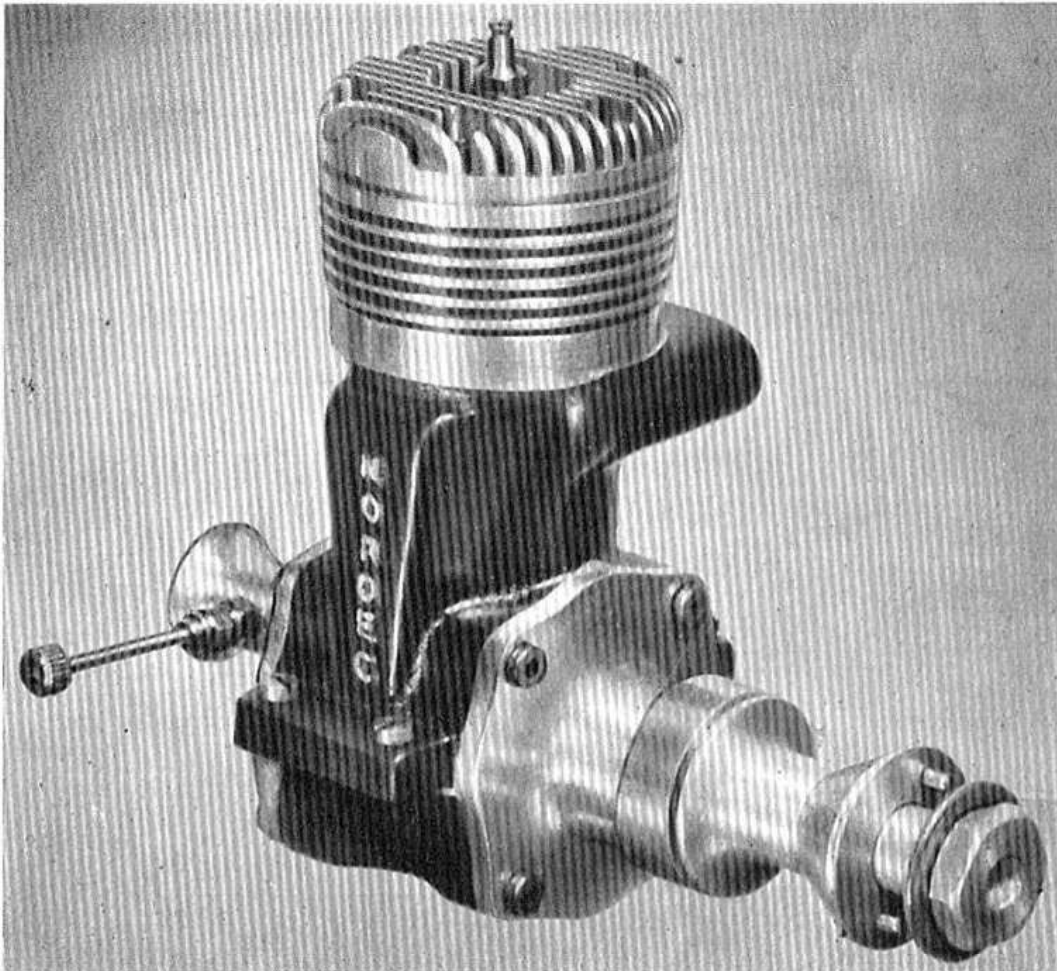

selected the engine. From a performance point of view there is something quite in a class of its own about the crackle of a "happy" spark ignition job, and its powerful response when called upon, that can never, to our mind, be quite equalled by the maid-of-all-work diesel with its constant power output. Such an engine is essential for those who intend to go in for niceties like engine control, single-handed flying, and taxi-ing in.

The new glowplug engines give a happy medium in performance, with the performance of spark ignition jobs and almost the carefree starting of the diesels, but have certain disadvantages in allegedly quick wear, and occasional trouble with the hotwire department. Whether these disadvantages are real or fancied it is too early to state definitely. We will quote from the experience of one user who sent his compressionless engine in for servicing in the belief a rebore at least was necessary, to be informed by the repairers that his glowplug required screwing down!! The quick-wear bogey had convinced him untested—it will be a long time before he is allowed to live that one down!

There remains the diesel, which will probably be the choice of the greatest number. Here an absence of etceteras may be claimed to outweigh other advantages. Nevertheless there are certain losses that must be considered. The diesel gives its power comparatively low down in the scale of revs., and though most engines can be persuaded to go well up the power curve there is a flattening off rather sooner than with a comparative spark ignition engine. We give relative power curves of the Delmo 5 c.c. and the Forster 29 (4.8 c.c.) which shows that up to 9,500 r.p.m. the diesel is better, but the petrol job then continues improving up to 13,000 r.p.m., when it is about 25% better. Such an improvement will be found in most comparative tests. But there is a nigger in this particular woodpile! It is not possible always to get this improved performance with an *airscrew*; The Forster, for example, will not thus transfer its power at over 10/11,000 r.p.m., when it is not

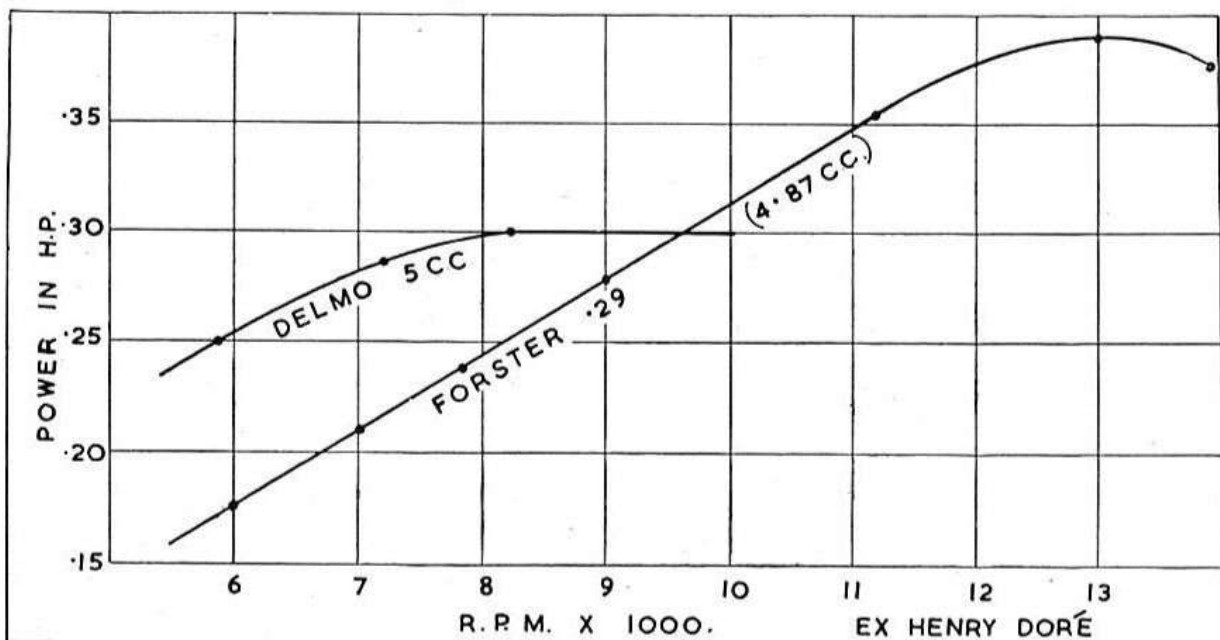



so very much better than the diesel. If it is ultimately possible to design an airscrew to absorb the potential power then the answer is obvious. Nevertheless, the Forster *has* a definite advantage of about 2,000 r.p.m. even as things stand at present.

Diesel enthusiasts may take heart, however, from the thought that spark ignition motors have been steadily developing since Maxwell Bassett first introduced the Brown Jr. to aeromodellers and may be said to be approaching its peak; the diesel, on the other hand, is a growing youngster and may well outstrip the longer-known engine. Those who like to dabble have far more chance of making headway, then, with diesels than with any other internal combustion power form.

Next consideration in choice of the most suitable engine is basic design. Comparison with early engines will show one significant change at least. They are growing down. The long piston, small bore pre-war engine has changed to a squat, square workmanlike shape with almost equal bore and stroke. In fact, many of the latest designs have greater bore than stroke. This involves, of course, far more accurate construction, as chances of power losses through piston leakages are much increased. In line with this change has come increased attention to porting, and exhaust scavenging. Exhaust ports in some engines are now so vast as almost to encircle the head, and one is led to wonder if those small pieces of metal will really hold it on! Compression ratios have increased until 6 : 1 is normal, and many engines offer much more up to Hornet 12 : 1 and Hassad  $13\frac{3}{4}$  : 1. Rotary valve admission has become usual, and most of the more successful engines feature it. These improvements in performance have not been obtained without certain disadvantages. It is virtually impossible to start a really hot motor without the aid of some form of mechanical starter. Revs. have risen to such an extent that airscrews will shatter at speed purely by their own vibratory impulses, if fractionally out of balance. To sum up these super efficient

Sidewinder mounting in one of Henry J. Nicholls' machines. Intended as a stunter, controls are easily accessible; note transparent filler and air vent to fuel tank facilitating replenishment.

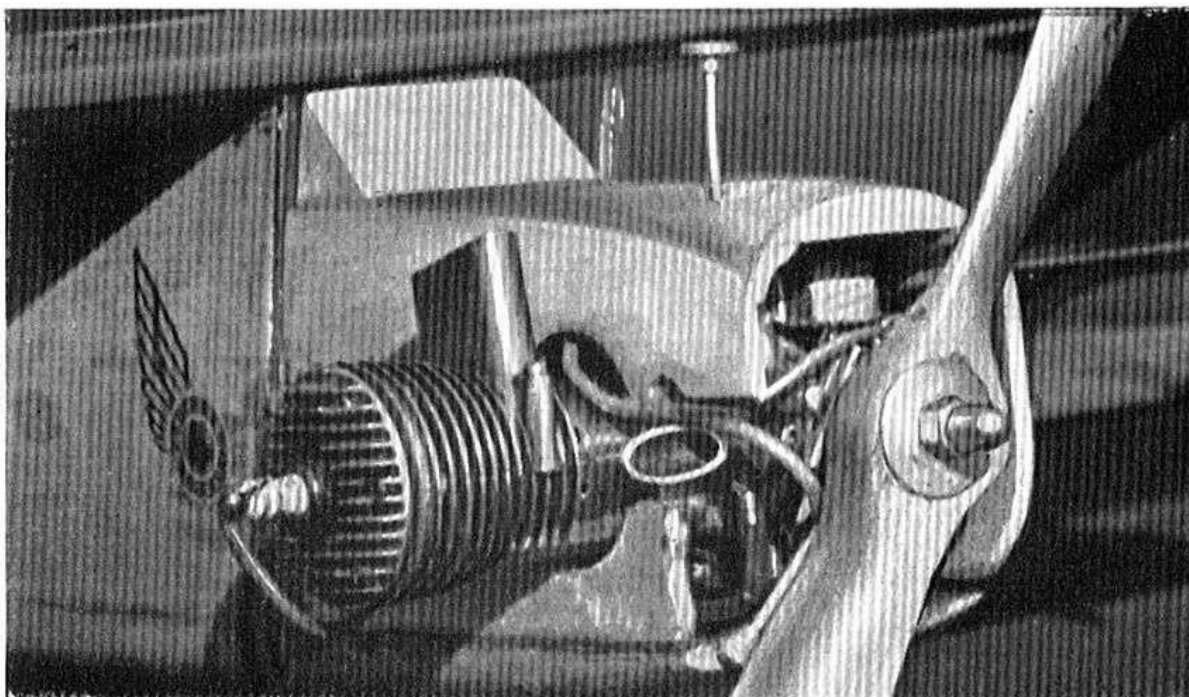

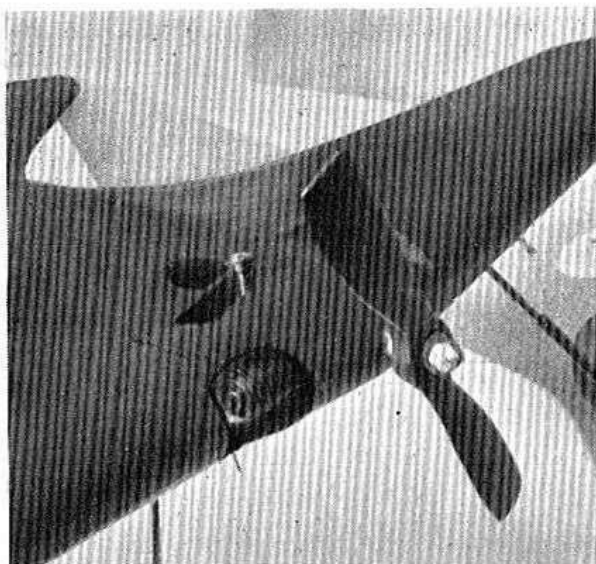

A neat effort to overcome drag by mounting engine in the thickness of the wing of this unusual model.

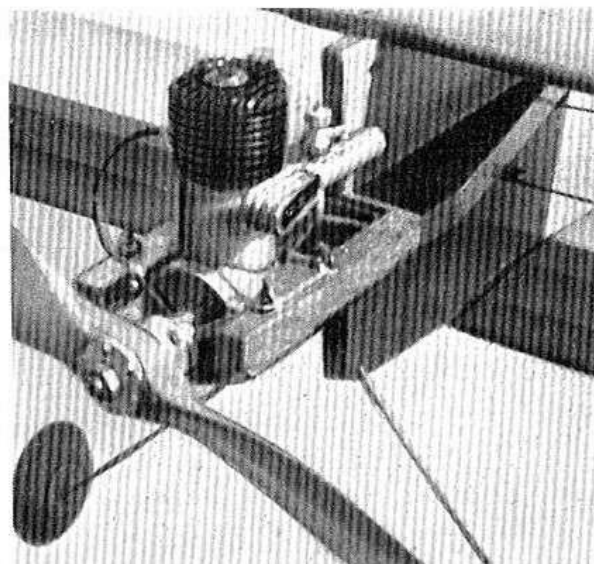

"Flatfish" fuselage with motor mount brackets for normal upright or inverted engine installation.

spark and glowplug engines we would say that they are mainly of interest to the mechanically minded with sufficient skill to operate them, and sufficient knowledge to avoid taking undue risks. They are *not* for beginners. On the other hand, the opportunity of handling such little engineering masterpieces has tended to attract a new class of aeromodeller to the ranks of control line flying, whose interest can only be beneficial to the hobby. We speak of that class of model engineer whose interests have until now been centred on such branches of model building as racing hydroplanes and cars. They bring a high degree of technical skill to the power unit side, with, to experienced aeromodellers, a woefully deficient knowledge of the airframe aspect. Their presence in clubs will, however, do much to "improve the breed," and there is no doubt that the particular skill they bring will be as welcome to their fellow clubmen as the aeronautical angle will be to the newcomers.

Diesel engines, too, are showing radical changes since their first introduction to British enthusiasts. Here, again, there is a growing down tendency; attention to porting; increased use of rotary valve admission; and a general refining of design. In common with other internal combustion classes the more expensive makes are fitting ball bearings; taking greater care in the selection of exactly suitable materials for the various parts, and making all that progress which an ever widening demand renders possible to commercial firms.

For general all round use our own suggestion to newcomers is a diesel engine of medium power, say between 2-3.5 c.c., choosing if possible an engine that offers conversion heads for occasional glowplug use. Later, they will probably feel an urge to go in for something bigger—perhaps change over entirely to petrol operation.

Some—a minority—will step down in size to the true miniature class of 1 c.c. and under. This is excellent in its way, rendering any number of scale and even indoor projects possible with a minimum expenditure of time and money.

We must not forget some mention of jet propulsion, particularly as the S.M.A.E. have now wisely limited its use entirely to control line,

and at least one British manufacturer has commenced to market an imitation of a successful American design. Frankly, the noise is terrific, the performance startling, if not to say frightening, and the application of the jet limited to speed and scale-type speed flying. Except as a sensational finale to a meeting, or an interlude for the benefit of there-to-be-thrilled spectators, we doubt its useful and permanent place in our scheme of things. But, then, we have so often had doubts like that, in common with the large majority of aeromodellers. We doubted pylon contest models, we doubted flying wings, we even doubted control line flying! and we were wrong every time! We shall certainly be in the front line of spectators when first we hear its unmistakable wee-woof-woomph starting up!

Having selected our engine, there remain several questions regarding its use. Shall it be mounted upright, inverted or sidewinder? What sort of—if any—cowling shall be put round it? Beam mounting or radial?

Except in scale or semi-scale designs the general practice seems to lie between upright mounting or sidewinder. Any model that lands without undercarriage must of necessity conform to this style. For aerobatic models a sidewinder with head facing out of the circle seems the obvious answer, as there will then be no chance of a change in the fuel feed when flying inverted, and the natural leaning out tendency of the mixture will assist operations. For all outline fuselage models the sidewinder again is obviously the right mounting. With more normal fuselages there is no particular structural difficulty in fixing the motor mounts one above the other rather than side by side. At the design stage it is necessary to remind readers that they will usually have to lay these mounts over to allow the thrust line to come over the centre line; though nothing catastrophic is likely to happen if this is neglected. With radial mounted engines the problem of where to put the mounts does not arise, and the engine can even be tilted at  $45^\circ$  between upright and sidewinder if the designer can think of a good reason for so doing. Few British engines seem to favour radial mounting, and not very many foreigners for that matter. Certain American engines will be found with both beam and radial mounting arrangements. To our mind, beam mounting is to be preferred as it enables a somewhat larger gluing area to be offered to the fuselage; we cannot recollect a beam coming unstuck, but have several times in various sized engines had the mounting plate of a radial engine come adrift. Where any form of knock-off mounting is favoured then such objections to beam mounting do not apply. The method used on some of the Frog kits for knock-off mounts is very practical though anti-rubber-band fiends will deplore it. The real answer is—it works!

Cowling of engines is a matter on which a lot must be said. First of all, from a streamlining point of view there is no particular advantage gained until speeds are nearing the three figure mark. To be more precise, its benefit exists in some degree lower down the scale, but the added frontal area of the cowl, as opposed to the engine alone cancels out the advantage. It is fair to say, then, that a cowled engine of 2 c.c. and under may look the prettier for it, but gains little or nothing on the score of streamlining.

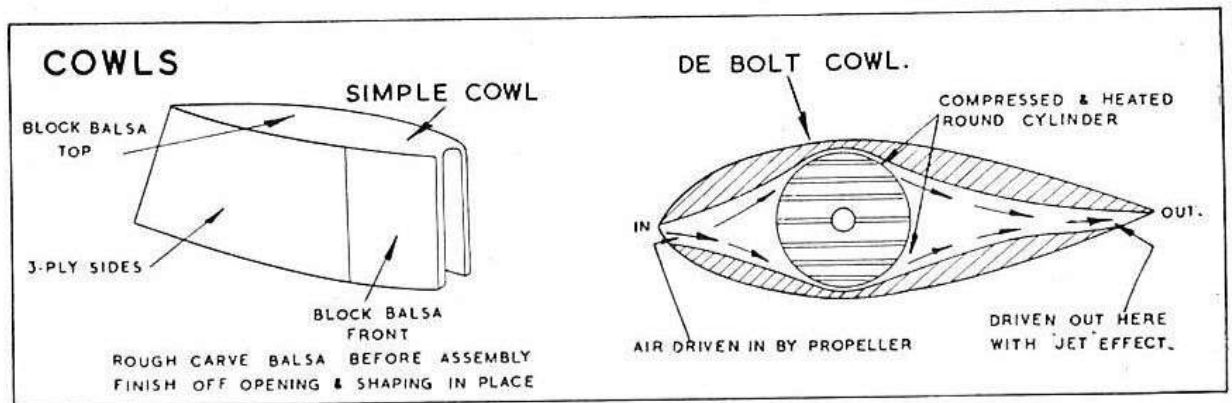

Of equal importance, or some claim greater value, is the use of the cowl to control engine temperature. Some engines, particularly the larger super-efficient Americans, perform best at a heat just below pre-ignition point. Flying without cowls they are cooled below this point and fail to give of their best. The cowl must not only have an entry for the air, but also a way out; this has sometimes been missed by designers intent on looks above everything. The size of the entry and exit will control the amount of air entering, and the manner of its exit and thus the degree of cooling obtained. The exit must be larger than the entry unless special precautions are taken, otherwise there will be a definite retarding effect like flying a drogue if all the air cannot easily escape. As the inside of the cowl is in contact with the air it must be just as well finished as the outside or drag will be increased. Its inside shape must also be given some thought. When these items have been satisfactorily checked, extra speed may often be obtained by varying the size of inlet and egress openings. As a start, inlet should be about the height of the fins and head and about a quarter inch wide, with exit slightly larger. This should suit the average engine.

That famous record breaker and designer Henry deBolt, having exhausted the usual means of going faster, spent some time on cowl design, and we cannot do better than quote him on the subject: "Good cowl design will also afford a little additional boost from the hot air that is pumped from the rear outlet. For a cowl to do this it must be properly designed (*see above*). The final cowl design is such that air enters from the side so that it may be forced in, to some extent, by the swirl of the propeller's slipstream (side must be changed if prop is rotating in the opposite direction). Then it is baffled so it flows smoothly through the engine fins only, where it picks up the required heat to cool the engine and provide the boost. After passing the fins it is condensed to its original volume and this time it comes out with the boost we are looking for. For this to work properly the curves must be smooth and there must be nothing to create back pressure such as square corners. That is deBolt's theory, and he claims it works at high speeds; we, alas, have not achieved anything in his speed class so cannot confirm or deny it.

Another point with the fitting of cowls is that they increase the amount of side area forward of the control plate and C.G., so that crabbing may ensue, and crabbing with a speed model will undo all the extra m.p.h. theoretically gained. This can be corrected by moving the

pivot point forward, but this will probably bring one control wire out of the wing where it was nicely tucked away—so the wing comes forward as well. There is now a risk of horizontal instability. Again, returning to our mentor Henry deBolt, we find he cures this problem by placing the pivot point exactly on the C.G. instead of slightly behind it, as generally recommended. This cures the trouble. But readers should be cautious of trying out this "expert" solution until they have completely mastered flying on the more normal techniques.

Faced with the problem of fitting a cowl and yet adding the least possible amount of extra frontal area, builders may like to try out the papier mâché type cowl, on much the same lines as wheels and other accessories to scale models have long been made by Rupert Moore. A shaped former is first made slightly undersize from balsa or pine, greased with candle wax or vaseline, then successive layers of paper—newspaper will do—are laid in small strips, each layer being cemented in place, until a thickness of about twelve layers has been built up. This is allowed to dry thoroughly, and may then be sanded to a smooth surface and treated for finish as wood. Any necessary holes for plug, air intake and outlet may be cut with a razor blade. The resulting cowl is quite strong, smooth and good for all but the hardest usage, and should be substantially smaller than an equivalent cowl of wood. To get extra strength, top and bottom layers could be of nun's veiling—a stiff muslin obtainable from your local drapers'. Those anxious to have the truest possible shape may elaborate this method by using a female mould pressed out of plaster of paris or its dental equivalent with the male former previously mentioned. When sticking the finished cowl to the fuselage it may be desirable to obtain a larger cementing surface by sticking square section strip balsa round the gluing edges, which when dry should be sanded round as fairings. Col. Bowden's favourite standby, plastic wood, should also be remembered in this connection.

For aerobatic flying and speed work it will soon be found that the average fuel tank provided, apart from being much too small, though recently makers have been providing larger ones in many cases, is not designed to give continuous feed when flying in abnormal attitudes, or thrown right back in the container by the forward speed of the model.

Swiss speed model by Arnold Degen. The 10 c.c. engine is completely cowled, with adequate exit for cooling airflow. The fuselage and wings are made of thin pine planking—only the cowl itself being of balsa.

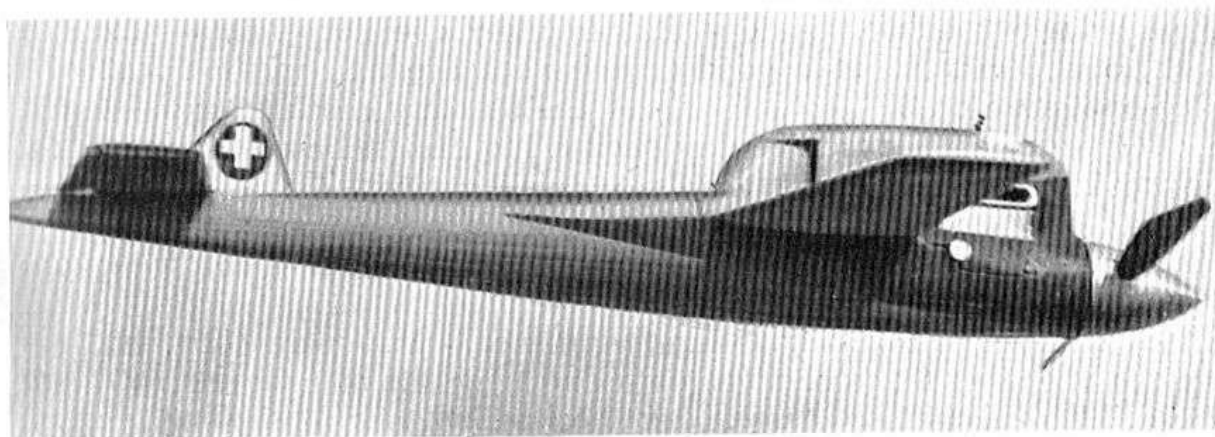

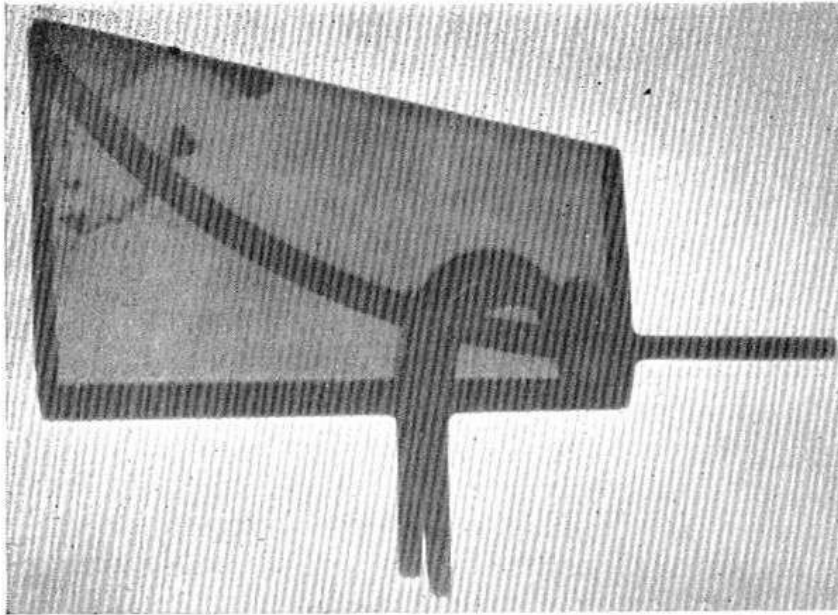

An X-ray photograph of a proprietary stunt tank, which clearly shows how the feed pipe takes fuel from the far corner where it is thrown by centrifugal force when in motion.

Simple and portable mechanical starter in use. Spinner is pressed into rubber hose which is clamped to the starter shaft with a jubilee clip. Large spring hinged switch-on flap can be seen just below the shaft.

A number of excellent commercial tanks have been devised to get over this problem. For everyday use, where normal fuel mixtures suffice, transparent tanks will appeal as they do show how the fuel level is, if they are located in sight. Generally they will not, however, stand up to "hot" mixtures and metal tanks are desirable for these. Several shapes have appeared, mainly based on a wedge principle, with internal feed pipes extending to the very back of the container. Sizes are varied and one should not be hard to find to suit the particular engine used. It may be more difficult to find one that fits the fuselage conveniently, and for this reason many more advanced flyers build up their own from shim brass. By so doing a shape that fits internal dimensions exactly may be made. Ordinary "tincan" metal can be used in place of brass shim if preferred, though there must be a greater risk of impurities in the fuel, and the action of hot fuel on the tinning.

The development of highly efficient engines of fairly high power has produced another headache for control line flyers—the problem of starting them. With one or two rare exceptions such engines when fitted with high speed tooth-pick type airscrews cannot be turned over by hand at a fast enough rate to get them popping. Moreover, if a sufficiently vigorous spin is given there is considerable risk of a backfire, when such an airscrew can be quite damaging.

Mechanical starters have therefore been devised which take all the hard work out of the operation. They are not cheap—probable cost about the same as a good engine—but are well worth making as a co-operative club effort. Basis of the starting mechanism is an old car starter motor. Even to-day such a motor can be obtained from a carbreaker's yard for a pound or two. This is connected up to an accumulator of suitable size—either 6 or 12 volt, according to starter motor obtained—with a foot-operated spring-loaded make and break switch. The whole machine is mounted on a convenient stand, preferably with wheels for ease of bringing to the flying area. When the foot switch is pressed the starter motor spins over and turns its central shaft at high speed. To this shaft is fastened a short length of rubber pipe, garden

hose, or similar stout material. To start the engine the airscrew spinner is pressed against the hose bore, and the engine thus turned over. Both hands are free owing to foot switch, and the hose has sufficient bite to grip the spinner enough to turn the engine, without any harm coming from a backfire, when the hose will just be thrust back. The spring loaded switch will prevent undue waste of accumulator which must, of course, be freshly charged for important meetings. The whole gear will go on the luggage carrier of someone's car for transport.

A simpler version of this idea is the invention of Bill Warne, who has mounted a sturdy ex-grinding wheel on a suitable stand with grinding wheel removed and the usual hose attachment for grasping the spinner. Procedure here is that owner manipulates the model while helper, brought along or conscripted on the field, turns the handle like mad. It works well and if helpers hold out, certainly saves expense of the more elaborate installation.

Fuels for internal combustion engines have come to be highly specialised, though for a very long time the model trade seemed ignorant of it in this country. Happily now blends of everyday hot and extra hot fuels can be bought at any model shop, which tends to discourage individual experiment. Most engines have a mixture that is best suited to their requirements, though this may not be the mixture recommended by the makers.

One fruitful source of enquiry that has been entirely neglected in this country, but is now engaging serious attention in America is the preparation of "climatised" fuels, that is, fuels that have been specially blended to give their best performance at the usual temperature and humidity of the district where flying is done. Thus a fuel might be suitable for a temperature of 65° and a humidity content of 60%. Research on these lines may well provide the answer and the antidote to the old problem of why a 120 m.p.h. American engine will only give a maximum of 95/100 m.p.h. when brought over here.

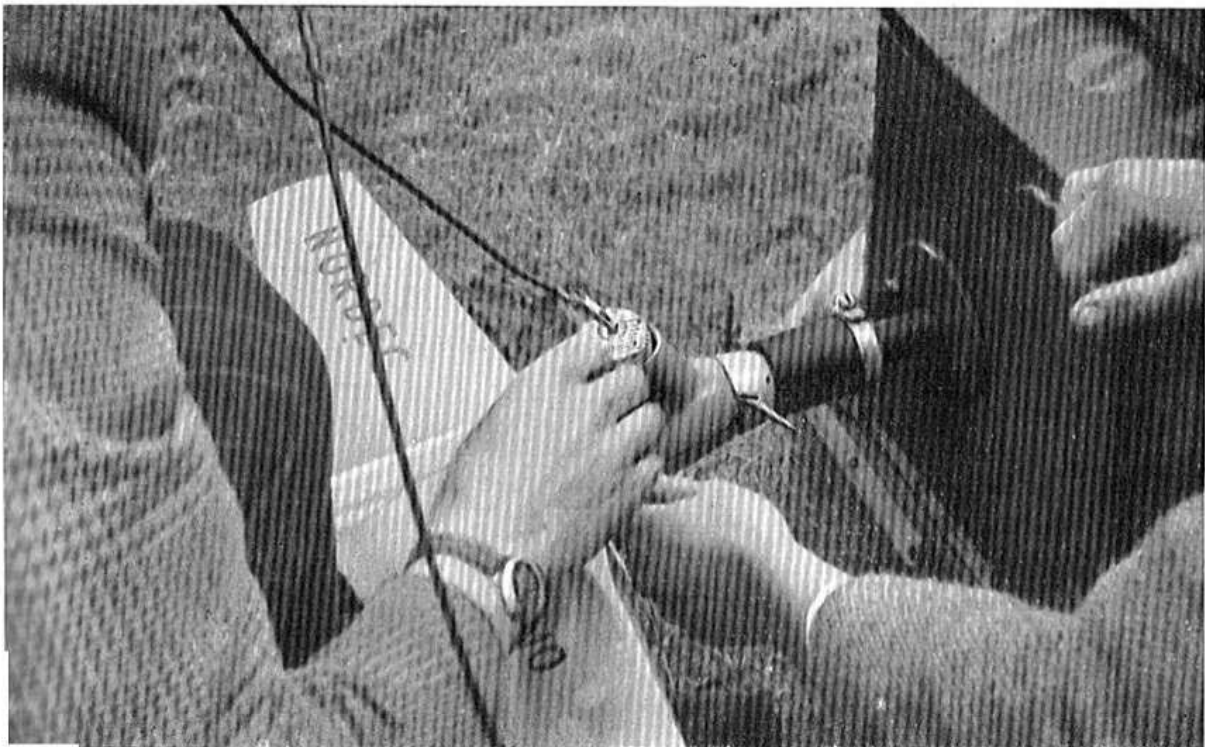

## CHAPTER TEN

# AIRSCREWS—PRACTICAL AND THEORETICAL

### PART I.—PRACTICAL ASPECTS.

WE offer no apology for putting the practical cart so firmly before the theoretical horse. This is the usual approach by modellers everywhere, to have tried a number of airscrews, and flown quite a few models, before beginning to wonder why one airscrew should be better than another. So, in our case we are sure that control line flyers will turn first to commercial products before thinking of carving their own.

Sooner or later we are certain home production will be considered, for the life of an airscrew is limited even in skilled hands. The experts, along with the novices, bring a goodly store of spares to the flying field. We well remember being present in a model shop while the proprietor sold a customer his first control line kit. He was loaded up with rubber wheels, a spinner, control handle, thread lines, and all that was necessary in the way of extras, and finally sold *one* airscrew. We suggested, when the laden customer had departed, that this was rather slipping up on the job: surely three props at least were necessary? "Oh no, indeed," replied the dealer, "that would have frightened him off for good"! The dealer was right; it would have done just that. It really is amazing how many otherwise skilled aeromodellers have never made their own power props, yet would never think of buying one for their rubber model. The bogey of hardwood carving is frightening them off. Yet, given a little practice and the right approach, hardwood power props are easier to carve than balsa ones. One well-known modeller told us recently that he could easily carve and finish half a dozen power props in an evening provided the blanks were cut out beforehand; and that sitting comfortably at his work table near the fire.

Before branching out on a carving programme, however, the newcomer is advised to try one or two commercial designs to see what he fancies. Nowadays nearly every manufacturer publishes suitable pitch and diameter figures for use with his engine as a control line power unit. The larger model shops normally carry in stock over a hundred different combinations of pitch and diameter so that it should not be hard to find the right one for your model. Once that decision is made, carefully measure up the airscrew, make templates for front and side and you can have as many duplicates as you fancy.

Beyond reminding would-be carvers that their best friend is a good coarse rasp, we do not propose to cover the physical business of propeller carving. It is adequately described in the *Aeromodeller Annual*, apart from several other standard articles and books on the subject. What may be something of a problem these days is getting the right sort of hardwood. Only small pieces are required that would



normally be thrown away by craftsmen using hardwood in bulk. It is sound policy, therefore, to make friends with some such user in your locality. Jobbing furniture repairers and undertakers are potential sources of supply; small builders and house decorators use wood, too, and will be willing to hand over offcuts for a copper or so, or even give them away. The lazy, and farseeing, man will not leave it at that, but pursue the friendship still further, for such workers have power tools, including a bandsaw, and can be persuaded to cut out a few blanks to a favourite shape. Possible woods for use are beech, birch, ash, spruce, walnut, and mahogany, though other less used woods such as pear and the Australian timbers can be used as well.

Fainthearts may still feel disinclined to embark on home prop production, but there is still a way that they, too, can save money on the prop side. In nearly every prang one blade only will be damaged. If all the props are the same make, pitch and diameter, a good one can be made from every two damaged ones, by halving the boss and joining them together. Pressure of the locking nut on the crankshaft will hold them securely in place. Again, there is no need to discard an airscrew that has lost only an inch at the tip, for a new tip can be simply mortised in position, made either from a salvaged tip, or carved anew from any scrap of wood suitable. Care should be taken to start the engine on the sounder blade and it will fly the model as well as ever a new one did.

We have also recently tried a new metal airscrew marketed for the smaller engines. Such an airscrew is not permitted in contest flying, but is a very practical moneysaver for training flights. It is just as well to start up with a gloved hand, but, contrary to our expectation, even quite a hard slap did not do the damage we had expected. They should not be used, however, on larger engines of 5 c.c. and upwards. Using a metal-bladed airscrew we have dived into concrete, wrapping the blades round the nose like banana skins, but have straightened them out and flown again. As a rough guide the usual blade will take at least six or seven such bashings before breaking off in the straightening process.

Proprietary spinners in spun aluminium which do much to enhance the appearance of any model. All sizes are available and, unlike airscrews, they can be used again and again.

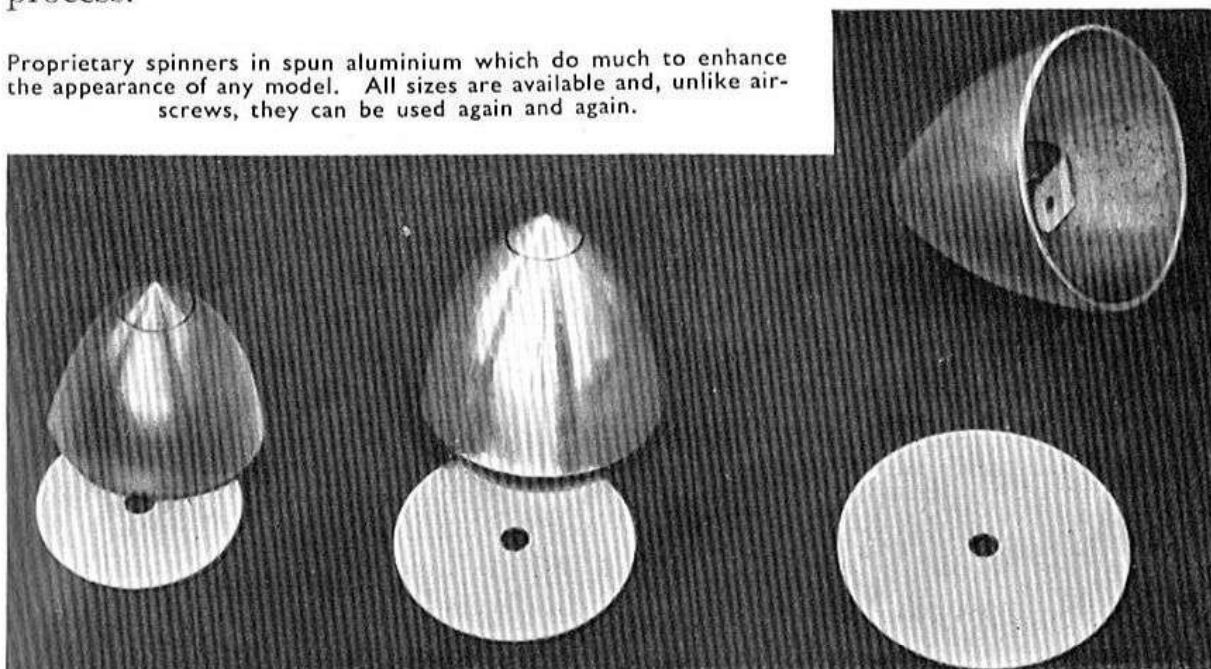

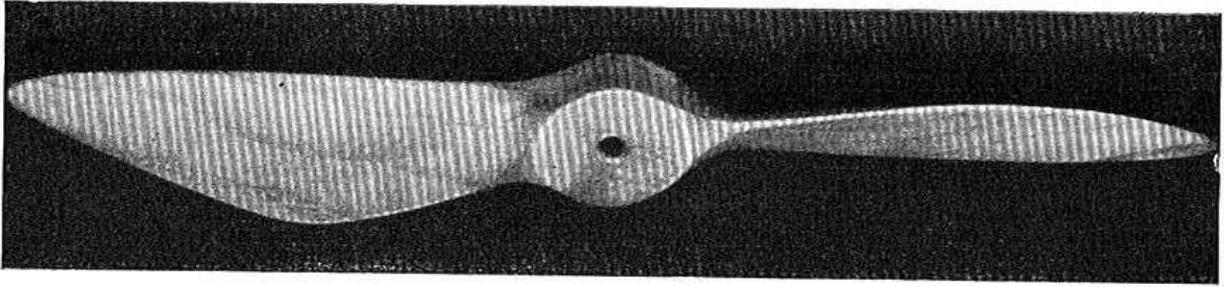

Typical proprietary aircrew (Hi-Thrust) designed for control line use, with straight leading edge and boldly curved trailing edge, coming to a sharp point at the tip.

We noticed several of our Continental visitors had salvaged single blades from their airscrews and balanced them up for use as single-bladers, with a wire arm and a lead balance weight. This, too, could be followed, though there will be some loss of power if fitted to an engine normally flown on twice the blade area. They can be stepped down to a smaller engine, pre-supposing the flyer has more than one.

A welcome sign amongst control line models has been the growing popularity of the spinner. A large variety of shapes and sizes and fitting devices have appeared on the market, made of light alloy or hardened rubber. They are little trouble to fit, and besides improving the appearance of the model, reduce drag quite considerably. On speed machines they are virtually a necessity. In any event the airscrew round the hub does no useful work, and performance may well be improved by streamlining this part, extending up to a fifth of the airscrew diameter.

## PART II.—THEORETICAL ASPECT.

We are indebted to P. R. Payne for much of the theoretical aspects in this section, and whilst by no means claiming that his views are necessarily the only ones, would point out that, carefully followed, his style of aircrew gives excellent results, if, in the eyes of many, a rather ugly duckling, with its parallel blades and square tips.

The aircrew can make or mar the performance of any model aircraft, and nowhere more so than with control line models. In free flight models slow speed flying is usual, and the normal inefficiency of standard designs has a relatively small effect. With control line models, all but the very slowest are flying faster than the fastest free flight power model. A badly designed prop here can lower flying speed by as much as 20 m.p.h., or more, with speed models, because of its low practical efficiency.

Until fairly recently the customary British practice was to use helical, or constant pitch airscrews. The pitch on such airscrews is constant all along the blade, blade angle being varied from hub to tip in such a way that all the blade elements move forward the same distance in one revolution. Thus, we speak of ten-inch pitch, meaning that the whole aircrew would move forward ten inches if it were rotated once in some solid medium. Most airscrews obtainable to-day are of this type, though happily some of the more progressive makers are now offering a better design of which we shall speak. It is, therefore, somewhat surprising to note that a constant pitch is by no means the most efficient for model use!

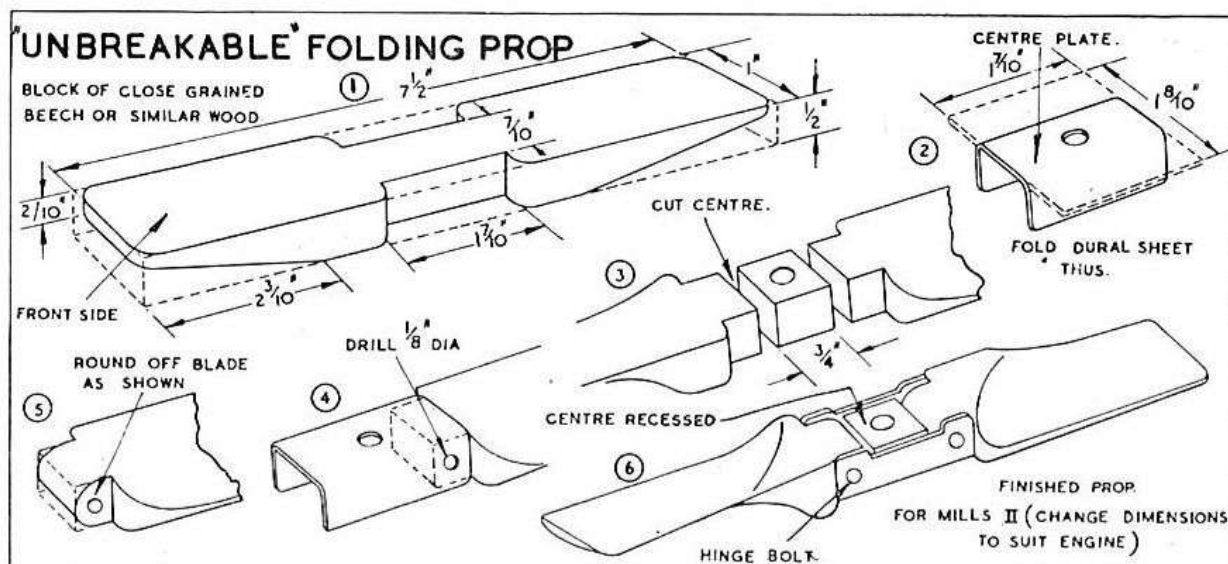

This fact was first publicised by D. A. Russell in his *Design and Construction of Flying Model Aircraft*, as a result of an exhaustive series of experiments. He maintained that the tip-pitch should be 10% greater than that at a position seven-tenths of the radius out from the hub. Owing to the war, and consequent neglect of power modelling, the initial interest in this matter cooled and other events took pride of place. It was not until 1943 that L.S.A.R.A. Director N. K. Walker approached the subject, and, in the November, 1943, *Aeromodeller* covered the theoretical ground in some detail. Unfortunately for the general aeromodeller his article was couched in highly technical terms and thus made no particular impression. It was, however, responsible for one notable contribution—it gave the new form of airscrew a name—non-helical pitch airscrew—which it has retained.

It was left to P. R. Payne, therefore, to make use of this theory and apply it to practical use, producing a series of airscrews that show a 50% increase in efficiency over the more usual constant pitch type. As noted above a number of manufacturers are now availing themselves of this knowledge and producing commercial props embodying the non-helical pitch principle.

Apart from his researches in blade angle theory Payne has produced his own typical parallel chord blade shape. This is ugly in appearance, but, at low speeds anyway, such a shape is more efficient.

Experimental Payne type airscrew fitted to a small diesel. Manufacturers have been very co-operative in providing additional facilities for control line airscrew tests for the benefit of all concerned.

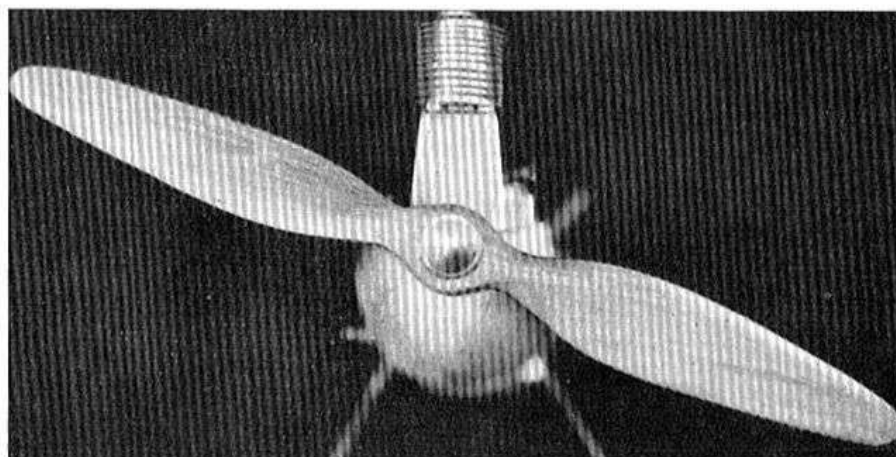

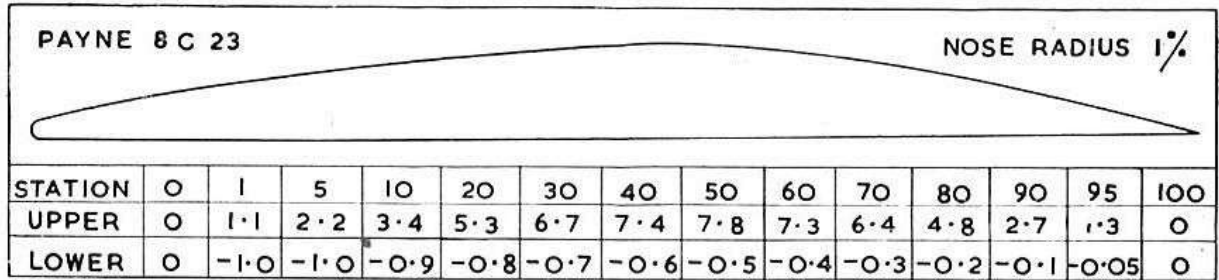

Its advantages at high speeds are more problematical, and no claims can be made without considerable additional research.

Not content with the standard Clark-Y type of blade section, Payne has produced his own turbulent flow section, which gives considerably improved results. Thickness should remain constant from the tip down to a point four-tenths of the radius from the hub, when it may be thickened and faired into the hub. Extreme accuracy in carving is necessary to secure the maximum benefit from the design.

Those who hope to capture and hold speed records against a growing challenge will find airscrew design a necessary part of their work. Unlike the stunt or general flyer who will be satisfied to match engine and airscrew without particularly considering the airframe, speed models should be designed as a complete unit. Their first thoughts will tend towards the American "tooth pick" type of prop, with its thin blades and reduced frontal area. These can increase revs. to almost fantastic heights, though whether they are the most efficient type it is possible to design is a debatable point. To assist starting and running such blades have frequently a loaded hub to produce sufficient flywheel effect. This can be most conveniently concealed in the inevitable spinner. A word of warning is necessary when using such thin props. At high revs they reach a "fragmentation" point and shatter spontaneously; similarly, if out of balance they can set up this shattering effect at lower speeds. It is inadvisable therefore to linger near them in "the line of fire" longer than needful, and to be wary of following round a dolly until under way, as we have seen done, apparently without knowledge of unpleasant possibilities.

Our Italian friends have taken to an almost paddle like airscrew for some speed models, and have even added a lump of lead to *one* blade, presumably for flywheel effect. Recent designs have, however, featured the typical toothpick, so we must assume the future of paddle blades is limited.

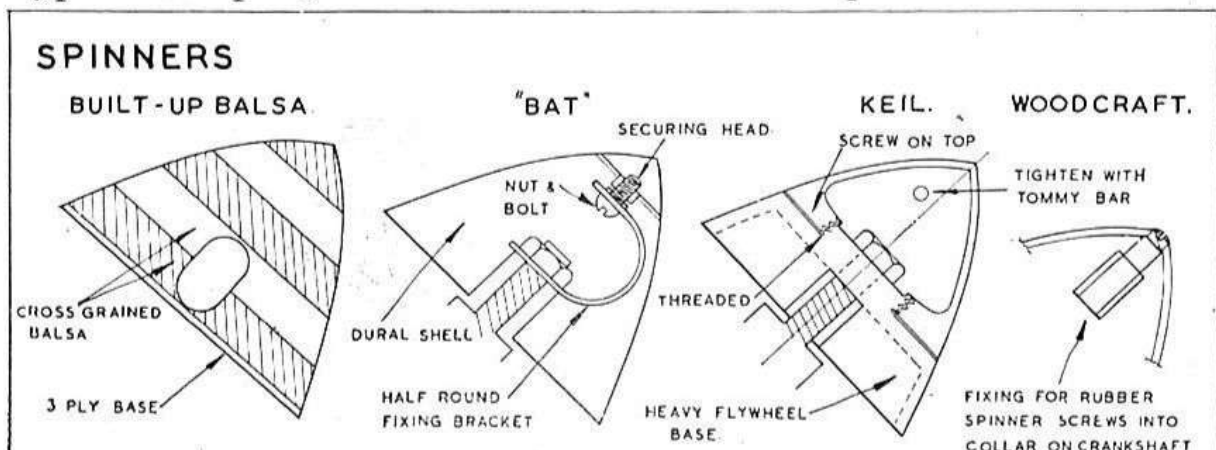

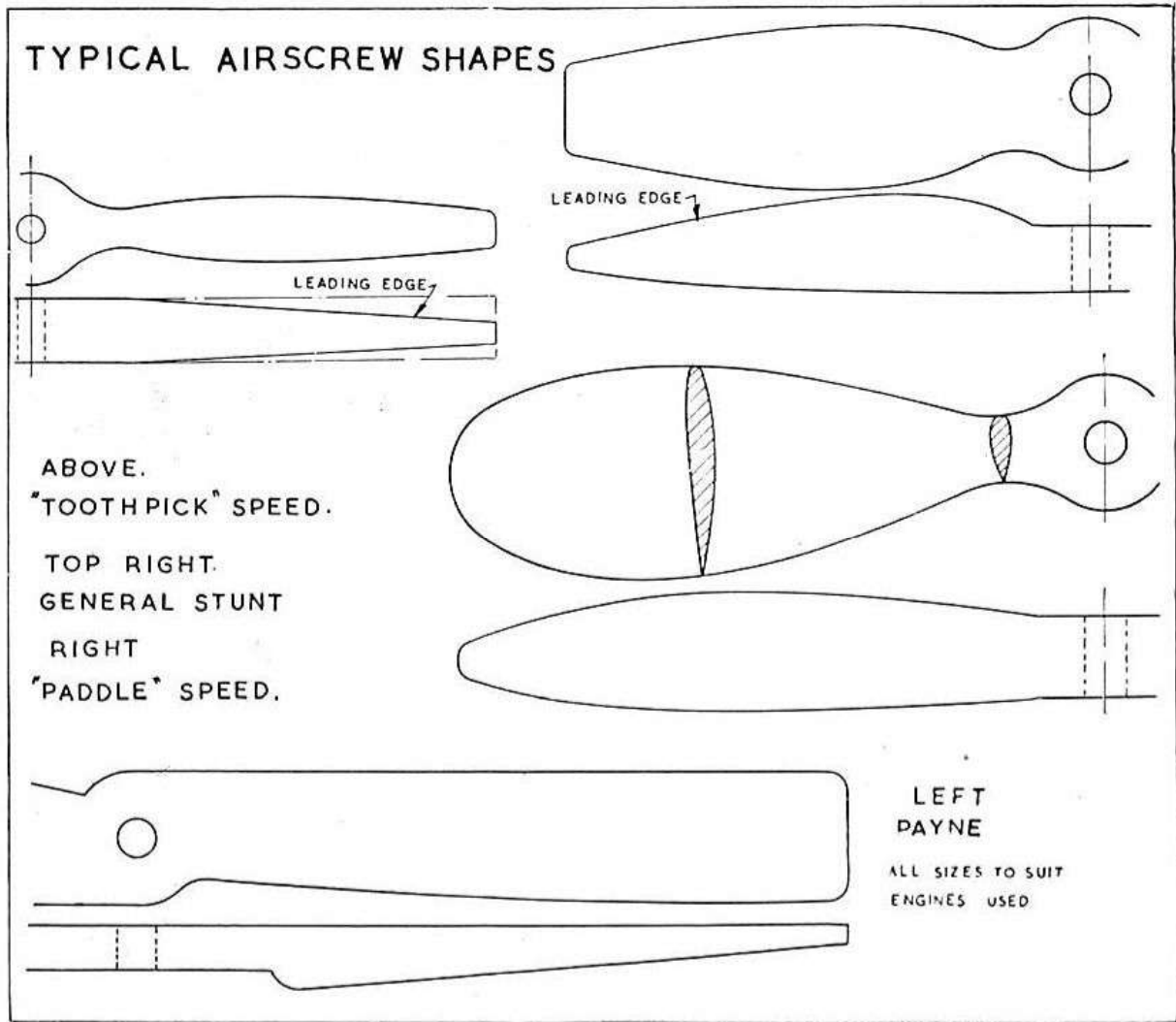

Experimental biplane design with Payne airscrew specially designed for Delmo 5 c.c. In spite of its ugly lines it is extremely efficient.

Italian "paddle" type airscrew in an intermediate speed machine. This airscrew has lead inserted in one blade for flywheel effect.

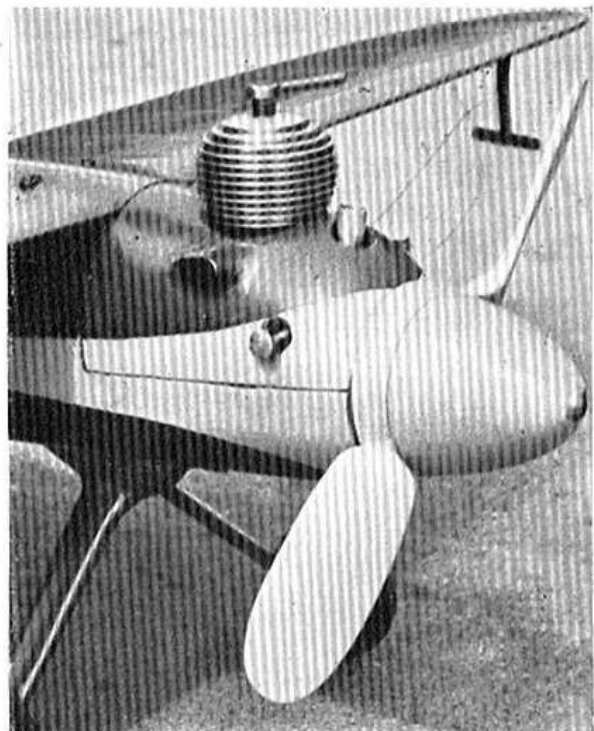
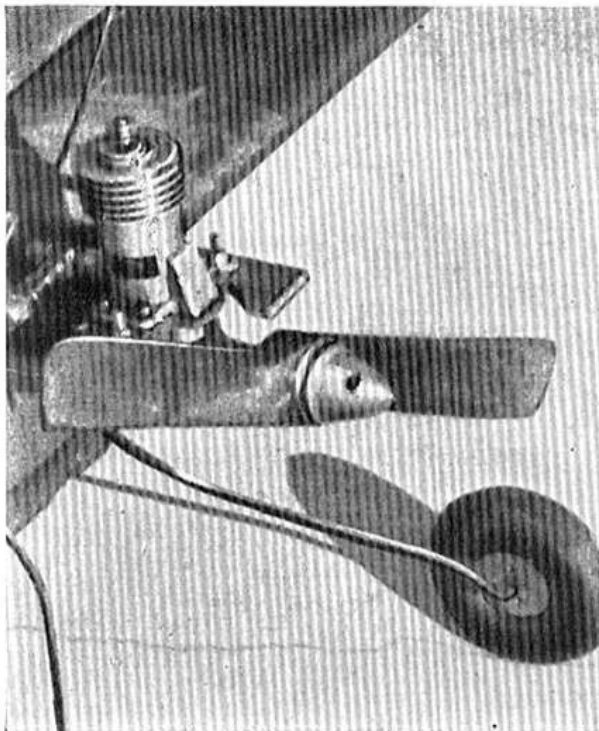

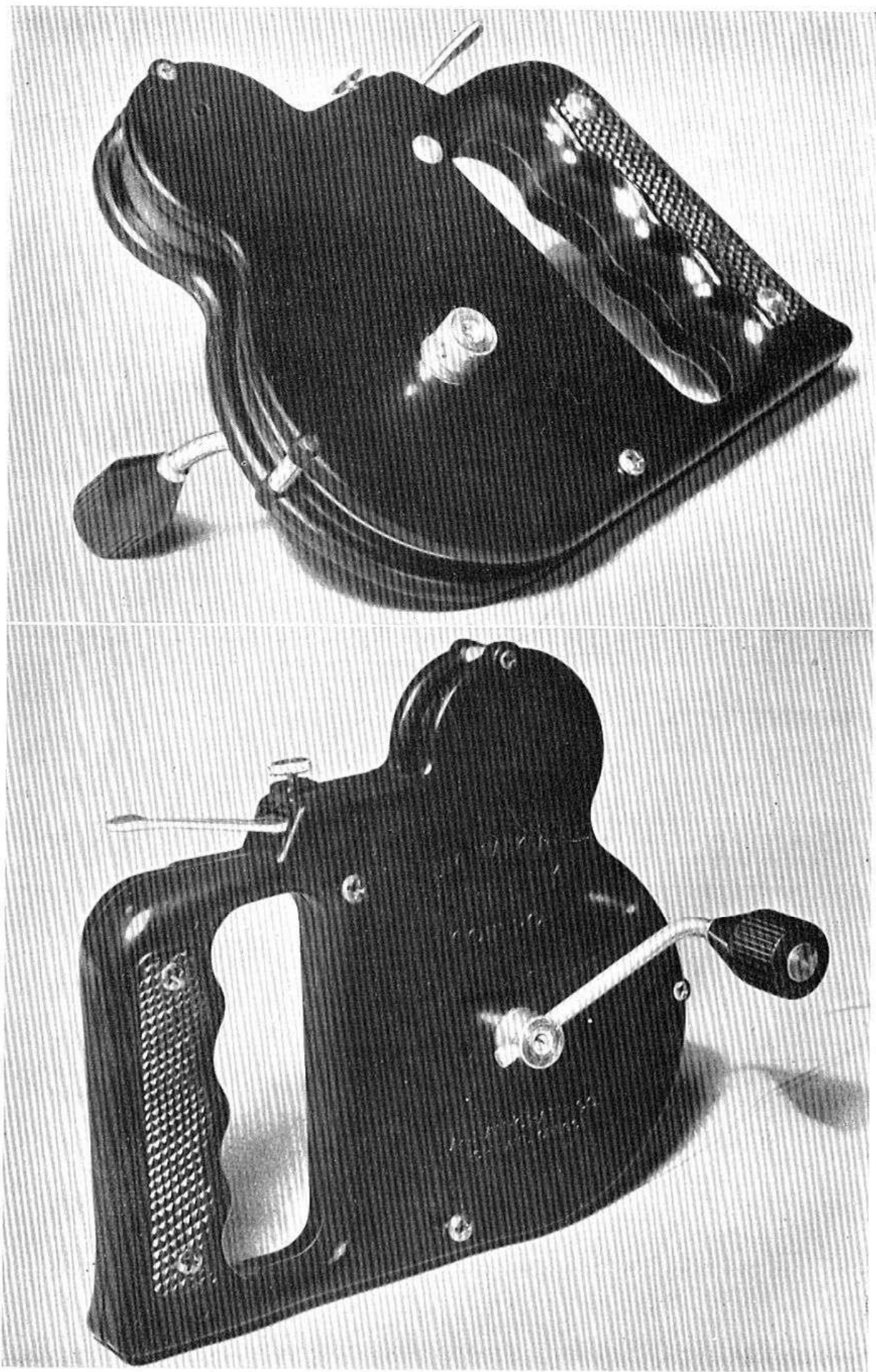

Two views of the justly famous Jim Walker U-Reely handle—a commercial version of which will be welcome in this country.

## CHAPTER ELEVEN

### CONTROL LINES, REELS AND HANDLES

WHATEVER form of control line flying is taken up, it is certain that a large part of its continuing success will depend on a proper selection of lines, carrying reel and handle. Unlike fishing, where sometimes the best catch falls to a lad with a bent pin hook and a piece of string, attention to tackle is desirable from the very beginning. We have seen models flying on what looked like furry parcel string, with copious knots along its length, but the model at the end usually looked even worse, if that were possible.

First comes the question of thread lines or wire? For the man who is often going to be without an intelligent helper, for the younger beginner, and the casual interest merchant, we would suggest thread for a start. It will stand more abuse than wire, can be unravelled more easily, and requires less maintenance. There is no need to be high-class in buying it. We tried some of the very best quality silk fishing line and found it absolutely useless. The stuff stretched abominably, which would have been just the thing with a large carp at the other end, but not so clever with a model, for the controls refused to answer without a prodigious tug. With ordinary carpet thread, or the cheaper types of linen thread at 6d. to 8d. per hank, we found an immediate positive response, and a substantial cash saving on the better grade. Thread has more drag than wire, and the line will bow quite alarmingly sometimes, giving the impression of considerably whipping by the flyer, but it does its job with the smaller lighter models within its breaking strain. Then, when flying is over, it can be simply wound round the control handle without a care in the world. There is not much that need be said on its maintenance, beyond keeping it as free of fuel, oil, grease and other rotting agents as possible, and seeing that knots are firm. When it begins to fray and look perished, throw it away and get some more.

All serious flying involves the use of steel wire, of an appropriate thickness to suit the model to be flown. Drag and dead weight varies considerably between the thinnest and the thickest. If the frontal area is bulked it will be appreciated that even a thin line represents the equivalent area of a penny flying round midway between model and pilot, and thick line something about the size of a small cocoa tin lid! Do not, therefore, play unduly safe with a hawserlike wire when it is not necessary.

Wire is sold in reels of approximately 200 feet, in both plated and unplated qualities. The plated sort is better as it is more rust resistant,

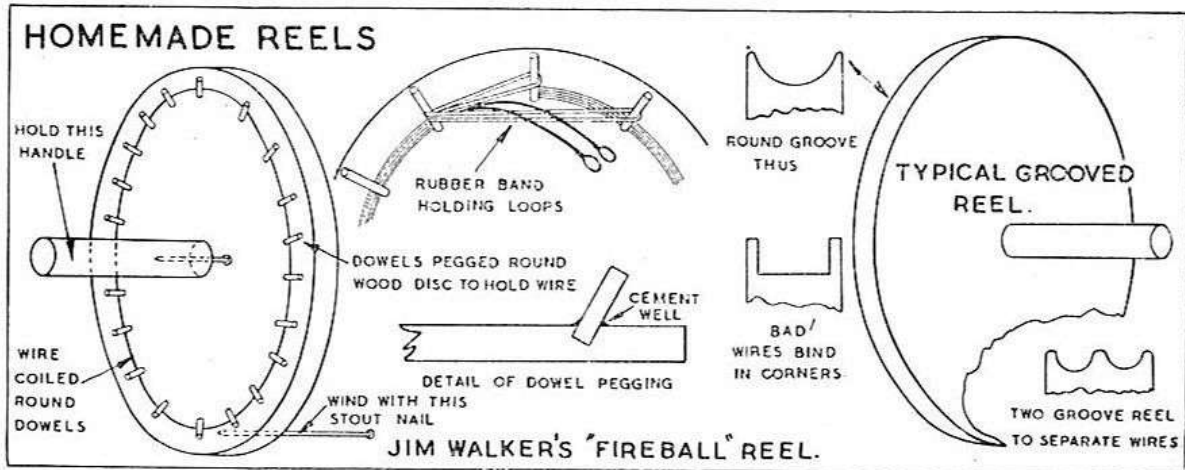

but the plain type is just as strong though it must be inspected more carefully for defects. The tyro often gets in a tangle unwinding his first reel, and may, through ignorance, spoil the coil before having a flight. Before touching any of the wraps procure a helper and some temporary holder, such as a thick cardboard tube, a broom handle or similar, having length though not necessarily thickness. The coil may then have its wraps unloosened. The individual turns will then spring open, half way up the broom handle, but this does not matter as they cannot tangle about themselves. An end is then taken and firmly wound on to the carrying reel, which may be an empty cocoa tin; or a dried milk tin, large size, makes a good carrier for a start. Once firmly wound on, a small loop is made in the free end hooked over a conveniently placed nail, and the length of the line paced out. For accuracy, such as when making up lines for speed work, this length should have been carefully measured and marked previous to this. Cut the line with pliers (not scissors!) leaving ample to make a further loop, which when made should be hooked over another nail. In the open this may present difficulties, but a screwdriver stuck point down in the ground will make an effective substitute. Repeat the process for the other line, and the job is done. To keep the line tight on the improvised tincan reel, a short length of adhesive plaster tape is excellent. Lines should on no account be allowed to lie loose and sloppy on the reel.

Although a number of quite expert flyers have been content with such a reel, it is not the best by any means. Better by far to make up Jim Walker's own original reel, first produced in 1940 and still used by experts. Here a circular piece of thick three-ply or planking is cut out about 10 in. in diameter. A circle is marked with a compass one inch in (8 in. diameter) and on this line at intervals of about an inch a series of  $\frac{1}{4}$ -in. holes are drilled at an angle inclined outwards at about  $60^\circ$ . Short lengths of dowel are driven into these holes with a dab of cement. A short length of broom handle is fixed in the centre for a hand grip, and another piece of dowelling or a nail driven in the other side towards the edge to make a winding grip. Just inside the circle of dowels two small nails or screws are driven in to take the line loops, and the line is then wound round the dowels. A small elastic band goes through the loops at the other end and is hooked over the most convenient dowel. Nothing could be simpler or more practical.



Some fliers like to keep their two lines separate on the reel, and for them we suggest a double grooved reel, using inset screws to take the loops, and again hooking the loose ends up with an elastic band to a conveniently placed nail. There are any number of elaborations to these ideas that are limited only by the materials and resourcefulness of the maker.

It should be emphasised that it is better to detach lines altogether from the handle when not in use, though many do not follow this advice. If they do not propose to do this, then by all means let the handle dangle at one end; but do not say you were not warned when kinks quickly develop, and a snapped line spoils your latest brain child!

In the early days of control line flying it seemed that any old piece of wood that could be held in the hand was good enough for a handle. Now the better kits contain a suitable piece of wood with instructions for shaping the handle. We have found the best home-made handle is one shaped like a  $f$  sign, curved at the top, and with a projection like the base of the sign. This is always held  $f$ -up, with the up-line attached at the top. Thus, however hastily it is grabbed for a flight there can be no risk of picking it up upside down as it will not feel right. This is best made of a scrap of heavy  $5/8$ th or thicker ply for strength and to give some feeling of weight in the hand. We have found thin lightweight handles give little sense of control, though we agree this is a personal feeling, and may not apply to everybody. There are any number of alternative shapes, all with their following. Where a symmetrical shape is used mark top with a dash of paint.

Lines are attached to the handle via a short securing hook, which, as noted for control leads in the appropriate section, should be so designed as to avoid twisting the control lines. A paper-clip style of fixing made from steel wire of 16 or 18 s.w.g. is as good as anything. For speed flying and advanced control work it is a safety precaution to have about two feet of line at the handle end made of thicker multi-stranded wire. Then, if by some mischance the wire becomes twisted round the hand, there will be no harm done. The line fixing loops are then attached to the end of this safety line.

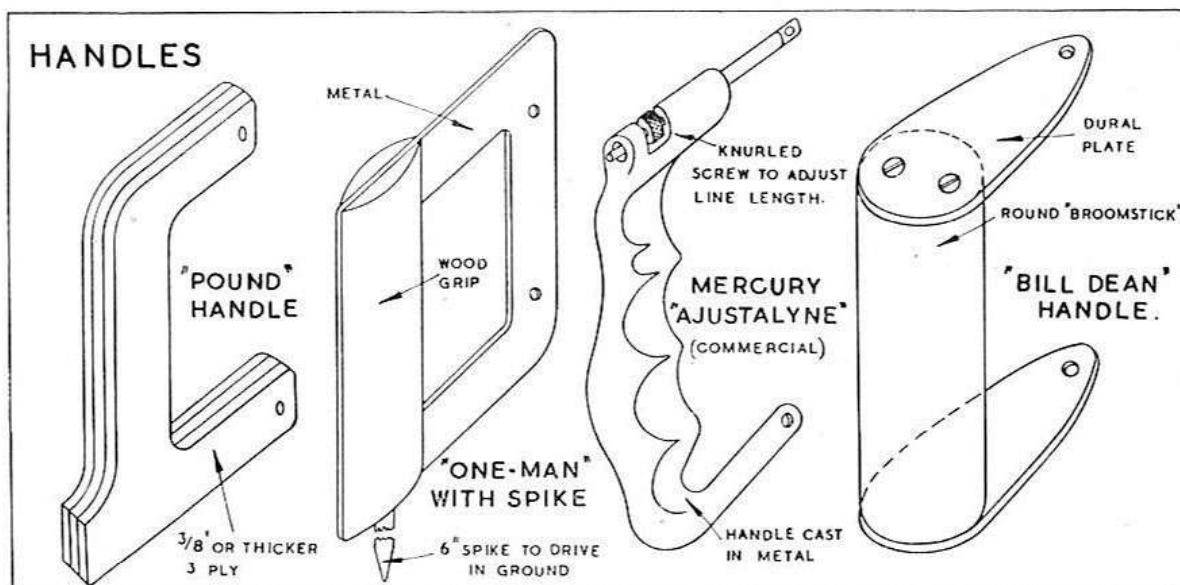

For those who desire the strength of wire lines with the non-kink virtues of thread the trade have conveniently catered with multi-stranded lines. These are naturally thicker, and with more drag, than single lines, but, if not entirely kink-proof, are at any rate kink resisting. For small models, however, their weight and drag is such as to interfere to a noticeable extent with flying, and even make models impossible to fly.

As usual, the trade have rallied round with a number of medium priced handles which will solve the problem for those who require a ready made job. Of these we have found the Mercury Adjustalynne the best, as it is conveniently grooved for the fingers, and has top and bottom different to give the advantages of our own  $\text{f}$ -handle. In addition there is a short length of screwed rod, adjustable by a knurled ring to balance any slight inequalities of line length. It is heavier than the usual wooden handle and gives a good feeling of control. We understand that a British version of the famous Jim Walker U-Reely line, combining reel and handle, will soon be available. Such an accessory renders possible stunts like unassisted take-off, variation of line length in flight, and, with the electric version, engine control of a spark ignition motor. So far we have not even seen enamelled control line wire in this country, so the prospect of such control may still be distant.

We have made up a variety of the U-Reely line in wood, using a wheel from a pulley-launch rig which may be of interest for those wishing to try out this style of handle-reel before spending money on one.

Before flying, the pilot should get into the habit of regular line drill. Once laid out the lines should be passed through the hands slowly and each length examined for rust spots, kinks, or other weaknesses. Then with helper holding the model, the handles should be pulled firmly with a pressure of up to forty pounds according to the size of model. Joints should be carefully scrutinised at the same time, as rust at soldered wraps is very prevalent, owing to inefficient cleaning of acid fluxes.

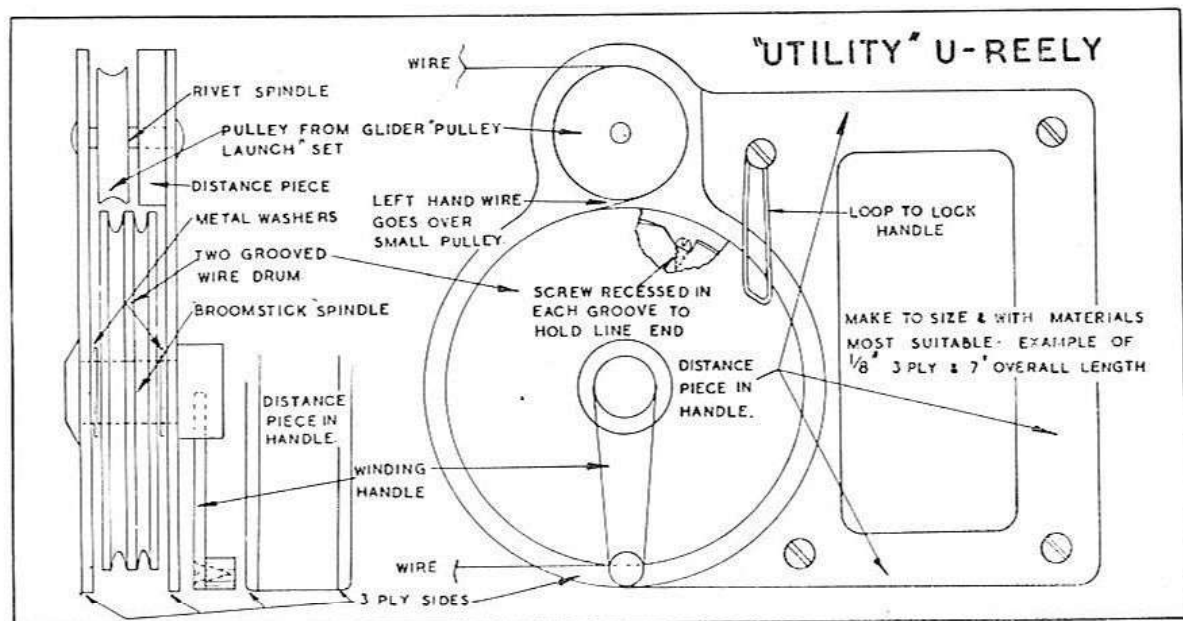

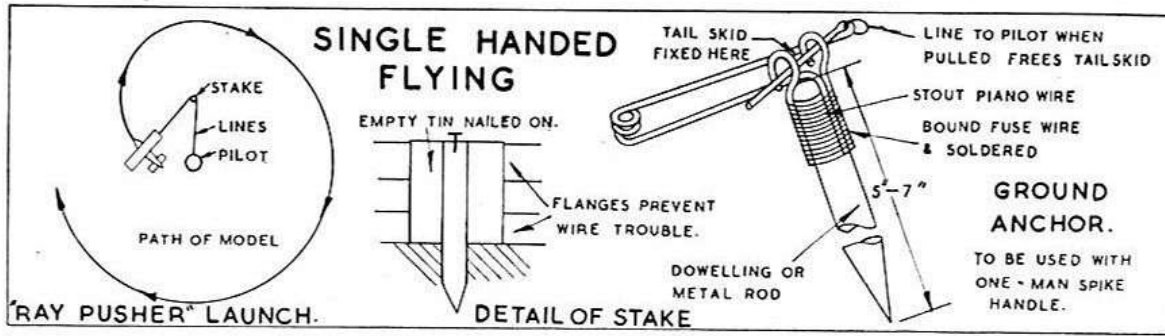

For this reason some flyers will have nothing to do with soldered wraps, but rely entirely on the strength of the twisted wire. If properly done it should be enough; this is another of those controversial points where the individual will choose his own side.

Those who cannot always secure the services of a willing—or even unwilling—helper will find F. B. Thomas's spiked control handle, and skid-release of practical value. Here the handle is stuck in the ground at the centre of circle, the lone flyer starts up the engine, having previously locked the skid in place on the holding device. He then proceeds to the centre of the circle, grasps the handle and pulls out the release pin with a thread third line, allowing the model to circle free. In reasonable weather conditions this works very well, and certainly permits private training. Very powerful models with large engines will tend to vibrate free or noseover on release so that the method should be restricted to smaller sizes unless specially designed for this type of release. An alternative one-man flight that we favour is the idea of Ray Rusher, a well-known American gadgeteer. This also requires reasonably calm weather, but enables a spectacular release, without any movement from the centre of the circle by the pilot. The principle of this is to double the lines back round a peg, reducing the initial take-off circle; the model gains speed from the pilot's hands, turns about the pivot of the peg, and is then running in its true circle, and takes off normally. An extensible line is an advantage here, but it can be accomplished without it. For initial experiments thread lines should be used in case of tangles and, of course, an old and not too treasured model.

We have left the subject of multi-line controls until the end as there seems a marked indifference towards them as yet. These are used to actuate either engine control, via the ignition switch or a simple on-off engine shut off, bomb dropping, undercarriage retraction, or similar stunts. The addition of a third loose line to the two flying controls will be found rather an embarrassment to beginners, and will get in the way of stunters, but for those reasonably skilled who desire to work accessories on the model it is almost essential. A delayed action timer type of accessory control has been suggested, but is not very sound, as things being what they are, the release invariably comes at just the wrong moment—such as undercarriage retraction in advance of schedule, with model still grounded! The American method of control through enamelled control wires carrying current from a substantial battery in the pocket of the flyer has many advantages, but must await stocks of suitable wire.

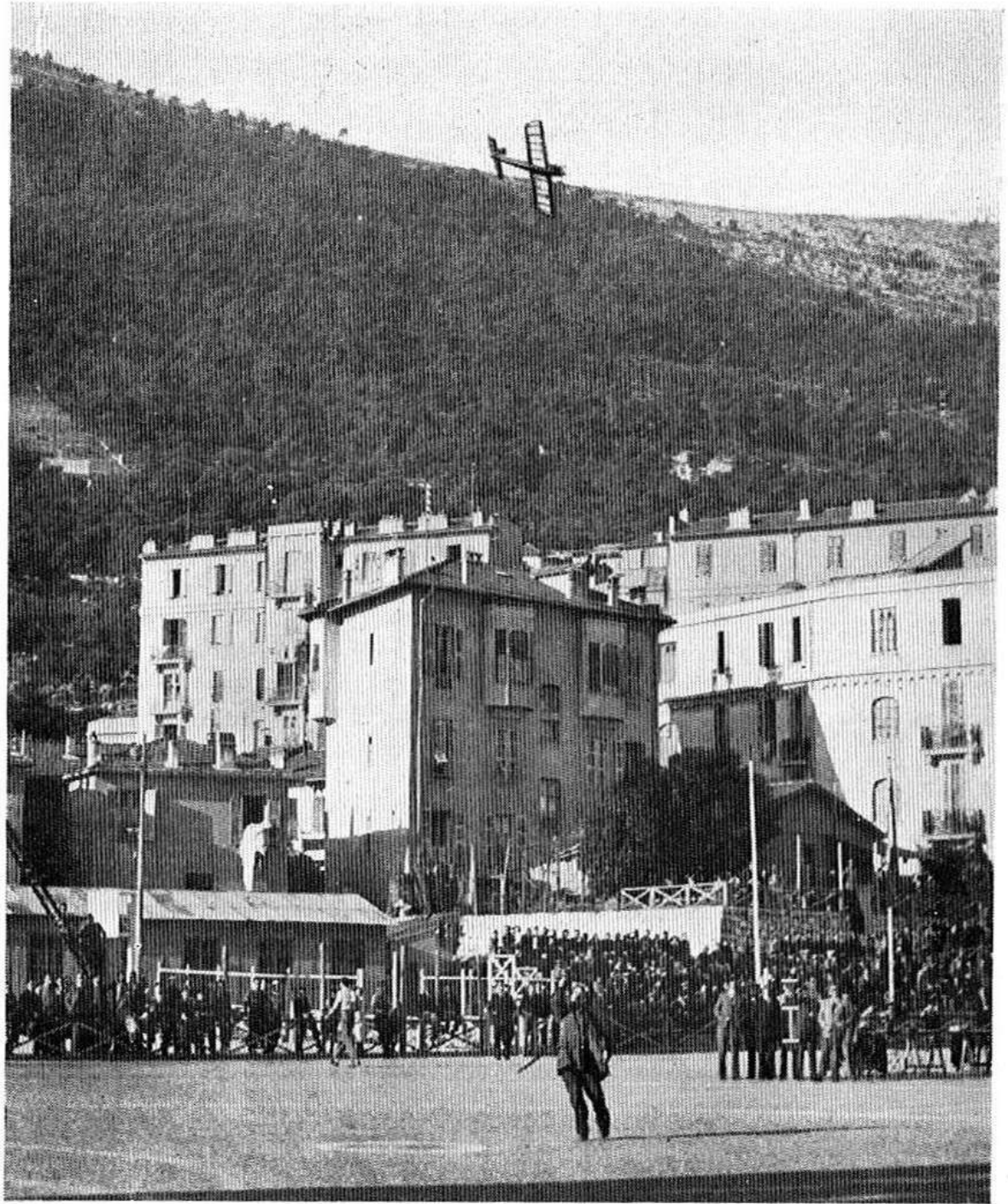

Spectator control is most important if completely carefree flying is desired. This shot of a competitor performing a wingover comes from Monaco where the club makes use of a local football and sports ground for their meetings. Keen club secretaries should be able to make similar arrangements for their members by a little judicious "lobbying" of Councillors and other V.I.P.s.

## CHAPTER TWELVE

### ELEMENTARY FLYING

CLUB members will have a great advantage over "lone hands" in that their control line adventures can be mutually shared and some mistakes avoided, even if none of them has ever flown before. This may sound strange, but is perfectly true. By watching one or two others do the wrong thing there is a chance you may be able to avoid it when your turn comes. But don't rely too much on this. We learned the hard way without a control-liner amongst us, and listened very patiently to the advice of one kindly soul who was determined to be last in the air. He was: and made all the mistakes we had all made! It is a strange thing that in our own little group of seven or eight learners everyone of us made the same basic mistakes in roughly the same order—even though we all knew what we were trying to avoid, and had any amount of encouragement from outside the circle. Of course, the ideal is to get elementary training from someone who already flies reasonably well, although here there is the risk that the instructor will tend to give plenty of demonstrations and not too much of the actual flying instruction.

Happily it is not necessary for a model to be particularly well built for it to fly quite successfully; but it is necessary that certain parts at least are strongly built. Wings and tail unit should be firmly secured in place. It is a good general rule for beginners that these surfaces should be glued and not attached with rubber bands, though we have seen a few kits, designedly for novices, where this precaution is not taken. There is little more embarrassing than to have mainplane lifting up and down in flight or tailplane wobbling from side to side. If these items are secure there remain controls to be checked. Control-plate is a frequent source of breakdown in flight, especially if pivoted on a threaded bolt and secured by nuts only. These usually work loose and at the most awkward moment the whole plate comes off the pivot! It is important that the securing nuts be soldered in place. If you are not an enthusiastic solderer wind a little cotton round that part of the bolt standing up above the nut and flood it generously with balsa cement taking care to keep it from sticking to the plate. This is not as permanent as soldering, but will do the job quite well. Next comes attention to wheels; these should track properly in line, any tendency from a straight path should always be out of the circle rather than in. Washers or other wheel retaining device should be checked as the loss of a wheel will often mean at least loss of a prop—and these can be lost easily enough without additional methods. Finally engine mounting should be checked to see that holding-down bolts are secure and that



Assistant Editor Hundleby practises what we preach by a careful check over of drop-off undercarriage fitting before starting up for a flight.

any offsetting is towards the outside of the circle. Airscrew should be adjusted to stop in a horizontal position to minimise risk of breakage on landing, and should be tested for ground clearance with tail held up parallel with datum line. About one inch between prop tip and ground will allow enough for average surface bumps. Next drill is to make sure the controls operate freely without binding anywhere, and that there is no way of them over-running and becoming jammed. Lines can then be attached, and must be checked to make sure that held in a normal position with the handle upright they are exactly the same length. With the thumb at the top of the control handle it should be pulled with a twisting motion towards the body to give "up" and away from the body to give "down." Until a reasonable proficiency is obtained no such wrist movements should be attempted, however, but the arm held out quite straight and raised or lowered for up and down movement of elevators. Lines being laid out on the ground, checked for twists and snags, should again be tested on controls to make certain handle is held right way up, and that controls are still free. It is a good idea to have a handle so shaped that one side is the obvious right way up, and so avoid any accidental change when taking off. We use a handle shaped rather like a £ sign—which must be held "pound way up" but many of the proprietary handles also have basic differences which will help the novice.

There are still one or two points to consider before actually flying. There is the question of lines: whether to use wire or thread lines or one of the multi-strand non-kink lines. If the model is in the under 2.5 c.c. category, then we suggest thread for the first flights—though it will not satisfy once some proficiency is gained. It is less liable to snags and kinks and so gives one less initial worry, but certainly adds

quite a bit of drag to the model. Multi-strand non-kink should not be used for anything under 5 c.c., it is too heavy and too thick and may so seriously impede flight as to hazard the machine in unskilled hands. Again, if wire is to be used, check the wire table and do not use any that is too thick—weight and drag soon builds up.

Next point is—do be patient. If it is windy pack up the box and go home again, otherwise there may not be much left worth packing. Wind up to 8 m.p.h. (Beaufort Scale 2-3) is quite safe for first hops, but if there is the slightest breath be sure that a start is made *down wind*—that is to say, in the opposite direction to which you would launch a free flight model. Model should be placed so that it travels about one-eighth of a lap before coming directly down wind. It should then be airborne before it comes into the wind, that is in not more than half a lap.

Let us get you back on the tarmac ; ready to take off after a final briefing. First and most important point to get very firmly fixed in the mind is that *the model cannot prang when it is going up*. Very few flyers appreciate this light-hearted comment at its real worth. But it is very true. We need only start to worry when the machine is coming down. For that reason do not be too long about letting the model take off. Give your assistant the signal to let go, *step back to keep lines taut* and you are away, with the model rolling nicely on tarmac, tail off the ground running fast down wind, and you wondering about when it should be airborne. But do not be too eager about it either. This is an equally common fault—giving full up, and as our American

Not everyone will be lucky enough to have a hangar like this for flying, which makes any meeting independent of the weather. Local drill halls, however, make a good substitute.



friends so succinctly put it, "flying to the end of the lines." What happens with full up is that the model either goes straight up, loses forward flying speed, and stalls or is frantically over-corrected by the horrified pilot and hits the ground with a bang. A third alternative is that, having plenty of power in hand it does not stall, but continues up and up until it is vertically overhead in the beginning of a wing over that he would dearly like to produce in his later more skilled period, but which now does nothing but embarrass him. Well, we warned you! *It need not be disastrous* if you keep your head! Step back smartly, neutralise the controls and *watch the model*. As it comes right over your head and starts on its downward path, keep stepping back, and give up control, which should bring the model on to an even keel and start it on a rational circuit. The object of stepping back is two-fold. First, in an involuntary wingover like this it is possible the model will go over behind your head and thus become unsighted when you will have not the faintest idea what is happening at all until you hear the clunk! Again, in its initial burst of freedom it may have become inverted, in which case, if you see this, give it *down control* as it comes out from its overhead swing. You will probably have given it up instinctively already before noticing its inverted position, which means the model will now be hurtling earthwards in a vertical dive. By giving it down at the last moment (which, of course, with an inverted machine is really up!) it is unlikely that you will avoid a prang altogether, but should get away with a broken prop and perhaps a bent fin.

But none of this alarming picture need happen if you don't give full up at the take-off. With an engine well matched to the aircraft it should be possible to take-off in under half a lap without giving any appreciable up elevator. In other words, *let the machine fly itself off the ground!* Allowing for those weaknesses common to all of us, we cannot expect you to leave well alone to that extent, and your probable first take-off will be somewhere between the dreadful example and the perfect job—you will undoubtedly give too much up, but not so much, we hope, as to be painful. The model then will fly upwards—though happily in a circular path—far more steeply than you had bargained for. Your immediate instinct is to give lots of down, and then the ground is

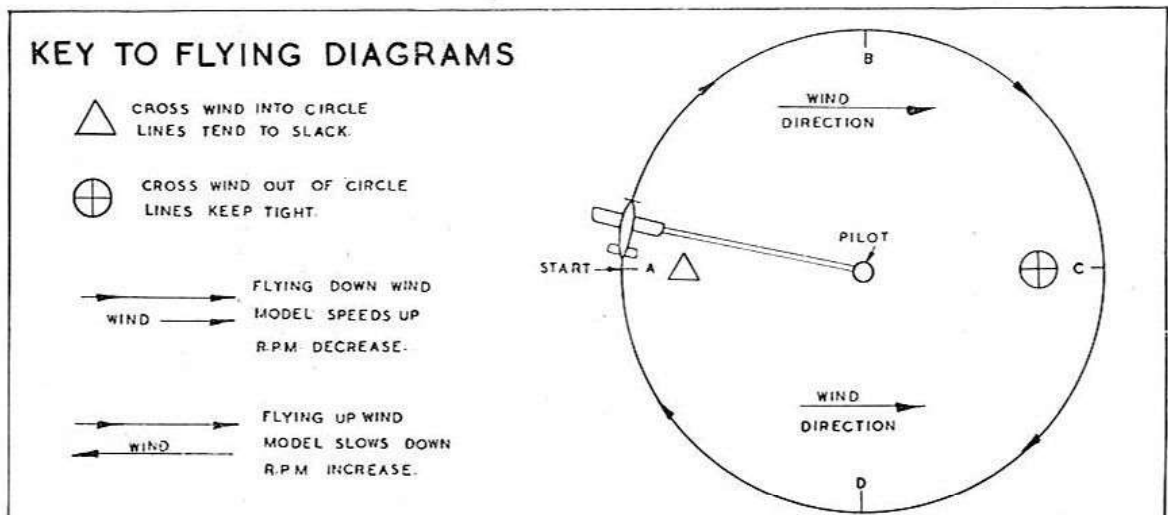



coming uncomfortably close in a dive, and up you go again. With luck, little wind, and a good model, you should be able to flatten out these extremes in a few circuits and eventually get in a few laps of fairly level flying.

If your nerves are strong enough, however, it is better to ease out that terrifying initial climb more gradually, levelling it off with the lines and the ground making an angle of about  $45^\circ$ . Fly round at this height and then gently lower your outstretched arm which will bring the model lower and lower. After a few laps you will appreciate how little control is necessary to make the model rise or climb gently, but for your first flight or two do not attempt anything more ambitious than level flying at various heights. You will notice, even if the wind is very slight, that the model tends to climb as it comes into wind, which, as in a free flight model, is what you would expect. To preserve complete control then, you should dive slightly into wind—just enough to maintain your height without climbing, and then climb slightly on the downwind part of the circuit. This should become second nature to you, for, later on, when you try stunting, all your manoeuvres will take place on the downwind side of the circle.

Until you have had quite a number of flights you will find the business makes you quite giddy—short lines more so than long ones. A lot of this dizziness can be overcome by watching the model and not the background, and in time you will not notice the feeling at all. Just at first, however, it is unwise to try and fly with too full a tank of fuel—some of the special control-line tanks have enough for anything up to 15 minutes' flying! As you will not—we hope—be trying any stunts immediately there is no reason why the standard tank as fitted to your engine for free flight should not be used. Most free flight tanks have a capacity of not more than two minutes—and this will be quite long enough for a start, even allowing a good half minute starting and warming up. You will be surprised how long it seems until the motor starts to splutter and you know the flight is nearly over. And so are your troubles for the time being. As the motor cuts, consider quickly just where you are in relation to wind. It is much better if there is any wind to bring it in on the downwind side—just as you started from there—

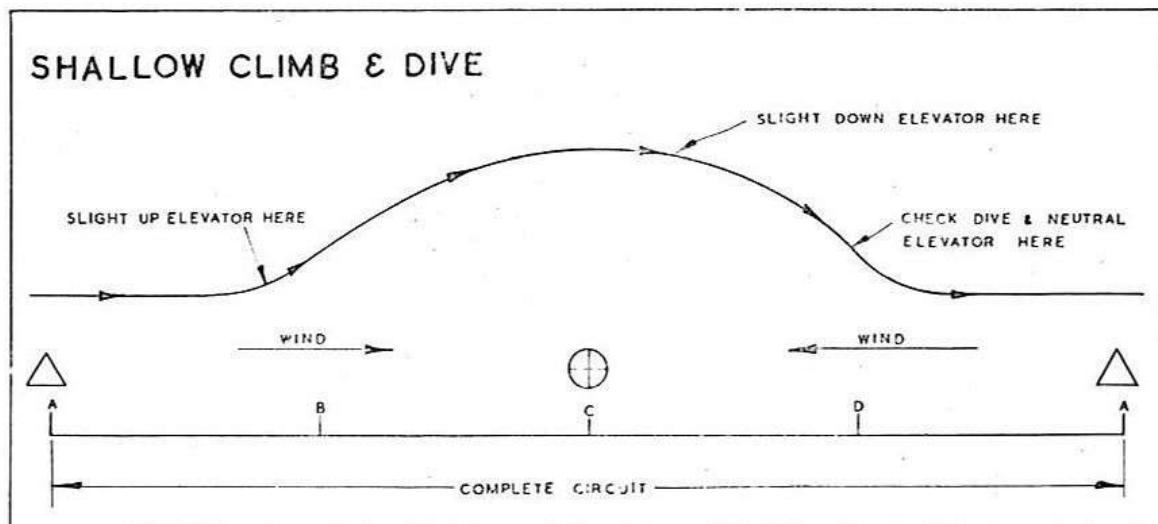

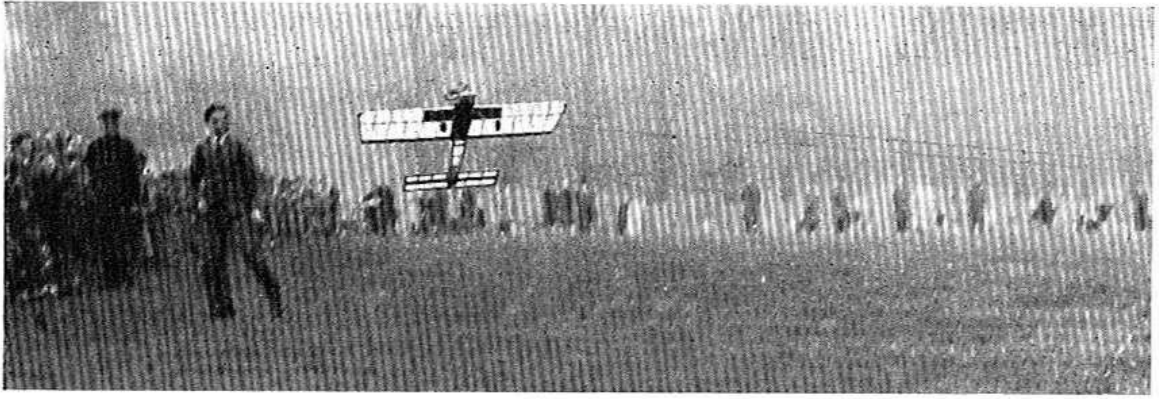

Take off from rough grass. Helper on left has just released model which is already well airborne. Such a take-off is quite easy with the larger sizes of engine.

as your lines will remain taut and you have a good chance of landing on the wheels. If you have some way still to go try to pull the model round with a "whipping" motion, keeping the controls so that it is gliding steadily earthwards; then just before it touches down, give it full up, which should help towards a three-pointer. Quite a number of props get broken in landing, even when the engine has cut, so it pays to take care. Just the weight of the model tipping over on to its prop can easily break it—which, of course, is where the advice on adjusting prop position to stop horizontally proves its worth. As it comes in be sure to step back a pace or two thus helping to keep full control, which you will only have just so long as the lines are taut. This is a point worth emphasis—*you can only control the model with taut lines*. As soon as they go slack, as, for example, when you come into wind and the machine is blown in towards you a little, you lose control and until the lines tighten again there is nothing you can do to change its flight path. Moral of this is *don't let the lines get slack*. If you feel them going slack step back at once until you get positive control again. This should not be much of a problem for beginners flying in calm weather, but just as soon as you get ambitious and try a model out on a bad day you will learn all about slack lines in next to no time.

So far we have spoken only of what the pilot should do on his first outing. Nearly as important is the conduct of the mechanic, if we may so describe the assistant charged with letting go the model at the appropriate time. It is a help—and evens out the work—if the assistant can do the actual starting of the engine himself. Otherwise there is that rush down the lines with the engine going splendidly, a hasty grab at the handle, and the wretched engine peters out again. After doing this two or three times it is small wonder the pilot is a little flustered and unable to give of his best, or even picks up the handle upside down! No! if possible the assistant should do the actual starting, with the pilot already at the handle end ready to take off quietly and without fuss when the model is ready to go.

Having started the engine satisfactorily the assistant should not release it until he receives a signal from the pilot. This is important. If he just lets go when he is ready the man at the other end may well be caught napping and have to make a very flurried take-off. Note also that we say *release* the model. There is a school of thought that says

a gentle push is to be recommended, but we have not found the advantages anything like up to the disadvantages of a push. Sometimes it is too vigorous and puts the model over on to its nose ; at other times it sends the model rolling into the circle with slack lines. All things considered it is better to let the model go without pushing—then whatever happens is in the hands of the pilot. The only exception to this, we would say, is in the case of speed models on a dolly where a *skilled* helper can do a lot to assist take-off by running round steadying the outside wing-tip until a fair speed has been got up. But this should hardly affect the novice flyer.

Elementary flight technique can then be summed up as follows :

- (1) Check model including control plate, wheels and engine.
- (2) Check lines for snags and free up and down movement.
- (3) Start engine ; check " up " is up and " down " is down !
- (4) Signal release of model.
- (5) Keep lines taut, stepping back if necessary.
- (6) Let model take itself off with only very slight elevator up assistance.
- (7) Correct too much up elevator.
- (8) Fly level.
- (9) Climb down wind ; dive up wind.
- (10) Remember to keep lines taut always by stepping back.
- (11) When engine cuts try to bring model in downwind by whipping if necessary.
- (12) Give up elevator immediately before wheels touch down.

One of the beauties of control line flying is that flights can be made almost anywhere. But that does not mean some places are not better than others. If any choice exists it is as well to have the most suitable. Best of all is a nice smooth hard tarmac or concrete surface for the take-off and soft turf for landing. Such conditions will be found on a full size aerodrome, where take off can be made from the runway, and then stepping back down wind the model can alight on a grassy portion

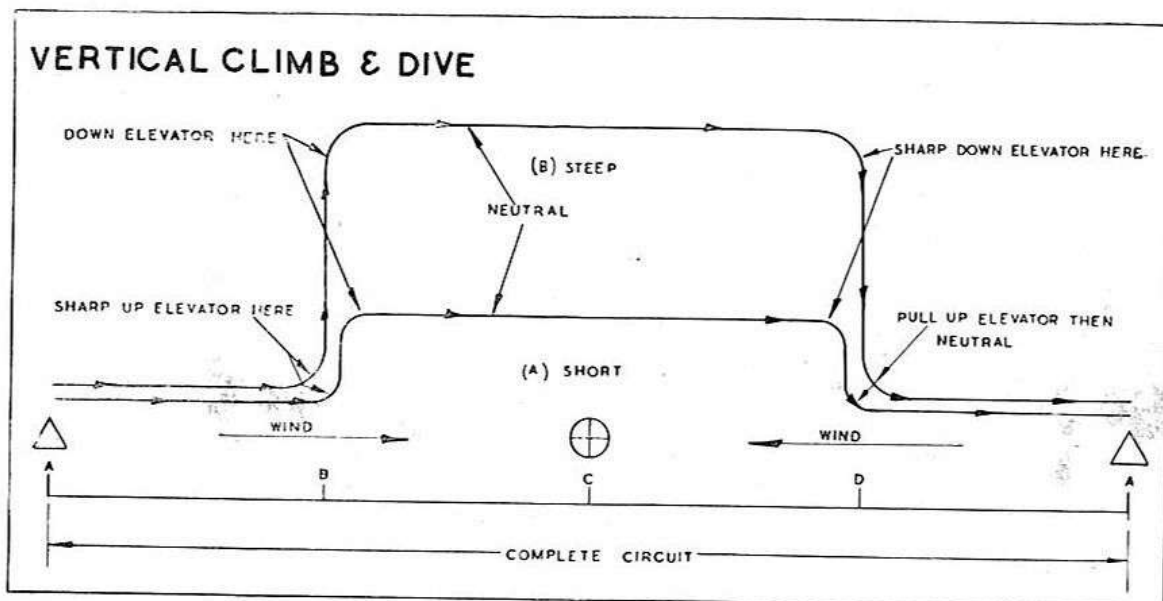

of the airfield. Such conditions will not be available to many, and so a compromise must be sought. A large school playground wants quite a lot of beating for smoothness—though it is a little hard for heavy landings. A hard tennis court, preferably of the asphalt kind, is good. The loose dirt sort that requires watering is bad for the engine and we doubt if control line models would be popular with the groundsman! Cricket pitches are good for an all grass take-off, but unfortunately the same remarks on groundsmen apply; so enthusiasts had better be content with some smoother part of the outfield and not desecrate the actual wicket. Housing estate roads, where building has not caught up with the road, make good take-off spots. For small—1 c.c. and under—models there is little to beat an indoor flight in a fair-sized gymnasium or badminton hall. For the sake of repeat performances, however, do take care to lay down a sheet of felt or lino where engine starting and tank filling takes place—people are quite touchy about their floors!

We have assumed so far that the novice flyer has brought a typical trainer along for his first flights. Such a machine will be moderately powered with an engine of sufficient size but nothing special to make it "a hot ship." In the same way elevators will be of moderate size only, with comparatively small up and down movement. In other words, everything possible will have been done to save the beginner from himself. With the worst will in the world it would be impossible to break speed records with such a model or put it through many of the stunts in the book. At any rate this is what we hope has been brought along. It is foolhardy, to say the least, to start flying with some super speed design or highly sensitive stunt job—it will be smashed up before you have ever had a chance to fly it properly. The beginner cannot do better than make up any of the better "trainer" kits advertised, choosing one to suit his engine. In this early stage the qualifying flights will be the same whether it is intended to specialise in stunt or speed. First step is to become completely confident in the handling of the machine. This may come if you are a thoroughly adaptable type of the "born pilot" class after only one or two flights. More likely, if you are average—or a bit above average—it will take half a dozen or more flights to begin to get the feel. This is the time to beware. Over confidence will put you back if you are not very careful. By now you will have quite got the idea of take-off and landing, and each flight will be quite a

Heading for disaster! Flyer can be seen running hard in an endeavour to regain control of his model coming in on a slack line.



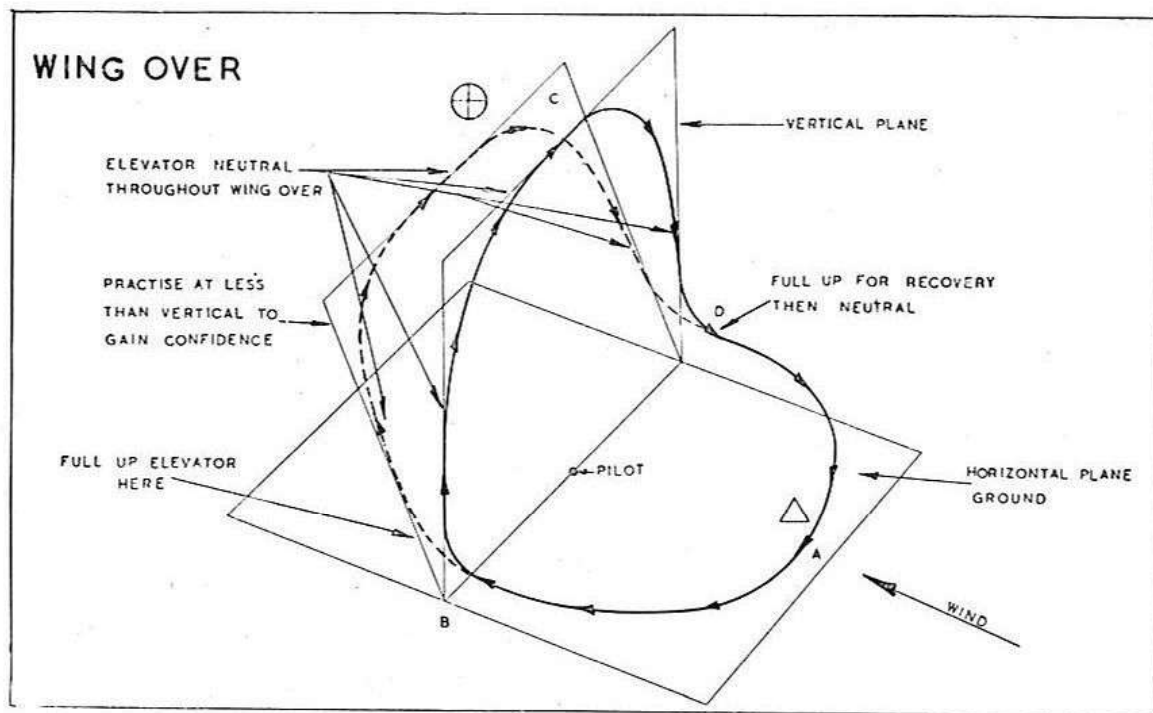

pleasant pattern of climbs and dives, which you can now produce at will—not spend a couple of laps levelling off! Now for a nice loop or awing over you say, and, hey presto, it must be recorded that the first three-quarters of the manoeuvre were perfect, if only you had started higher up! Over confidence may have laid you low even before this stage, as you try just how close you can skim the grass, and find it too close by several inches. Can we be thoroughly practical? Try to make up your mind, and keep to it, to put in one hour—sixty minutes' solid flying before you attempt anything more than simple dives and climbs. With the average standard tank this means about thirty flights, or say two afternoons out. During this time you will probably, indeed, almost certainly, have broken several props, dented several parts of the model, and done all the things we have warned you against at least once, but you will have got the hang of flying without thinking consciously of what you are doing all the time. Then and only then is it safe to embark on more ambitious work.

A wingover can be your first effort. Don't try to get a perfectly vertical climb right overhead for a start. Make a few pecks at it first, bringing the model up into a climb *downwind* over at about  $60^\circ$  and so nicely levelled off before you get upwind again. Then again just a little steeper, about  $5^\circ$  at a time until suddenly you find the man on the outside of the circle applauding a really good effort. Just between ourselves, the wingover is one of the hardest manoeuvres to do really well, in fact even the experts do not always produce a true "vertical" whatever they may think themselves! Having mastered the wingover—or shall we say the "near wing over," next stunt might well be the loop—simple outside loop executed on the climb. Secret here is to *consciously feel the loop all the way*. Give it good firm up elevator until it is past the vertical and coming over, then ease the controls a little to give an opportunity to pick up speed for the downward rush, then full up ele-

vator again until you see it is coming out with enough air in hand—and lo! and behold! you have done your first successful loop. Or have you? Running out of air is the most common trouble with first loops. Either it has been commenced too near the ground, or controls have not been really felt all the way. It is surprising how that ground does loom up—usually just enough to catch the undercarriage and mean one more prop. But persevere, and do make the first effort over turf if you can, it is so much softer than concrete! This mainly applies to the smaller sizes of engine where there is not enough margin of power to really whip off the loops. With a good 5 c.c. diesel or 10 c.c. petrol engine nicely tuned it seems so much simpler—though the damage is proportionately greater if things do go wrong!

Speed merchants will wish to progress after their apprenticeship to the take-off dolly; which is also quite a good thing for stunt merchants—then you don't (theoretically) catch the undercarriage at the end of the first loop. There are two types in general use: the three-wheeler tricycle on which the wing and fuselage belly rests, and the two-wheel type with one or two prongs fitting into holes in the fuselage. The latter is probably better for first attempts provided they are being made from comparatively smooth ground. On rough ground the three-wheel dolly with good large airwheels is the better choice. The model will career round with its take-off apparatus and become airborne still carrying it. The tricky moment is when it falls, for there will be an immediate surge of power by the lighter wingloading, which will tend to give a nose up effect to the model.

Another trouble with dollies is that bumpy ground may tend to dislodge the model before it is going fast enough to become airborne. This usually means another prop. There is no magic word to avoid it. The secret here is in the design of an efficient dolly. Some experts recommend that the wings and fuselage merely rest on a shaped trough, becoming airborne as soon as it has lifted clear of the retaining arms holding the wing leading edges from sliding forward. Better, perhaps, is

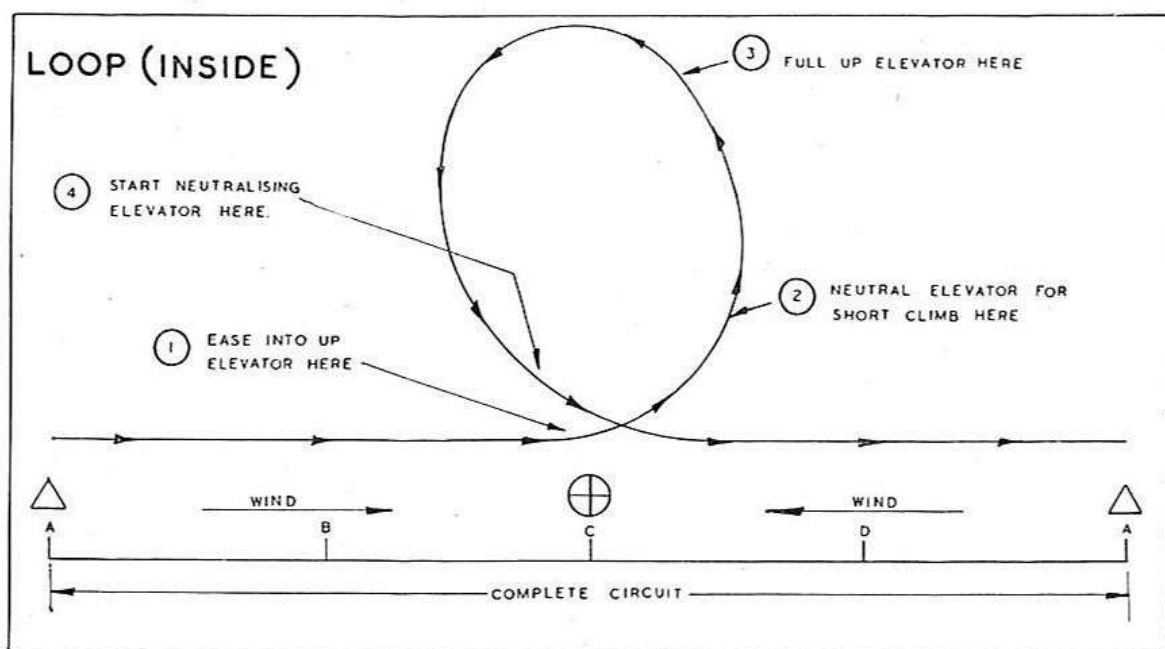

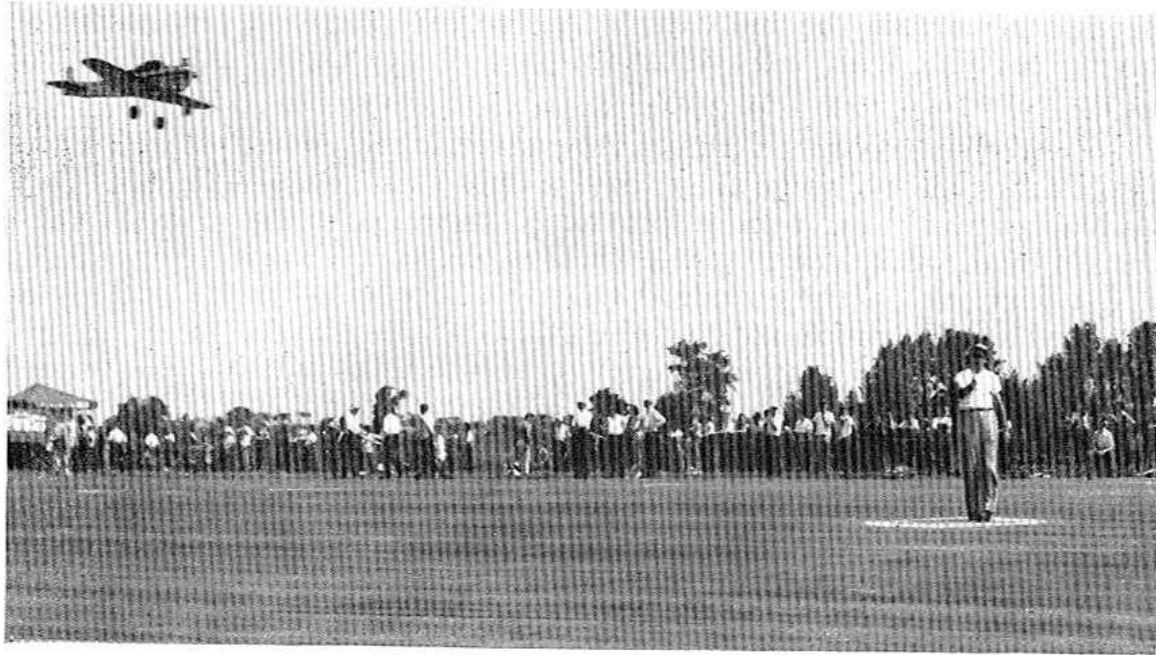

Well cut grass and adequate crowd control make this flyer's lot a happy one. Whitewash circle, in which he stands, gives him an idea of relative distances. He is flying right handed in an anti-clockwise direction across the body, which we recommend as the more comfortable method.

the method where the dolly is equipped with prongs, like the two-wheel drop-off undercarriage, as this seems to give more positive fixing until the two parts are really ready to separate. A disinclination of the dolly to drop away can sometimes be cured by weighting it with solder or the like, but this somewhat retrograde step should not be taken until free movement from any pronged fittings has been checked. It is a lesson in itself to watch the speed experts setting up their models on a dolly—everything is carefully tested for each flight, and the oil-can ever ready to ease any recalcitrant part.

Our advice on first steps to flying should be enough to set the complete novice on his way without undue heartburning or the destruction of more than a normal number of props and odd parts. If he is fortunate enough to have a skilled friend willing to assist then his task will be that much lighter. Nothing that we have said need be unlearned or ignored. The skilled friend *may* be able to help his take-off with a knowing push—that is up to him; he may, equally well, pass the novice on to more ambitious manœuvres before completing his one hour solo—that again is up to him. But he will never be able to fly for him—that the novice must learn himself. The double ended control handle may prove useful in nearly flying for him, but hints on its use are superfluous as the skilled helper will know best how he likes things.

One last point before passing on—are you left handed? This is quite a point. We are, and found our own mortality rate far lower when flying in a clockwise direction than anti-clockwise; whilst colleagues who were right-handed found anti-clockwise the happier direction. It seems easier to follow the model round in a forwards direction, that is with it flying across the front of the body, than to be turning round backwards with the model always about to disappear round the back of the head. Provision for the way round must be made quite early in building—and there is no reason why this should not be changed, if

necessary, to suit the individual. There are plenty of arguments in favour of flying with and against torque ; choose those that enable you to fly your own " natural way."

We have refrained from giving advice on advanced flying. When pilots reach such a stage they require only two things—courage to try, and opportunity for regular practice. Included in the appendix are details of the usual flight patterns possible, which are all elaborations and variations on the standard themes of flying normally and flying inverted and the process of changing from one stage to the other. Speed flying requires less practice, perhaps, on the field, but certainly much more work at home perfecting the model for its flight.

In conclusion, may we wish all our readers the best of luck in their flying—sweet revving motors and happy landings !



The flying diagrams used in this chapter are based on *Mercury Magnette* instruction leaflet by Henry J. Nicholls, to whom grateful acknowledgment is made.

THE END



## INDEX

	<i>Page</i>		<i>Page</i>
AILERON CONTROL ... ..	63	Don ... ..	17
Airscrew breakages ... ..	9, 38	Drop off u/c ... ..	68, 69
Airscrew carving ... ..	86, 87	Drag ... ..	24, 31
Airscrew, folding ... ..	68	Drone ... ..	16, 22
Airscrew fragmentation ... ..	79, 90	Durofix ... ..	59
Airscrew materials ... ..	87		
Airscrew, metal ... ..	87	EATON BRAY ... ..	14, 15
Airscrew repairs ... ..	87, 88	E.D. ... ..	10, 40
Airscrew, toothpick ... ..	84	Elevator ... ..	19, 61
Air wheels ... ..	70	Elevator area ... ..	62
Ajustalyne handle ... ..	96	Elevator colour ... ..	65
Allen, Dennis ... ..	22	Elevator horn ... ..	56
Alloy crutch ... ..	37	Elevator movement ... ..	62, 65
Alloy mounts ... ..	38	Enamelled wires ... ..	97
Amco ... ..	25	Engines ... ..	12, 75, 76, 77, 78
American elevator ... ..	62	Engine design ... ..	75, 79
Antiblanketing fin ... ..	64	Engine size ... ..	17, 23, 75, 80
Arden ... ..	76	Engine mounts ... ..	39, 81
Area of tailplane ... ..	62	Engine starter ... ..	84
Aspect ratio... ..	47	Engineer, model ... ..	80
Assistant ... ..	104, 109		
Axle, u/c ... ..	70		
		FAIRLEADS ... ..	49, 57, 58
BAKER'S FLUID ... ..	70, 96	Fin ... ..	63, 64
Balance ... ..	21	Finish ... ..	36
Bambara ... ..	17	Finless models ... ..	64
Bandsaw ... ..	33	Flatfish ... ..	40
Barnstormer ... ..	27	Flexible leads ... ..	53
Bassett, Maxwell ... ..	79	Flight controller ... ..	54
Beam mounting ... ..	37, 39, 81	Flight failures ... ..	99
Beaufort Scale ... ..	101	Flight technique ... ..	105
Beginners ... ..	13	Flux ... ..	40
Belgium ... ..	10	Flounder ... ..	26, 37
Bicycle spokes ... ..	51	Flying field ... ..	9, 106
Biplanes ... ..	41, 47, 61	Folding airscrew ... ..	68
Boom ... ..	38	Forster ... ..	76, 78
Brasso ... ..	36	Fox ... ..	76
Brown, Jnr. ... ..	79	Fragmentation ... ..	79, 90
Buxton, Ted ... ..	27	French engines ... ..	10, 77
		Frog ... ..	14, 16
CABANE ... ..	41	Fuel, climatized ... ..	85
Californian group ... ..	21	Fuel seepage ... ..	14, 36
Canard ... ..	27, 38	Fuselage protection ... ..	68
Centrifugal force ... ..	24		
Centre of Lift ... ..	19	GARAMI ... ..	26, 37, 63
C.G. ... ..	21	Giddiness ... ..	103
Clark, Y. ... ..	90	G-Line ... ..	7, 10, 53
Climatized fuel ... ..	85	Glow Plug ... ..	9, 77, 78
Climb ... ..	103	Goats ... ..	8
Clubs ... ..	99	Gouge ... ..	33
Coasby, J. W. ... ..	27	Grant, C. H. ... ..	28
Cock, Pete ... ..	40, 64	Guide line ... ..	9
Cole, Henry ... ..	29		
Constant pitch ... ..	88	HALFAX ... ..	16
Control Plate ... ..	33, 53	Hand Launch ... ..	73
Control Wires ... ..	21	Handles ... ..	95, 96
Cowls ... ..	39, 81, 82, 83	Hardwood wheels ... ..	70
Crutch ... ..	36	Hassad ... ..	79
		Hinge, elevator ... ..	59
DE BOLT, HENRY ... ..	23, 83	Hollow-log ... ..	25, 31
Delmo ... ..	16, 77, 78	Home-made U-Reely ... ..	96
Design ... ..	13, 19	Horn ... ..	56
Dihedral ... ..	46	Hornet ... ..	10, 76
Dooling ... ..	76	Hot Rock ... ..	15, 19
Dolly ... ..	71, 108, 109	Humidity ... ..	85
Dolly jig ... ..	71	Hundleby, H. G. ... ..	26, 37

	<i>Page</i>		<i>Page</i>
INCIDENCE ... ..	22, 46, 47, 63	Roller control ... ..	7, 10, 53
International M.A. ... ..	15	R.P.M. ... ..	78
Italian engines ... ..	10, 76	R.T.P. flying ... ..	62
		Rubber models ... ..	29
		Rusher, Ray ... ..	97
		Russell, D. A. ... ..	89
JET ENGINES ... ..	28, 80, 81	SABRE ... ..	16
Jig for dolly ... ..	71	Safety line ... ..	73
Jigsaw ... ..	33	Scale models ... ..	28, 45
Jincker ... ..	17	Semi monocoque ... ..	35
Joystick control ... ..	54	Shulman ... ..	41
		Sidewinder ... ..	24, 81
KAN-DOO ... ..	40	Skid ... ..	73
Kipper ... ..	26, 37	Slabsider ... ..	38
Kits ... ..	12	Slack lines ... ..	104
		Slagle, Dave ... ..	22
LEAD OUT WIRES ... ..	49, 57, 58	S.M.A.F. ... ..	24, 29, 80
Left handed flying ... ..	109	Smith, Phil ... ..	15
Lill pins ... ..	36	Soldering ... ..	40, 56, 72, 99
Linden formula ... ..	22	Span ... ..	49
Line drill ... ..	65, 96, 100	Spark ignition ... ..	77
Line drag ... ..	93	Speedee ... ..	15
Lines... ..	94	Speed flying ... ..	10, 108
Line tests ... ..	65, 96	Speed models ... ..	20
Lines, unwinding ... ..	94	Spinners ... ..	85, 88
Loop ... ..	107	Spitfire ... ..	25
Loop, Line ... ..	57, 95	Stanzel, Vic ... ..	7, 53
L.S.A.R.A. ... ..	89	Starter, engine ... ..	84
		Steel wire lines ... ..	93
MADWELL ... ..	76	Stepping back ... ..	102
Magnette ... ..	15	Struts ... ..	41
McCoy ... ..	10, 76	Stunt elevator ... ..	62
Metal airscrews ... ..	87	Stunt models ... ..	20
Metal wheels ... ..	70	Stunter ... ..	15
Meteore ... ..	77	Super Cyclone ... ..	21, 76
Micron ... ..	10, 16, 77	Super Delmo ... ..	77
Mills ... ..	16, 25, 65	Super Tigre ... ..	11, 76
Moment arm ... ..	19	Symmetrical sections ... ..	44
Monarch ... ..	17	TAIL MOMENT ARM ... ..	19
Monocoque ... ..	35	Tailplane ... ..	61
Moore, Rupert ... ..	83	Tailplane area ... ..	61, 62
Movo ... ..	11, 76	Take-off ... ..	104
Moulds ... ..	83	Tanks, standard ... ..	83
Multi-line control ... ..	97	Tanks, stunt ... ..	84
Multistrand line ... ..	100	Taut lines ... ..	101, 104
		Third line ... ..	97
NANCY ... ..	14	Thomas, F. B. ... ..	97
Nicholls, Henry J. ... ..	15, 22	Thread lines ... ..	93, 100
Nipper ... ..	14	Toothpick airscrew... ..	84, 90
Non-helical pitch ... ..	89	Trainer ... ..	16
Nordec ... ..	10, 76	U-CONTROL ... ..	7, 10, 52, 55
Nun's veiling ... ..	83	U-Reely Handle ... ..	96
		Undercarriages ... ..	67
OFFSET FIN ... ..	63	Undercarriage, drop-off ... ..	68, 69
Ohlsson ... ..	76	Undercarriage fairing ... ..	68
O.K. ... ..	76	Undercarriage, fixed ... ..	68
Old Timer aircraft ... ..	8, 48	Undercarriage whisker ... ..	70
One man launch ... ..	97	Unwinding lines ... ..	94
Outline fuselage ... ..	40	WALKER, JIM ... ..	7, 10, 52, 94, 96
Owat... ..	16	Walker, N. K. ... ..	89
		Watkins ... ..	17
PADDLE BLADE ... ..	90	Warne, Bill ... ..	85
Paxolin u/c boxes ... ..	67	Weight ... ..	22
Payne, P. R. ... ..	27, 88, 89	West Essex Club ... ..	22
Pioneers ... ..	7, 11	Wheels, air ... ..	70
Pivot point ... ..	83	Wheels, rubber ... ..	70
Prefabrication ... ..	15	Whipping ... ..	104
Pusher ... ..	27	Whisker, undercarriage ... ..	70
		Wind ... ..	9
RADIAL MOUNTING ... ..	34, 39, 81	Wing loading ... ..	44
Radius ... ..	15	Wingover ... ..	107
Rea ... ..	10	Wing sections ... ..	22, 43
Reel ... ..	95	Wing shape... ..	49
Reel, Jim Walker ... ..	94	Wing strength ... ..	50
Reel, U-Reely ... ..	96	Wire undercarriage ... ..	67
Reynolds number ... ..	45	Worcraft ... ..	17
Rival ... ..	17	YOUTH ... ..	9

## APPENDIX I

## SPEED TABLE

Half Mile Distance

Time	Speed m.p.h.	Time	Speed m.p.h.	Time	Speed m.p.h.	Time	Speed m.p.h.	Time	Speed m.p.h.
12.0	150.00	15.5	116.15	19.0	94.74	22.5	80.00	26.0	69.23
1	148.76	6	115.4	1	94.24	6	79.65	1	68.97
2	147.5	7	114.65	2	93.73	7	79.3	2	68.71
3	146.3	8	113.9	3	93.24	8	78.95	3	68.46
4	145.1	9	113.2	4	92.75	9	78.59	4	68.18
12.5	143.95	16.0	112.5	19.5	92.27	23.0	78.24	26.5	67.92
6	142.9	1	111.8	6	91.78	1	77.9	6	67.66
7	141.75	2	111.1	7	91.35	2	77.56	7	67.4
8	140.62	3	110.45	8	90.91	3	77.24	8	67.15
9	139.55	4	109.8	9	90.46	4	76.92	9	66.9
13.0	138.5	16.5	109.15	20.0	90.0	23.5	76.6	27.0	66.67
1	137.4	6	108.5	1	89.56	6	76.28	1	66.43
2	136.3	7	107.85	2	89.12	7	75.96	2	66.18
3	135.3	8	107.2	3	88.67	8	75.64	3	65.94
4	134.3	9	106.55	4	88.23	9	75.32	4	65.70
13.5	133.35	17.0	105.9	20.5	88.81	24.0	75.0	27.5	65.46
6	132.4	1	105.26	6	87.39	1	74.7	6	65.22
7	131.4	2	104.6	7	86.97	2	74.41	7	64.98
8	130.4	3	104.05	8	86.54	3	74.09	8	64.78
9	129.49	4	103.4	9	86.12	4	73.77	9	64.54
14.0	128.57	17.5	102.85	21.0	85.71	24.5	73.47	28.0	64.29
1	127.68	6	102.3	1	85.29	6	73.17	1	64.05
2	126.8	7	101.7	2	84.87	7	72.87	2	63.82
3	125.9	8	101.1	3	84.48	8	72.58	3	63.59
4	125.0	9	100.55	4	84.08	9	72.29	4	63.37
14.5	124.15	18.0	100.0	21.5	83.71	25.0	72.0	28.5	63.15
6	123.3	1	99.46	6	83.34	1	71.76	6	62.92
7	122.46	2	98.91	7	82.96	2	71.43	7	62.71
8	121.62	3	98.37	8	82.57	3	71.18	8	62.5
9	120.81	4	97.84	9	82.19	4	70.92	9	62.29
15.0	120.0	18.5	97.32	22.0	81.82	25.5	70.61	29.0	62.07
1	119.2	6	96.79	1	81.45	6	70.31	1	61.86
2	118.42	7	96.27	2	81.09	7	70.04	2	61.65
3	117.66	8	95.75	3	80.78	8	69.77	3	61.44
4	116.9	9	95.25	4	80.36	9	69.5	4	61.23

**ACKNOWLEDGMENT :** Appendices giving S.M.A.E. Control Line Regulations, Schedule, and Draft Rules are reprinted from the S.M.A.E. Handbook, 1949, to which due acknowledgment is made.

## APPENDIX II

## S.M.A.E. AEROBATIC CONTEST SCORING SCHEDULE

<i>Manoeuvre :</i>							<i>Grade</i>	<i>Points</i>	<i>Max. Poss.</i>
(a)	Starting (take-off within 1 min.)	...	...	...	...	...	Good	5	5
(b)	Take-off	...	...	...	...	...	Rough	3	5
							Poor	1	
(c)	Level flight (Two laps at 6ft. alt.)	...	...	...	...	...	Level	5	
							Wavy	3	5
							Poor	1	
(d)	Climb (to be through 15ft.)	...	...	...	...	...	Vertical	10	
							Steep	7	10
							Shallow	3	
(e)	Dive (to be through 15ft.)	...	...	...	...	...	Vertical	10	
							Steep	7	10
							Shallow	3	
(f)	Wingover (Bisecting circuit vertically over pilot)	...	...	...	...	...	Vertical	15	
							Steep	10	15
							Shallow	5	
(g)	Consecutive Inside Loops (entire series to be completed within $\frac{1}{4}$ lap, line angle not to exceed 60°. Shaky loops 2 points each.)	...	...	...	...	...	1 Loop	3	
							2 "	7	
							3 "	12	25
							4 "	18	
							5 "	25	
(h)	Consecutive Outside Loops (as above. May be entered from normal or inverted position.)	...	...	...	...	...	1 Loop	25	
							2 Loops	30	
							3 "	35	45
							4 "	40	
							5 "	45	
(i)	Inverted Flight	...	...	...	...	...	1 lap level	10	
							1 lap wavy	7	
							2 laps level	15	25
							2 laps wavy	10	
							Smooth recovery	10	
							Rough "	7	
(j)	Horizontal Figure Eight (within $\frac{1}{2}$ lap, shaky manoeuvres lose 3 points each)	...	...	...	...	...	One	25	
							Two	30	35
							Three (Max.)	35	
(k)	Vertical Figure Eight	...	...	...	...	...	Good	30	30
							Rough	20	
(l)	Overhead Figure Eight (centre of "8" must be overhead of pilot.)	...	...	...	...	...	Good	30	30
							Rough	20	
(m)	Square Loop (horizontal portions of loop to be $\frac{1}{4}$ lap)	...	...	...	...	...	Good	30	30
							Rough	20	
(n)	Special Manoeuvre (must be fully specified in flight pattern sheet)	...	...	...	...	...	Best man	15	15
							(Others graded accordingly)		
(o)	Landing (to be judged by approach if over bad ground)	...	...	...	...	...	Good	10	
							Rough	7	10
							Poor	1	

Maximum possible

295  
points

## APPENDIX III

## TYPICAL CONTINENTAL AEROBATIC CONTEST RULES AND SCORING SCHEDULE

1. During each flight (of 3) the entrant may execute the manoeuvres set out in the rules, but he may not repeat the same figure more than three times during the meeting. The selected manoeuvres will qualify for points only if carried out during the first twenty laps of each flight.
2. The meeting will begin with the allocation of numbers. A corresponding number will be carried on the back of each concurrent, who will not be permitted to start without such designation. A draw will be made for order of flying.
3. Motors must be started by hand by the flyer of the model.
4. In the case of a tie, the entrant with the higher number of points for appearance will be judged the winner.
5. The organisers decline any responsibility for accidents to flyers and spectators if such are caused by other than their members.
6. The meeting will only be stopped for bad weather on a vote by the judges.
7. Before flying the entrant shall submit a list of figures he will execute in the order given in the schedule.
8. Schedule of points.

		<i>Total possible</i>
(A)	<i>Appearance</i> ... ..	100
(B)	<i>Dexterity</i> (i) Take off from a nominated spot (4 pts. penalty for each metre of error) ... ..	20
	(ii) Passing between two points 1.25m.—1.75m. from the ground ... ..	10
	(iii) Passing between ground and a point .75m. above ... ..	20
	(iv) Landing on a nominated spot (8 pts. penalty for each metre of error) ... ..	40
	(Any model touching ground with its wheels will be considered to have "landed.")	
(C)	<i>Originality.</i> (i) Trailing of ribbons or flags in flight ... ..	20
	(ii) Dropping of single or groups of objects ... ..	20
	(iii) Glider towing ... ..	30
	(iv) Emission of smoke trails for at least 1 lap ... ..	40
	(v) Pick-up of objects from the ground in flight ... ..	50
(D)	<i>Aerobatics.</i> (i) Dive ... ..	5
	(ii) Climb (min. 3 metres) ... ..	10
	(iii) Vertical climb ... ..	20
	(iv) Touch down for $\frac{1}{2}$ lap (after at least 1 lap flying) ... ..	20
	(v) Dive, touchdown and vertical climb ... ..	30
	(vi) Wingover (vertical over pilot) ... ..	30
	(vii) Vertical S ... ..	50
	(viii) Single loop (inside or outside) ... ..	50
	(ix) Multiple loops (each) ... ..	60
	(x) Inverted flying (min. 1 lap) with recovery ... ..	100
	(xi) Horizontal 8 ... ..	150
	(xii) Vertical 8 ... ..	200
	(xiii) Humorous or crazy flying (20 laps) ... ..	150
(E)	<i>Team Flying.</i> (i) Two flyers. Simultaneous take-off on opposite sides of circle (20 laps with at least 2 passings) each flyer ... ..	100
	(ii) Three flyers. Simultaneous take-off from equally spaced stations on circle. (20 laps and 2 passings minimum) to each flyer ... ..	150

## APPENDIX IV

## S.M.A.E. RULES GOVERNING CONTROL LINE FLYING

## General

1. No model shall be flown on any ground unless suitable arrangements are made for the protection and control of spectators.

2. Spectators shall remain at least 25 feet outside the flight path of the model/s.

3. In the event of flight conditions becoming unsafe, the flyer shall immediately cease flying until such time as the situation has been remedied.

4. Before each flight the pilot shall examine his equipment for kinks, wear, etc., and submit the controls to test by exerting a pull on the handle with an assistant holding the model.

5. Flying lines and handles shall conform to the following breaking strain specification :—

Classes I and II	...	15 lb. minimum
Class III	... ..	25 lb. ,,
Classes IV and V	... ..	40 lb. ,,

6. No model shall be flown having a total weight of over 4 lb. or an engine capacity above 15 cc. (Capacity =  $.7854 \times \text{Bore}^2 \times \text{Stroke}$ ).

7. The General Rules governing the flying of Power-Driven models shall apply.

## Speed

8. For contest and record purposes, speed control line models are graded according to engine capacity, and flown on standard line lengths as follows :—

Class I	... 0.00-1.5 c.c.	... 35 feet
Class II	... 1.51-2.5 c.c.	... 35 ,,
Class III	... 2.51-5.0 c.c.	... 52½ ,,
Class IV	... 5.01-8.5 c.c.	... 70 ,,
Class V	... 8.51-15 c.c.	... 70 ,,
Class VI	... Jet or Rocket	... 70 ,,

(Line shall be measured from centre of handle to centre of model, this measurement to be taken as radius and used to calculate speed.)

9. In cases where longer lines than standard are used, speed shall be calculated from the standard line lengths for the particular class, and that figure only recorded.

10. No attempt on Speed Records shall be made without obtaining the sanction of the S.M.A.E., who shall decide if the conditions are suitable.

11. No speed model shall be flown without the use of an Anti-whip Yoke Pylon.

12. Models shall not exceed an altitude of 10 feet during a record attempt.

**Timing**

- 13. (a) All contest or Record attempts shall be times over a minimum course of half a mile.
- (b) Timing shall commence on receipt of a signal from the pilot.
- (c) At least two (for record attempts three) stop watches calibrated in 1/10th seconds shall be employed.
- (d) Any time variation over 1/5th second shall render the flight null and void.

14. At all speed events, all equipment shall be checked for strength and serviceability by an officer delegated for that purpose, and who shall have authority to refuse permission to fly in cases where the required standards of safety are not met.

**APPENDIX V  
WIRE BREAKING STRAINS**

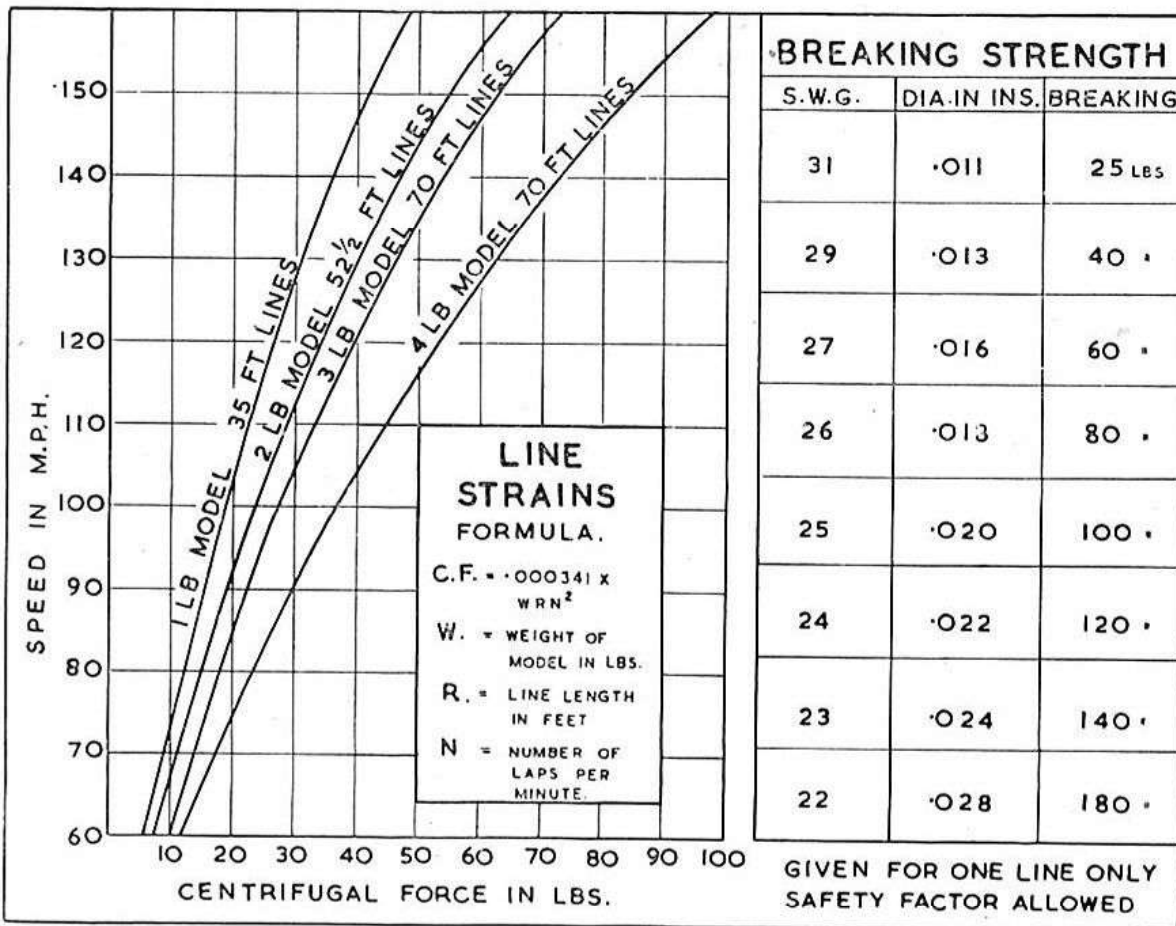

## APPENDIX VI

## S.M.A.E. DRAFT RULES FOR FLYING SCALE CONTROL LINE MODELS

Aware of the increasing interest being shown in Flying Scale control line models, the S.M.A.E. Council present the following initial Rules and Schedule for this class of contest, and trust that many members will try them out during the 1949 season, and forward their opinions gained from experience.

All recommendations received will be carefully reviewed by a special Committee set up to consider the inclusion of this type of contest in the National programme for 1950.

1. The General Rules governing the flying of Power-Driven models shall apply.

2. Entrants shall supply full working drawings, together with full measurement specification of the model prototype.

3. Points will be awarded in each of seven sections as follows :

Absolute scale	...	20	points	} Total possible 280 pts.
Approximate scale	...	10	"	
Excellent workmanship		20	"	
Good	"	15	"	
Fair	"	10	"	

4. The seven sections in which the above points will be awarded are :—

- (a) General appearance
- (b) Fuselage
- (c) Wing
- (d) Empennage
- (e) Landing gear
- (f) Motor mount and cowl
- (g) Colour and markings.

5. Once judged for scale and workmanship the model must not be altered in any way before flight.

6. All models **must fly** for inclusion in the contest.

7. Models may be flown in either or both Speed or Aerobatic classifications.

8. Points awarded for Aerobatic flying will be made using the standard Aerobatic Schedule, half the points so gained being added to the Scale/Workmanship total, maximum gross total thus being 427½ points.

9. Points awarded for Speed flying will comprise one point for each mile per hour recorded, this figure being added to the Scale/Workmanship total.



## APPENDIX VII

## F.A.I. RULES FOR CONTROL LINE SPEED RECORDS, 1949

**Speed records in a circular course**

1. Two types of speed records in a circular course are recognised :—
    - Records for machines driven by mechanical motors.
    - Records for machines driven by reaction motors.
  2. In the case of machines driven by mechanical motors—and solely for records in a circular course—three classes are instituted according to cylinder capacity.
    - (i) from 0.01 c.c. to 2.50 c.c.
    - (ii) from 2.51 c.c. to 5.00 c.c.
    - (iii) from 5.01 c.c. to 10.00 c.c.
  3. In the case of machines driven by reaction motors the following rules apply :—
    - Maximum weight of the bare reaction motor : 500 grammes.
    - Minimum weight of the aircraft in flying order, complete with fuel, four times the weight of the bare reaction motor.
  4. Either hand control or tethering to a pylon will be permitted in speed records in a circular course.
  5. In the case of machines controlled by hand, the wrist of the competing modeller, must during the duration of the flight submitted as a record, rest on a central support terminating in a fork and pivoted on a rigid mast.
  6. The speed will be timed over a minimum distance of 1 kilometre.
  7. Before timing commences the modeller will be permitted a sufficient number of laps to allow the machine to attain its full speed.
  8. The radius of the flight circle is left to the choice of the modeller with the following minimum radii :—
    - Class I—(Cylinder capacity 0.01 to 2.5 c.c.) 11 metres—37 cms.  
14 circuits to the kilometre.
    - Class II—(Cylinder capacity 2.51 c.c. to 5.00 c.c.) 13 metres—27 cms.  
12 circuits per kilometre.
    - Class III—Cylinder capacity 5.01 c.c. to 10.00 c.c.) 15 metres—92 cms.  
10 circuits per kilometre.
- It is suggested in order to facilitate timing to adopt the above radii or the larger radius of 19 metres 99 cms., giving 8 circuits to the kilometre or 26 metres 53 cms. giving 6 circuits to the kilometre.
9. The length of the line shall be measured from the axis of the supporting mast or tethering pylon to the axis of the propeller or reaction motor.
  10. In the case when two propellers or two reaction motors with their axes parallel are employed, the axis of symmetry will be taken as the datum line.
  11. During the duration of the flight submitted as a record, the machine must always remain above the horizontal plane passing through the central point of attachment.
  12. A speed record in a circular course cannot be beaten except by a flight exceeding the existing record by 10 kilometres per hour.

## APPENDIX "VIII"

### ANTI-WHIP YOKE PYLON

#### SUGGESTED ANTI-WHIP YOKE PYLON

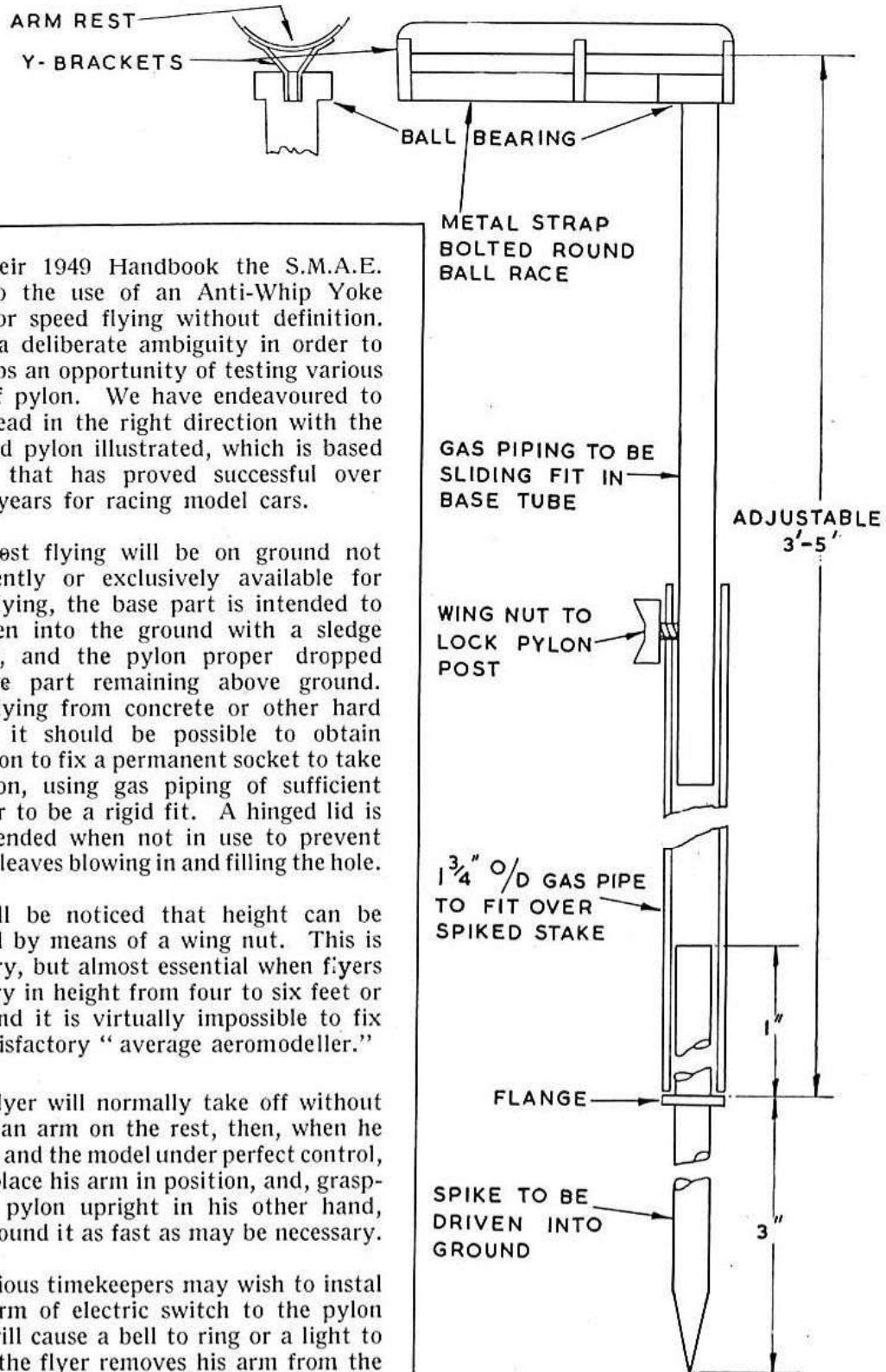

In their 1949 Handbook the S.M.A.E. refers to the use of an Anti-Whip Yoke Pylon for speed flying without definition. This is a deliberate ambiguity in order to give clubs an opportunity of testing various forms of pylon. We have endeavoured to give a lead in the right direction with the suggested pylon illustrated, which is based on one that has proved successful over several years for racing model cars.

As most flying will be on ground not permanently or exclusively available for model flying, the base part is intended to be driven into the ground with a sledge hammer, and the pylon proper dropped over the part remaining above ground. When flying from concrete or other hard surface, it should be possible to obtain permission to fix a permanent socket to take the pylon, using gas piping of sufficient diameter to be a rigid fit. A hinged lid is recommended when not in use to prevent dirt and leaves blowing in and filling the hole.

It will be noticed that height can be adjusted by means of a wing nut. This is no luxury, but almost essential when flyers may vary in height from four to six feet or more, and it is virtually impossible to fix on a satisfactory "average aeromodeller."

The flyer will normally take off without putting an arm on the rest, then, when he is ready, and the model under perfect control, he will place his arm in position, and, grasping the pylon upright in his other hand, gyrate round it as fast as may be necessary.

Ingenious timekeepers may wish to instal some form of electric switch to the pylon which will cause a bell to ring or a light to flash if the flyer removes his arm from the rest. With a spring loaded arm this should not be difficult.

## APPENDIX IX

## TYPICAL COMMERCIAL KITS

Following have been submitted to *Aeromodeller* staff for test and inspection and their published gradings (which apply to kit and materials only and not flying characteristics) are given below.

Aero-modeller Rating	Name	Span in ins.	Type	Maker	Price
*****	CESSNA AIRMASTER	25	Scale ...	Modelair Control Liners ...	17/6
*****	MAGNETTE ...	24	Inter Stunt Trainer	H. J. Nicholls, Ltd. ...	25/-
*****	NANCY ... ..	18	Stunt Trainer	J's Model Centre ... ..	14/6
*****	RADIUS ... ..	22	Sports ...	International Model Aircraft	17/6
*****	RIVAL ... ..	22	Stunt Trainer	Don Models ... ..	—
****	MONARCH ... ..	26½	Sport Speed	Worcraft Products ... ..	17/6
****	NIEUPORT 17C ... ..	20½	Spt. Scale Biplane	Modelair Control Liners ...	19/6
****	PHANTOM ... ..	21	Sport Trainer	Keil ... ..	18/6
****	SABRE ... ..	18	Adv. Trainer	Halfax ... ..	16/6
****	SPEEDEE ... ..	24	Sports ...	Model Aircraft (B'mouth)	17/6
****	STUNTER ... ..	24	Spts. Biplane	Ditto ditto	19/6
***	COPPERHEAD ... ..	32	Sports ...	Astral ... ..	23/6
***	GOBLIN ... ..	24	Sport/Speed	Shaws M.A. Supplies ... ..	15/-
***	MARTINET ... ..	36	CL/FF Goat	Model Aircraft (B'mouth)	21/-
***	MEW GULL ... ..	24	Semiscale ...	Modelair Control Liners ...	19/6
***	NIPPER ... ..	17	Trainer ...	Model Aircraft (B'mouth)	9/6
**	TRAINER ... ..	32	Sport Trainer	Halfax ... ..	20/-
*	HALL RACER ... ..	30	Scale Gull Wing	Astral ... ..	84/-
*	ORBIT ... ..	17	Speed ...	Law and Sons ... ..	18/6

Following have either not been submitted for test or are at present awaiting test by *Aeromodeller* staff and no comment is therefore made. (Listed Alphabetically.)

Name	Span in ins.	Type	Maker	Price
ANITA ... ..	30	Flying Wing ...	J's Model Centre ... ..	19/6
FLAPJACK ... ..	11	All Wing/Saucer	Astral ... ..	—
FLYING WING ... ..	30	Sports ... ..	Skyleada ... ..	25/-
GOSHAWK ... ..	45	Sports ... ..	Model Aircraft (Bournemouth)	79/6
HORNET ... ..	28	Adv. Trainer Speed	Kiel ... ..	45/-
KAN-DOO ... ..	29	Stunt Winner ...	Kandoo Products ... ..	25/-
MAMBA ... ..	28	Stunt ... ..	Powakits... ..	15/6
PHANTOM MITE ... ..	16	Trainer ... ..	Keil ... ..	11/6
PLAYBOY ... ..	30	Inter. Stunt ...	Precision ... ..	17/6
PUSHER PUP ... ..	18	Twin Boom Sports	Don Models ... ..	19/6
RINGMASTER III ... ..	23½	Stunt Biplane ...	Normans ... ..	25/-
SCOUT BIPLANE ... ..	20	Trainer Biplane	Keil ... ..	22/6
SEA FURY X ... ..	25½	Scale Stunt ...	Model Aircraft (Bournemouth)	22/6
SHUFTI ... ..	28	"Flatfish" Stunt	Astral ... ..	10/6
SILVER RAY... ..	27	Inter. Stunt ...	Model and Air Sports ... ..	22/6
STUNTMASER ... ..	30	"Flatfish" Stunt	Keil ... ..	19/6
SUPALUPA ... ..	28½	Stunt Sidewinder	Aeromodels ... ..	25/-
THUNDERBIRD ... ..	29	Semiscale Stunt	Skyleada ... ..	22/6
TIGER MOTH ... ..	30	Scale ... ..	Royles ... ..	21/-
VANDIVER ... ..	26	Stunt ... ..	International Model Aircraft ...	13/6

Note.—These lists do not claim to cover more than some of the more popular kits. These are being added to month by month.

# LOUIS A. HEATH

## Mail Order Specialist

All Control Line Necessities for the Enthusiast

KITS		ENGINES	
Keil Kraft—		Foursome	
Phantom Mite		1.2c.c.	£2.12.6
16in.	11/6	"Mills"	
Phantom 21in.	18/6	1.3c.c.	£4.15.0
Scout Bi-		2.4 c.c.	£5.17.6
plane 20in.	£1.2.6	E.D.—	
Stuntmaster	19/6	2c.c.	£4. 4.0
		2c.c. Comp	
		Special	£4.17.6
<b>Accessories</b>		Mk. III	
Airscrews from	3/3	2.49c.c.	£5.10.0
"BAT" Stunt Tanks,		"Bee"	£2. 5.0
5/- — 7/6 ea.		Nordec—	
Keil Kraft Glo Plugs,		10c.c.	
6/- ea.		Petrol	£12.10.0
All kinds of Spinners		10c.c. Glo	
from 4/- ea.		Plug	£12. 0.0
Spark Plugs —		Spares for all Engines	
Spanners — Handles		Listed above	
Laystrate Wire			
100ft. 6/- — 70ft. 4/3			

Purchase Tax extra where applicable  
Send 1d. Stamp for Complete Lists.  
Please add Postage for Orders under 20/-

**114, Ditchling Road**  
**BRIGHTON, SUSSEX**

## "UP" is still UP!

though the model is inverted  
—if you stunt with the NEW

## ELMIC "ROTALINE"

The control line handle which makes child's play of inverted flying!

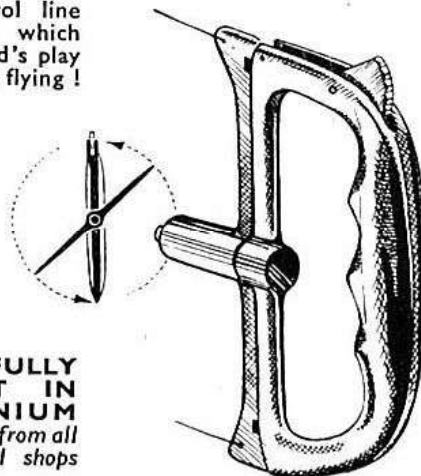

BEAUTIFULLY  
DIE-CAST IN  
ALUMINIUM  
Obtainable from all  
good model shops

A product of **SCORPION MOTORS**

Wholesale distributors:  
E. KEIL & CO., LIMITED, LONDON, E.2

## "APEX"

### Stunt Control Line Airscrews

Material used : Beech Hardwood

Finish : Clear Lacquer

Diam.	Pitch
7 ins.	4 ins. 6 ins. 8 ins.
8 ins.	4 ins. 6 ins. 8 ins.
9 ins.	4 ins. 6 ins. 8 ins.

All diameters and pitches one price

2/6 each By post 2/9

Send P.O. to :—

**Southern Model Supplies**

BCM/MODS

London, W.C.1

TRADE ENQUIRIES INVITED

Have you tested the new

## "BRITFIX" BALSA CEMENT?

If not, we shall be pleased to demonstrate the excellent properties of this cement.



Ideal for all power aircraft where strength and adhesion is essential.



Obtainable through most Model Stockists.



Particulars from manufacturers : Large tube 7d.

**THE HUMBER OIL CO., LTD**  
**MARFLEET HULL**

**The RECORD  
HOLDER for  
CONTROLLINE  
FLIGHT**

**E.D. 2 C.C.  
COMPETITION SPECIAL**

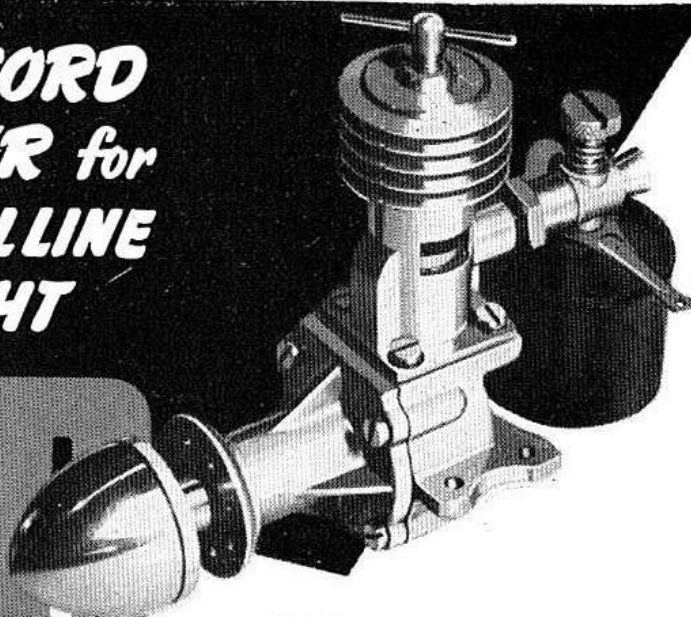

The wonderful little engine which beat craft fitted with engines five times its cubic capacity! Holder of British Speed Record for power units up to 5 c.c. for controlline (89.95 m.p.h.!). Winner of 1948 British Nationals Gold Cup. See the amazing E.D. Competition Special at your Model Shop. Price £3/17/6

**The finest RADIO CONTROL UNIT**

Guaranteed range of control 1,000 yards, but under test and severe conditions craft has been controlled at much longer ranges. Unit comprises two-valve battery operated Transmitter, size 8 in. high, 7 in. wide, 9 $\frac{3}{4}$  in. deep, a three-valve circuit Receiver with single tuning control, and a clockwork Servo. Ask your Model Shop for details.

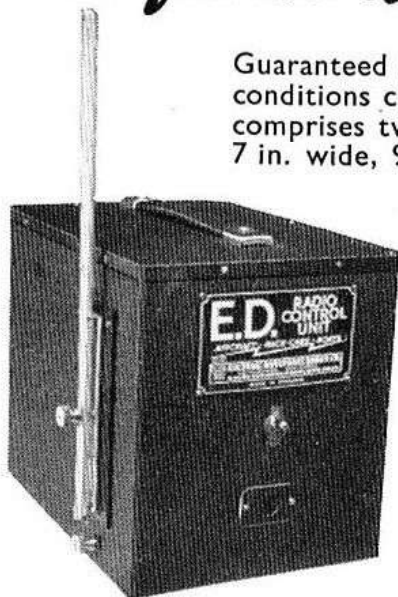

*The Transmitter*

**Complete  
Unit,  
Less  
Batteries  
£14.10.0**

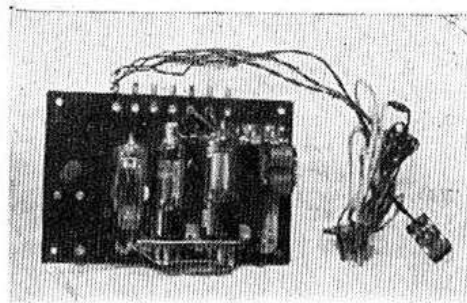

*A view of the Receiver*

**E.D.**

KINGSTON ON THAMES

**ELECTRONIC DEVELOPMENTS (SURREY) LTD.**

DEVELOPMENT ENGINEERS

**1223 18, VILLIERS ROAD, KINGSTON-ON-THAMES, SURREY, ENGLAND.**

HERE IS THE "PREMIER'S" "SILVER RAY"  
CONTROL LINE  
MODEL YOU  
HAVE BEEN  
WAITING FOR!



A new control line kit by  
one of our young Design-  
ers, Ray Silver, D.F.C.

Complete Kit  
**22/6**

For all first-class Control Line Materials : Props,  
Control Line Handles, Wheels, Lines, Tanks,  
Bell-Cranks, Horns, etc., contact—

## MODEL & AIR SPORTS LTD.

37 UPPER STREET, LONDON, N.1 (Can. 4527)  
132 GREEN LANES, PALMERS GREEN, LONDON, N.13 (Palmers Green 3327)  
2a HORNSEY RISE, LONDON, N.19 (Archway 2376)  
THE "PREMIER" LONDON FIRM

## TEKNI-FLO 'HYDULIGNUM'

STUNT WITH EASE WITH BRITAIN'S FINEST  
GAS PROPS.

In the 1948 National Gold Trophy 99% of the  
entrants used TEKNI-FLO PROPS.

Take a tip from the top stunt flyers and use  
TEKNI-FLO PADDLE BLADE STUNT PROPS  
in the following sizes :

8in. dia. x 8in. pitch	...	...	4/6
9in. „ x 8in. „	...	...	5/-
10in. „ x 8in. „	...	...	5/6
11in. „ x 8in. „	...	...	6/-

**FYLDE MODEL CO.**  
165, Highfield Road, Blackpool

*Obtainable from your dealer*

# CONTROL LINE PLANS

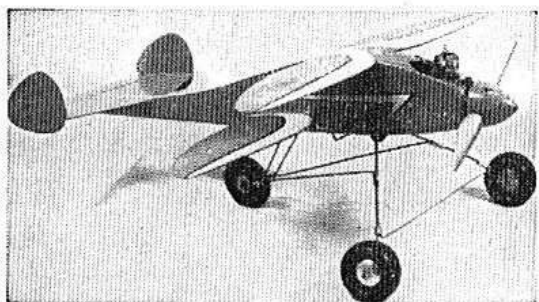

**Tyro Trainer**

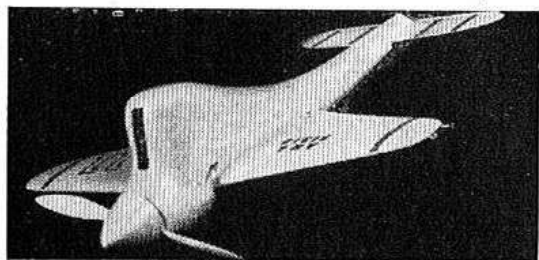

**Speed King**

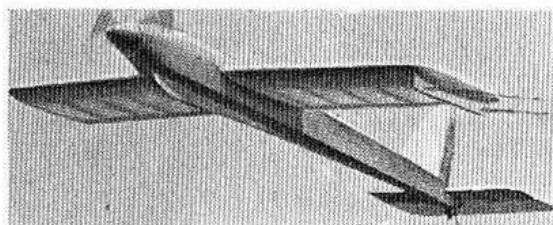

**Crackerjack**

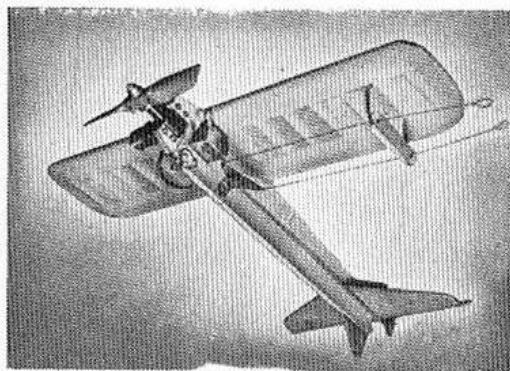

**Cheetah**

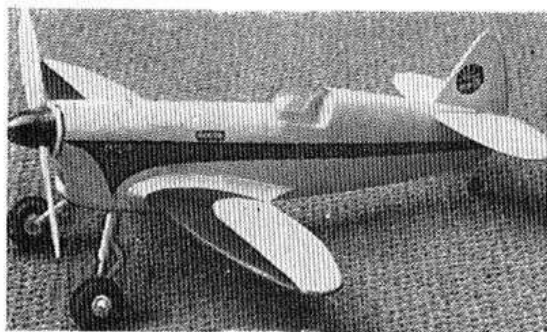

**Candy II**

Send 2½ stamp for our full Flying Plans list containing over 200 proven designs for Power, Rubber, Glider, Scale and Indoor models.

CL/269. **CANDY II.** By F. B. Thomas. A simple sports trainer model suitable for the beginner who requires looks as well as performance. Low elliptic wing, turtle back slabsider. For engines up to 2.5 c.c. diesel, 5 c.c. petrol. 38 in. span. **5/-**

CL/284. **SPEED KING.** By Walter Musciano. Streamlined speed design by U.S. ace, in latest "no-fin" style. Dolly take-off, high performance 100 m.p.h. plus machine. For 6/10 c.c. engines. **3/-** 19 in. span.

CL/295. **TYRO TRAINER.** By Walter Musciano. Unstrutted Biplane speed trainer. Sheet fuselage, solid wings, twin fin tail. Take-off dolly or fixed undercarriage. For 3.5-5 c.c. diesels. **2/-** Speed up to 80 m.p.h. 22½ in. span.

CL/303. **CRACKERJACK.** By Aeromodeller design staff. Midwing sidwinder in the U.S. style, with drop-off undercarriage. Simple to build stunt machine that will go through "the book." **3/-** For 2/3½ c.c. diesel or glowplug. 32 in. span.

CL/307. **FOKKER TRIPE.** By Walter Musciano. Scale "old timer" triplane with a performance as good as its looks. Simple foolproof line-up strutting for wings. For 2/3½ c.c. diesel or glowplug engine. **3/-** 23½ in. span.

CL/313. **CHEETAH.** By E. Wiggall. "Flatfish" sidwinder stunt machine up to all the tricks. Anti-blanketing tail, stout construction, "unbreakable" folding prop. For 1/1.5 c.c. **2/-** diesels. 23 in. span.

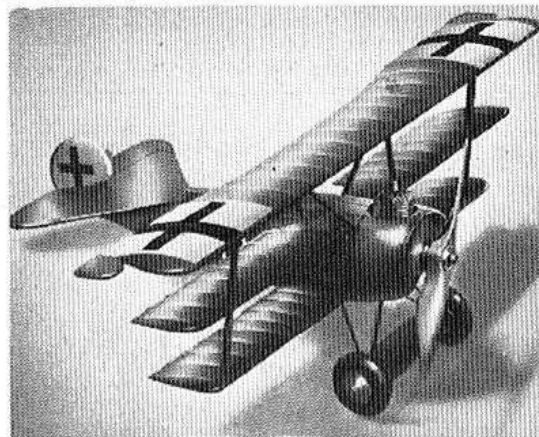

**Fokker Tripe**

"By return" post free postal service, or may be obtained from your local model shop.

**AEROMODELLER PLANS  
SERVICE**

THE AERODROME,  
STANBRIDGE,  
LEIGHTON BUZZARD, BEDS.



## THE 'RIVAL'

22 in. CONTROL LINE  
MODEL

THE KIT THAT  
GIVES YOU VALUE  
FOR CASH

- Strongly Constructed Sheet Fuselage.
- Printed Parts on Best Quality Balsa and Ply.
- Removable Wings.

Solid Rubber Wheels can be supplied 2/- extra.  
'Rival' Plan only 2/3 Post Free

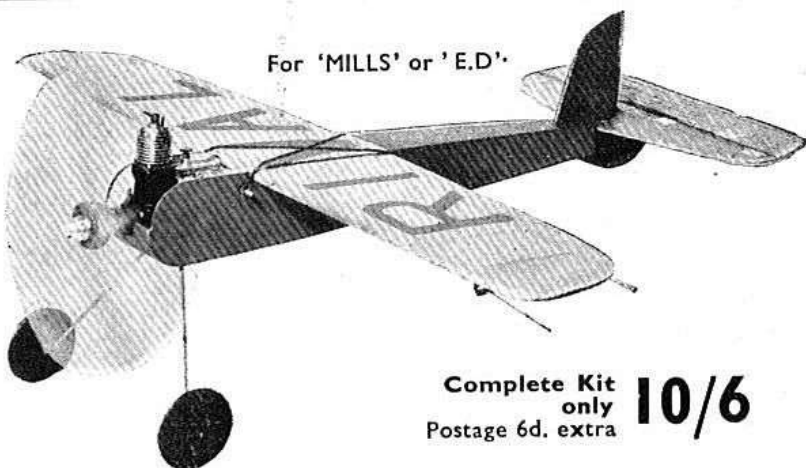

For 'MILLS' or 'E.D.'

Complete Kit only **10/6**  
Postage 6d. extra

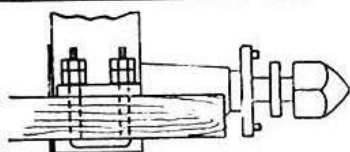

### EASY FIX 'U' BOLTS

Suitable for Mills E.D. Amco, Frog, and E.D. 1 c.c. Engines  
Postage 2½d. PAIR  
State Engine when ordering

Best Quality Plastic Tube  
Small Bore 4d. Large 6d. per ft.  
ALTON VALVE SPOUTS 3/9 each  
Postage on above 2½d.

## The 'NIFTY'

See *Aeromodeller* for Photos

Designed for the Advanced Control-Liner, this Model with E.D. Comp or Rawlings 1.8 has been "through the Book"—in fact, giving full performance in ALL Advanced Stunts. Nifty in Price and Design

Trade Inquiries invited

Obtainable from your local stores, or direct from :—

**DON MODELS**  
65, ATLANTIC ROAD, LONDON, S.W.9

Tel.: BR1xton 3874

26 in. SPAN  
STUNT  
CONTROL LINE

Complete Kit  
(Less wheels)

**12/6**

postage 6d. extra

# Raylite

TEL : 89216

EST 1934

SUPPLIES LTD., 21, ARKWRIGHT ST. NOTTINGHAM

*The best things in "Aero-modelling" are obtainable at the 'Midland's Mail Order House'*

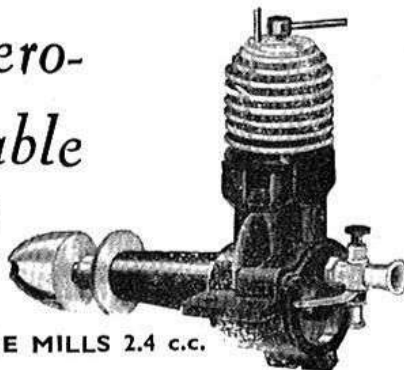

THE MILLS 2.4 c.c.





**1.2.3. PROOFER** forms a transparent film that is fuel-proof, water-proof, weather proof—yet light as a feather.

**One Coat of 1.2.3. PROOFER** encases your model aircraft in a skin which for the average model weighs only between 1/40th and 1/60th ounce.

**1.2.3. PROOFER** is applied with a soft rag like French Polish, and it won't cause the cellulose colours already on your plane to run as you put it on. It dries in 10 minutes. One bottle will proof a surface area of 3,000 square inches—two normal models.

PER BOTTLE **2/3**



**ZOOM** PACKS ENORMOUS DRIVE AND POWER. NEW ENGINES DESERVE IT, OLD ENGINES NEED IT

**ZOOM** is a completely new development in model aero-engine fuels. Scientific tests have shown that the tremendous power and drive produced by this amazing new fuel provides greater static thrust than has ever been known before in a fuel for model diesel aircraft. It gives no trouble because it is chemically right, triple-filtered, and cannot foul tanks, jets or supply tubes.

HALF PINT BOTTLE **2/6**

Distributed to the trade through **Cartwrights Model Supplies, Ltd., 19-21-39, Elystan Street, S.W.3**  
for the manufacturers: **Lincoln Model Supplies, 2, Lumley Avenue, Skegness.**

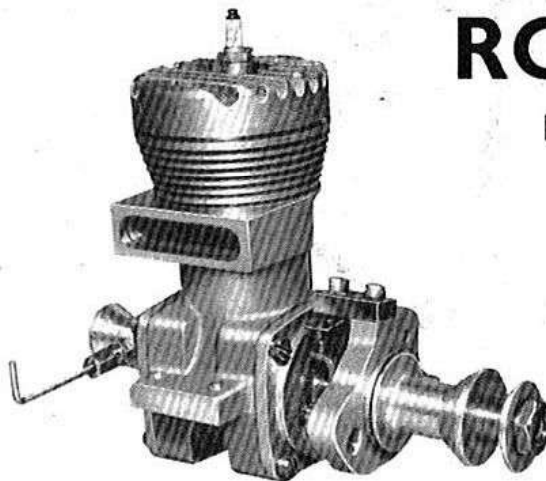

## ROWELL "60"

### HIGH PERFORMANCE RACING ENGINE!!

- Capacity - - 10 c.c.
- Bore - - - -  $\frac{15}{16}$  in.
- Stroke - - - -  $\frac{7}{8}$  in.

The ideal Power Unit for  
Speed Control Line and  
Large Stunt Airplanes

Price - - - **£12.0.0**

(plus Purchase Tax £2/18/6)

Propellor Boss - - - 5/- extra

Sparking Plug - - - 6/- „

Glow Plug model only - **£11.10.0**  
(plus Purchase Tax)

This engine is made to precision limits by highly skilled engineers and is the finest All British racing motor obtainable today

Obtainable through your local Model Shop  
or in case of difficulty direct from:

**Rowell Motors, Ltd., 93, Victoria Rd., Dundee ● Phone 4615**

# BOOKS FOR POWER MODELLERS

## DESIGN AND CONSTRUCTION OF FLYING MODEL AIRCRAFT

Standard reference book on model aeronautics, particularly for the power modeller, by D. A. Russell, M.I.Mech.E. Brief contents: Airfoils. Airfoils and Fuselages for Monoplanes and Biplanes. Drag. Control Surfaces. Aircraft Performance. Airscrew Design. Airscrew Performance. Rubber Motors. Testing Powerdriven Airscrews. Wind Tunnel Testing. Wing Construction. Fuselage Construction. Tail Units. Landing Chassis, Tyres, and Wheels. Mounting of Engines and Accessories. Engine Testing and Timing. Flying Petrol Models. High Speed Petrol Planes. Formulae.

*Cloth bound, gilt blocked, three colour dust jacket. Over 250 illustrations. 256 pages white art paper, size 8½ x 5½ ins.*

**10/6**

## MODEL DIESELS

By D. J. Laidlaw-Dickson. Nearly 15,000 sales. Brief contents: First Light on the Diesel. Engines up to 2½ c.c. Engines over 2½ c.c. Starting, Maintenance and Trouble Finding. Considerations of Design. Diesel Fuels Discussed. Making a 5 c.c. Engine. Timing Devices. Notable Models. Further Uses. Numerous Appendices.

*Cloth and card bound, gilt blocked, three colour dust jacket. Over 100 illustrations. 128 pages white art paper, size 8½ x 5½ ins.*

**7/6**

## PETROL ENGINES

By J. F. P. Forster. Practical book on the subject. Brief contents: General Principles and Review of Types. Methods and Rationale of Engine Mounting. Engine Cowling Considerations. Field Operation and Management. Engine Maintenance. Appendices.

*Cloth bound, gilt blocked, three colour dust jacket. 96 pages, size 8½ x 5½ ins. (Cheap paper covered edition 3/-.)*

**6/-**

*These and many other aircraft books direct from the publishers or from model shops and booksellers.*

# HARBOROUGH

THE AERODROME  
BILLINGTON ROAD, STANBRIDGE  
LEIGHTON BUZZARD, BEDS.



BRITAIN'S FIRST AIR CENTRE

# FLY

 C/L AT EATON BRAY  
GRASS OR CONCRETE  
TAKE-OFF AREAS

CATERING  
FACILITIES  
PARKING  
TOILETS  
MODEL SHOP

Send 2½d. stamp  
for this year's  
programme.

The only aerodrome for model aircraft welcomes control line flyers, who can fly in perfect safety, either from grass or concrete take-offs (70 ft. diameter circle).

Over 70 acres of Aerodrome available for all forms of model flying. Model Shop on the field for fuel, materials, etc. Catering facilities from an ice cream to a hot meal.

Camping sites, with water, etc., for those wishing to make a longer stay. Special instructional aeromodelling camps under cover with private dining room, dormitory, separate toilets, showers, and model workshop.

EATON BRAY MODEL SPORTSDROME, LTD.  
THE AERODROME, BILLINGTON ROAD,  
STANBRIDGE, Nr. LEIGHTON BUZZARD, BEDS.