



**A PERCIVAL MARSHALL  
PRODUCTION**

*Model*  
**GLOW PLUG  
ENGINES**

by C. E. BOWDEN



**3/6**

**PERCIVAL MARSHALL**

MM

MODEL GLOW PLUG ENGINES

MODEL  
GLOW PLUG ENGINES

*by*

Lt. Col. C. E. Bowden  
A.I.Mech.E.



LONDON  
PERCIVAL MARSHALL & CO., LTD.

First published 1949

Other books by the author

*Diesel Model Engines*  
*Petrol Engined Model Aircraft*  
*Model Yacht Construction and Sailing*  
*Model Jet Reaction Engines*

Published by Percival Marshall & Co., Ltd., 23 Great Queen Street,  
London, W.C.2, and printed by Robert Stockwell Ltd., 5-7 Baden Place,  
London, S.E.1

## FOREWORD

Glow plug ignition has taken America by storm. In one short year almost every model engine manufacturer turned to glow plug ignition. Once the slide began it was difficult to find in the advertisement columns of American magazines any manufacturer who did not offer at least one of his engines with glow plug ignition.

Glow plug ignition featured prominently in the speed events for model aeroplane boat and car. In this country it set up a new record for hydroplanes. All this took place whilst we in Britain developed our diesels to perhaps the highest standard in the world.

The glow plug engine has certain similar advantages to the diesel, such as the elimination of the weight of coil ignition to be carried by the model. On the other hand the glow plug motor has entirely different speed characteristics which should be understood by those using model internal combustion engines. The glow plug motor is undoubtedly becoming the engine of the moment in Britain, and I predict it will enjoy a great popularity when its advantages and disadvantages, too, are thoroughly understood.

It is to that end that I have written this short book in the hope that I may put fellow model enthusiasts into the glow plug ignition picture, and also indicate the sort of model in which the glow plug engine gives of its best.

I want to thank the following publications for kindly allowing me to make use of certain material. *Practical Mechanics*, *The Model Engineer*, *Model Aircraft*, *The Aero-modeller*.

C. E. BOWDEN.

Bournemouth, January, 1949.

## CONTENTS

### CHAPTER ONE Page 1

#### The History of Glow Plug Ignition and How It Works.

High speed characteristics, and compression ratio of the glow plug engine—The history of hot point or glow plug ignition—The petrol motor and the glow plug engine compared—The two-stroke cycle of operation—Glow plugs and their construction—How glow plug ignition starts and works the engine—The carburetter—Tanks and fuel flow—The starter battery—Starting procedure—Essentials of hot point ignition—Advantages of glow plug ignition.

### CHAPTER TWO Page 31

#### The Fuel for Glow Plug Engines.

The requirements—Alcohol—Nitro methane—Additives—Commercial fuel blends—Home mixtures—An American mixture—Lubrication—Methanol damages tanks made of celluloid—Protective finishes—A simple way to carry the glow plug fuel—Castor oil lubricant keeps rubber bands in good order.

### CHAPTER THREE Page 39

#### Glow Plug Engines.

American manufacturers—The OHLSSON—Large porting—FROG 160 RED GLOW—A new standard of small stunt machine—The 10 c.c. engine—The NORDEC—ARDEN engines—Ball races—360 degree exhaust and intake porting—A ball and socket bearing—The E.D. "Induction Boost"—The WILDCAT—The ROWELL 60—A racing design—The MAJESCO—The ATWOOD CHAMPION and GLOW DEVIL—The TRIUMPH 49—The DOOLING 61—A special head—Experimental work.

### CHAPTER FOUR Page 58

#### Operational Hints for Glow Plug Engines.

High revolutions are important—Fuel tank design for high speed, and centrifugal force considerations—The racing DOOLING tank—Propellers for glow plug engines—A propeller table—Swinging and positioning the propeller—Converting the existing "petrol" engine to glow plug ignition—Mounting the glow plug engine—Do not dismantle your engine unnecessarily—How to stop the glow plug engine—Mechanical starting for large capacity engines—Running in and testing engines—Simplicity is a strong feature—Experimental models—Water craft—Fault finding chart.

## CHAPTER ONE

### *The History of Glow Plug Ignition and How It Works.*

GLOW PLUG ignition is a new adaptation of one of the earliest forms of ignition for internal combustion engines. It was used in the very early days of motoring but died out as it was superseded by timed spark ignition which proved more suitable for the varying speeds required for road work. As the reader will see on reading this book, the glow plug motor must run at high R.P.M. due to the form of ignition. A road vehicle demands an engine with pulling powers at low revolutions as well as high speed. A model engine, for most purposes, runs at high speed, and therefore glow plug ignition is highly satisfactory. There are exceptions to this rule which we will discuss shortly.

This high speed running is most vital to successful operation of the glow plug motor and affects the type of model in which the engine is installed. It is a point that requires very careful consideration, for when an engine produces its power at high revolutions, then such components as propellers, or gear ratios on a car, must obviously be arranged to suit the high speed characteristics of the engine. If this is not done the performance is killed.

The glow plug motor has two factors in common with the model diesel. The engine carries no electrical batteries or other equipment in the air, on the water, or in a car. The advantages of this fact are obviously great. Models can be built lighter and it also opens up the way for smaller and more portable models. A light wing loading or a light water loading is of great benefit when stability in the air or on the water is being sought.

The second similarity between glow plug motor and diesel is a higher compression ratio than is used in a petrol

engine, although the glow plug motor does not have such a high compression ratio as the diesel. For instance, the average diesel has a compression ratio of approximately 16 to 1. A glow plug engine is satisfied with around 8 to 1 and upwards, whilst the petrol motor runs very well from about 5 to 1, to 6 or 7 to 1. "Compression ratio" means that an engine compresses a charge of gas in its cylinder, by squeezing that charge into a space, shall we say, six times smaller between piston and cylinder head as the piston rises in the cylinder on the compression stroke. Thus, if a given volume of gas is taken into the cylinder, it can be squeezed into any range of compression ratio by altering the distance between the top of the piston (at the top of its stroke) and the top of the cylinder head. If the reader will look at Fig. 2 he will see a cut-away view of the well-known "Ohlsson" glow plug engine which shows the piston in the cylinder. Because the piston is attached to the rotating crankshaft, which is reminiscent of the crank of a pedal cycle, the piston travels up and down in the cylinder. In the "two-stroke" engine, the piston travels up and compresses the gas which has been transferred from the crankcase to the cylinder, and when near the top of its stroke, termed top dead centre or T.D.C. for short, the compressed gases are fired. The resulting expansion of gases, generally termed "explosion" drives down the piston on its power stroke in the same manner that you or I push the pedal down on the power stroke when we are cycling. As the piston goes down the cylinder, it opens an exhaust port. The burnt gases rush out from this port into the atmosphere. This sudden rush of expanded gas causes the exhaust noise that excites the enthusiastic modeller but often upsets the general public's state of peace.

If the modeller is not sure of how the internal combustion motor functions he should study the description and sequence of the "two-stroke" engine given below, for almost all model engines are "two-strokes". A few

FIG. 1. SIMPLIFICATION OF IGNITION  
FOR  
MODEL INTERNAL COMBUSTION ENGINES

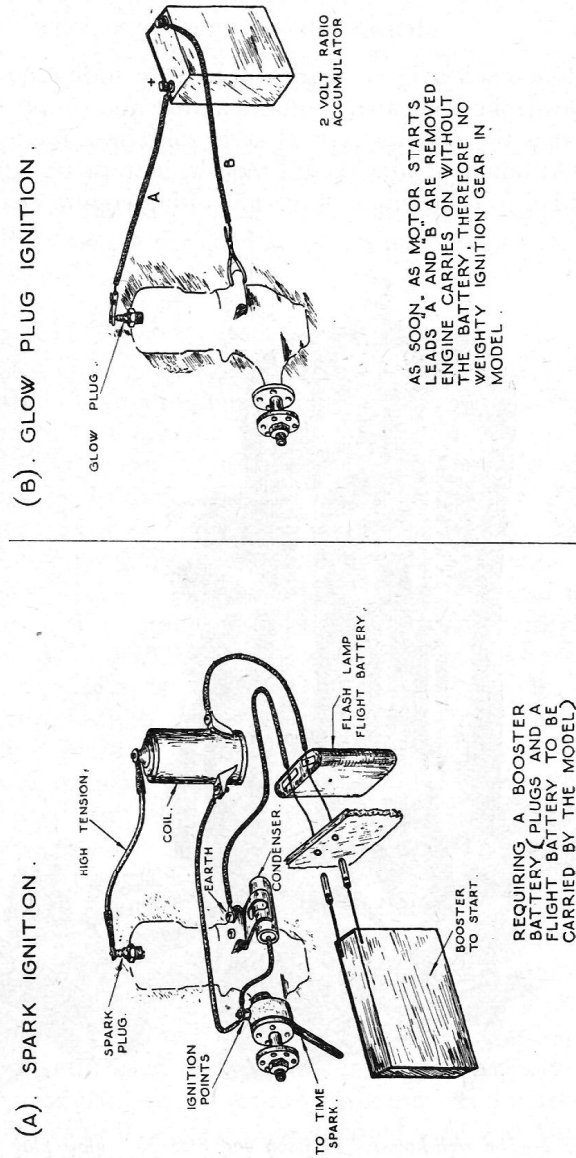
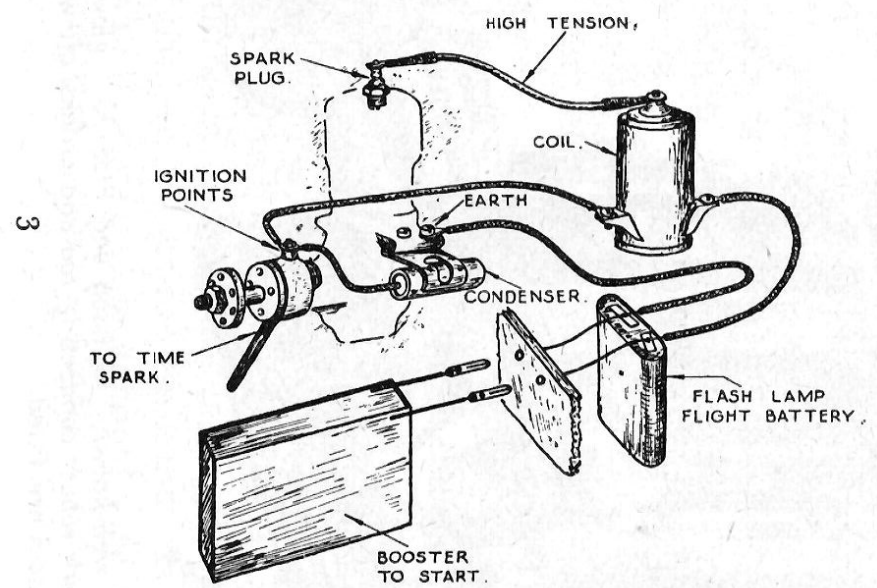

FIG. I. SIMPLIFICATION OF IGNITION  
FOR  
MODEL INTERNAL COMBUSTION ENGINES.

(A). SPARK IGNITION.



REQUIRING A BOOSTER BATTERY (PLUGS AND A FLIGHT BATTERY TO BE CARRIED BY THE MODEL)

(B). GLOW PLUG IGNITION.

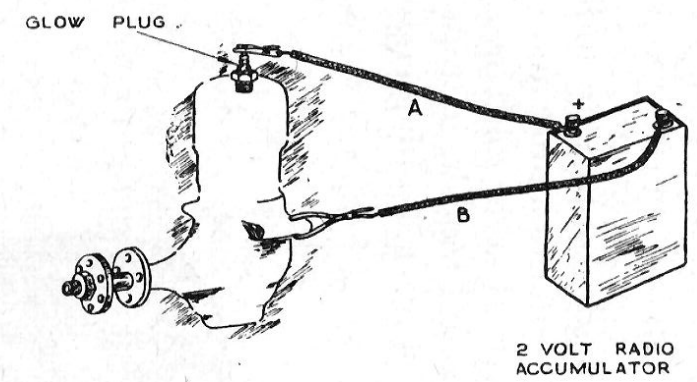

AS SOON AS MOTOR STARTS LEADS "A" AND "B" ARE REMOVED. ENGINE CARRIES ON WITHOUT THE BATTERY, THEREFORE NO WEIGHTY IGNITION GEAR IN MODEL.

“four-strokes” are made by private individuals, but the two-stroke is cheaper to manufacture and simple to operate, and is the normal type that is sold in a model shop.

Although it may sound foolish, it must be admitted the added staccato noise of the glow plug engine’s exhaust note

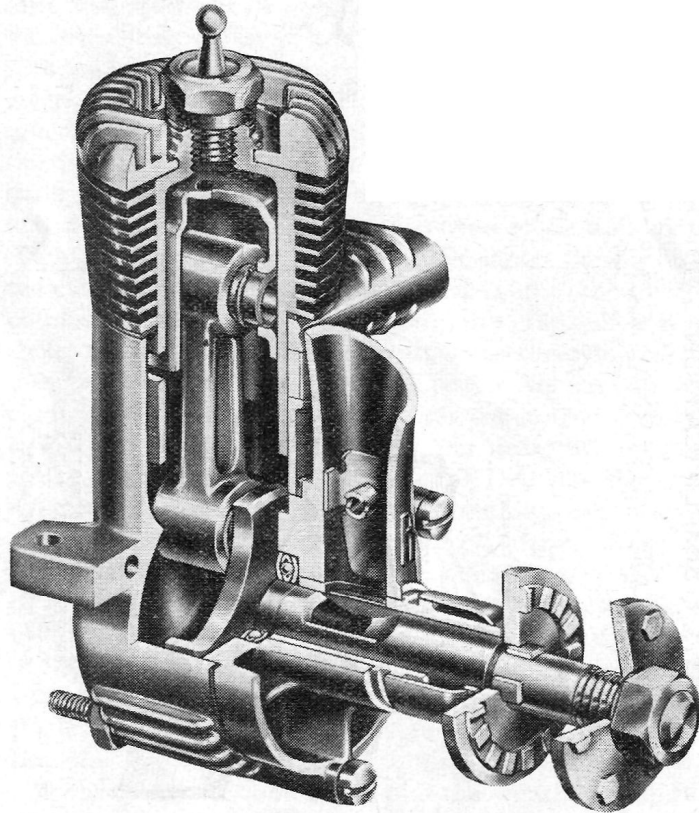

Fig. 2—The well-known “Ohlsson and Rice 23” glow plug motor shown in section with robust connecting rod and crankshaft with rotary induction port. Ball races are fitted.

over that of a diesel, is exciting and *sounds* more powerful. It is therefore often called an advantage of the glow plug engine!

In Fig. 1 the reader will be able to understand how much more simple the glow plug engine is when compared to the older and more usual spark ignition motor, although the actual engine, except for its higher compression ratio, is fundamentally the same.

#### *The History of Hot Point or Glow Plug Ignition.*

Glow plug ignition is a general term for the specialised commercial names made popular by firms of model engine manufacturers. Thus, the American H & H motor introduced what seems to have been the first commercially available motor on these lines. This was called the “Hot Point Ignition H & H” motor. This engine was designed and tested before the last war and went into production in quantity early in 1946. The capacity was 7.4 c.c. and the weight 8 oz. The motor to-day has a terminal on the cylinder head, and in this respect is unlike all its competitors who place a detachable glow plug in the cylinder head. A three-volt battery is connected to the terminal and “earth” is via a resistance wire which is used to cut down voltage from new cells and obviate any burning out of the starting element. The latest H. & H. 45 engine claims to be “the only engine that gives you a fully exposed platinum coil for maximum efficiency in starting and operation.”

Mr. Arden, the maker of the famous Arden motors renowned for their terrific performance for small capacity, and also for clean design, was the first to produce a glow plug in quantities under the trade name “glo-plug”. Many manufacturers at first used his plugs in their motors, some later producing their own for the commercial market. In the early days Mr. Arden experimented with very small glow plug motors, and I am indebted to him for kindly



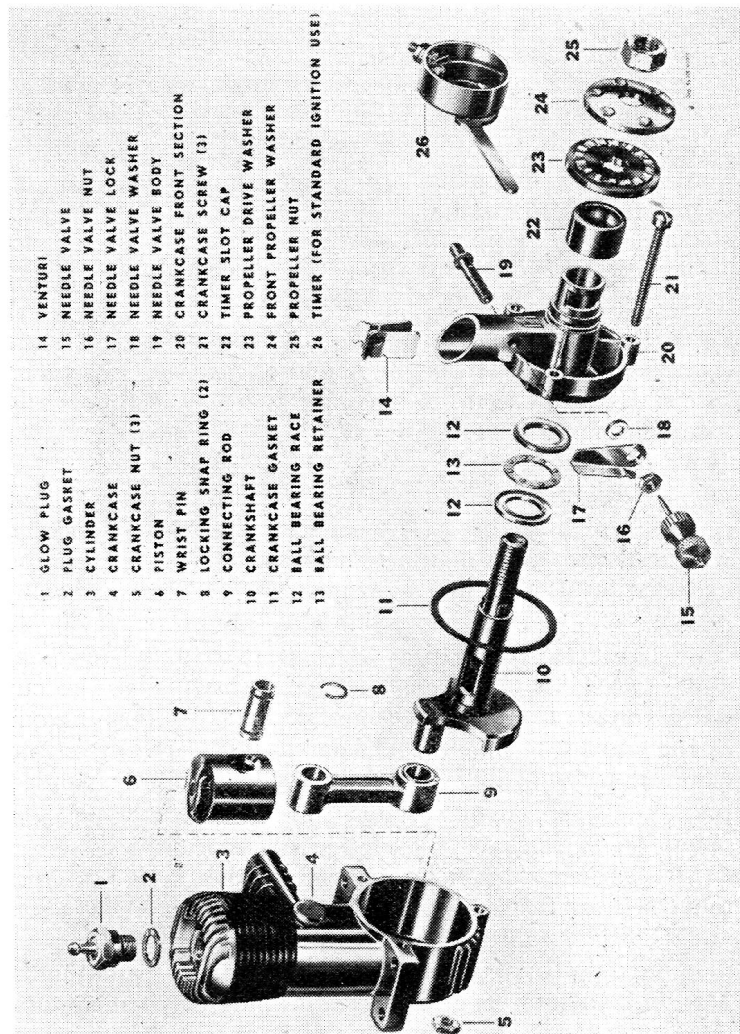

sending me some photographs and particulars of these engines which I have included below, as they are of historical interest and were the forerunners of the general line of glow plug motor to-day. They also prove how very small models can be produced when using glow plug power. At the same time, Mr. Arden sent me one of his ball bearing standard Arden engines fitted with glow plug. The Arden engine is, of course, well known all over the world for its wonderful performance for size, and the inspiring exhaust note in keeping with the performance.

The best power is produced at the very high r.p.m. of 10,000 under load of air propeller. Twenty thousand r.p.m. are possible with flywheel running light, which gives one some idea of the outstanding performance of these little motors. As a result of Mr. Arden's kindness I was one of the first in this country to sample the advantages of glow plug ignition. Since then I have had most of the good British development engines in this class through my hands, as well as converting innumerable petrol motors to glow plug ignition.

Following the success of these early engines, well-known American manufacturers produced suitable motors or adapted their petrol engines to use glow plug ignition. All these manufacturers, including the British who followed the American lead, have used varying trade names to describe glow plug ignition, which in effect means a plug that glows continuously hot in the cylinder head whilst the engine is running. It must be understood that it is in no way a timed spark plug engine. A glow plug motor does not therefore have a contact breaker to time the spark as the petrol engine does, for there is no spark, and where a petrol motor has been converted to glow plug ignition the contact breaker gear is disconnected or better removed. There is a

OPPOSITE. Fig. 3—This exploded view of the "Ohlsson 23" glow plug motor shows the component parts of the engine.

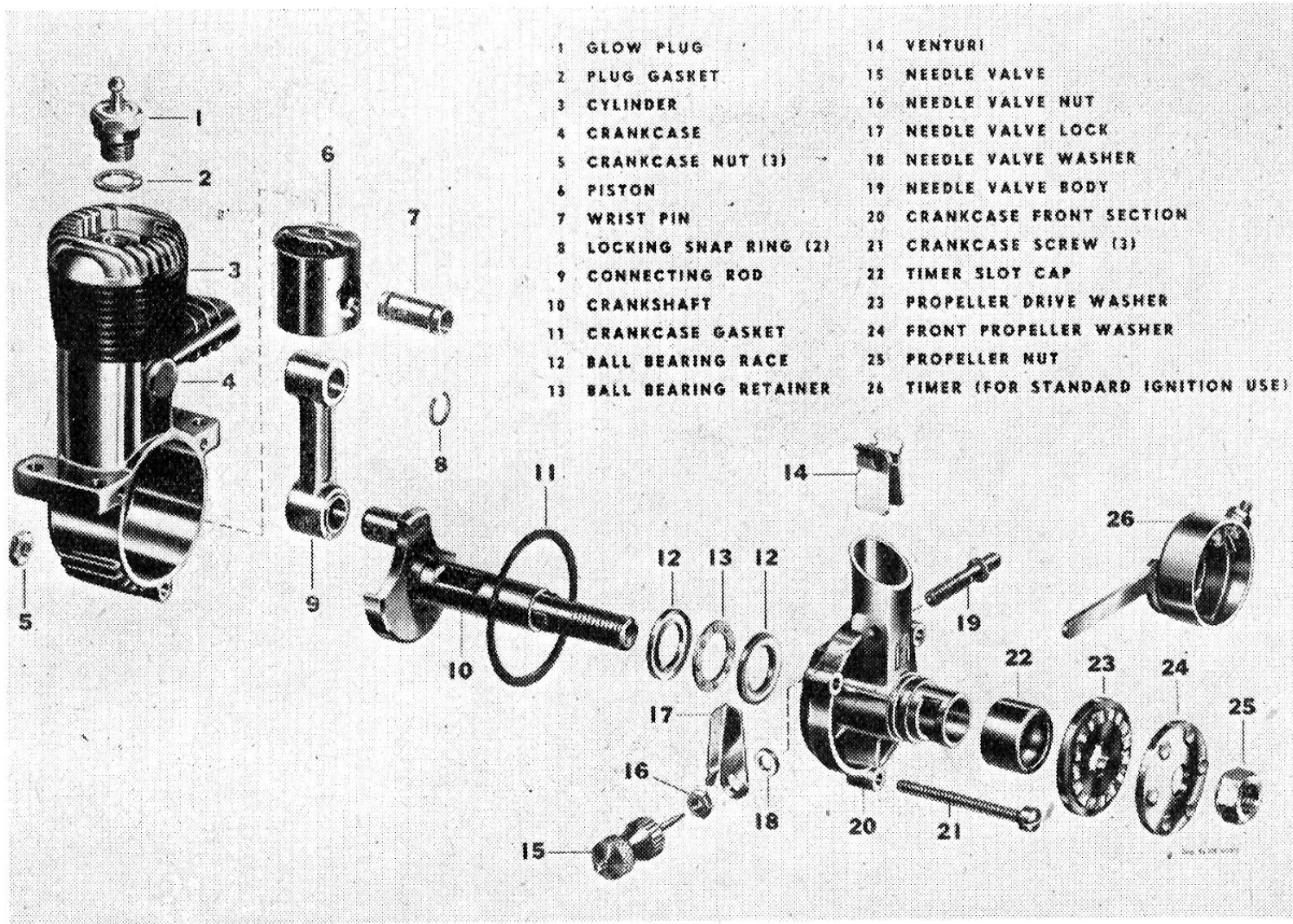

certain amount of friction and energy required to drive a contact breaker. See Fig. 1.

*The Petrol Motor and the Glow Plug Engine compared.*

Perhaps it is best to explain to the novice that normal spark plug ignition has a coil to create the high voltage spark and this spark is mechanically timed to take place when the piston is at a chosen point in the cylinder near the top of the stroke, i.e., T.D.C. Thus, if the spark is timed to occur early, just before the piston reaches the top of its stroke, the motor will run fast. If the spark occurs later the motor can be made to run slowly. The spark timing can be varied by moving a control lever.

The glow plug on the other hand is always glowing whilst the engine is in operation, and as we shall see shortly, the

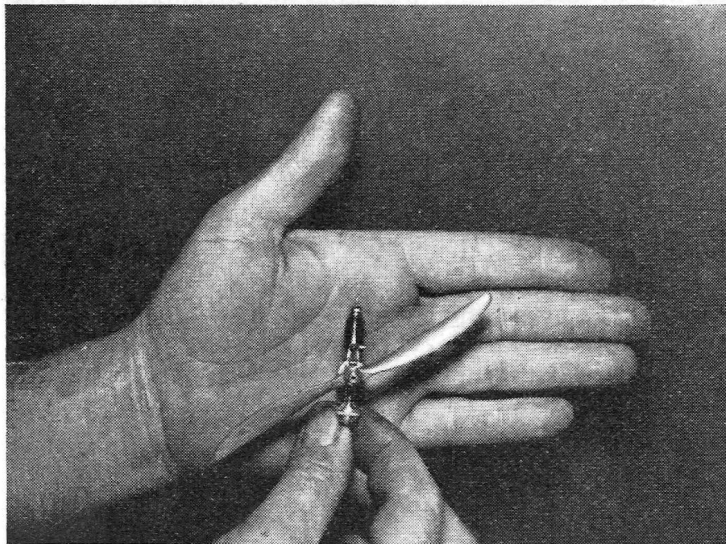

Fig. 4—Mr. Arden, the American enthusiast and manufacturer, made one of the earliest "Glo-plug" motors. The engine shown weighs 87 grains and has over 200 hours running to its credit, a bore of 0.220" and a stroke of 0.220".

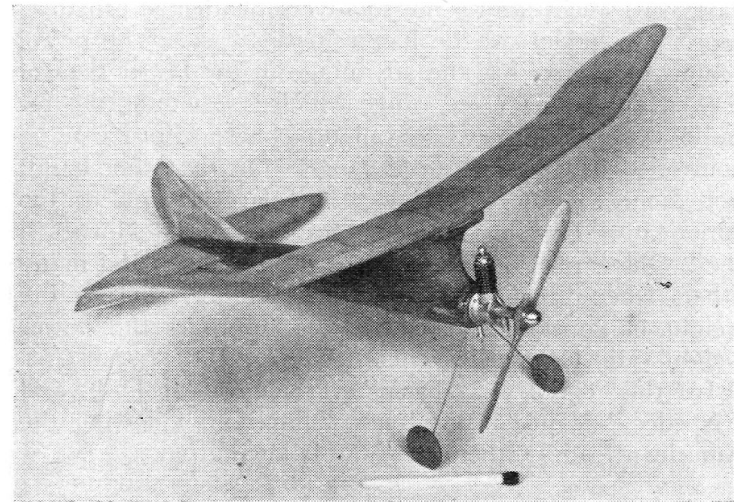

Fig. 5—Surely one of the smallest free flight glow plug models. The span is 12" and total weight, ready to fly, 208 grains. The engine has a bore of 0.187" and stroke 0.220". Built by Mr. Arden.

ignition of the gas is fixed except for a certain latitude of adjustment through using varying compression ratios and special fuels. This adjustment must remain fixed and *must be of an early nature which gives high speed running.*

The Americans found that generally speaking, glow plug ignition gave a greater performance, which was enhanced through not having to carry the weight of coil, condenser and battery. We are finding the same in this country.

The weight of coil, battery, etc., of the petrol motor is out of all proportion to the weight of a small petrol engine. Thus, the ignition gear of the petrol engine is often considerably more than the whole engine. For instance, a baby engine may weigh 2 oz., and the coil will weigh as much as the engine, namely, 2 oz., the condenser and the wiring another 1½ oz., and the flight battery from 3 to 4½ oz. The larger petrol motor can produce the power to

carry this weight and is not so adversely affected ; furthermore, the model can be larger in this case. The petrol motor, of course, has the advantage in the larger sizes of having a variable speed range which is advantageous for radio controlled model aeroplanes where climb can be controlled by variable speed range. On the other hand, hot racing engines of 10 c.c. and larger, such as the American "Dooling", the "McCoy", the "Hornet", the "Ohlsson 60", the "Atwood Champion", and many others when fitted with glow plug ignition cut out the weight of ignition gear which also improves the power weight ratio for speed events.

In this country, "Frog", "Keil", "E.D.", and "Nordec" leapt to this "new" ignition, following the American lead. Others are now following on.

#### *The Two-stroke Cycle of Operation.*

It is important to understand the cycle of operations of a two-stroke engine in general, before one discusses the operation of a glow plug engine in detail. Fig. 6 will serve to follow the working principle of the two-stroke.

The two-stroke is very simple in operation, although it may be a little confusing to grasp.

Every time the crank makes a complete revolution the piston travels once down the cylinder and once up the cylinder.

*The piston therefore completes two strokes for every revolution of the crank, and there is an explosion on every second stroke. That is why the engine is called a "two-stroke".*

The engine is kept going during the strokes, when there is no explosion, by the momentum of a flywheel or a propeller. For aeroplane work we use a propeller instead of a flywheel, and this propeller should be sufficiently

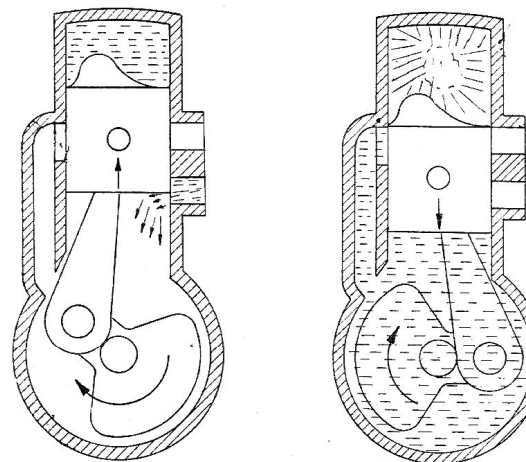

PISTON RISES SUCKS GAS INTO CRANKCASE COMPRESSES GAS IN CYLINDER

COMPRESSED GAS IGNITED AND EXPLODES DRIVES PISTON DOWN WHICH COMPRESSES GAS IN CRANKCASE

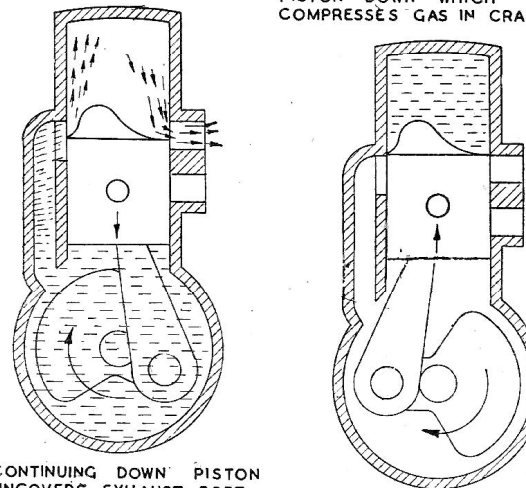

CONTINUING DOWN PISTON UNCOVERS EXHAUST PORT RELEASES BURNT GAS TRANSFER PORT OPENS CRANKCASE GAS RUSHES INTO CYLINDER

PISTON RISES COMPRESSES GAS AND RESTARTS CYCLE OF OPERATIONS

N.B. THE DEFLECTOR HUMP ON TOP OF THE PISTON IS NOT USUALLY FITTED TO MODEL DIESELS

OPPOSITE. Fig. 6—The cycle of operation of a two-stroke engine.

heavy to act in lieu allied to the air resistance of the propeller.

The two stroke operates as follows :—

- (1) There is one power stroke to every revolution of the crank shaft, or two strokes of the piston.
- (2) The piston ascends the cylinder, causing a suction in the crankcase. (There must be no air leaks down bearings or from other sources.)
- (3) As the piston nearly reaches the top of its stroke, an inlet port in the cylinder lower wall is uncovered by the bottom of the piston. A charge of gas is then sucked into the crankcase from the carburetter.
- (4) The piston closes this port upon commencing its descent, and the charge in the crankcase is then compressed.
- (5) As the piston nears the bottom of its stroke, with compression of gases at their maximum, the top of the piston uncovers a transfer port in the cylinder wall cut a little above the inlet port. This transfer port is connected to the crankcase, and the compressed charge now escapes to the combustion chamber in the cylinder head.
- (6) A further ascent of the piston closes the transfer port and compresses the charge in the cylinder head, ready for ignition and the subsequent "explosion".
- (7) In a spark ignition engine the spark now occurs around the top of the stroke. In the glow plug motor there is the glowing element which fires the charge. The piston is driven down.
- (8) As the piston goes down it opens a large exhaust port cut in the cylinder wall, and the burnt gases escape by reason of their own velocity, reducing the pressure in the combustion chamber to approximately that of atmosphere.
- (9) The transfer port is again uncovered almost at the bottom of the stroke. See paragraph 4 above.

A fresh charge of gas fills the combustion chamber as described before.

The cycle of operation then proceeds again as explained above. It will be understood that when the motor is running the induction takes place simultaneously with the compression of a previous charge (para. 5). Similarly, the compression of the crankcase charge (para. 3) takes place simultaneously with the explosion of a previous charge (para. 6).

#### *Glow Plugs and Their Construction.*

It is very important to fit the correct glow plug to a particular engine, and I shall have a few words to say on this point later. In the mean time let us see how this vital component is made up, for on its correct glowing powers the whole performance of the engine depends. A glow plug may glow either too fiercely or too weakly. In neither case will the engine function properly. It will be appreciated that the element and its length, in the form of reach into the cylinder where the element comes in contact with the burning gases, has an important bearing on the matter. It is also evident that engines with varying compression ratios, fuels and design factors must affect the glow plug's action. That is why I mention above that the correct glow plug should be fitted to suit the circumstances. Most readers will know from experience of either motor-cycles or cars that the correct spark ignition plug to suit a given set of engine and working circumstances is important, and that plug manufacturers issue charts in order to help the purchaser to make the right choice. The glow plug is even more touchy on this matter. An incorrect plug will often not carry on firing the engine after the battery leads have been detached, for it ceases to glow, and I know from experience that some plugs will produce much more power on certain engines than others. The Arden concern of America now sell plugs with detachable elements. One

runs hotter than the other. It is a matter of seconds to change over and see which element suits one's motor best.

The general make up of a glow plug will be seen in Fig. 7.

The glow plug is in effect a heater plug, generally similar in size and weight to a normal spark ignition plug. It is used to raise the temperature of the gases so that they ignite and operate the engine in a similar manner to spark plug motor, but without timed electrical spark ignition.

The electrical current (for starting only) at the element of a glow plug is a low voltage current and therefore does not give the modeller a shock should he unintentionally touch the plug or lead, as in the case of the spark plug's high tension current.

The glow plug has a coil of thin wire called an element, usually made of platinum or platinum iridium, in place of the usual electrodes of the spark plug. This thin element coil is heated by a battery for the start. After the start the battery is disconnected.

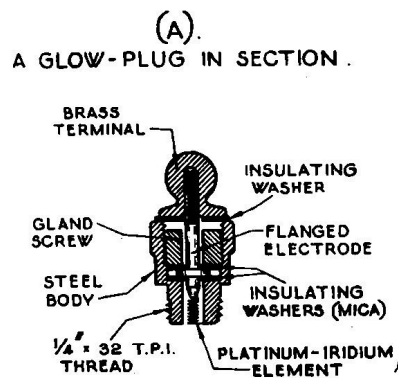

Fig. 7a—A glow plug in section.

(B).

ALTERNATIVE ELEMENTS.

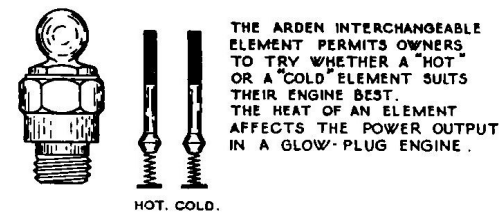

Fig. 7b—Alternative elements.

Too hot an element will reduce maximum speed of the motor by causing unduly early ignition, and too cold an element will not allow the motor to carry on firing after the starting battery has been taken away.

The super-speed boys in America found after much experiment that by moving the heating element up or down in the plug housing, the engine would gain or lose speed. This proved to them that the heating element position was a prime factor in obtaining the maximum horse-power from a given engine. It is not difficult to see that a hotter element ignites the charge better, and also earlier. It is in effect somewhat akin to advancing the ignition in a spark ignition petrol motor and like a spark-ignition engine, it is possible to over advance the spark and actually retard the all out revolutions of the engine.

There are three makers of plugs in Britain at the time of writing. Their products are each excellent, and if the modeller burns a plug out he should immediately suspect his methods rather than the plug. The correct method of operation is carefully given in this book, and if carried out plugs will seldom give trouble.

Bad usage can be briefly summed up—Incorrect starter battery voltage—Leaving the plug after the engine has started, with the battery in circuit—using a pair of pliers to unscrew the plug or screw it into the cylinder. The pliers often slip on to the small hexagon nut which retains the element, thus damaging it. A plug should always be screwed in or out of the cylinder by the means of a spanner. A box spanner is preferable.

The firms manufacturing plugs are firstly the well-known "full size" concern K.L.G. who were first in Britain to produce model glow plugs in quantity. Their plug is known as the "Mini-Glo"—the second is the British version of the "McCoy Hot Point" glow plug, which is well known in America. This plug can be obtained with a long reach and therefore often suits converted petrol engines. A short reach version is also sold. The other plugs mentioned have short reach at the time of writing. The McCoy plug concern also make an adaptor which can be screwed into a cylinder head having the larger plug orifice of  $\frac{3}{8}$  in. All plugs at present are  $\frac{1}{4}$  in. size. Many model petrol motors have the  $\frac{3}{8}$  in. hole. The third plug on the market is from the well-known model kit manufacturer of "Keil". The plug is known as the "Keil Kraft Gloplug".

*How Glowplug Ignition starts and works the Engine. The "Carburetter" and the Starter Battery.*

We have seen that the glow plug engine is essentially a normal petrol two-stroke motor but with a slightly raised compression ratio which burns a special fuel controlling speed of combustion. The fuel factors will be discussed shortly. The engine has no electrical gear to be carried by the model, but instead it has a heater plug which has an element that glows hot (*a*) by electrical energy from a starter battery which is subsequently disconnected, and (*b*) by the heat of compression and combustion.

Let us discuss the carburetter which provides the "explosive gas", and we can then follow through in detail the starting and operating of a glow plug engine. This will put the newcomer to the type into the picture as he will experience it. We can then discuss the fuel, mounting the engine, tanks, and so on.

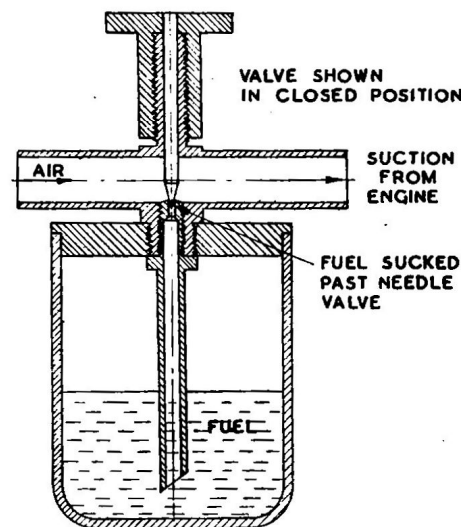

Fig. 8—The simple model type carburettor.

#### *The Carburetter.*

The carburetter can be seen in Fig. 8. On the average engine this is merely a mixing valve which allows the operator to vary the amount of fuel mixed with the air which is drawn into the engine by suction as already described. It is, however, important to grasp the fundamental but very simple action of a model "carburetter". A full-size carburetter is a complicated instrument of

compensating devices to deal with slow speed running, pulling, and running light, at low and high speed, and also speed all out running.

As our model engine runs flat out, or nearly so, a simple instrument in the form of an intake tube and a needle valve to control the fuel is sufficient, and what is more important it actually works better than a complicated instrument, as I know from considerable experience, having used model compensated carburettors with float and pressure feed on racing hydroplanes and aeroplanes. Except for very special purposes they are unnecessary complications. They were much used in the early days of model engines and are now almost entirely forsaken by the wise.

It is interesting, in passing, to see why the full-size instrument must be complicated. The requirements of a full-size instrument also show why the model instrument can be so simple, when it is remembered that only flat-out performance is required by the average model. The "Solex" people in their excellent little brochure dealing with carburettors tell us that these ingenious instruments, which most of us take for granted, must be designed with the following conflicting purposes in view. They liken the engine's "diet" to that of the human being, in that it must be balanced if a proper output of useful working energy is to be attained. In the case of the internal combustion engine, the diet is made up of the correct proportions of air to fuel.

- (1) Easy starting from cold or hot.
- (2) Idling or tick over.
- (3) Economy at normal speeds of traffic and touring.
- (4) Maximum power at high speeds.

The respective correct mixtures for the above requirements are :—

- for (1) 4 parts air to 1 part petrol (by weight).
- (2) 10 parts air to 1 part petrol.

- (3)  $15\frac{1}{2}$  to  $16\frac{1}{2}$  parts air to 1 petrol.
- (4) 12 parts air to 1 petrol, decreasing progressively as the speed rises.

Our model carburettors are content with No. 4 maximum power at high speeds. This perhaps answers some of the questions asked by modellers as to why the model instrument can be so simple when the full-size carburettor is so comparatively complicated.

Now look at Fig. 8 and it will be seen that the air is sucked down a tube, which must, of course, be of the correct diameter. The air rushes past a jet, and on the scent spray principle, draws the fuel up and mixes it with the air on its way to the engine crankcase. The amount of fuel allowed to pass is controlled by a needle valve which can be operated and set by the modeller. By turning the needle valve knob clockwise (right handed) he reduces the fuel that can be drawn up, for the tapered needle goes down into the jet orifice and so fills it to a greater degree, until finally when the needle is screwed right home, the jet is entirely closed. By unscrewing the needle valve, more fuel is allowed to mix with the air flow. Needles vary in the amount of taper given. But we may say that an average opening for a glow plug motor is one and a half turns, whereas the average for a petrol engine is one turn. Obviously, where a manufacturer fits a highly tapered needle, more turns will be required.

When starting a model engine the ratio of fuel to air requires to be increased temporarily (*vide* the "Solex" Requirement No. 1). This is done by simply placing the finger over the intake tube of the model carburettor, and turning the motor over one or more times, which sucks in neat fuel. When the finger is taken away the normal air supply enters the crankcase as the engine is turned over. The reader will remember that the resulting explosive mixture is then transferred to the cylinder head via the transfer port (See Fig. 9).



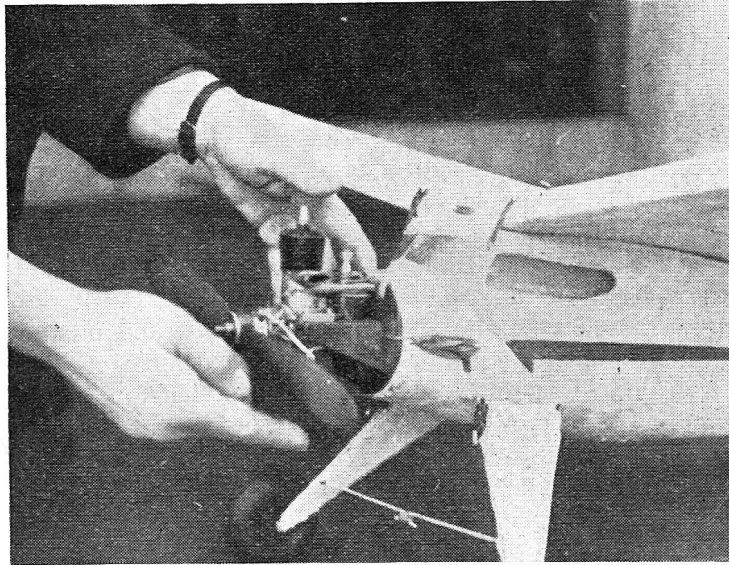

Fig. 9—To start the engine “choke” the carburettor with the finger over the intake and turn the engine over once or twice.

#### Tanks and Fuel Flow.

Fuel flow is much altered by tank location. This is dealt with in Fig. 10 which covers free flight or boat work other than round the pole hydroplane racing. This latter sport and control line flying introduce centrifugal force factors into the problem. Centrifugal force throws the fuel into the far side of the tank and naturally the pick up tube or line must be located at this side or the engine will be starved. Forward acceleration must also be considered or the fuel may pile up momentarily at the rear of a long tank, when the engine will be starved just at the moment when it requires a good flow of fuel, if the pick-up tube is situated at the front end or middle of the tank. The best position is therefore at the rear and far side of a tank, which the modeller may build himself from sheet metal. This form

of fuel supply is adequately dealt with in Chapter IV, diagram Fig. 27.

Incidentally the tank for a glow plug motor should be of metal because the fuel generally used dissolves the plastic or celluloid materials normally used by petrol engine manufacturers.

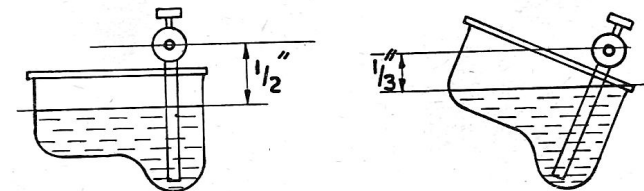
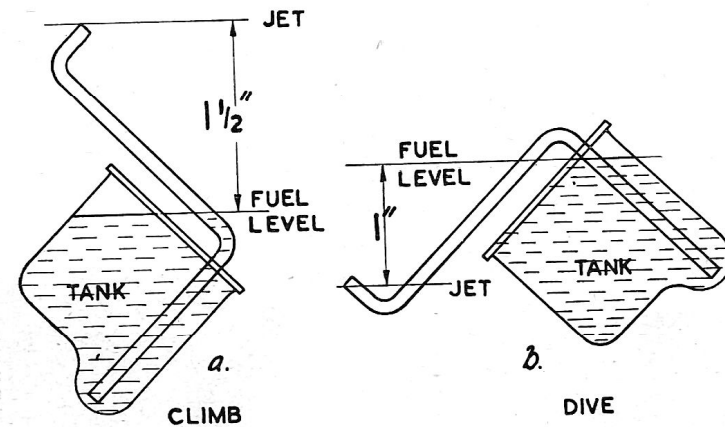

#### NOTE VERY SMALL VARIATION IN LEVEL OF FUEL

Fig. 10—The correct and incorrect way of fitting suction fuel feed on aeroplanes and boats. Control line requires further precautions. (Chapter IV, Fig. 27). The wrong method is, of course, above, correct below.

*The Starter Battery.*

Having grasped the working of the carburetter and how the gas is produced, we can turn to the engine and start it up, being careful to use the correct starter battery and the right voltage.

The glow plug is heated by a battery *which must not be of a greater voltage than 2*. Any increase in voltage will burn out the plug. The battery for British plugs is best in the form of a two-volt radio accumulator. Certain American plugs will not stand more than  $1\frac{1}{2}$  volts, in which case either a heavy duty bell battery must be used or an accumulator with a resistance in one lead.

The glow plug takes a very heavy drain from the battery, therefore dry batteries are often exhausted in one afternoon's starting. They are expensive items and it is

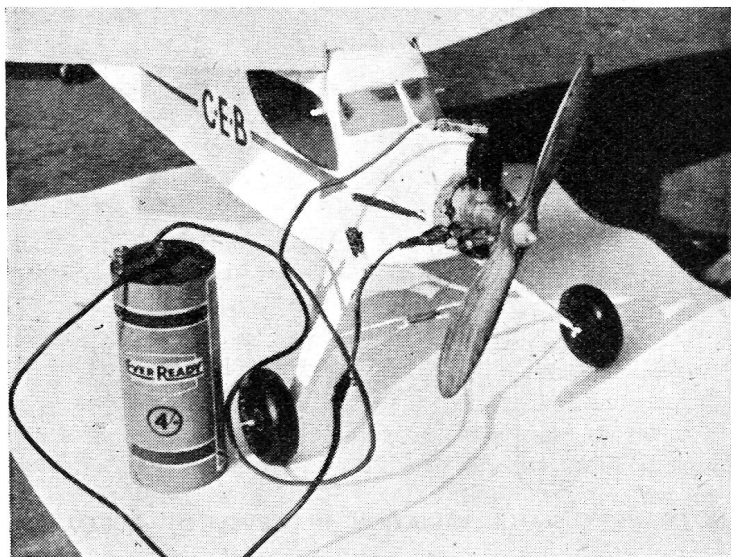

Fig. 11—Starting the American baby Arden with a  $1\frac{1}{2}$  volt dry cell. Immediately the engine starts the battery must be disconnected.



Fig. 12—The author's Meteorite model fitted with a British glow plug that can safely take a 2-volt accumulator for starting.

far more satisfactory to buy a two-volt "wireless" accumulator from the local radio shop. This should preferably be at least 45 amps. Smaller accumulators require too frequent charging. A good accumulator as described can then be recharged or freshened up periodically, either by a home trickle charger from the lamp circuit, or by taking to the radio dealer. I cannot too strongly advise modellers to use an accumulator rather than a battery. It is far cheaper on the pocket and far more reliable and generally satisfactory. A good 2-volt accumulator will last for years if periodically given a charge, and distilled water added as necessary.

When it is realised that the average glow plug has a consumption as high as 8 watts—4 amps. at 2 volts, it will be realised a dry battery is not satisfactory. The owner

will so often damn the engine for not starting when, in fact, it is the failure of starting current that is to blame. In order that the reader shall grasp the problem clearly, I am including three photographs of starting engines showing various forms of starting electrical source. The first shows an engine being started by a bell battery of  $1\frac{1}{2}$  volts as used for certain American plugs. The same engine could be served by the second method if a resistance of  $1/8$  ohm at 4 amps. is placed in circuit, thus ensuring a reasonable life for the plug. The second photograph shows a model of mine being started up by 2 volts from a 6-volt accumulator. Modellers often have a 6-volt motor-cycle accumulator for petrol engine work. In this case the leads can be attached to the positive terminal and the adjacent negative terminal which will give only 2 volts. The third photograph shows the method which is best for the average new modeller. In this case a 2 volt radio accumulator is used with two stout heavy-duty leads which pass the current easily, attached to the engine by crocodile clips. These clips are easily attached and quickly detached. The positive clip can be attached to the glow plug and the negative clip can be attached to any clean part of the engine's metal body. This makes the necessary circuit to cause the plug's element to glow. The crocodile clips on plug and engine can be taken off as soon as the engine starts, one being snapped on to the other's lead so that they cannot short by touching each other on the ground.

#### *Starting Procedure.*

(1) Most engines run anti-clockwise, so swing propeller or flywheel from right to left.

(2) Open throttle needle valve several turns, place finger over the air intake to choke, as glow plug fuel is sticky stuff. Turn engine over once or twice and see if fuel shows on finger. This proves that fuel is flowing. If no signs, blow through fuel line after detaching. Also blow through needle valve to clear gummy oil. I use a

piece of bicycle valve tubing which I keep with my starting accumulator for this purpose.

(3) Close fuel needle valve to the "best run position", which is usually stated when buying a new engine. If a converted petrol motor is being started for the first time, remember that the running opening of the needle valve will be greater than when the engine is used with "petroil" mixture. Glow plug fuel (see Chapter on fuels later) generally burns at a greater consumption and has a thick castor lubricant to pass through the needle valve orifice.

Glow plug motors therefore usually require a greater opening of the needle valve and a good choke on starting. The castor oil lubricant is inclined to make the engine "sticky" to swing when cold, so it may be necessary to suck in several times to free it. This will have the effect of flooding the engine. The plug may then be heard sizzling, and vapour will be seen at the exhaust ports. Any attempt to start may cause the engine to oscillate its propeller rapidly back and forth. In this case close the needle valve and allow the excess fuel to burn away, then repeat the starting procedure.

(4) Having sucked in, connect one lead to the glow plug and the other to the frame (earth) of the engine. This is done by crocodile clips as previously mentioned.

(5) Swing the engine *smartly* to start.

(6) As soon as the engine fires reasonably well *disconnect the battery leads*. This is vital to prevent burning out the plug which will not stand the combined heat of electrical energy and combustion of the engine. It will be noted that a properly suited plug to engine will cause the engine to rise in r.p.m. as soon as the battery is disconnected. Ignition is too soon when battery and combustion heat are combining together to create too fierce a glow. If, on the other hand, the plug is too "cool" for the engine, there will be no improvement in running, in fact the engine may not carry on firing.

If the engine hesitates but runs, it is permissible to touch the plug a few times to pick up the adjustment, as long as the battery is not kept in circuit for any appreciable length of time.

The glow plug engine is more critical than the petrol motor to correct mixture strength. This is because a rich mixture cools off the plug and douses the glow. It is absolutely vital that the correct mixture strength shall keep the heat of combustion high and constant so that the plug will carry on glowing properly by itself and without electrical aid, when the starter accumulator is disconnected. Control line models and circular course hydroplanes often bring a glow plug engine to a standstill through alteration of the mixture strength as the speed rises and more fuel is flung by centrifugal force into the intake fuel pipe. It is therefore most important on these models to fit a suitable tank as described in Chap. IV which ensures a constant

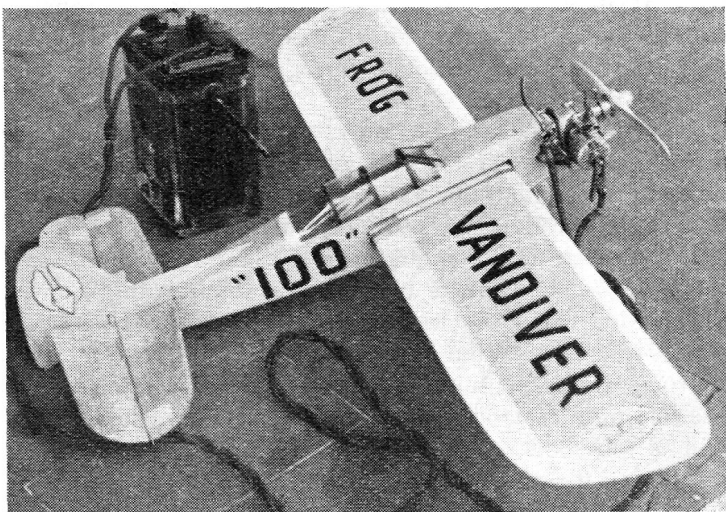

Fig. 13—The best battery for starting. A 2-volt radio accumulator of large capacity. The model is a Frog "Vandiver" powered by a "Frog 160" glow plug engine.

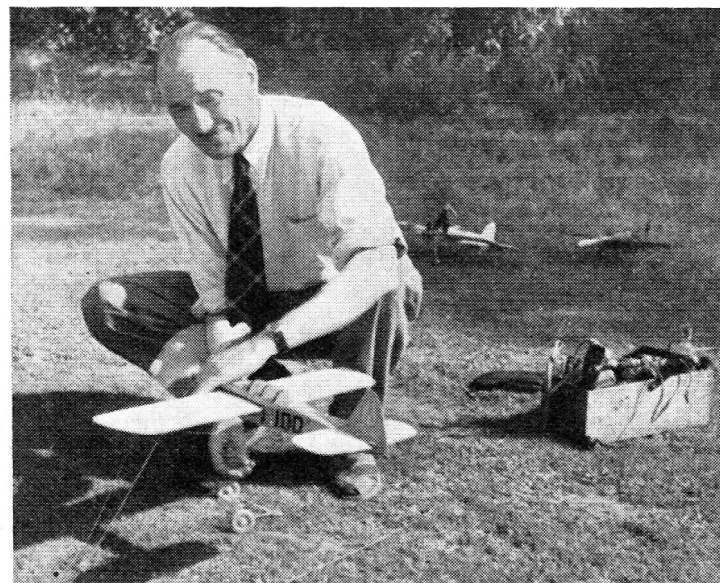

Fig. 14—Mr. Cathcart getting his mixture right with rapid and practiced hands prior to a control line flight with a "Frog 160" glow plug engine.

mixture strength irrespective of speed in alteration.

Readers who are used to the diesel's easy going nature regarding mixture strength adjustments of the needle valve, will at first find the glow plug motor rather disconcerting if they have not been forewarned. Once the engine has started it is therefore advisable to tune the needle valve to get the best mixture. *This does not mean fiddling with the mixture until the engine has emptied its tank as some people do. It means quickly and with practised fingers making a sound adjustment and leaving it.* Those who fiddle with adjustments on model motors never have success, whilst the spectators get utterly bored watching their tiresome efforts.

Fig. 14 will remind the reader to run up his motor before release.

(7) If the engine will not start, check up that the plug is glowing properly. This may be done by taking out the plug, *using a spanner and not a pair of pliers*. When the plug is connected to battery and touching the motor frame, with the other lead clipped to "earth," the plug should glow brightly and red. It is however seldom necessary to take out the plug, as it can be seen to glow red in the cylinder if the piston is turned back so that it uncovers the exhaust port. **NEVER USE MORE THAN TWO VOLTS.**

(8) If the mixture is too weak the engine will misfire and slow down. If the mixture is too rich the engine will "Four-stroke," or cut out completely as though the ignition had been switched off in a spark ignition motor.

(9) When you have finished running for the day, remove fuel line and drain tank, or otherwise empty tank, as sticky oil will clog up the fuel lines if the fuel is left. Castor oil lubricant tends to separate from the fuel. *Therefore the fuel should always be shaken up before use.*

(10) It is a good practice to squirt a few drops of castor oil into the cylinder after use. The motor should then be turned over.

(11) Remember that a special fuel as described in the chapter on fuels must be used.

*Essentials of Hot Point Ignition.*

- (1) A special fuel.
- (2) A suitable compression ratio.
- (3) A plug to suit the compression ratio.
- (4) Cylinder head design which prevents "shrouding" of the heater plug.

The American firm of Ohlsson and Rice, who make the famous Ohlsson range of engines, make the following sage remark. "For successful glow plug operation it is necessary to accomplish a very definite and careful balance between the heat of the plug, the fuel used, and the compression ratio". This precisely sums up why certain combinations of plug and engine do not function satisfactorily. When a modeller

puts "any plug" into his ancient petrol motor, although he may use one of the recognised special fuels, it is quite possible that the engine will run badly or even stop altogether.

I have found that many of my old petrol engines will run quite well if I fit them with a make of plug that suits them, but there are no results with another make of plug. Plugs are made to suit different heats of compression.

When the starter battery is switched off, a glow plug ignition engine is in effect running in a similar manner to a diesel, except that the fuel is ignited by the "hot-coil" plug instead of by compression only. Because of the necessity of keeping the plug glowing, the speed range is limited. It is not normally advisable to run such an engine at speeds less than 6,000 r.p.m.

High compression and a glowing plug fire the charge early, therefore a fuel that will prevent too early burning and detonation is necessary, or the piston will be driven back in the wrong direction or pull up the motor's speed by offering great resistance before the top of the stroke is reached, in similar manner to the diesel when it is run at too great a compression adjustment. In other words the fuel must burn with a slight time lag and have anti-knock features. Alcohol is generally used for the above purposes. Fuel is therefore given a chapter of its own, because a glow plug engine will not run properly on any but a special fuel.

Almost all engines will run on glow plug ignition if the compression ratio is sufficiently high, and the plug is not overcooled by shrouding. A compression ratio of approximately 8 to 1 is very suitable. Shrouding of the plug's element keeps the flame of combustion from heating the plug. If the plug gets cool, it does not then fire the next charge.

The American speed fiends even go as far as "winkling" out the plug element with a pin so that it stands out proud. They try different lengths until the highest r.p.m.

are obtained. What a lot of plugs must be damaged!

In the petrol engine the designer times his spark to ignite the gases so that a late push is given to the piston at starting and slow running, and an earlier explosion or push as the engine speeds up. The glow plug engine cannot do this. The only control is by burning a slower burning fuel. The engine must run flat out once it is started except for a very small variation due to a richer mixture that does not actually cool off the element sufficiently to stop the engine running. How compression ratio affects fuel is discussed in the next Chapter II.

*Advantages of Glow Plug Engines.*

This book gives the advantages of using the glow plug engine, such as weight reduction, etc., but there are, of course, the very real advantage of simplification in building the model for the engine. Just think of all the scheming and the actual labour that spark plug ignition creates. All the wiring of booster battery, the battery box, and time switch and so on, which takes so much time to do, not to mention the gear that has to be carried to the flying field. All this is done away with. Models can be made far more quickly and with less expense, and carried to the field of operation with far greater ease. In fact, it is very much the same story as the diesel which brought in so many people to power flying who had been wavering on the brink. The glow plug engine seems to be a bit more exciting than the average diesel. I think this is really more due to noise than anything else? The large capacity diesel in the 10 c.c. class scarcely exists, and here is where the glow plug engine comes to the fore, although I for one can not resist the snappy performance of the little glow plug motor either. The fact is, *all* model internal combustion engines including the jet motor have a vast interest, and one leads to the other. They all have their uses, and I have no doubt that many of my readers will keep the lot in their hangar to suit varying moods and models.

CHAPTER TWO

*The Fuel for Glow Plug Ignition.*

*The Requirements.*

EARLY experiments with fuel in America led to the "ignitionless" operation of normal spark ignition petrol engines. Spark ignition was used to start up. It was then removed after about one minute's running to thoroughly warm up. A fuel having certain chemicals added to lower the flash point and add to ignitability were used. It was found that the normal spark plug's electrode, when thinned down, remained sufficiently hot to cause self ignition. The model was then launched without ignition gear and flight battery. The fuel contained 35% petrol, 20% nitromethane, 10% ether, 10% spirits of turpentine, 25% castor oil.

From these experiments Mr. Arden developed his "Glo-plug", which eliminated the high tension spark equipment altogether.

High compression and a glowing plug fire the charge early as the piston rises on its compression stroke. Therefore a fuel that will prevent too rapid burning and detonation is necessary. Even then high revolutions will be the order of the day, and a fuel that will fit in with this characteristic of the glow plug engine is required.

If an incorrect fuel is provided, the rising piston will be driven backwards, or will be pulled up, and the speed of the engine retarded, causing excessive strain and stress on the engine. Also undue wear is imposed upon bearings. In other words, the fuel must burn with a slight time lag and have anti-knock features.

Alcohol is generally used for the above requirements, therefore we will discuss its properties. A high compression

ratio is required to cause heat when the gases are compressed at the top of the stroke.

*Alcohol.*

Alcohol is less subject to knocking because of its higher resistance to preignition than possessed by petroleum in a spark or glow plug engine. It is a suitable fuel for compression ratios between about 7 to 18 to 1. Alcohol fuels are known as cool fuels, and cooling fins can be less when it is used. The reader may have noticed how small the cooling fins are on the popular dirt track racing J.A.P. motorcycle single cylinder engines using alcohol racing fuel.

Methanol fuels contain a major percentage of this light, volatile, inflammable fuel. Methanol is derived from a distillation of wood. It is suitable for engines having a compression ratio ranging from 7 to 14 to 1 (dirt track motorcycles engines have a compression ratio of about 14 to 1). The average glow plug model engine has a compression ratio of approximately 8 to 1, rising to 10 to 1 or even 12 to 1 in special cases.

A methanol base fuel is used for most glow plug engines.

Methanol keeps engine temperature moderate. Whereas it takes about  $15\frac{1}{2}$  parts of air by volume to burn one part petrol efficiently, it requires  $8\frac{1}{2}$  parts by volume of air to burn one part of alcohol. *Alcohol fuels therefore have a higher consumption figure than petrol.* A model enthusiast brought his new glow plug engine to me convinced it was faulty because it had to have the needle valve open much further than his diesel by the same maker. He was also sure that the engine was not up to standard because it "used so much more fuel."

My answer was of course contained in the above facts regarding air fuel ratio. We may therefore say that alcohol fuels have a higher consumption than petrol, and that is why the model man who requires a long engine

run must make a larger tank than he has been used to when running on a "petroil" mixture with his spark ignition engine.

Some readers may perhaps have run a motor cycle or a car on alcohol racing fuel for a while during the petrol shortage. They will have been worried by not only the heavy price per gallon, but also by having obtained only approximately half the mileage per gallon they were accustomed to. This extra fuel consumption is of no great moment to the model man for his fuel bill is so small!

The Americans use nitro-methane extensively, added to the methanol basis of their glow plug fuel. This additive definitely gives what they term a "souped up performance". For instance, I and other people in this country, who have used nitro-methane added to our fuel, have all agreed that it provides between 500 to 1,000 extra revolutions per minute on most engines of a reasonably high compression ratio and having the porting to permit high revolutions.

Nitro-methane is almost unobtainable in Britain today, and when it can be got it is fantastically expensive. This makes it out of the reach of normal commercial fuel blends for glow plug engines. Perhaps in the future the situation may alter in this respect.

The loss of nitro-methane need not cause us undue alarm however, for even straight methanol with glow plug ignition will usually give a better performance than the average spark ignition engine, especially taking into account the fact that the weight of ignition gear has not to be carried by the model.

Furthermore, there are substitutes such as cellulose solvents in Britain which give a very similar effect, although perhaps not quite so outstanding. British commercial glow plug fuels are now ready blended with that "little something" which helps a slight extra urge and keeps down any tendency to detonate, nitro-benzene being one of them and acetone another.

Other chemical additives which we can obtain are Amyl-nitrate, Amyl-acetate, Ethyl-nitrate. The latter is nearly as effective as the American nitro-methane when added at 5 to 10%. Amyl-acetate is the least effective, but a slight improvement on straight methanol is found if added at 2%.

Our fuels give all the speed and power that we can reasonably wish for, and they are "safe", which nitro-methane may prove not to be when mixed with certain ingredients. We are all in the same boat over here even for our speed machines, so why unduly worry! Anyway, there is so little in it, and we can get all the practical fun we want with our special fuels.

Nitro-methane is extremely hazardous from the fire standpoint, the flash point being 112 degrees F. If used as a fuel additive there is a definite risk, and under no circumstances should the modeller add anything but castor oil and alcohol to nitro-methane. Some chemicals when added to nitro-methane make it *sensitive to detonation from shock*.

If the modeller wishes, he can mix his own fuels as laid down below, and these will give him more power than he is used to with his "petrol" fed petrol engine.

#### *Commercial Fuel Blends.*

There are two concerns already blending glow plug fuels in a large way. International Model Aircraft provide a ready mixed fuel, blended by Shell, B.P. This fuel has the correct amount of castor oil for lubricant added to the fuel. It also has a 2% anti-knock component. The fuel is called FROG "Red Glow".

Henry J. Nichols has two fuels for glow plug engines. These are blended "with the co-operation of the research staff of the Anglo-American Oil Coy", by the High Flash Petroleum Oil Co. Ltd. Each fuel contains what is advertised as an "Ignition Fraction". The first fuel is called

"Mercury Competition Glow Plug Blue Label", for engines with a compression ratio up to 8 to 1. This has a *gasoline* base with Essolube Racer lubricating oil. The second has the normal methanol base and castor oil lubricant, and is known as "Mercury Racing Glow Plug Magenta Label". It is for compression ratios over 6-5 to 1.

#### *Home Mixtures.*

Most engines will run well on the very simple mixture of one part "Castrol R" (Wakefield's) to three parts Methanol. The methanol can be bought from a chemist. It should be to B.S.S. Specification No. 506/1933.

Castor Oil can be either Wakefield's "Castrol R" or Shell super heavy (castor). Either can be bought from a garage.

If either castor oil or methanol contain impurities, they will not mix together properly, but will turn milky.

Another mixture is: Methanol 80%, Benzol 10%, Aviation Petrol 10%. Add "Castrol R", 25% by volume.  
*An American Mixture.*

Castor Oil, 2 parts. Methanol, 3 parts. Nitro-methane, 3 parts.

#### *Lubrication.*

Two very different types of lubricant are in existence. Castor oil is vegetable. Other oils for cars and motor-cycles are mineral. Mineral oils will not mix with alcohol fuels such as methanol. In this case castor oil must be used.

It will be noted that where methanol is shown in mixtures given above then a castor oil is used as a lubricant so that it will mix properly. Even good castor oil has a tendency to separate from the fuel if left standing for any length of time. *Therefore the fuel bottle should always be shaken before use, and the tank drained after use.*

Castor oil can be recognised by its neutral clear appearance, and also that wonderful smell when it is burning, which stirs the enthusiastic race fans or the early aeroplane



pilots. The old rotary aero engines used it, and incidentally flung most of it out upon the person of the pilot. I can never sniff burning castor oil from an exhaust without getting a nostalgic kick from my early flying life. It is very sticky stuff, and becomes more so when subjected to great heat. It therefore tends to gum up fuel and oil lines which require care in respect of cleaning.

Mineral oil is usually a greenish colour, and is used in most standard road machines whether they be cars, motorcycles, or lorries. It is therefore familiar to many people. It mixes well with petrol, and will remain mixed once well shaken up. There is an authentic case of a two-stroke motor cycle being laid up for the war with some mixed "Petrol" in its tank. At the end of hostilities the machine was started up and run till the tank was emptied, thus proving how well mineral oil can be mixed and remain mixed with petrol. I often leave my model petrol engines' "petrol" mixture for months at a time in the fuel bottle, whereas I always find a castor oil methanol mixture requires a good shake before use even if it has been used only the previous day.

*Methanol Damages Tanks Made of Celluloid, Also Dope or Paint Finishes.*

That lovely finish you have taken so much trouble to obtain will be ruined in one day's flying or use when a methanol fuel is used, unless a special protective finish is doped over the normal finish. There are several protective finishes on the market specially produced for the model glow plug engine fan. These can be bought from good model shops. Some are coloured as well as clear, such as "Uncle Oswald's Marjonos".

Celluloid tanks dissolve under the influence of methanol, therefore metal tanks are used, made from thin sheet brass or tinfoil, and soldered. Some people maintain that brass corrodes. I have not found trouble in this respect.

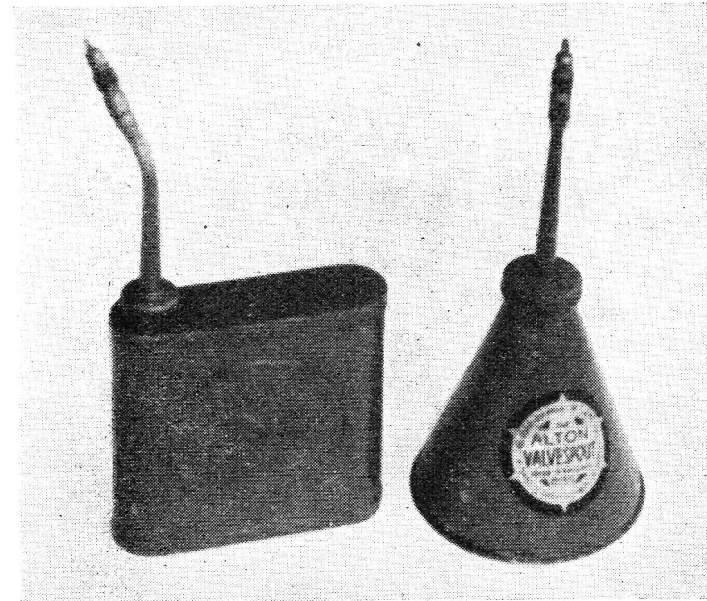

Fig. 15—A very useful can with screw top obtainable at any model shop or ironmonger. The round base is the more stable

#### *A Simple Way to Carry the Glow Plug Fuel.*

Obviously a metal or glass fuel bottle for the field is required, for celluloid containers will not do. I have found nothing better to date than the ALTON "Valvepout" oil can. These can be bought from model shops or ironmongers, and are painted red. The type which has a round and wide base seems preferable to the narrow rectangular can, for the wide circular based can is easily put down after filling the model or "doping" it, and the base keeps the can upright without toppling over. The secret of these cans is in the spout top, which is sufficiently small to pour fuel into the average model fuel tank orifice. The top also has a quick screw thread which permits the can to be opened for pouring or closed after use when it

becomes leak proof. The screw top is integral with the filler tube. There is therefore no top to be lost in the flying field grass.

*Castor Oil Lubricant Keeps Rubber Bands in Good Order.*

Those sensible aeromodellers who attach their engine mounts and aeroplane noses, wings and so on, by the means of rubber bands, will be delighted to find that the rubber bands have a long and useful life when they use a glow plug engine and a castor based lubricant. The castor oil keeps rubber supple.

Methanol attracts water and therefore an engine which is being left unused for a long period should be well oiled or certain parts may rust.

CHAPTER THREE

*Glow Plug Engines.*

ALMOST every American engine manufacturer has turned his attention to at least one special glow plug engine in his range.

In Britain various firms are getting down to the problem with vigour at the time of writing this book. It must, however, be remembered that the glow plug engine is well established in America, and is only now getting under way here. Readers are reminded that they can make a start if desired by first converting one of their more modern petrol engines, or they can start off with one of the already successful British glow plug motors.

In the next chapter I describe how to convert an existing petrol motor, and also how to weigh the chances of success. Not every petrol engine is worth converting, as some of the older ones run roughly and have no increase in performance.

The engines that have already been specially produced by manufacturers for glow plug ignition are already highly satisfactory in most cases, and I feel convinced that more and more manufacturers will take to glow plug ignition in Britain, just as the American market has developed in this direction, as soon as we over here have had time to assimilate the very real advantages of the system and its few shortcomings. We always take our time to develop something that another country has started, but once we get going things usually move rapidly.

This book has to be limited in length, and therefore I have selected a few examples of existing glow plug engines from America and in Britain, which will serve to show the general trend of design to those interested in the type.

Fig. 16 shows the well known OHLSSON 23 glow plug engine from America. This firm has been making petrol engines for many years, and has set the pace with regard to price reduction in that country, allied to progressive design and high efficiency. I have had many OHLSSON engines over the years and found their standard very high, with exceptionally easy starting.

The engine shown in Fig. 16 has been seen in section in the previous chapter. (Refer back to Figs. 2 and 3.)

Readers will note the vast induction intake located in front of the engine. This is a good point in glow plug engine design, because the type, as already remarked, must be able to turn at high revolutions. Good "breathing" and an easy transfer of the charge, followed by quick and free exhaust of the burnt gases, are largely the secrets of a first class glow plug engine. This has to be backed up by a very free turning engine. Most of the American engines, including the OHLSSON, have ball races to help this last feature. It will be observed that the exhaust port on the OHLSSON is almost large enough to crawl into!

It will doubtless interest readers to note the above points in the other engines illustrated. Naturally, some are better provided with good features than others. That is the way with all design, but it will be observed that all engines shown conform in general to these features so necessary to satisfactory glow plug operation. When choosing a glow plug motor, look for large ports and a free turning engine, but one with reasonably good compression.

Perhaps the first glow plug engine to be produced in quantity in Britain was the FROG 160 RED GLOW engine. It is a very powerful motor for its small size of only 1.6 c.c.

Besides making an excellent high performance free flight power unit or a small speed boat engine, it has such a fierce performance when well run in that it provides a new type of easy stunt control line flying. Not long ago,

it was necessary to fit a large petrol engine into a large model to stunt really well. This was due to the necessity of keeping the lines really taut throughout a stunt movement, thus keeping proper control. The little diesel would not do this without a certain amount of stepping

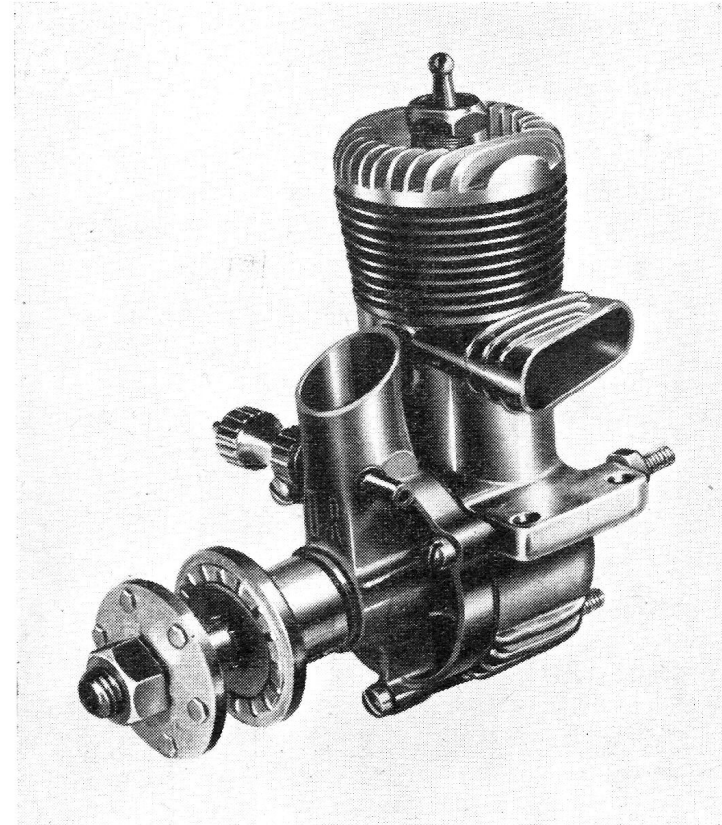

Fig. 16—The famous "Ohlsson 23" glow plug engine from America. Note very large ports which assist high revolutions so necessary in good glow plug operation.

back, etc., and the model had to usually be one of the very unrealistic type having only two main longerons for lightness. The FROG has made it possible, with its fierce power output, to make little models having a balsa sheet rectangular fuselage looking something like the real thing, and yet having the virtue of really easy stunting. The FROG VANDIVER model aeroplane can do any "stunt in the book". With the engine properly tuned for mixture strength, the lines are like "rods", and stunting becomes absurdly easy. The undercarriage is dropped after taking off. The price of the engine and the aeroplane kit are very low and will encourage many a boy to enter into control line flying with a zip.

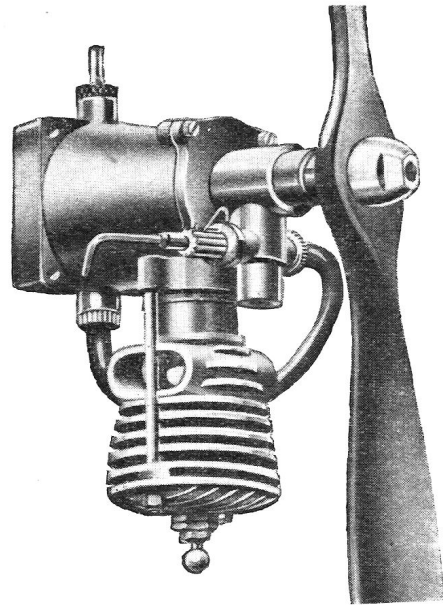

Fig. 17—The "Frog Red Glow 160" engine was one of the first glow plug engines of small capacity to go into production in Britain.

Lines of approximately 45 to 50 feet are suitable for these little models. Two suitable models are shown in the last chapter.

The FROG RED GLOW engine has a static thrust of 20 to 22 oz. at 9,000 r.p.m., under load of the FROG plastic propeller. Readers will probably realise that static thrust can be misleading as to what an engine can put out when it is flying at speed, and when the propeller blades are really gripping the air and not slipping. Nevertheless, static thrust figures are a useful indication, in spite of what some people may say on the matter. Naturally, a brake horse power test is the best, but this is by no means always possible to obtain accurately in the model world.

The weight of this engine is 3.25 oz. There are two propellers available made from plastic, which have the great merit of being constant in performance, as they are not subject to the variations of hand carved propellers. They are also cheap to replace and they have a sufficient weight which makes for easy starting and smooth running. The blade section may suffer somewhat from the ideal, but from much personal experience I have found that the plastic propeller suits a FROG engine far better than many much talked about carved propellers. It is performance in the air that matters, and FROG engines excel in this.

One propeller has a diameter of 8 in. and pitch 5 in. for free flight, and the other has a diameter of 8 in. and 6 in. pitch for control line work. The FROG uses a K.L.G. MINI-GLOW plug, and likes the FROG "RED GLOW" fuel. The engine has a cone tank-cum-engine-mount, which is easy to bolt up to a forward bulkhead of an aeroplane or a cross bulkhead in a boat.

Like all glow plug engines, the FROG performs best when fully run in.

The Americans have developed the large 10 c.c. motor to a very high degree. Britain has lagged behind in this respect until recently. The 10 c.c. engine gives great

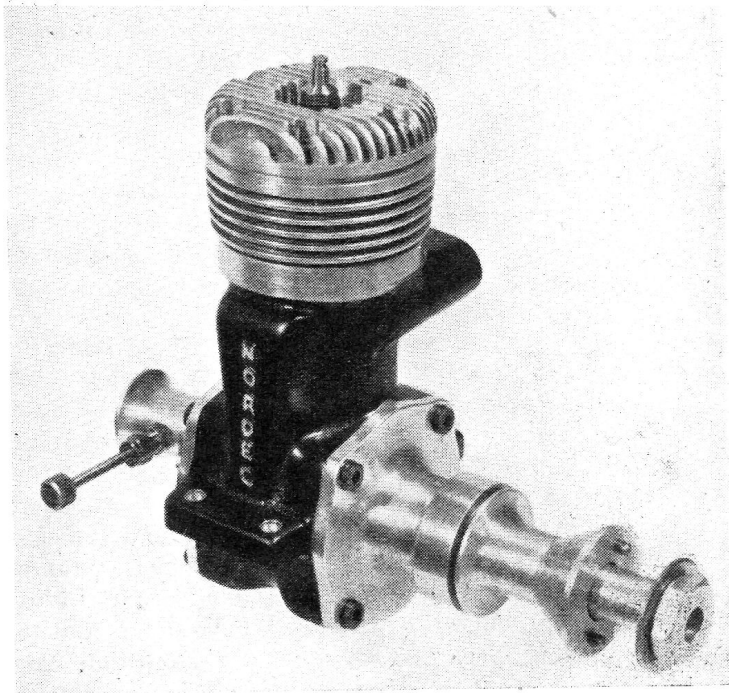
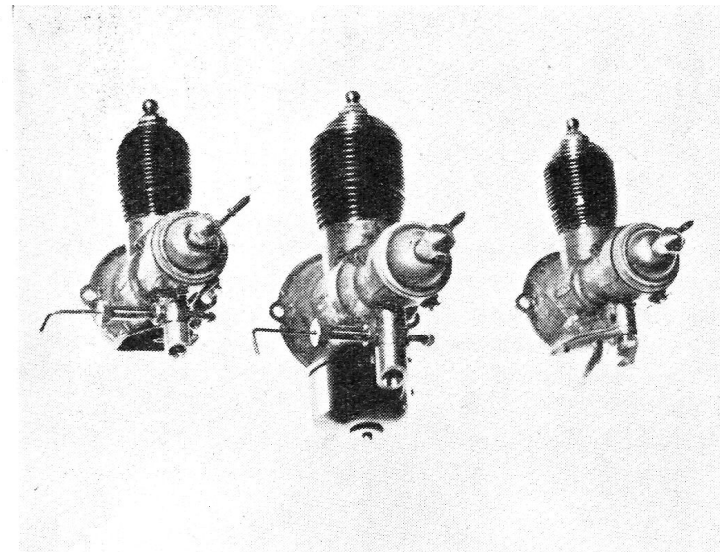

*Fig. 18—The British "Nordec" 10 c.c. is a much needed really "hot", large capacity motor on well proved American lines. The engine has piston rings, disc rotary inlet valve and two ball races.*

power and is suitable for racing model cars, hydroplanes, speed boats of the vee bottom planing type, and, of course, the really hot speed control line model aircraft. It also makes an excellent capacity for large radio control models, but many will consider that spark ignition is better for variable speed control in this latter case.

A British firm has produced a really powerful racing glow plug engine of 10 c.c. on American lines. This engine is called the NORDEC, and has already put up a British

control line record in its class, the speed being 95.3 m.p.h. A glance at the photograph in Fig. 18 will give a clue to the secret of this engine's success. Note the large ports, the rotary disc inlet valve, the robust construction that ensures a "stiff" engine in the sense that high power will not distort the structure and so cause friction. Ball races are also used, and piston rings are provided, as they should be on all engines of this capacity given to high revolutions. It will be noticed that the intake is situated at the rear, and gives an easy path for the incoming gases through the disc inlet valve. The NORDEC is produced as a glow plug engine without contact breaker gear, or as a petrol timed spark ignition engine when a sensible car type contact breaker is fitted. The engine I use is well finished



*Fig. 19—Very outstanding glow plug engines are made by Arden, who was a pioneer of this type. The engine in the centre is the larger 1.99, those on the outside are 0.99 cu. in.*

as in the case of American engines, and American engines have a deservedly good reputation for finish. The engine has a very hot performance, too. The makers claim it turns round at 12,000 r.p.m. when fitted with a 9 in. diameter 10 in. pitch propeller, or at 22,000 r.p.m. when running light with a flywheel. Personally, I am more impressed by actual performance than in makers' claims of revolutions, etc. But certainly the NORDEC comes up to expectations as regards performance when fitted to models. The engine should have a big future in front of it in Britain. Although not cheap, for there is obviously a great deal of careful fitting in such an engine with piston rings, etc., it fills a long felt want in this country.

ARDEN American engines have a great reputation all over the world for small capacity, light weight, fine finish and integral design, also a terrific performance for size. Their exhaust note alone is most inspiring! This is doubtless due in part to the unusual feature introduced by Mr. Arden of a ring of ports completely encircling the cylinder. These engines are well worth studying by all enthusiasts interested in high efficiency glow plug engine design. They are really very wonderful engines. I am fortunate in possessing two of the baby .099 cu. in. engines and the larger .199 cu. in. motor. It will be noticed that the engine is formed in one casting with its mount so that it is very easy to bolt up to a nose bulkhead, and it looks extremely neat and workmanlike. The Arden is perhaps the most obliging glow plug motor that I know. It runs on almost any fuel and any plug. This is perhaps not surprising, as Mr. Arden was a glow plug pioneer, a fact that I mentioned in Chapter I. Starting is the easiest I have experienced, requiring one squirt of fuel into the exhaust ports and off she goes with that ear splitting but exciting exhaust note. These engines are, of course, fitted with ball races. The baby does a good 10,000 r.p.m. with propeller. In fact it produces its best power at this

speed. A maintained 20,000 r.p.m. is claimed when running light with flywheel. An official American flight of 76 m.p.h., and unofficial flights of over 90 m.p.h. have been made with the baby ARDEN of .099 c.c. The 199 c.c. engine has officially done 109 m.p.h. in 1948.

The .099 engine uses an 8 in. by 4 in. propeller, and a 10 in. by 5 in. is used by the larger .199 engine. These propeller sizes permit the necessary revolutions to be developed. A slightly higher pitch may be used for fast control line models.

Mr. Arden has the interesting conviction that a diesel engine to be dependable should have a greater stroke-to-bore ratio, but this however does not hold true with spark ignition or glow plug ignition. As he has designed and produced so many winning baby engines right back from the early days of the model internal combustion engine, his remarks on the subject will command respect.

ARDEN engines have the piston joined with the connecting rod by means of a ball and socket bearing which permits the piston to rotate as it reciprocates. It is claimed that this feature assures the maintenance of perfect cylindrical surfaces on both piston and cylinder with even distribution of wear. The 360 degree exhaust and intake porting construction is an innovation in model two stroke design. As a result, the exhaust gases are expelled radially from the cylinder at the bottom of the piston's stroke, and are replaced by incoming fresh fuel, in the form of a jet spray, through spaces between the piston and cylinder wall, resulting in high efficiency operation and exceptional starting.

E.D. are well known for their excellent diesels made in Britain. This firm has produced a combined diesel-cum-glow-plug engine. It is known as the MARK III, having a capacity of 2-4 c.c. I use one of these engines in a flying boat. For its light weight this small engine is very powerful as a diesel, and has the capacity for high revolutions.

Apart from forming an excellent power unit for small to medium size models, the engine has the interesting feature of being sold with two detachable cylinder heads. One of these allows it to be run as a diesel. The other can be quickly changed over and the engine becomes a glow plug motor. Fig. 20 shows the engine fitted up as a diesel, with the alternative glow plug head lying on the ground beside it. I have found this engine is best as a glow plug engine when it is very well run in and quite free. It will be no surprise to readers of this book, for I have gone to some pains to emphasise that a glow plug motor must be really free and capable of high r.p.m. It will be noted that the exhaust porting is large. The high revolutions are assisted in the engine by what the makers term "induction boost".

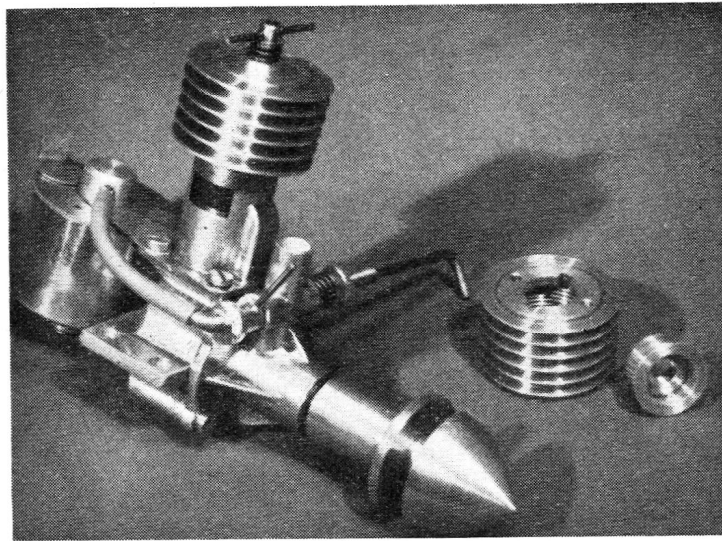

Fig. 20—The "E.D. Mark III" engine can be run as a diesel or a glow plug motor. Changeable cylinder heads are provided. Note the exceptionally long crankshaft.

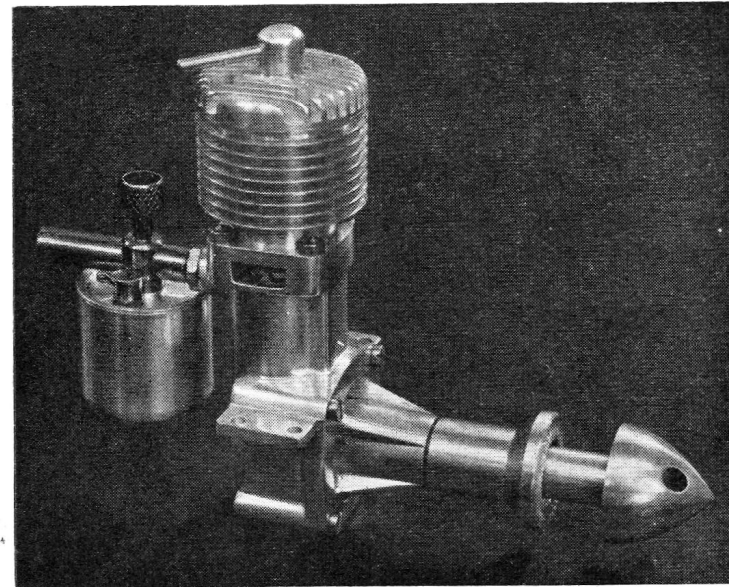

Fig. 21—The "Wildcat" diesel can also be used as a glow plug engine after being well run in and freed up with larger running clearances. A special head is used.

This is created by a space at the lower end of the large exhaust port which remains open when the piston is at the top of its stroke. The space is then between the skirt of the piston and the bottom of the port. It allows extra air to get into the crankcase, or in other words assists "breathing". Naturally, a richer mixture for starting than normal can be given. The makers' recommended fuel for the glow plug version is Methanol 3 parts, Castor Oil 1 part. The makers claim that the engine is capable of 9,000 r.p.m. with airscrew fitted.

The propeller is 10 in. diameter. There is an exceptionally long crankshaft, which keeps the owner's operating fingers comfortably out of the way of the revolving air-

screw when adjusting the fuel needle valve. This long shaft also makes a long streamlined nose on a model aircraft simple to attain. The tank is made of metal and is suitably large for the extra consumption of glow plug fuel.

Another dual purpose diesel-cum-glow-plug engine is the 5 c.c. WILDCAT made by Davies-Charlton & Coy. They state that considerable experience has been gained on the glow plug version of their engine. This firm also

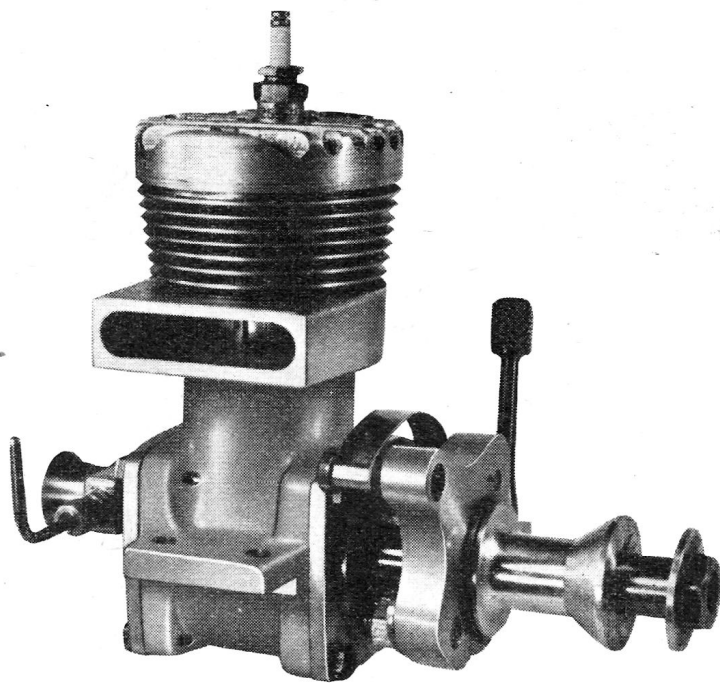

Fig. 22—The British "Rowell Racing 60" ball bearing high efficiency engine of 10 c.c. is also supplied as a glow plug engine with plain front housing. This engine has been officially timed at 85.4 m.p.h. in a model car.

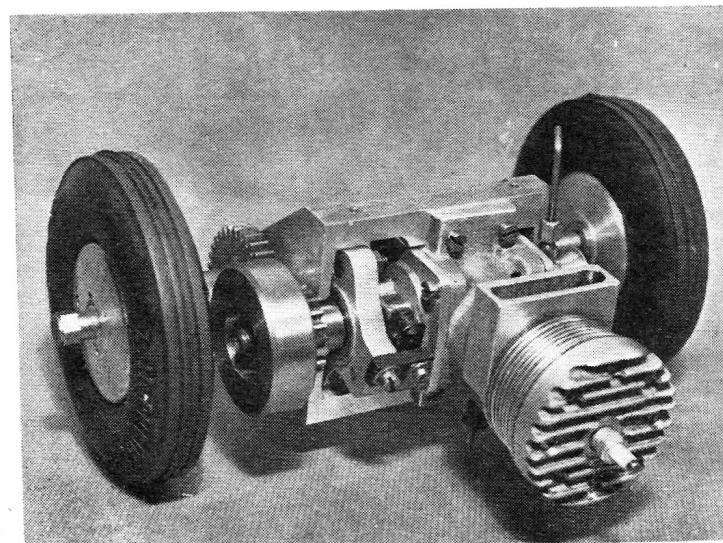

Fig. 23—The Rowell Racing "60" is also produced as a spur gear unit ready to bolt into a model car.

state: "As expected, best results are obtained after the engine has been first run as a diesel for some time. This is due to the fact that it runs much hotter than as a diesel and therefore requires larger running clearances. We advise all modellers to run their engines as diesels in the first instance, and to fit a glow plug head after a few hours total running". This firm also advise the use of "Mercury" Glow Plug Fuel.

Rowell Motors of Dundee make a large capacity 10 c.c. motor called the ROWELL 60. This engine is reminiscent of American ten c.c. class practice, and has been operated as a glow plug engine. The engine has put up an officially timed speed of 85.4 m.p.h. in a model car. Fig. 22 shows the motor with spark plug contact breaker gear, but it is also supplied with a plain front housing for glow plug ignition.



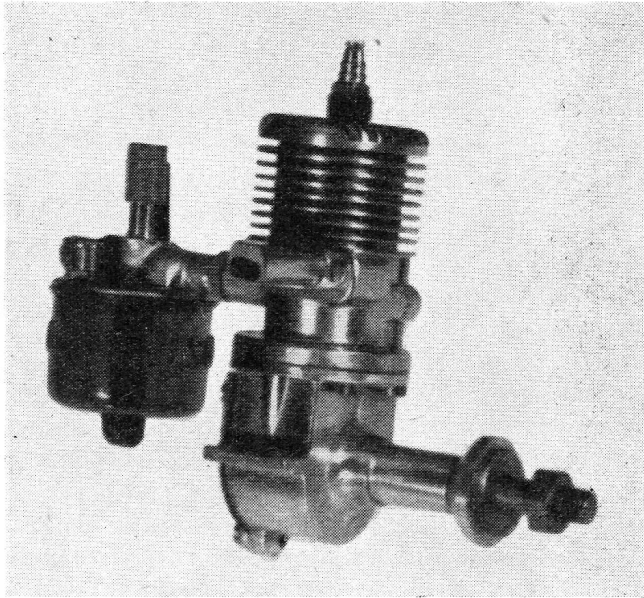

Fig. 24—The 4.5 c.c. "Majesco" engine makes an excellent medium powered glow plug engine when fitted with a McCoy plug.

The weight is 17 oz., and the compression ratio is 12 to 1. The Rowell motor has been designed "with one aim in view—ultimate performance as a racing engine". Piston rings are fitted and a rotary inlet valve is employed. A ball bearing crankshaft is fitted. A methanol fuel mixture is used in the engine, whether it is employed as a glow plug engine or a spark ignition motor. The manufacturers also make an interesting spur gear unit for model car work. It is the first high duty power-transmission spur geared unit to be made this side of the Atlantic, and is ready to be bolted into any constructor's car chassis.

The well known and well tried MAJESCO 4.5 c.c. petrol engine has recently been redesigned for glow plug

ignition, which gives a medium capacity engine the advantage of lighter weight. This engine is fitted to one of my model aircraft and has an excellent performance combined with its usual features of reliability and easy starting characteristics. The engine also makes an excellent

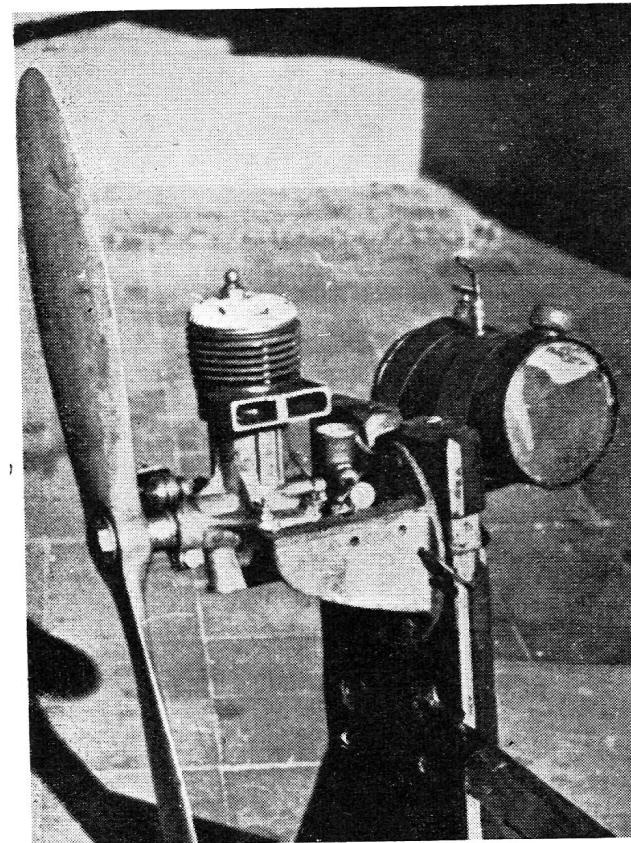

Fig. 25—The 10 c.c. American Atwood Champion is seen here. The twin rotary inlet ports will be noted. The latest glow plug engine is called the "Glo-Devil."

medium sized speed boat power unit for the planing type of craft such as my "FLYING FISH" hull seen in the last chapter. The McCoy glow plug is best suited to the engine.

The American ATWOOD Engines were designed by that well known designer Bill Atwood who was responsible for the original 6 c.c. "Baby Cyclone" which set a new standard in small size internal combustion engines many years ago in the early days of model power flying.

The ATWOOD CHAMPION has twin inlet ports via rotary valves. These are situated at the front of the engine and also at the rear. If the reader will refer to Fig. 25 he will see a photograph I took of this 10 c.c. engine. I now operate the engine on glow plug ignition. The makers produce a special model called the GLO-DEVIL (Model D.R.) with a .624 displacement. The compression ratio is 8 to 1. It is similar to the engine shown, except for the rear induction inlet orifice which has been modified. Twin inlet rotary valves are retained.

Bill Atwood has also recently produced two new engines of high efficiency called the TRIUMPH 49 and the TRIUMPH 51: both are suitable for glow plug ignition.

Atwood has a long history of obtaining great power from engines of the larger range capacity.

In America, the land of high speed records in the 10 c.c. class, the DOOLING has gained a tremendous reputation. Records have fallen to models in the car, the aeroplane and boat fields, with DOOLING engines installed. In Britain, where a few DOOLING engines have filtered in, Mr. Stone of the Malden Club used a DOOLING with a McCoy "Hot-Point" glow plug when he broke the British Hydroplane Record with a speed of 58.44 m.p.h. This is a great speed for water in this country and faster than the best speed put up by engines of 30 c.c. I am showing a DOOLING engine in Fig. 26. This has a spark plug fitted with its contact breaker gear. But Mr. Dooling tells me that this

engine is used for glow plug work with a cylinder head providing a slightly higher compression ratio, and of course the contact breaker gear is removed. He has some interesting remarks to make in regard to this particular engine which contrary to general procedure does not provide quite so much power with glow plug ignition as with timed spark ignition. On the other hand there is the lesser weight to consider. I will quote his remarks which I feel sure will interest readers, for they affect such an outstanding power producer in the large class.

"When Nitro-methane is available the performance of the DOOLING 61 engine with a glow plug is excellent and gives approximately 95% of the power with a standard ignition system. If nitro-methane is not available (for the DOOLING) then it would be better to retain the ignition system for highest performance *unless it be for an aeroplane*. It will be necessary to decide whether the loss in power is offset by the saving in weight. One possible source of supply for nitro-methane in your country is the large photographic film manufacturing companies".

The DOOLING 61 appears to run a little too cool to obtain the ultimate in power from glow plug ignition. This has been suggested by the fact that when the starter battery was kept in circuit and the plug's temperature kept high, the power loss, slight though it is, was restored. As a result a special glow plug head is being manufactured for DOOLING engines. In spite of this very small loss in power we should remember that a DOOLING engine has created the fastest time in a hydroplane in this country!

On the other side of the picture of "hot" 10 c.c. engines the American BUNGAY 600 engine claims a free speed of over 26,000 r.p.m. and enhanced performance with glow plug.

The DOOLING weighs 14 oz., and has roller bearing connecting rod and ball bearing mainshaft with rotary disc induction valve. The bore is 1.015 in., stroke 0.750 in.

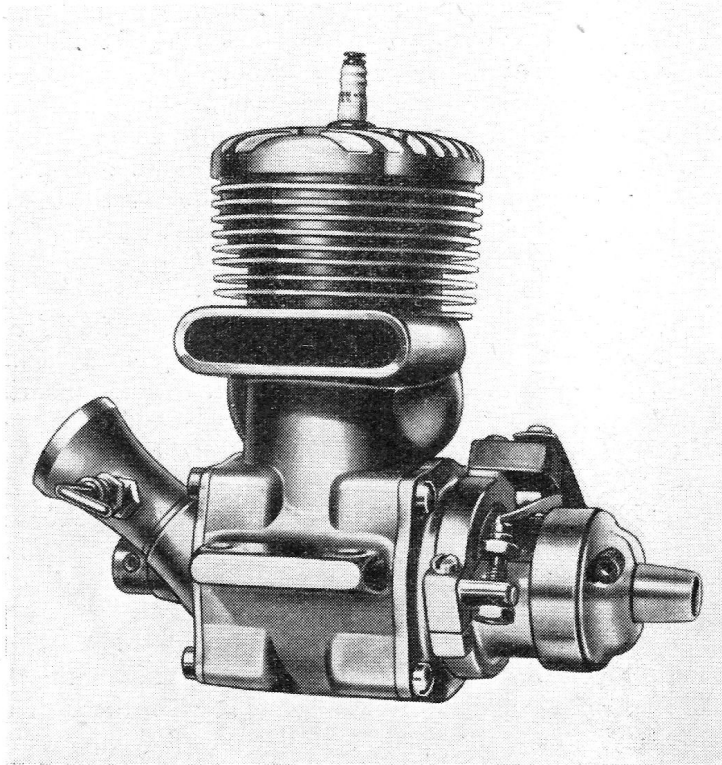

*Fig. 26—The 10 c.c. "Dooling 61" has a long line of high speed successes in the model car, boat and plane fields. The glow plug version has the contact breaker removed and a slightly raised compression ratio.*

The manufacturers claim that no known engine of any size or manufacture—even the finest full scale aircraft engines—compare with this engine in horse power per pound weight. Its history would appear to bear out this claim at the moment of writing. It is interesting to note that the DOOLING was produced after manufacturing 42 different engines—thirty-three of which were of original designs and nine were rebuilt from previous models. Of

the unusual types, there were several with rotary valves in the head, rotary discs, rotary sleeves, tube rotaries, step pistons and inverted pistons. One was a twin cylinder engine with rotary valves and dual ignition, and two were equipped with superchargers, one operating at 80,000 r.p.m. ! The "61" was finally decided upon for the average hobbyist. A special dynamometer was one of the most important pieces of laboratory apparatus in the development of the engine. It indicates horsepower to three decimal places.

This short story shows the reader unversed with model engine production, what effort goes into producing the engine of his choice. All successful manufacturers go through the mill !

## CHAPTER FOUR

*Operational Hints for Glow Plug Engines.**High Revolutions are Important.*

Although the above fact has been mentioned before, my readers will doubtless forgive a certain amount of repetition when I emphasise and explain the very vital importance of this characteristic of the glow plug engine. The successful operation of the type is so much bound up with the capability of high revolutions. This not only applies to the type of work given to the engine, but *it affects the propeller, and the engine's design generally*. For instance if we fit a propeller that holds down the high revving properties of the engine, the performance of the engine can never be satisfactory.

If the glow plug engine has a tight fitting bearing or a tight piston, then it will not be able to attain high revolutions. If the porting is constricted the engine cannot take in gas sufficiently quickly for high revolutions, nor can these revolutions be attained if the exhaust cannot get away sufficiently rapidly. An engine may have excellent porting of an ample nature and yet the transfer port can be on the small size, and will undo all the good that a suitable inlet port can give. Designers of the past in this country have always had a tendency on model engines to restrict power output by providing too small porting. Mr. Rankine, the speed boat enthusiast, surprised the model world some years ago by fitting enormous porting to his record-breaking boat engines. The Americans have developed vast ports for some considerable time and yet retained easy starting. It is good to see British manufacturers are now getting down to the virtues of large porting where motors require high revolutions. And our glow plug engines require this feature more than any other

type. In fact they demand it if they are to be a success.

Some readers used to the old slow speed but quite powerful spark ignition engines which they may have operated, think that a glow plug engine should give equal performance at low revolutions. This cannot be so, and we had better marshal our facts, so that we know how to treat our glow plug engines. This high speed characteristic is one of the greatest reasons why some ancient petrol engines with design features that do not permit high revolutions, do not make satisfactory glow plug conversions.

In the case of the spark plug engine, the designer times his spark to occur either early or late, in relation to where the piston is situated near the top of its stroke. Thus, if the spark ignites the gas before the piston comes to the top of the power stroke at T.D.C., the engine will run fast at high revolutions, provided the ports, etc., will allow this.

If the spark is timed to take place after the piston has passed the top of its stroke the ignited gases will give a belated push and the engine will run slowly. There will then be no tendency to knock. If the engine is starting up, or is pulling slowly at low revolutions, and the ignition takes place early, one of two things will occur, unless, of course, the compression ratio is very low. The piston will get a kick back before it has got to the top of its stroke. This may make it reverse the motor's direction of rotation. Readers will know how their engines (petrol) often kick back on starting if they have not retarded the ignition.

If the engine has already started and is running slowly, as described with ignition too far advanced, it will be pulled up in speed through the difficulty with which the piston has to overcome the pressure of the too early blow from the "explosion". As soon as the piston gets over top dead centre it is free to race ahead. In these circumstances the engine runs with a laboured feeling and dead exhaust note. It often knocks, and it certainly knocks its bearings to pieces if this procedure is persisted in.

The glow plug engine has what is in effect permanently early ignition, because as we have already remarked in a previous chapter, there is a glowing plug awaiting the upcoming piston.

*In these circumstances, the engine must be going fast to overcome the early ignition, just as in the case of a timed spark ignition petrol motor with ignition advanced.*

That is the whole crux of the matter, and the reason why the glow plug engine must be allowed to rev. The engine must then be given a task in the right type of model that will allow it to rev. It must be given a propeller that will allow it to rev. It must be provided with large ports that will allow it to rev. And it must be "free" in rotation, so that it can rev.

In the chapter showing glow plug engines, I have touched on ball races for easy turning, easy fitting pistons and bearings, but without undue leaks, past those bearings and pistons. I need not go into more technical details other than to remark that a glow plug engine will often run at its best with a really "sloppy" piston fit, provided the fit is just sufficient to keep reasonable compression. A diesel on the other hand must have a very close fitting piston. Readers must not judge the two types as one problem. It often happens that a new comer to glow plug operation is not satisfied with his new engine's output. If he would just run it in properly and really free it up all would be well, and his grouse maybe change to a paean of praise.

It should be evident that for a new power modeller to fit a glow plug engine, which has this revving at high speed characteristic to a model that requires a slow speed pulling type of power, is as silly as to enter a donkey for the Derby.

*Fuel tank design for high speed control line models, also boats and cars on the circular course—where centrifugal force affects fuel mixture strength.*

A model which flies around a fixed centre, or a car or

boat which travels around a fixed pole on the end of a line, which is the normal racing procedure, will never keep its engine running satisfactorily throughout its run unless a special fuel tank is fitted.

Furthermore, because the glow plug engine is particu-

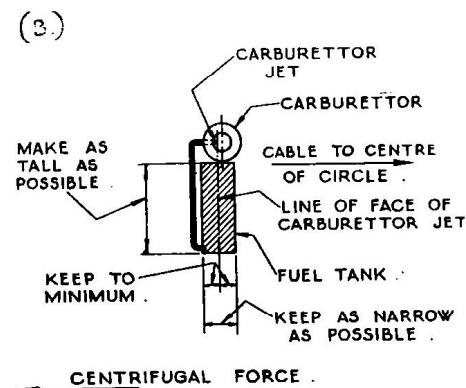
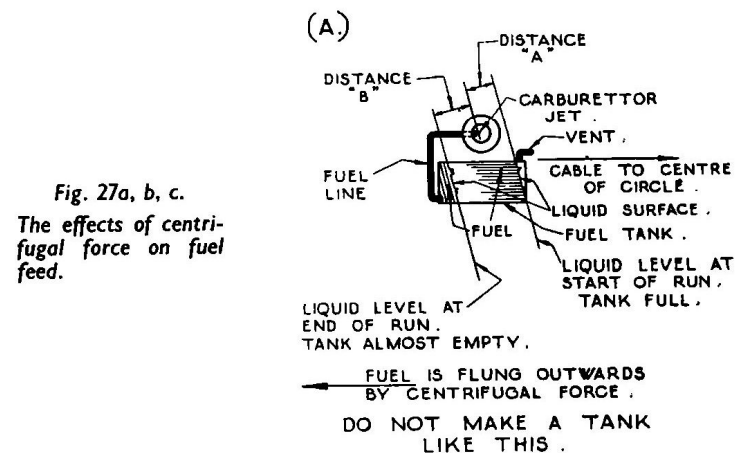

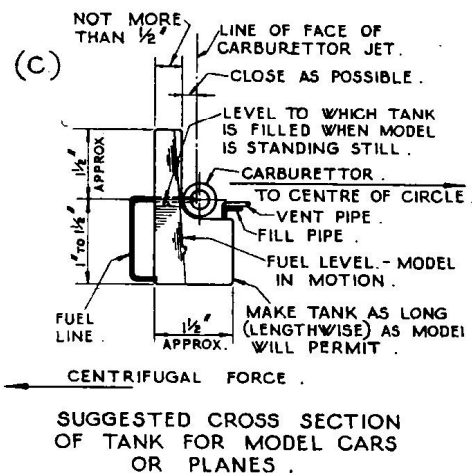

Fig. 27c.

larly touchy over mixture strength, and a rich mixture will over-cool the glowing element, the correct fuel tank is absolutely vital in these circumstances.

I must admit that I have very seldom seen even the stars amongst the stunt control line men in this country flying their large petrol engines for lap after lap running at top revolutions with perfectly consistent firing. There are usually signs of starving, hunting, or rich mixture during the flight. I believe that one of the reasons why the Americans to date hold all the ultimate speed records in aeroplane car and boat field in the model world, is due to the fact that their top liners ensure that the engine gets an even fuel flow throughout the run in spite of the very adverse effects of varying and mounting centrifugal force. How often one sees even at International boat meetings in Britain, erratic running amongst the better men. And yet if their engines were put on the bench they would roar the tank of fuel out without any falling off of speed. At the pond side the report often is, that "Mr. So-and-So got in a few laps at very high speed before bad luck set in and the

motor faded out". It was generally not due to bad luck. It was an unsuitable fuel tank! If you are a betting man and keen to know who will take off the first prize, have a look at the well-known boats and make a special note of those which have fuel arrangements likely to give an even mixture throughout the run as the speed rises.

Fig. 27 (A) shows how the fuel is flung to the outside of the circle and the outside of the tank. *As the model accelerates the fuel will also go backwards as well as outwards.*

If the tank is full at the start of the run or flight, the fuel will have a "head" of liquid equivalent to the distance "A" trying to force itself into the carburettor jet. When the tank empties as the run or flight continues the "head" of fuel will be as shown at "B".

*Therefore at the beginning of the run the carburettor has "forced feed" and at the end "suction feed."*

This causes the engine to get a rich mixture at the start of the speed run and weak at the end, which is a hopeless state of affairs for consistent power output. Incidentally the average model man makes himself a large flat tank or a large circular tank as shown in the sketch, when he requires a long run by a thirsty engine. He thinks that because he has placed the fuel pick up pipe in the far rear corner he has defeated centrifugal force worries, and if he also leads his pipe line away from the far corner he will overcome surge. He has only mitigated some of the worst of his trouble. He is annoyed because his "hot" engine fades out or misfires, often blaming the manufacturer for an overheating engine, etc. In actual fact he should blame his fuel feed. It is best in these circumstances to take the engine to the bench and if it will roar away well, then rethink out the tank problem! There are of course some canny racing men who have this all set, but I am discussing the average man.

The American Dooling firm explain how, as the speed rises, the centrifugal force creates even more trouble than

the sketch indicates. For the sake of argument, let it be supposed that Distance "A" equals one inch, and Distance "B" also equals one inch. The fuel level will then change 2 ins. during the model's run.

Let us assume that the model is travelling at 100 m.p.h. on a 35 foot radius. This means that due to centrifugal force the effect of the change of "head" from start to finish of the run is approximately 19 times as much as the actual measurement originally given! This would be the same as running the engine on the bench with a fuel tank 38 in. high, with the fuel level 19 in. above the carburetter at the start and 19 in. below the carburetter at the end of the run!

Can any reasonable man expect his poor engine to give of its reliable best without a misfire from beginning to end of the run under these circumstances, without altering his needle valve to compensate?

As our racing aspirant cannot get at his needle valve to alter it once the model is in motion, he must fit a tank that will defeat centrifugal force. What can he do to improve his tank? Fig. 27 (B) gives a clue. A deep narrow tank, fitted below the jet is a good method. In Fig. 27 (C) a sketch shows the principle upon which the racing Dooling tank is made. This tank can be made in a long narrow L shape where a large amount of fuel has to be carried. It seems to work well in practice, for last year the Dooling car created the world's car record of 127 m.p.h., and an aeroplane fitted with a Dooling engine created a propeller-driven model aircraft record of 143.8 m.p.h.

#### *Propellers for glow plug engines.*

It should be evident, from the remarks in previous chapters and at the beginning of this chapter, that modellers and manufacturers should fit propellers suitable for high revolutions to glow plug engines. These engines cannot give real results if a normal diameter and pitch propeller as fitted to the slower revving diesel is fitted.

The diameter should be less. The pitch must of course suit the speed of the model, but may, generally speaking, be a little lower than standard.

Most modellers know by now that a propeller or airscrew for aeroplanes is like a revolving aerofoil or wing. It is set at an angle of incidence to its line of forward travel, and it screws its way through the air or water. If the model is travelling fast then the pitch is increased.

If the machine is travelling slowly the pitch is less, because the blades do not go as far in one revolution as when the model is going faster.

A large area wing travels slowly, whereas a small heavily loaded wing travels fast. As our glow plug engine is rotating its propeller fast, the propeller wing or blade must also travel fast. We must therefore fit a small, fast travelling, highly loaded blade, i.e. a small diameter propeller that encourages high revolutions. One must of course be careful not to fit too small a blade area so that the propeller just buzzes around at terrific revolutions and either stalls itself hopelessly in the air, or cavitates in the water.

As a very rough guide I would recommend that glow plug engines are given a propeller with a diameter 1 in. to  $1\frac{1}{2}$  in. less than their diesel brothers, with a pitch to suit the speed of the model.

A free flight model travelling comparatively slowly will be best suited by a low pitch propeller. A speed control line model will require a high pitch propeller. A stunt control line model will require a slightly less pitched propeller than the speed model, because although fast, there are a number of occasions when the model loses speed at the top of a loop, etc., and *it is just at that moment* when the propeller must grip the air and keep pulling. Too high a pitch therefore will fail at the critical moment and does not encourage acceleration quickly after a stunt has been performed, ready for the next. The man who throws one stunt quickly after the other is the man who is

worth watching! Colonel Taplin's son used a  $7\frac{1}{2}$  in. diam. propeller with a pitch of 14 in. to create his British Class II speed record of 89-95 m.p.h. This meritorious performance, which amazed many modellers, and appeared to annoy others unable to make the grade themselves, judging by their letters to the Model press, was done with a diesel of only 2 c.c., which ran at 7,000 r.p.m. static and probably did 10,000 r.p.m. in the air. This speed from a diesel is above average of course, and a glow plug motor that pulled off a similar performance would probably do a greater number of maximum revs. in the air. It would therefore require a slightly lower pitch, for it would make more revolutions per foot of travel.

To obtain a racing speed like this means that the first few laps are very sluggish until the speed is built up and the revs gained with propeller gripping the air properly. That is why I mentioned that a quickly accelerating stunt machine must have a lower pitch, but not as low as a slow free flight model. A stunt machine is usually well served by a pitch of approximately 8 in. A glow plug motor with its high revolutions will probably give of its best with a pitch of 7 in. or even 6 in. Those are the general figures I have found from experience to be best. Naturally, an engine like the Arden glow plug motor which develops its power at exceptionally high revolutions will take a lowish pitch. If the reader will turn up the description of this engine in Chapter III he will note that the standard pitches given by the firm appear lower than normal.

We know from much practical experience, the best pitches and diameters that suit varying models and jobs, for water work or in the air. The theorist from his armchair will seldom get you a pitch and diameter that will win you a competition. There are too many variables in every model. There is drag for instance.

One model has a wing section that causes more drag than another. One model flies at a flatter angle than

another, and therefore flies faster. Fuselage shape alters the picture in every case. My advice is to set out with your model with a known average pitch and diameter propeller that suits this size of model and the type of engine. Then try slight variations either way, if you are determined to get ultimate performance, until you get the best results. If you just fly for fun then an average prop. will do. But also remember that you can ruin a model's flight or run on the water by fitting a propeller that gives excessive drag in the blades, which will unduly tend to turn the model over, and which in turn makes it fly one wing down and lose climb as a result, in spite of all the power the motor is handing out.

I defy the theorist to provide a winning propeller from pure armchair theory calculations. He will only get near the result, and if he ever does provide a winner, it will be more by good luck than calculation. Because of all the variables in every machine, he can only get near the answer. If you do not believe this, just fit a "hot" engine into a hydroplane and try slight bending of the propeller blades (they must, of course, be made to permit this), and you will be staggered at the different results you will obtain between runs, that a very small alteration of pitch will give. Now try the same propeller on another hydroplane with the same engine, and although the hydroplane may be of the same general dimensions regarding planing surfaces, the propeller will assuredly require alteration. The fact is that even the "full size" designers will produce theoretically correct propellers, and yet find that slight alterations very often improve speed on the boat, the propeller was designed for. I have spent more money than I like to think about on speed boats in this way.

Fortunately in the model world today we have so much experience of certain types and sizes of model aircraft that we have a very shrewd idea of the propeller that will give a *reasonable* performance for any particular model. But if



ultimate climb or speed is the goal, then a little *practical* trial, and error will have to take place, in spite of all the theory man's most abstruse calculations!

Wide blades with square tips suit free flight and stunt models. Thin, narrow blades generally suit high speed models. To give the reader some idea of the rapid advance in models, I can remember that when I flew the first power model to put up a long free flight record after World War I, there was no available data with regard to propellers for such a small model! Now we have a very complete starting off ground for any particular size power model, and my beard is not yet too long and grey.

Unfortunately, the pitches given by various manufacturers do not always tally with the actual pitch of their



Fig. 28—This 45½" span model, the "Meteorite", designed by the author as a kit model, demonstrates the importance of fitting a small diameter, low pitch, high revving propeller for free flight when using a glow plug engine.

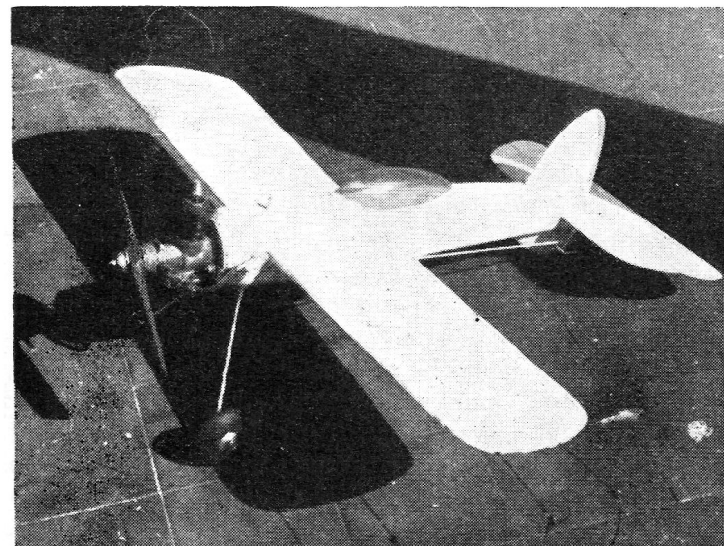

Fig. 29—This little stunt model by the author emphasises the importance of the small, high pitched propeller for control line work. The engine is an Arden .099.

propellers. This may rather confuse a keen model man, who finds that a particular advertised propeller does not come up to the performance he is led to expect. Furthermore, there are some terrible propellers on the market which provide the maximum of drag through the poor contour or section of their blades. Such drag will turn

#### GUIDE TO GLOW PLUG ENGINE PROPELLORS

C.C. Engine	Diam.	Pitch Free Flight	Pitch Control Line
1½ to 1¾	7½" to 8"	5"	6" to 7"
2 to 3	8½" to 9"	5" to 6"	7" to 8"
4-5	10½"	6"	7" to 8"
9 to 10	12" to 14"	6" to 7"	7" to 9"

over in the air quite a stable model, due to excessive torque, thus leading some people to believe, quite unfairly, that a certain model may be laterally unstable. It therefore behoves modellers to buy well-known makes of propeller with a reputation for accuracy.

*Swinging and Positioning the Propeller.*

Once the technique of starting has been mastered, *the glow plug engine is very easy to start.* This is made far more simple if the propeller is positioned in the correct place in relation to the engine's t.d.c. and compression.

The propeller should be positioned and tightened on the shaft so that it is coming on to compression near the top of its swing. The operator can then swing the blade right over compression and follow through with that flick of the wrist which gives *power and speed* that is so necessary to obtain good starting. A glow plug engine must have a really vicious swing because it has the "early ignition" characteristic that I have already explained, and is therefore like starting a car with fully advanced ignition. In the case of the car one may possibly break one's wrist unless a quick and determined swing is made under these circumstances. The correct way, of course, is to retard the ignition, but as explained, we cannot do this in the case of the glow plug engine. In any case, the model glow plug engine is so small that it cannot break the wrist, but it can give you a sharp rap over the knuckles! A glove is a sound fitment for the larger engines.

A properly positioned propeller with good flywheel effect due to sufficient weight gets over the trouble, if a good hearty swing is given.

If the model aircraft is a control line one which drops its undercarriage on take off, and therefore subsequently lands upon its belly, the propeller must be tightened up on its shaft so that the compression is felt as the propeller blade arrives at a horizontal position. When the engine

stops, the propeller will then revolve until compression pulls it up in a horizontal position and the model can land upon its belly without damaging the propeller, especially if the model is flown over grass. I dislike flying models over tarmac in any case, for damage is often done to engines when a crash takes place as it is sure to do occasionally even in the case of the experts who stunt regularly. A cut engine, when upside down in inverted flight, is not always possible to deal with. This horizontal position of the propeller makes starting a little more difficult, because it restricts the free swing somewhat. Fig. 30 shows a model that I specially constructed for this purpose, in which the forward belly of the undercarriage is swept slightly down-

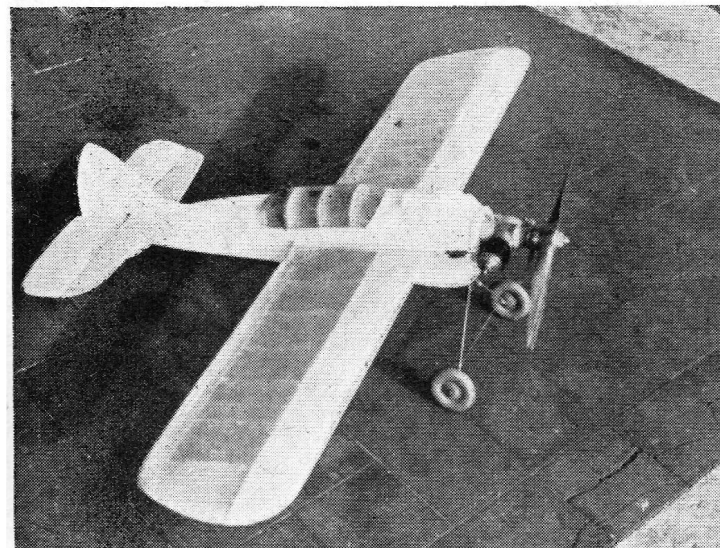

Fig. 30—This control line model drops its undercarriage after take-off. The propeller is so arranged that when the engine stops the propeller will be horizontal and ready for a "belly landing." Less drag and better stunting is the result.

wards to assist the landing. Such models must have a stunt tank fitted as already described.

Propellers for speed boats and water craft are discussed in my book, "Diesel Model Engines", which also deals with flywheels, etc., for model race cars.

*Converting an Existing "Petrol" Engine to Glow Plug Ignition.*

Many modellers will want to try out glow plug ignition on their old petrol motor before they invest in a specially designed glow plug motor. What are the chances of success, and what has to be done for this conversion? These are the usual questions asked.

Let me say first, that an old petrol engine will seldom give as good a performance as a specially designed glow plug engine, but there are exceptions to this rule, especially in the case of the more modern high efficiency petrol engines in the larger 10 c.c. class. Most petrol engines can be run with varying degrees of success as glow plug engines. Their efficiency depends upon a large number of factors which the reader will doubtless have weighed up after reading the foregoing chapters. I will therefore address my remarks to the newcomer to the type.

If the compression ratio is reasonably high, and porting is suitably large for fast work, and the plug not unduly shrouded, and a glow plug of the right type is fitted, also one of the special fuels mentioned is used, the old petrol motor should function well. Failings in any of the above factors will reduce the efficiency of results in proportion to the seriousness of the failing.

Some of the older petrol engines run so badly and roughly that the experimenter returns to spark ignition and its attendant weight with relief. On the other hand I have had most of my reasonably modern petrol engines running well on glow plug ignition. I cannot stress too strongly that the right plug to suit the engine makes all the difference, and if success is not obtained at first, try another

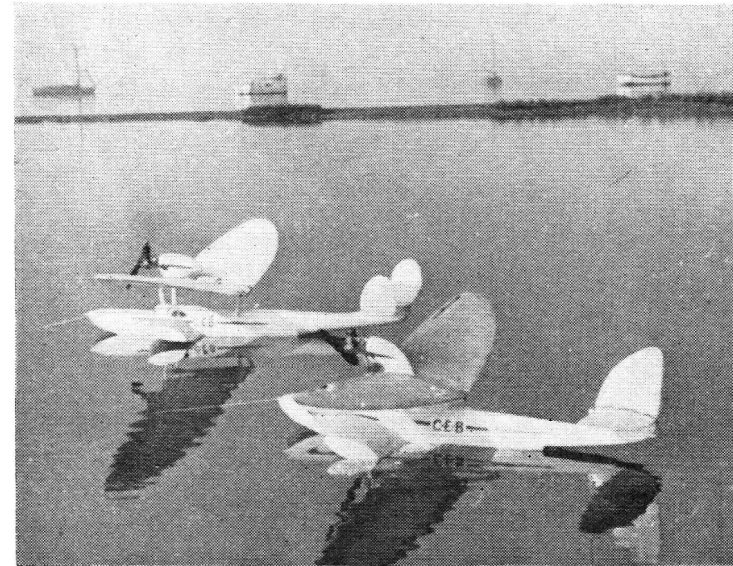

Fig. 31—These flying boats of the author's are flown by an "Ohlsson 60" and a "Majesco" 4.5 c.c. respectively.

plug of a different manufacture. There are only three plugs at the moment on the market, and so it does not financially wreck the experimenter to buy one of each for trial. Very often a long reach plug does the trick with lower compression engines.

If the engine will start, but fails to carry on running when the fuel mixture has been reasonably corrected by adjustment of the needle valve to a greater opening than usual, then try the long reach plug, taking care of course to check that it does not foul the piston at the top of its stroke. If there is any tendency to do this, a spare washer will cure the trouble.

Should the engine run quite well with starting accumulator disconnected after the start, but the power and speed of the engine does not seem to be as good as better than

in the days of spark ignition, then check up that the propeller is sufficiently small in diameter to allow high revolutions, and failing results *try a different make of plug*. Several of my old engines will start and run on a certain make of plug, but run at considerably greater power output on another make. This means that the element and the internal airspace in the particular plug suits the temperature created by the particular compression ratio of the engine.

When you have got your old motor running at its best, the next thing to do is to remove the contact breaker gear, for it creates useless friction, and the loss in power is greater than many people imagine. Some of the older contact breaker gears were not too clever in this respect.

Finally, do not ruin your celluloid tank. You may want to reconvert one day to "petroil" and spark ignition and want that tank! Make a metal tank, or buy a good commercial stunt tank. Make sure you mount it as described in this book.

#### *Mounting the Glow Plug Engine.*

This sounds a dull subject, but it is very noticeable how many people mount their expensive little engines on an absurdly flimsy mount that waves about in the breeze, vibrating horribly. These people often add to this outrage by not tightening up the propeller retaining nut properly.

#### *Vibration destroys good bearings and ruins smooth carburation.*

The fuel forms air bubbles which do not permit unimpeded fuel supply in the correct quantities as metered by the needle valve. It is a mere waste of time to take a lot of trouble getting your fuel setting correct if you ignore a rigid engine mount.

There are many methods of mounting an engine and I will not labour the point in this short book other than to remind readers of the absolutely vital necessity of

rigidly mounting the unit. It is unfair on the unit not to do this, for it was not designed to stand up to vast vibration not of its own making. This does not mean that you cannot make your engine and its mount detachable for the crash that a model aircraft is very likely to sustain sometime in its existence. A detachable mount secured by rubber bands makes the engine far less susceptible to damage. I can remember only damaging seriously one engine in my long life of power model flying which dates right back to the first post-war flight after World War I. I would personally never mount my aircraft engines on a purely rigid pair of arms built in one piece with the fuselage. It gives no protection to the crankshaft. I generally use my specially cast detachable mounts in Elektron. These are retained in position by rubber bands or springs, and form a rigid mount for the engine. They can be cowled or left open as desired, and can be detached in a moment. The mount permits packing with wood slips between fuselage and mount to alter thrust line and side thrust when tuning up the model.

A three-ply rigid, but detachable mount, can be made up on somewhat similar lines, and this and other mounts are described in my book, "Diesel Model Engines". The elektron mount casting, suitable for most engines after a little work with a file or hacksaw, can now be obtained from B.M. Models, 43, Westover Road, Bournemouth, for those who like the idea. Incidentally designs of models by myself of aeroplanes and speed boats, are also obtainable from this source.

The Dooling firm of America wisely say in their instruction sheets. "It is entirely possible for you to have the highest powered engine of all and yet throw away that power by improper installation. First, be sure that whatever you bolt the engine to (mounts) are flat. Do not bolt the engine down on a crooked surface as this will tend to put undue strain on the whole engine." Need I add that a rigid

yet detachable non-twisted mount is required for aeroplanes, and a rigid and flat mounting that cannot twist is essential for boats and cars.

*Do Not Dismantle Your Engine Unnecessarily.*

Again I borrow wise words from Dooling to bolster my remarks. The instruction books says: "Do not dismantle your engine unless absolutely necessary." This is printed in large black type. It is sound advice seldom taken by modellers, and also advice offered by many other model engine manufacturers. In fact, most cancel their guarantee when the engine has been dismantled. To dismantle his engine often seems to be one of the first operations to be undertaken by the new purchaser, "to see how it works."

Sometimes that most dangerous person, the "expert

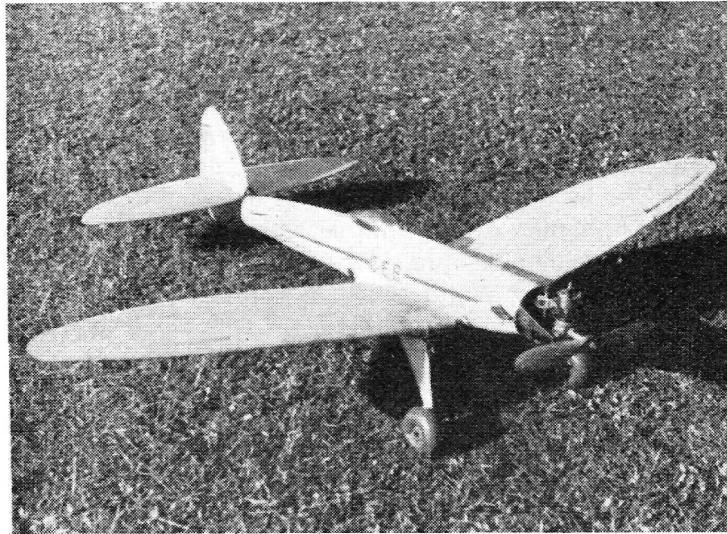

Fig. 32—The author's rigid yet detachable and knock-off-able engine mount is here fitted to his 4 foot 4 inch span monocoque model powered by a glow plug engine.

engineering friend," has a go. Much damage is often done by these fits of inquisitiveness. Often, if the owner cannot obtain a start because he has not the technique, he gets someone from a garage to dismantle the poor engine, which is sometimes treated like a tractor engine by the boy who sweeps up the floor. Fundamentally, model engines are the same, but practically very different, and they should be handled by people practised in stripping and erecting these small motors.

Normally a good two-stroke model engine should not require dismantling during its operating life. Many of my engines have never been opened up and yet have given many happy flights or much boat work over a long life.

A two-stroke engine runs better when the gas seals have been made by a little carbon. Tinkering disturbs these. So my advice is leave well alone unless you are experienced and dismantling is a form of pleasure that you must indulge in for your happiness, or unless your engine has a crash when something bends, or it takes in a mouthful of earth and grass. In the latter case this can often be cleared away from the orifices by some petrol and a brush without any foreign matter getting into the works, provided the engine is not rotated until it is clean. Rotating it sucks in the dirt.

*How to Stop the Glow Plug Engine.*

Glow plug ignition cannot be switched off like spark ignition. Therefore, the safest way is to stop the fuel supply. This can be done in three ways: (a) By fitting a small tank which will only supply fuel for a run of limited duration. This is satisfactory for sport flying but not for exact timing of competitions. It has the merit that the model cannot fly away. (b) Close the induction pipe so that mixture cannot be drawn in. A flap can be arranged to cover the intake orifice and is spring-controlled, being tripped by a time switch. There are various time switches on the market. The most usual are airhydraulic, but are not very accurate to

### PRINCIPLE OF FUEL CUT OFF TO STOP ENGINE RUNNING .

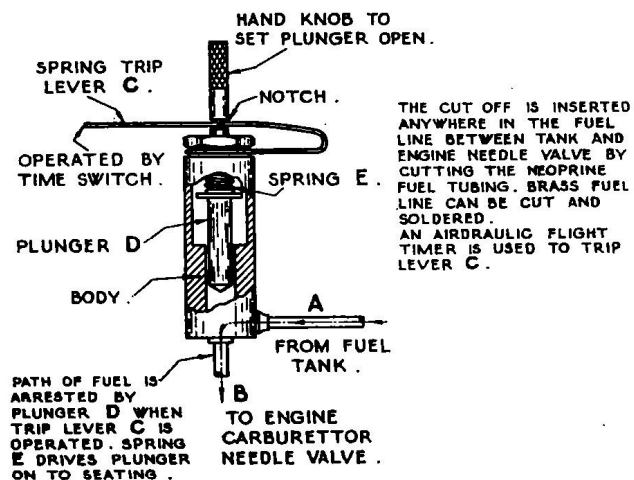

Fig. 33—The above is installed in the fuel pipe line, and forms a reasonably sure method of stopping a glow plug motor if a reliable time switch is fitted.

to within seconds. They are cheap and light. The best I have experienced is the "Elmic."

Camera clockwork timers if obtainable are accurate and useful. The closed flap method has been known to fail, because if the flap, which should have a rubber pad on it to prevent leaks, only half closes the engine runs on for a far longer time and the model is well and truly lost.

(c) Fit a fuel cut off in the fuel line operated by a time switch. This method is perhaps the best. It has the advantage of starving the engine for the last few revolutions to a stuttering standstill. This gradual stutter stop gives a model aeroplane time to put its nose into a good gliding angle. If an engine is stopped suddenly when in full cry

with the model's nose climbing to the stars, there is a tendency for the model to get into a series of stalls and a fugoid path, which is highly distressing for its owner to watch (see Fig. 36). Fig. 33 shows the principle of a fuel cut-off. The F.G. Fuel Shut Off Valve manufactured by F. Guest is on somewhat similar lines and is an excellent little instrument.

#### *Mechanical Starting for Large Capacity Engines.*

The "early ignition" effect of glow plug ignition makes starting the larger capacity "hot" high compression engines difficult because there is the tendency to kick back. In America many clubs have a communal mechanical starter rigged up from a car starter motor and battery. This is a luxury not often encountered in this now more austere country, but may well be more in evidence as the larger racing glow plug engines become popular over here, as they doubtless will do.

Sir Robert Bland Bird, the well-known vice-president of the Society of Model Aeronautical Engineers, and a very keen and resourceful model enthusiast, has a specially made mechanical electrical starter which can be used to start either aero propellers or a boat flywheel. There is a flexible speedometer-type drive with a chuck at the business end. This takes varying friction heads to suit the different tasks it has to deal with. Thus an airscrew has a large circular flat disc which grips the propeller blades, and a boat or car flywheel is gripped by a small driver disc. I have helped Sir Robert to start his 10 c.c. engine in a speed boat with this instrument, and later in the day to start up an air propeller. All the hard work is taken out of starting, but the job of carting about the heavy gear is no mean feat! The subject deserves a little careful thought when a modeller is going in seriously for racing engines having a large capacity and high compression.

Otherwise a stout glove and a heavyish propeller, allied to a fearless and vicious swing are the best remedy. For



Fig. 34—The author's "C" class three point suspension hydroplane is now run on glow plug ignition to lighten the planing load.

cars and boats a grooved flywheel with a leather belt of the round section type as supplied by the Singer Sewing Machine Company for their sewing machines is the best method of starting, other than by mechanical starter.

Fig. 34 shows a three-point suspension hydroplane which I fitted with a 14 c.c. ball-bearing Forster engine. Since taking this photograph I have run the engine on a glow plug and methanol fuel, thus cutting the weight of the old ignition gear and also lightening the water loading for faster planing. I use a leather thong to start this engine. Engine bearers must be really stout and of oak to withstand the heavy pull on the thong when starting up a large glow plug engine such as this. I use a McCoy long reach plug on this engine.

*Running in and Testing the Engine.*

Elsewhere I have emphasised the importance of obtaining a really free engine for glow plug work at its best. A little care is therefore well repaid over the running in period.

This work can conveniently be in two stages where an aeroplane is concerned. The first is on a test stand which can be rigged up on the bench or preferably out of doors where fumes are not troublesome. Care has to be taken with regard to adequate ventilation indoors.

A really large tank of noble proportions is useful for the test stand, but this must not be used to the bitter end when the engine is brand new. A series of short sharp runs are required. Later, long runs with a rather rich mixture are good, followed by a few full-power bursts. During the

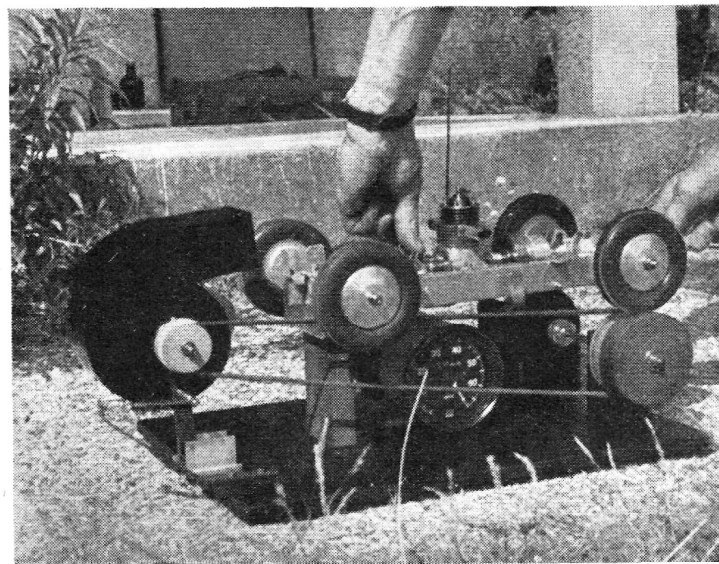

Fig. 35—Mr. Curwen's ingenious test machine records speeds under load of the fan brake driven from the friction discs rotated by the car's wheels.

running-in period I drip a few occasional drops of lubricating oil into the induction port from an oil can whilst the engine is running. Care must be taken not to overdo this for the sake of the plug, but it does help to provide adequate lubrication when working clearances are small and the engine tends to overheat and tighten up. A test stand made from odd pieces of wood can be seen in Fig. 25, Chapter III.

Fig. 35 shows a really scientific home test apparatus which Mr. Curwen, the well-known model race car enthusiast, uses when developing his engines. This enables him to run up his car chassis and take test readings of performance speeds including transmission losses. He is also able to make preliminary fuel mixture adjustments under load. A speedometer is fitted and the engine drives a combined fan and brake through friction discs and the wheels.

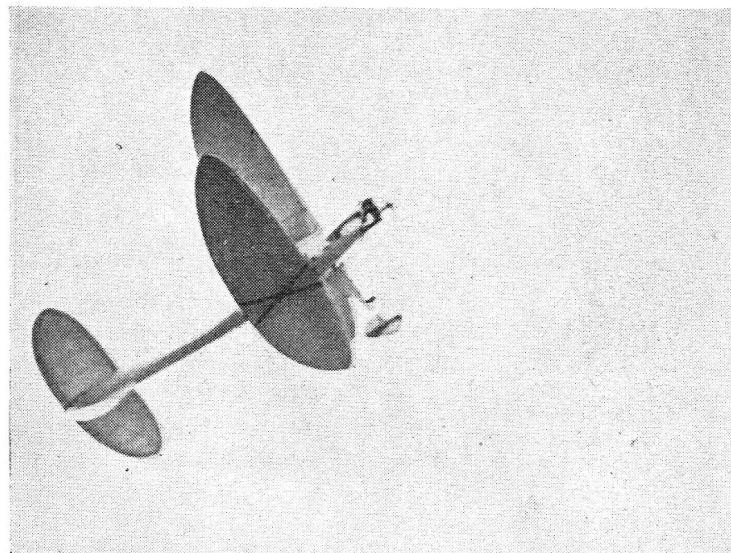

Fig. 36—Climbing to the stars by glow plug ignition. The model is a monoplane by the author.

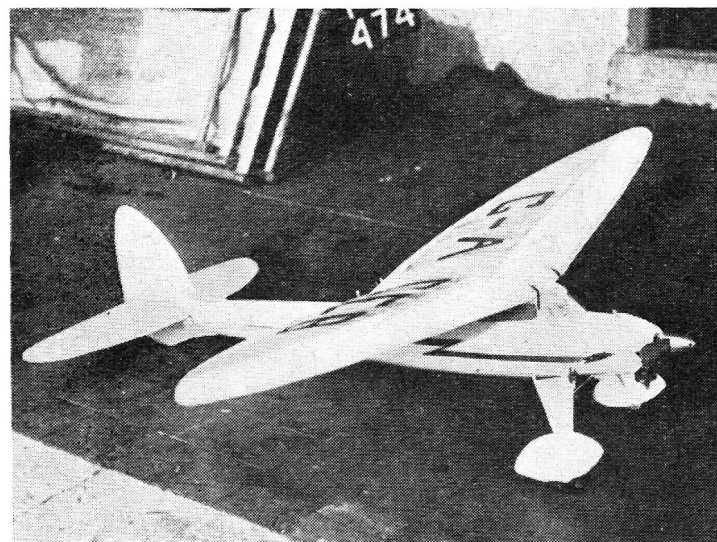

Fig. 37—The Bowden "Satellite", 48 inch span monoplane model keeps construction light and simple because of the glow plug engine.

The engine shown on the test rig is of extreme interest, for it is a combination of diesel-cum-glow plug engine, and is started by spark ignition when running as a diesel, with the power pack removed when the engine is started. The engine is only 5 c.c. and yet it has on numerous occasions been timed to do over 60 m.p.h. on the track. It also drives a model hydroplane. Mr. Curwen says the engine runs very well on a glow plug.

The second stage of running in for model aircraft is done on the ground with engine mounted in the model. This is a very important stage, which should not be shirked by the modeller keen to get his latest creation into the air. It is the stage when installation troubles appear, and it is when the owner gets to know his engine's starting under the much more difficult swinging conditions near the



ground. It is surprising how easy it is to swing an engine when it is comfortably situated at bench height.

*Simplicity is a Strong Feature.*

The glow plug engine is one of the best types to choose when building monocoque models with their nice streamline form. There is no need to consider the troublesome cutting of holes in the fuselage, or providing trapdoors for electrical ignition, battery, etc., which ruin appearance and reduce strength. This component can be an unbroken smooth shell, planked up direct and with only a few wire hooks protruding. On very small models the undercarriage can be just two spring steel cantilever wire legs. I find these bend too freely on models of 45-in. span and over.

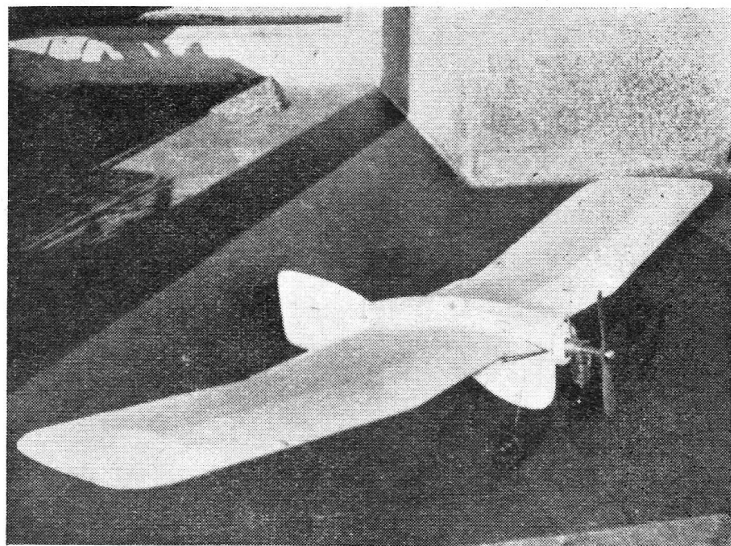

Fig. 38—The author's curious experimental "flying plank" model has no tail. Only a trim tab is fitted to the reflex wing section main plane. Strangely enough the model flies with considerable stability.

In this case I fit a rubber shock absorber undercarriage as seen in the photograph (Fig. 37) of my little monocoque high-wing 48 in. span "Bowden Satellite", designed for a kit model suitable for the Frog 160 glow plug engine and small diesels up to 2 c.c.

*Experimental Models.*

Experimental models afford the greatest fun and interest in model building, for they are a test of one's brain storms, and full of the unknown. Alterations can be carried out quickly when glow plug ignition is used, because the engine is merely clapped on to a plain fuselage without any wiring or other installation waste of time. A completely new fuselage if necessary is quickly built.

*Water Craft.*

The glow plug engine and its brother diesel are both power units particularly suited to model flying boats, float-planes and speed boats.

I have, perhaps, as much experience over the years of this branch of modelling as most people, for I have always taken a keen interest in the water and boats, combining model racing and full-size work. It is an extremely interesting and intriguing type of modelling, for there are dual problems to be tackled as well as the pleasant surroundings that water usually produces.

Electrical spark ignition has always complicated the designer's troubles, and spoilt many a day's fun due to electrical trouble after a ducking, or sea water spray and its corrosive effect on electrical equipment.

Now we have the simple diesel or glow plug engines which give no unnecessary trouble, and allow us to concentrate upon the model's performance. The starting battery for glow plug ignition does not give trouble, for it remains in the operating dinghy or upon the shore if the model is being launched at the pond side. The high-speed

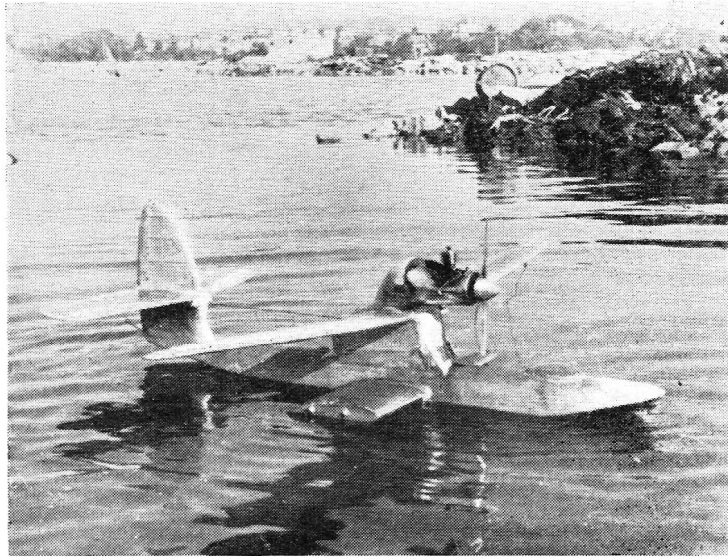

*Fig. 39—Try your hand at control line flying from water. It can be done from the bank or shore of a pond or the sea. This model is fitted with an E.D. glow plug engine, and was made by the author.*

glow plug engine is very suitable for planing speed boats and hydroplanes, and ideal for the larger flying boats and floatplanes where the diesel is not available in the larger capacity. The glow plug engine gives a light water and wing loading which makes all the difference when operating water model craft. Planing craft have a punch and potency that can never be obtained when loaded up with heavy batteries and coil ignition, etc.

The little diesel is very suitable for the baby water craft models, and the glow plug engine for the medium and larger craft. Models can be smaller and more portable when fitted with either of these engine types, but the size is naturally limited by the type of water they have to operate from. Open inland sea water or lakes can usually be relied

upon to have large "scale" waves even in good weather, compared to a sheltered pond. On the other hand, I think the sea water surroundings are more fun and give greater scope, especially if one has a boat or can beg or borrow one. In these circumstances the larger model is the best because it is always more stable and can cope with rough water better.

The man who is restricted to a pond and has aeroplane leanings can get a great deal of fun from control line flying off water. He has a half circle or more, if prepared to do a little wading, to take off the model. He then flies his aircraft overland for the remainder of the circle. This requires some nice judgment in take-off and landing. If the motor cuts when over land he merely has to give a slight "whip" of the wrist which carries the model on until a landing is made on the water. Believe me, this water

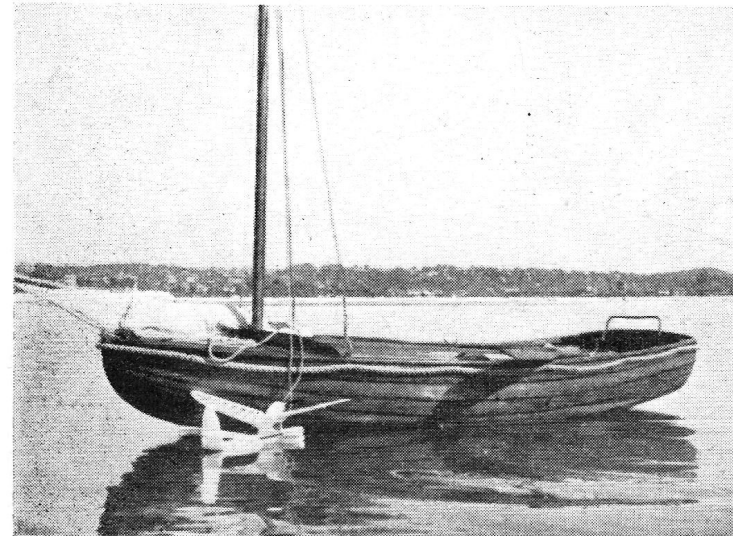

*Fig. 40—Peaceful surroundings with a flavour of model activity. The author's "Wee Sea Bee", seen beside the tender, is powered by a Frog "Red Glow 160."*

control lining cuts out any of the tediousness that land control line flying eventually produces.

The design of the model is not as simple as some people may imagine, for the weight of the lines and the inward pull, without the correcting friction of a wheeled under-carriage on land, tends to spoil the beginning of the take-off until the model has got into its stride. A specially long hull for a flying boat is required with a forward water rudder to overcome this. Fig. 39 shows a model I fly control line having these features. I have recently gone over to glow plug ignition on this model and, incidentally, in spare moments have been slowly compiling a book on this intriguing subject of working model water craft. This

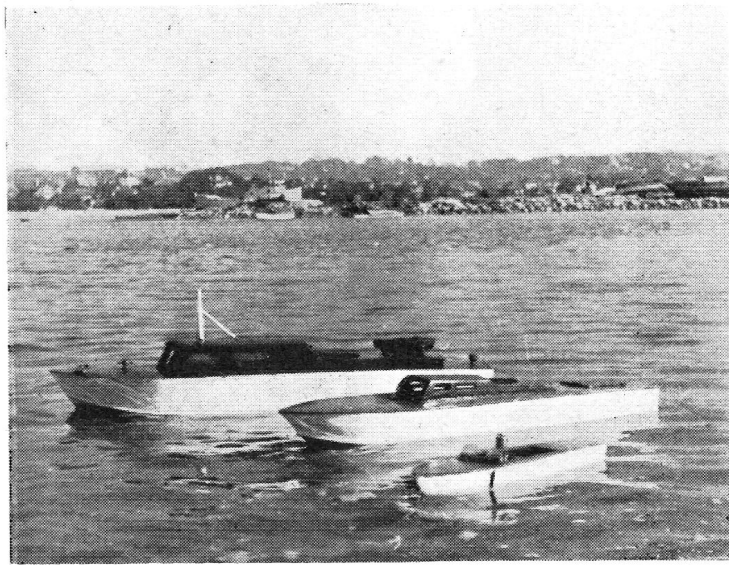

Fig. 41—A bevy of speed boats of the vee bottom, planing type. Foreground, the 19 inch "Sea Swallow"—1 c.c. Frog diesel. Centre, the 38 inch "Flying Fish"—4.5 c.c. Majesco glow plug engine. Rear, 44 inch "Swordfish"—Nordec 10 c.c.

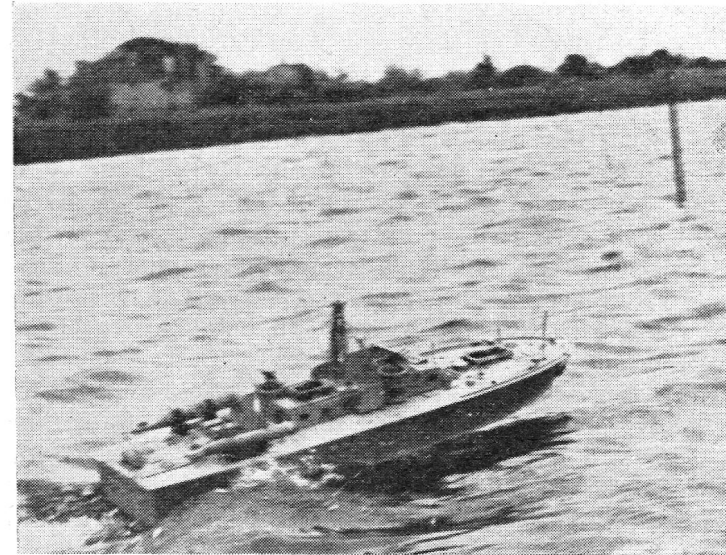

Fig. 42—Action on the water. High speed is just what the doctor ordered for glow plug ignition.

may be some time before it sees the light of day, but I have been fortunate in obtaining many wonderfully interesting photographs of foreign models from all over the world. It is surprising how backward we are in this country concerning flying water models, considering we are a maritime nation surrounded by the sea, and considering what fun there is in the type!

#### *Fault Finding Chart.*

There is not much likely to be wrong with glow plug ignition, whereas spark ignition used to be the main source of trouble to the average model man. It is, however, well to have a method in tracing troubles.

(1) *Engine will not start.* Plug has been checked and is seen through exhaust port to be glowing. Starting battery or accumulator is "up". Trouble probably due to oil

clogging the fuel line, and engine not sucking in fuel properly. Blow line clear and clean needle valve jet. If needle valve is taken out to clean, first make a note of how many turns it was open at the last run. When replacing, make sure that you GENTLY screw down until closed. Then open to "run position", or perhaps a shade more, choke and start. As engine is choked fuel can usually be seen on finger. If needle is forced the jet seating will be damaged. Some needles are soldered to a collar, and this solder has become unsweated. This will cause starting troubles. Resweat the needle with point on seating in "closed position".

(2) *Airscrew oscillates back and forth but engine does not start.* Usually when this happens a sizzling noise is heard and vapour will be seen at exhaust ports. This means you have sucked in too much fuel, and mixture is very rich. Close needle valve and swing to clear. The fuel will burn away. Then repeat starting procedure as from beginning and as described in this book.

(3) *Engine stops dead after starting.* Too much fuel has either caused plug to cool off, or a "fuel hydraulic lock" in extreme cases has filled the small space between cylinder head and piston at the top of the stroke. Shut off fuel by closing needle valve gently and, if necessary, turn engine upside down with exhaust port open and drain out fuel from cylinder. Now start again.

(4) *Engine starts and "four-strokes".* Even a novice can tell a four-stroking engine. There is not that quick even beat. There is a slower beat, more noisy but even, as opposed to misfiring which is irregular. In this case, the needle valve is slightly too far open and mixture is just too rich without actually being so rich as to stop the engine. Reduce needle valve opening slightly by turning clockwise which gives less fuel and more air.

(5) *Engine misfires and slows down, but does not stop dead.* The mixture is too weak. Slightly open up the needle valve

by turning anti-clockwise thereby unscrewing, until engine runs at maximum revolutions.

(6) *Engine vibrates unduly.* Engine may be loose on mount, or mount may be flimsy. Airscrew or flywheel may not be balanced. Test balance by placing on a rod and rotating. Propeller should stop at varying places after each rotational swing. If it always stops one blade down, that blade is too heavy. Sandpaper or reduce by filing, taking care that the offending blade is kept to its aerofoil shape. This is a common fault, and I have known even some moulded plastic propellers to be out of balance, although this is not normally expected, for they all come from the same mould. Unbalanced flywheels have to be drilled and lightened in the heavy part. A badly carved propeller with uneven blade contour can cause bad vibration. Vibration upsets fuel flow by causing bubbles in the fuel tank and line. It also very speedily ruins bearings. I recently had a new "full size" outboard motor from a famous firm which had undue vibration. I took it back to the firm who found the flywheel had somehow been fitted to the engine without being previously balanced. This had caused bad wear in the mainbearing in a very short period. As soon as the flywheel was drilled and balanced the motor ran like a little clock.

(7) *Engine is stiff to turn.* This often happens on glow plug engines on first starting for the day, because the sticky castor oil gums up the engine. Suck in liquid fuel for a few "choked" turns. This will wash away the gummy deposits. Now close the needle valve GENTLY and clear rich mixture away before starting by swinging. Then start up in the ordinary way.

(8) *Engine becomes damaged and out of true.* It will be difficult to turn at one point of its revolution. There may have been a crash, or even no crash, and yet damage may have occurred through a careless owner gripping the engine in a vice when testing instead of mounting properly to a

test stand or in the model. The vice squeezes and distorts the crankcase which is naturally not designed to be crushed. Some engines require cylinder holding down bolts (where these are fitted) to be taken up after they are run in when new. If these bolts are not tightened gently *and evenly*, they will cause the cylinder to draw up out of line and cause the piston to bind.

(9) *After a crash.* Make sure engine turns easily and quite freely. If it binds, the crankshaft has probably been bent. Send to makers. But before turning the engine to test for freeness, make sure that dirt and grit has not got into and blocked the intake or exhaust ports, because if there is dirt present it may be sucked into the engine when it is turned. In this case first clean dirt away and finish with petrol and a brush taking care no dirt is washed into the ports. If this is impossible, the engine must be dismantled without turning it. Before you do this make sure you know how to remake gasket joints, etc., and be careful to replace piston and cylinder in the correct way, or the piston deflector hump will not function.

(10) *Engine is bad starter and runner.* If plug O.K. and fuel correct, this is often due to air leaks past worn bearings, or badly fitted gaskets, or a worn piston. The makers are the best people to tackle this trouble except in regard to making new joints which is easily done by the owner. There must be good crankcase compression on a "two-stroke" for the engine to inhale its charge and to pump that charge into the cylinder via the transfer port. See Chapter I—How a two-stroke works. The piston must, therefore, be a sufficiently good fit and not blow too many bubbles when put on compression.

(11) *Loose propeller or flywheel.* This is a far more frequent fault with new owners than many people imagine. Make sure the propeller is kept tight and test frequently between runs. Be careful, however, not to use too large a spanner and force the nut or the thread can be stripped.

(12) *Plug will not glow.* This may be a burnt-out plug or a damaged element where it joins the plug body. Or an exhausted battery, or bad contact by crocodile clips to lug or "earth" may be the cause. Use good robust flexible leads of large diameter, for like a large bore water pipe, heavy duty leads pass the flow of current easily. Always have a new and known good plug handy to test the "dud plug" possibility by elimination as the first move.

#### PUBLISHER'S ANNOUNCEMENT

Readers of *Model Glow Plug Engines* will be interested to know that Colonel Bowden's *Diesel Model Engines* has been revised and brought right up to date. The book gives details of all the well-known British and foreign diesel engine designs. There are 192 pages and 119 illustrations. The price is 5/-.

R. H. Warring is no stranger to model aircraft fans. The publishers have commissioned him to write a series of three books on control line flying, entitled *Control Line Flying*, *Stunt Control Line Flying*, and *Speed Control Line Models*. The first two are now available and the third is in preparation.