

GLIDER MAINTENANCE MANUAL

5/-

R. C. STAFFORD-ALLEN

GLIDER MAINTENANCE MANUAL

A Manual approved by the British
Gliding Association Technical Committee

by

RAY C. STAFFORD-ALLEN

Manager and Ground Engineer of the
London Gliding Club

Published by

BRITISH GLIDING ASSOCIATION

Londonderry House

19 Park Lane, London, W.1

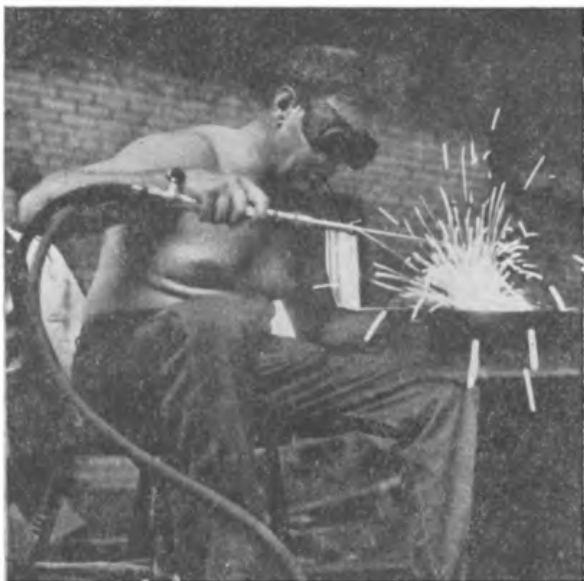

THE AUTHOR AT WORK

photo by T. Marshall

INTRODUCTION

THE aim of this manual is not to instruct the Approved Inspector how to repair gliders. He already knows this, otherwise he would not have obtained Approval. It is written for the purpose of helping private owners, and people operating Gliding Clubs in out of the way places, to keep their machines in a good state of airworthiness. It is hoped that it will also be found useful by the man who is hoping to get B.G.A. Approval for his work.

I am indebted to F. G. Irving and P. A. Slann who drew all the technical illustrations, and to C. O. Vernon for the preparation of the Chapter on the B.G.A. Airworthiness Scheme.

R. C. STAFFORD-ALLEN.

CONTENTS

	<i>page</i>
INTRODUCTION <i>by</i> R. C. Stafford-Allen	iii
FOREWORD <i>by</i> P. A. Wills	v
1. MAINTENANCE	1
2. REPAIRS. GENERAL CONSIDERATIONS	6
3. TIMBER AND PLY REPAIRS, GLUES	8
4. METAL REPAIRS	13
5. CONTROL SYSTEM AND CABLES, ETC.	15
6. FABRIC AND DOPE	18
7. TYPES OF CONSTRUCTION AND INSPECTION FOR DAMAGE	21
8. THE C. OF A. OVERHAUL AND WEIGHING OF GLIDERS	24
<i>Appendices</i>	
I. B.G.A. FORMS	27
II. A LIST OF USEFUL ADDRESSES	37
B.G.A. AIRWORTHINESS FEES	46
INDEX	39
<i>The B.G.A. Airworthiness Scheme by C. O. Vernon</i>	42

FOREWORD

ONE of the major attractions of gliding is that in most countries we are allowed pretty well to look after ourselves, with only the minimum of official control.

But this freedom brings with it responsibility. If we are allowed to maintain, repair, and even build our own aircraft, we must take care that we can do these things well; not only our own lives but those of others depend on it.

A difficulty facing us is this: that with the increasing technical complexity of powered craft, and the diminishing use in their construction of wood and plywood, which are our main materials, the number of professionals who can train us in the knowledge and techniques which we need is rapidly dwindling.

Thus it has become more and more important that we should get at least the minimum of information compiled in book form; and since such a book must be meticulously accurate its compilation is a laborious business.

But I now take it as axiomatic that, for any task however arduous or complicated, the gliding movement will somewhere produce exactly the right man. It has done it again. Ray Stafford-Allen's book will for years to come give the basic information eagerly required by owners and operators of gliders from Perranporth to Portmoak, from Wolloomooloo to Medicine Hat. It will save money, time, temper—and judging by one or two things I have sometimes seen going on in the wilder places of the world, even lives. Thank you, Ray.

P. A. WILLS,
Chairman,
British Gliding Association.

1.2.59.

SLINGSBY SAILPLANES LTD.
KIRBYMOORSIDE : YORKSHIRE : ENGLAND :

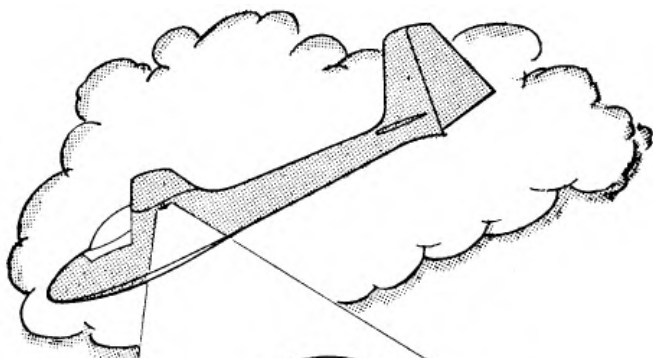

for
Slingsby
SKYLARK 3b.
PERFORMANCE
RELIABILITY

WRITE FOR BROCHURE
CADDT : PREFECT : SEDBERGH : SKYLARK 2 : EAGLE

REPAIR AND SPARE PARTS SERVICE

We hold extensive stocks of spares and modification kits for all our types of aircraft. Aircraft spruce, plywood, glue, paints, fabric, dopes, control cables, metal fittings, in fact everything for replacement or repairs to your aircraft. Advisory Service available for guidance on repairs, maintenance and modifications.

Tel. No.: KIRBYMOORSIDE 312 and 313

Grams: SAILPLANES

1. MAINTENANCE

WE may define Maintenance as work carried out on a glider to prevent deterioration, or to delay its effects, while repairs may be defined as operations to rectify damage. These two definitions are clearly not perfect since they do, in a sense, overlap. However, they are good enough for our purposes.

Let us deal with Maintenance first. However much money we lay out on the purchase of a brand new "Super-Heaven" sailplane, it will, from the moment we take delivery, begin to deteriorate. But, by taking a little thought, and putting in some work on it, we can keep that sailplane in virtually brand new condition. The first thing we must deal with is:—

Lubrication

It is more or less axiomatic that, where metal rubs on metal, some lubricant should be used to reduce friction and prevent wear. In the general structure and control system of gliders, the moving parts are all slow-moving, and for this purpose the best lubricant is a good quality grease. Unfortunately most manufacturers are rather stingy in the matter of fitting grease nipples, which enable grease to be pumped in with a grease gun. Unless this can be done, it is extremely difficult to get the grease into a bearing, and no amount of grease slapped on the outside of a bearing does any good at all. Probably the best method may be said to be: "take it apart, grease it, and put it together again."

There is a good deal to be said for the use of heavy oil, about SAE 140, for control systems, particularly for control surface hinges. Where the latter are of the usual pin-and-split pin type, the only satisfactory way to get grease into them is by taking them apart. Slapping grease on the outside only seems to result in a frightful-looking sort of toffee-apple of dust, sand and mud forming around the hinge. To strip every hinge is a long job. Now, heavy oil does creep into the bearing surfaces, and it does not take long to go round a glider and put a drop on each hinge.

The points which do require regular attention are as follows:—

1. The release hooks.
2. All control surface hinges.

3. All pulley bearings (*bearings only please*).
4. Stick bearings and torque tube bearings.
5. All control lever bearings and the pins which connect the levers to the rods or cables.
6. Landing wheels unless of the sealed ball-bearing type.

You cannot do any harm by over-lubricating provided (and this is important) the oil or grease goes where it is meant to go. You can do a good deal of harm by allowing oil or grease to get into places where it should not be. Therefore take great care that no lubricants get into the wrong places. These are as follows:—

1. On to any timber. If left, the timber will soak up the oil and eventually become rotten.
2. On to any fabric. The same will happen.
3. On to any cables. The result of this is that the oil, or grease, will collect grit and form a grinding compound which will wear away the cable where it passes over pulleys, or through fair leads.
4. On to any rubber. If left, the rubber will dissolve into a horrid sticky mess.

If you should accidentally spill a little oil in any of these places, wipe it up at once; it will save you a lot of work in the end.

Finally, how often should you lubricate your glider? This is a difficult question, as so much depends on the conditions under which the glider operates and is stored. You will be fairly safe, however, if you make a rule to do it about every 20 hours' flying, or once a month at least.

Corrosion

This is the chief enemy of the STEEL in your glider. There are several ways of combating it, but all of them depend on covering the metal with a protective skin. Some steel parts are cadmium or chromium plated, but the most usual method is by the use of some sort of paint. The principle to follow is this: keep the protective skin intact. If you see any rust developing, remove it carefully with a wire brush or fine emery cloth and repaint. If you have to do

this, please make sure that the corrosion has not weakened the fitting appreciably. If it has done so, you *must replace it* with a new fitting. There are a few metal parts which cannot be painted, such as spar pins, etc. These must be kept covered with grease.

There is one other place where corrosion must be guarded against, and that is wherever wood and steel touch. Wherever there is plate fitted onto a wooden member or wherever steel bolts pass through timbers, there is a chance of corrosion due to the moisture in the timber itself. If you have to replace bolts or plates in these conditions, make sure that both wood and steel have a liberal coating of chromate jointing compound before assembly.

Timber and Plywood

Both these will deteriorate if they are allowed to become too wet or too dry. The timber and ply was in its best condition when your machine was built, and your aim should be to keep it so. Therefore ensure that the protective covering on all the woodwork is kept intact and touch up with the paint brush whenever necessary. This is particularly important if your machine is built with casein glue as damp will cause a fungus to form and attack the glue.

Fabric

When the fabric was applied to your machine it was doped to tighten it, and to make it waterproof. The doping scheme ought to have included in it at least one coat of aluminium dope to make it opaque as well, although there are still some machines flying with clear-doped fabric. The main enemies of fabric are ultra-violet light, which rots the fibres, and oil, water or acid which will eventually destroy it. Therefore, keep these things away from fabric as far as you can. If the doping was properly done, the fabric should be impervious to water so the odd shower of rain will do no harm. However, if water gets inside the wing, it may be able to soak the fibres of the fabric, so keep the drainage eyelets clear. Ultra-violet light is a thing you cannot do much about, except to avoid sunlight for unnecessarily long periods; and in any case, if the doping is really opaque, the ultra violet light will be prevented from getting at the fabric. In brief, keep the fabric clean, and do not let the sun get at it more than necessary.

Instruments

Modern aircraft instruments are extremely reliable bits of mechanism, and if anything does go wrong with them, it is generally much better to send them either to the manufacturers, or to a specialist firm for overhaul. The difficulty is that even if one knows what is wrong with them, they must be checked for accuracy after any adjustment, and this almost always requires a special calibrating gadget of some sort. However, to prevent trouble developing, the following points should be borne in mind:—

1. Use good quality rubber pipe for the connections, and replace it whenever there are any signs of perishing.
2. Keep moisture and dust out of instruments and their piping.
3. Do not subject instruments to rough treatment, shocks, etc., and do not blow into Air Speed Indicators or Variometers.

Cables

Most gliders use cables in their control circuits, and it is most important to keep the cable tensions correct. If the tension is too slack there is a risk of turnbuckles fouling ribs or bulkheads, while if the cable is too tight the fittings may be subjected to unnecessarily large loads. The effect of "g" on cable loads must not be overlooked. In a loop, for example, the elevator cable of most gliders is subjected to quite a big increase in tension, since it is only supported at two points about 15 feet apart. Due to the extra "g," it tries to sag, and if the tension was tight to start with, the increase of tension may be very great.

Cables tend to stretch and shrink as the temperature increases or decreases, so they may require adjusting fairly frequently. While on this point, remember that a sail-plane sitting on the ground in a temperature of 75°F. or more, on a fine sunny summer's day, may well be at 8,000 ft. a short time later, where the temperature will probably be around freezing point; so do not over-tighten the cables in summer.

What is the correct tension for cables? This is a very difficult matter to describe in print, and is much better learnt by an actual demonstration on a glider. However, here are two rough guides. On a machine such as a Tutor with no mass balance on the elevator, the tension in the elevator cable is about right if the stick will just fall forward due to the weight of the elevators. On a

machine like the Olympia, the cable is about right for tension if you just cannot feel a "tight-spot" in the elevator movement. This latter case is of course complicated by the fact that the elevator is partially mass-balanced, so the first method does not work properly. Use these tensions as a guide to the setting of aileron cables. Rudder cables on most gliders are bungee-tensioned in the nose of the machine, and in this case they look after themselves as regards tension. We are assuming, of course, in all these tests, that the control circuit is properly lubricated.

Safety and Locking

All parts of a glider must be so fitted and locked that there is no risk of anything working loose or coming undone. We can consider turnbuckles first. One commonly used type has a barrel in which there is a socket at each end with right and left handed threads. Into these sockets screw the eyebolts. With this type, all the threads of the eyebolts must be inside the barrel if the turnbuckle is "in safety" or able to develop its full strength. If any threads show, then the cable must be increased in length, by the addition of links, etc., to allow full engagement of all the threads. A second type of turnbuckle, found on

Olympias and other gliders, consists of a right and left handed screw for the central portion, and this fits into two sockets which are swaged onto the ends of the cable. In this type the central screw is threaded almost up to the middle, and there is a different method of determining whether sufficient threads are engaged with the sockets to provide full strength. On each socket will be found a small hole, about $\frac{3}{8}$ inch from the mouth of the socket, and this is the "safety hole." The socket is "in safety" if the screw has been screwed in past this hole. This must be verified, either by looking into the hole or by feeling with a pin or piece of wire. This type of turnbuckle also has two brass locknuts which should be screwed back against the sockets when the adjustment is correct. In spite of these locknuts, the turnbuckle *must* be properly wire-locked as described below.

All turnbuckles must be locked against possible movement. Soft iron locking wire is generally used for this, and it can be bought, galvanised, very cheaply at any ironmongers. There are two accepted methods of locking turnbuckles. The first, shown in Fig. 1 (a), is done by passing a length of wire through the hole in the middle of the barrel, bending the ends up and passing them through the eyebolts or

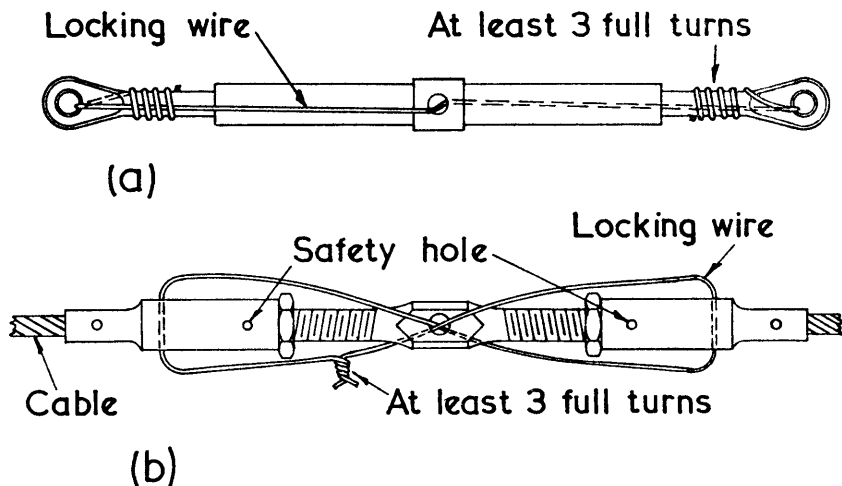

Fig. 1

fittings. The ends are then wrapped round the shanks of the eyebolts (and the wire itself) for at least three full turns, but preferably more.

The second method, sometimes called the "figure-of-eight" lock, is preferable where the turnbuckle is in an inaccessible place, and the wrapping round of the ends is a difficult job. In the screw type of turnbuckle, each socket will be found to contain some more holes. One, near the cable end, is a little blind hole and was used by the makers to ensure that the cable was fully home before it was swaged in. This hole does not concern us, but near it is a hole right through the socket. This is the locking hole. The wire passes through this hole, crosses through the hole in the central screw, through the locking hole in the other socket, and the two ends are twisted together with at least 3 full turns (preferably more) to form a complete figure-of-eight as shown in Fig. 1 (b). This may seem more complicated than the first method, but you will find that it is not. One can usually fiddle the wire in easily enough, but often the wrapping down of the ends is very difficult in a confined space, using the method of Fig. 1 (a). The advantage of the second method is that

once the wire is threaded into place, and the ends brought together, a pair of pliers can be used to twist up. Whatever type of locking is used, always fold down ends of wire so that no fouling can occur.

Bolts are used all over the structure of most gliders, and all bolts must be locked so that there is no danger of the nut accidentally working loose. One simple way of locking a bolt is to bash the end over until it is riveted over the nut. This is an admirable method for bolts which, you hope, are never going to be undone. The snag is that if ever you do have to take the bolt out, it, and its nut, must be scrapped and a new bolt and nut fitted. The next method is by means of a castellated nut and split pin fitted through a hole in the bolt. This is very satisfactory, but in awkward places attempts to get the split pin into place can lead to much bad language. There are on the market a number of so-called locking washers which do the job quite well. They have a serious disadvantage, however, in that all of them tend to cut the fitting and the nut with their locking elements, teeth, claws or whatever you like to call them. You will do well to avoid them on gliders.

Lastly we come to the Stiff nuts, Nyloc,

WRONG

CORRECT

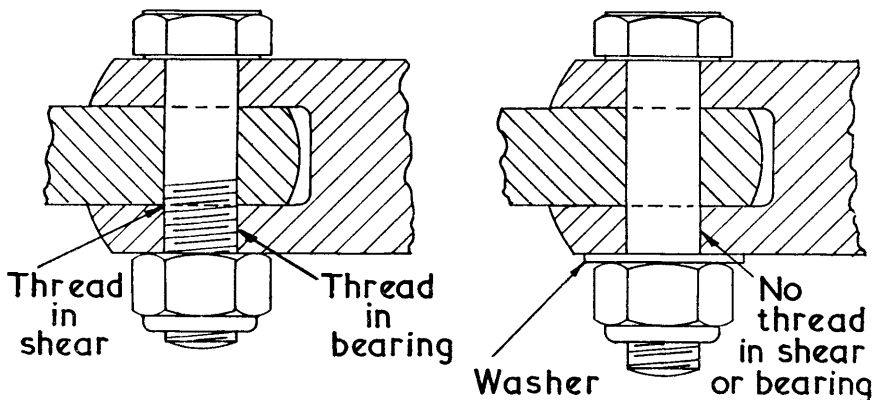

Fig. 2

Simmonds nuts or Pinnacle nuts. These are self-locking nuts and they really are self-locking. They have none of the snags of the above methods and should be used whenever possible. One small point: make sure that the bolt thread does go right through the nut, otherwise the self-locking element may not be able to do its job. These nuts may be used over and over again, but reject any which do not seem to be reasonably tight on the thread. As a rough guide, if you can screw the nut right on with your fingers it should be scrapped. Some manufacturers prefer to use slotted nuts and split pins in control circuits, etc., where there is a chance of the bolt rotating, and you should always use the same method as the manufacturer.

One method of locking which is sometimes seen should *not* be used on gliders. This is the practice of screwing down a second nut tight onto the first one. It is an unreliable method and usually damages the bolt threads.

When replacing bolts with new ones, make sure that the new bolt is the correct length. Bolts should not be fitted with their

threads in shear or in bearing. Fig. 2 should make this clear.

For this reason a washer should always be fitted, and you should check that the straight portion of the bolt does actually reach right through the fitting but not through the washer.

Wing pins should be good fits in their holes and should be kept greased. The usual way of locking these is to fit safety pins, though if a machine is only very rarely derigged, it is a good plan to use split pins and washers. These do not rattle so much, and are not so liable to catch on clothing, etc. This can be a danger with safety pins in exposed places, and it is quite easy to pull open a safety pin unnoticed from this cause.

Finally, a few general points. Never use a split pin more than once. Always use the correct size of split pin or safety pin. Always use non-corrodible split pins. Do replace locking wire with new if you have to unlock a turnbuckle. Do watch for corrosion, bad fabric, slack fittings, hinges, faults in wood-work finish, etc., and deal with these matters at once.

OTTLEY MOTORS LTD.

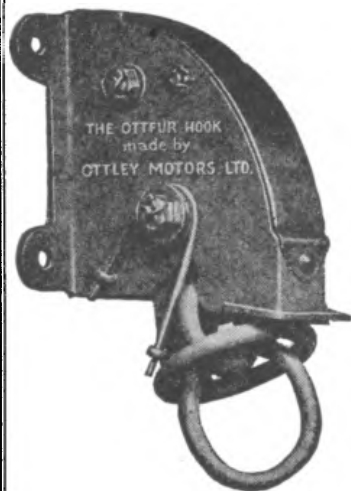

Established over 30 years as repairers of all types of mechanical devices, including engine overhauling and tuning.

Manufacturers and repairers of all types of motor bodies, chassis, etc. Finishes on metal and wood of all descriptions including cellulose and varnish.

*Designers and Manufacturers of the
Ottfur Release Gears. Suitable for
Sailplanes and Aero Tugs.*

Manufacturers and repairers of all types of Sailplanes and Gliders. Machines collected and delivered.

A.R.B. Approved.

Fully experienced staff for all departments.

Estimates free.

**11 CRESCENT ROAD, WOOD GREEN,
LONDON, N.22**

Telephone: BOWES PARK 4568

2. REPAIRS. GENERAL CONSIDERATIONS

REPAIRS are usually the result of accidental damage to a glider. They may be necessary, however, as a result of bad maintenance, or plain old age. If you carry out the necessary maintenance on your glider conscientiously, you should be able to eliminate almost entirely repairs due to bad maintenance, but it is obvious that no part of a glider can be considered to last for ever, and will, sooner or later, require replacing or repairing.

The first thing to remember about any sort of repair is that you *must* only use approved materials in your repair. When the machine was designed and built, great care was taken to ensure that every part of the glider was strong enough for its job. Quite as much care was taken to see that no part was unnecessarily strong, for in this case the glider would be heavier than it need be. Now, in calculating the strength of all the pieces of the glider, the designer used as a basis the known strength of approved aircraft timber, spruce, ply, etc. and the known strength of various specification steels. If you, subsequently, go and replace some of these high-quality materials with any old bits of wood, or metal, your repair may look all right but it will most certainly be all wrong.

An Inspector of Aircraft Materials is a highly skilled man, who has at his disposal a fair amount of testing equipment, and nobody suggests that we should all become Inspectors and set up our own test laboratories. But you must—and this cannot be stressed too highly—you really must make sure that nothing goes into your glider which has not been tested and approved. The best way of doing this is to buy your supplies from reputable firms and to insist upon an Approved Certificate or Release Note for whatever you buy. All good firms issue these Notes as a matter of course and usually the material, wood, ply or metal, bears a stamp or mark which is quoted on the Release Note. All repairs must, of course, be entered up and signed for in the glider's log book, and against the entry for the repair you should enter the number and date of the Release Note for the materials used in the repair. It is, if you like, your proof that you did use proper aircraft materials for the job. The name "Release

Note" puzzles some people. It is merely a note issued by an Inspector that he has examined the material in question, that he is satisfied that it is up to standard and that it may be "released" from store for use on aircraft.

A good repair on any aircraft must satisfy four requirements:—

1. It must be at least as strong as the original structure.
2. It must be as nearly as possible as rigid, or stiff, as the original structure but neither more nor less so.
3. It must not be appreciably heavier than the original structure.
4. All protective coverings, paint, dope, etc., must have been made good.

If, when you have completed a repair, you can honestly say that it fulfils all four of these requirements, then you have every right to call it a good repair.

Let us take these four requirements in order.

No. 1, strength, is obviously vital, for on it may depend your life. First, there must be no doubt as to the material in the repair. This is satisfied so long as only Approved materials are used. Secondly, the repair scheme must be worked out and splices, etc., made correctly. For many jobs, standard repair schemes can be employed which have been found satisfactory by many tests. If no standard repair scheme can be used for a particular repair, then one must be worked out. This means that you must plan what damaged material has got to be cut out, how you are going to replace it, where the joints are going to be, and whether any temporary structure has got to be fitted to hold the component secure while the repair is made and glue is setting. This matter is dealt with more fully in a later chapter. If the repair is a replacement of a component, then this aspect of the job is simple.

Your workmanship must be of aircraft standard. Now, this does not imply fantastic skill. Any normal person can fairly quickly acquire sufficient skill with wood-working tools, and files, and hacksaws, to produce first-class repairs. The operations in themselves are relatively simple, but you

must make sure that nothing but first-class work goes into your repair. All wood joints, splices, etc., must fit. If they do not, then they must be chiselled, filed, sandpapered, until they really do fit. Unless the repair is a relatively small one, in which case you can use the damaged parts as patterns, you will need to obtain drawings of the damaged component, and you must make sure that the sizes of timber and thicknesses of ply, dimensions of gussets and all other details are exactly as called for in the drawing.

One might be forgiven for thinking that, if a repair is strong enough, then it is satisfactory. Things are not quite as simple as this, however, and this is where this business of stiffness comes in (our No. 2 Requirement). Take, for example, the spar of a cantilever wing. The booms, or flanges, of the spar are carefully tapered, being thick at the wing root where the big bending loads act, and thinning out at the tip where the loads are lighter. Built like this, the whole spar will bend evenly and smoothly like a well-designed bow. Now, suppose we make a repair to the spar somewhere near the middle of the wing, and, misguidedly, we beef it up with lots of timber and make it very stiff at this point. The spar will now not be able to bend, or flex, at the repair point, and in consequence it will throw a lot of extra load onto the sections of spar at the ends of our repair. If it fails, it will

not fail at our repair. Oh no! Our repair is much too strong, but it will fail at the ends of the repair. Do not get the idea that we have somehow weakened the spar at these points. The spar here is as good as ever. What we have done, though, is to put a lot of extra *load* onto these points in the spar—extra load which they were not designed to cope with and which ought to have been spread over the repaired portion evenly. The net result is that the spar as a whole is weaker than it should be.

Requirement No. 3, that the repaired job should not be appreciably heavier than the original, will, in general, be satisfied if the repair satisfies our first two requirements as to strength and stiffness. A repair is almost bound to involve some extra weight, but this should be kept as small as possible. In all big repairs, and any repairs which are a long way from the centre of gravity of the glider, the machine must be re-weighed, and its new centre of gravity determined. Any alteration in weight or C. of G. position will alter the permitted maximum and minimum pilot weights.

Requirement No. 4 should be only common sense. Apart from appearances, it is clearly lunacy to spend time and money on a good repair job without making sure that, when the job is finished, the elements cannot get at your work and destroy it.

Sailplane and Gliding

The sports only magazine

PUBLISHED EVERY OTHER MONTH

60 pages of illustrations and articles for the gliding enthusiast all over the world.

17s. Annually (U.S.A. \$3.00) or Single Copies 2s. 10d.

from:

**BRITISH GLIDING ASSOCIATION
LONDONDERRY HOUSE,
19 PARK LANE, LONDON, W.1**

3. TIMBER AND PLY REPAIRS, GLUES

ALL the wooden parts of a glider are held together by some sort of glue, so we might well begin this chapter with a dissertation on glues and their properties. First, let us realise that a properly made glued joint is actually stronger than the wood that it is holding together. This is true of all Approved glues and, of course, you must use no other. This means that if you make a test joint, and then tear it apart after the glue has set, the joint will not break in the glue line but will tear away the wood fibres from one side of the joint.

Now, to get this strength from a glue joint the glue has got to be used properly. Glue must always be used in shear, and never in tension. Fig. 3 should make this clear.

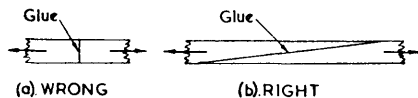

Fig. 3

In Fig. 3(a) the glue line is in tension, i.e. is tending to be torn apart, and a joint made like this is hopelessly weak. In Fig. 3(b) the jointed pieces of wood are not so much being torn apart, but more trying to slide one over the other. The glue line is in shear and its strength is enormous. Also please note that in the latter method we can make the area of the glue surface as big as we like by making the slope shallower and therefore longer.

Glue must always get right down at the wood, so the joints must really fit properly before gluing up. Equally important, the wood surfaces must be clean, and this does not simply mean scraping off any paint. It means that, after sanding the surfaces, you must not touch them even with clean hands. The perspiration from even clean fingers will be left on the joint and the oiliness will interfere with the proper penetration of the glue. Lastly, the joint must be so held or clamped so that no movement is possible until the glue has set.

Aircraft glues, in the U.K. at any rate, are of two main types: Casein Glues and Synthetic Resin Glues.

Casein Glue is a white powder and is made from milk by a chemical process.

Mixing instructions are always included with the powder and should always be followed exactly, since the different makes of glue have slightly different mixing techniques. A typical mixing method is: mix the powder and cold water to a thick creamy consistency, allow to stand for 20 mins. and the glue is ready for use. Three hours (or sometimes four, depending on the make of glue) after mixing, the batch must be thrown away and a new batch mixed. Casein glue does not simply dry out like a gum, but it sets by chemical reaction. It is an excellent glue if properly used. It is not "gap filling", and in consequence the workmanship and cleanliness of surfaces must be of the highest order. In use, it is spread evenly over both surfaces of the joint, which are then clamped together with as much pressure as possible, short of damaging the timber fibres. Setting time varies with different makes and the ambient temperature, but is of the order of 24 hours.

Casein glue is waterproof, but it has one serious disadvantage. If it gets wet, it is liable, being an organic substance, to fungus attack; and once this starts, the glue joint is rapidly destroyed. To guard against this, casein glued aircraft are usually sprayed internally with a light coat of shellac.

Casein glue is not much used these days, but there are quite a number of older gliders still flying which are casein-glued throughout. In case of repair, it is better to use the same type of glue as was used in the original structure, so these machines should be repaired with casein glue.

The most widely used Synthetic Resin Glue, in the U.K. at any rate, is Aerolite. This is really a plastic which has been arrested in its hardening and so remains liquid. The hardening process can be started by bringing the glue into contact with a catalyst or Hardener. In consequence, this is what is called a Double Application Glue. In use, the glue, a whitish treacly liquid known as Aerolite 300, is spread evenly on one piece of wood, and the Hardener, a liquid usually stained with a dye to assist identification, is spread over the other piece, the surfaces having been carefully prepared. When all is ready, the two pieces of wood are brought together and clamped in position while the hardener-treated surface is *still damp*. This last point

is most important. The clamping pressure need not be anything like so great with this glue; in fact, the best joint is ensured when the pressure is only just sufficient to guarantee that the surfaces are in proper contact all over the joint. This glue is said to be gap-filling, but this must not be made an excuse for inferior workmanship.

Setting begins immediately the glue touches the hardener, so the two must never come into contact except as above described. Setting times vary enormously with temperature, and, if suitable heat can be applied, may be reduced to an hour or so. Times also vary depending on which speed of hardener is used. This is made in three speeds, "Rapid" (coloured amber), "Medium" (coloured green), and "Slow" (coloured violet). The last two will be found the most useful for glider repairs, and it is a good rule to use the slower hardener if you have a choice, since this allows more time for tacking or clamping up. The available times for this are quoted on the manufacturer's instructions sheet. These hardeners can be obtained undyed, or colourless, but their use is not recommended. The purpose of the dye is to prove, conclusively, that the hardener has been used. The makers of this glue, Messrs. Aero Research, Ltd., of Duxford, Cambridgeshire, supply, with every batch, full instructions for use, and temperature/setting time tables for the various speeds of hardeners. When using this glue, some form of artificial heating must be used if the temperature is below 40°F. This can usually be quite easily arranged, a favourite method being to fix ordinary electric light bulbs with some form of reflector around the joint. It is quite surprising what a lot of heat can be applied in this way. Hot water bottles will also be found useful on occasions.

Being a plastic, the glued joint is unaffected by moisture, fungus attack, or anything else. However, in its liquid form, Aerolite 300 does tend to harden very slowly and for this reason the store life of the glue is three months from date of manufacture. After this period the glue must be thrown away, or, at any rate, not used for aircraft work, though it may be quite good enough for trailer repair and suchlike. The hardeners have an indefinite store life.

The makers also produce the same glue in powder form. This is known as Aerolite 306, and when mixed with water, in the

correct proportions, forms Aerolite 300. The advantage of this is that, in powder, the glue has a store life of two years, so that batches of glue can be mixed up as required. This is a very convenient way of using Aerolite, but make sure that the mixing is done in the correct proportions and that all air bubbles are removed from the glue before use. This may take one or two days. Keep in an airtight jar, or a skin will form on the surface. This skin will not re-dissolve and must be removed.

Finally, do keep the glue and hardener apart at all times. If one drop of hardener accidentally spills into the glue pot, that glue is infected and must be thrown away.

Aero Research, Ltd., also make another glue known as Aerodux. This is not often come across, but it is an excellent glue. It is a Synthetic Resin, but has one snag from our point of view. It is very slow setting—in fact, its full strength is not developed until about seven days after the joint is made. This does not matter much from the constructional point of view, but it is a serious drawback when considering repairs. This glue is a red treacly liquid and the hardener is a white powder. When required for use, the correct amount of the hardener powder is stirred into the glue. The glue is then ready for use and remains usable for a few hours depending on the temperature. This glue is applied to both surfaces to be joined, and the joint is clamped up in the usual way. This glue has much to recommend it when building a large component or repairing a spar, since the time element is much less critical. Initial setting is fairly quick—a matter of a few hours, but final hardening to produce full strength as stated above is rather a lengthy business. This glue is used fairly widely in the manufacture of rotor blades for helicopters, and other high-duty applications.

Timber Repairs

It will help you enormously if you can obtain a copy of A.P. 2662A entitled "Standard Repairs to Airframes". Although it bears on its cover the statement "Promulgated for the information of all concerned", someone has decreed that this is a "Restricted" publication and cannot be bought by the public. It may be difficult for ordinary intelligence to see quite how the Queen's enemies might benefit by the

possession of this book; but, as we all know by now, "the man in Whitehall knows best". However, the British Gliding Association will probably be able to obtain a copy for you, provided you can satisfy them that you are not a lunatic, or an anarchist.

There are, in this book, many worked-out schemes for the repair of almost every type of damage, and if you follow the scheme appropriate to the job you are repairing, you can hardly go wrong.

However, if you cannot obtain a copy of A.P. 2662A, we had better consider timber repairs from first principles. Timber is joined to timber by glue and nothing else. Any odd tacks, or screws, you may find are virtually unstressed, and were fitted to ensure that the gluing up of the original joint was satisfactory. This, of course, does not apply where you find a metal component screwed to a wooded one, e.g., a skid shoe on a main skid. Therefore, when we have to make good any damage to a wooden structure, we must do it by means of wood and glue alone.

Most gliders are built of spruce for the main load-carrying members, with birch or gagoon plywood for skinning and bracing bulkheads, or forming spar webs, etc. Let us consider repairs to spruce members first.

Basically there are two main types of glued joint; the lapped joint and the scarfed joint. The lapped joint is normally only used for trivial repairs or repairs to comparatively lightly loaded members.

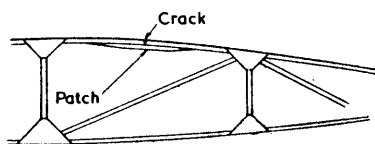

Fig. 4

Fig. 4 shows a patch repair using a lapped joint to repair the top boom of a wing rib. In this case the patch piece must be of the same dimensions as the original boom, the ends must be chamfered down to a slope of at least 5 to 1 and the parallel portion of the patch piece must be at least ten times the thickness of the original boom. The patch piece is simply glued into position and cramped or clipped until the glue has set. For this purpose, bulldog clips, or spring-type clothes pegs, will be found very useful.

This is a very simple and quick repair but its disadvantages are obvious. We have made the job heavier, and we have increased the stiffness of the boom. These disadvantages are not very important in a small repair of this nature, and the boom is a comparatively lightly stressed member, so we can call this a satisfactory repair. Note that the ends of the patch piece must be chamfered to avoid the sudden change of stiffness there would otherwise be.

Except on trivial repairs and lightly stressed members, this system is not good enough, and we must look for a better way.

This better way is the scarfed joint, and is illustrated in Fig. 5.

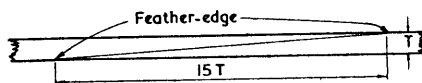

Fig. 5

To make the scarfed joint the two ends of the pieces of wood are planed, shaved, and filed down until they fit as shown in the figure, and then glued. The length of the scarf must be at least 12 times the thickness of the wood, but should be 15 times if it is possible to make it so. Never forget that a long splice is much easier to make than a short one, and the glued area is correspondingly greater so that a better joint results. A 12 to 1 scarf, or splice is satisfactory, but the individual scarfs must fit absolutely perfectly. It is a very good rule to make all scarfed joints in solid members to slope at 15 to 1 for this reason, and only use the 12 to 1 slope if it is absolutely impossible to use the full length of 15 to 1.

One further point needs a little consideration. This is the feather edge, or point of each scarfed piece. It is clearly vulnerable either during the gluing, or later in service. If the member is subjected to any bending in the plane of the glue surface, then any tendency for the feather edges to lift will cause a crack to try to creep in and force the scarfed surfaces apart. To prevent this, it is a good plan to glue, over the feather edge points, a reinforcing strip. Now, A.P. 2662A shows reinforcing strips made from spruce. In general on gliders our repairs will be made on much thinner sections than is usual on Service aircraft, and ply reinforcing strips are quite satisfactory. The strip should be at least 6 T long on the

parallel portion (T being the thickness of the repaired member) and the ends must be chamfered down to a slope of at least 5 to 1 as shown in Fig. 6.

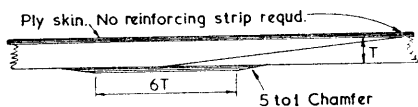

Fig. 6

If one side of the scarf is glued against a ply skin, as shown on the upper side of the scarf in Fig. 6, then of course no reinforcing strip is needed, since the skin performs this job. The grain of the strip must run, on the outer veneers, parallel to the grain in the scarfed member. As regards thickness of strip, $\frac{1}{16}$ in. ply will serve for members $\frac{3}{8}$ in. square to about $\frac{5}{8}$ in. square, and proportionately, though above $\frac{3}{4}$ in. square sections it is probably better and easier to use spruce reinforcing strips of a thickness of $\frac{1}{4}$ T where T is the thickness of the member.

Do not let the fitting of a reinforcing strip be an excuse for inferior workmanship. Its purpose is solely to prevent the possibility of the points of the scarf from working open. The strength of the joint must be in the scarfed joint itself.

Plywood Repairs

Here again we have two basic types of glued joint, the lapped joint and the scarfed joint. The lapped joint is mainly used in patching minor damage. Patches of ply should be of the same thickness and grain direction as the original ply and should be glued onto the back, or inside, of the panel. All edges should be chamfered down at a slope of 5 to 1. Patching is useful for repairing odd cracks, holes, etc., in lightly stressed panels of ply, provided these are small and of minor importance. Do not use this method for important ply panels such as leading-edge ply, etc. For this type of repair, as, in fact, for the majority of ply repairs, scarf joints must be used.

You know, by now, that you must only use Approved plywood, but here is a word of warning. You will come across two different types of plywood in glider construction. The first, or ordinary plywood, consists of three veneers of wood, the outer

two veneers being laid so that the grain runs parallel with the length of the sheet, while the centre veneer is laid so that its grain runs at right angles to the two outer veneers—i.e., runs across the sheet. This is the most common type of plywood. The second type, sometimes called Shear Ply, Diagonal Ply, or 45° Ply, is a high-duty plywood used in positions of great stress such as spar webs and, sometimes, leading-edge ply. In this ply the outer veneers are each laid at 45° to the long edge of the sheet. This ply has enormous strength in shear, and must never be replaced by ordinary ply.

Grain is very important in ply panels, and all replacements, insertions and patches must be arranged so that the grains run as in the original structure.

Making scarfed joints in plywood is basically the same procedure as in solid timber, with a few exceptions. The length of the scarf must be nine times the ply thickness—no more and no less. If you try to make the scarf longer, you will almost certainly lose strength through the feather edges breaking. A shorter scarf is not up to strength. No reinforcing strips are required, but, of course, any fabric used as a protective covering must be made good. The scarf must be very accurately made, the surfaces must be really flat and must fit perfectly before gluing up. This is made easier by the laminated form of plywood, since a good scarf shows three straight stripes, of equal width, where the three veneers have been shaved down. Mark off your scarfs with a pencil line before you start and shave down with a file rather than a plane. The latter is rather too greedy and tends to break up the feather edge. The new "carrot grater" type files with replaceable blades will be found very useful for scarfing ply.

All ply scarfs must be backed; i.e., there must be a rib or frame behind the scarf, or it is impossible to close the scarf for gluing. Moreover, the backing must be at least three-quarters of the width of the scarf, and, if necessary, the rib, or frame, must have a strip of timber glued alongside it to make it up to this thickness. If there is no rib or frame to use, then you must fit a backing piece, glued into place. Never try to scarf onto thin air, i.e., without backing; it is a waste of time.

If you consider that a backing piece is materially increasing the stiffness of the structure at the repair, it may be advisable to remove it again after the repair is finished.

The usual method of closing up a scarf joint in ply is by means of a tacking strip. This is a strip of plywood about an inch wide which is tacked down over the scarf. The operation is made much easier if prepared strips, with the tack already stuck in them, are made up beforehand. When the joints have set, these strips are removed and the tacks drawn out again. As a general principle, all tacks should be removed after a repair. If you find, as you may, that on a particular job some tacks cannot be removed owing to inaccessibility, then these tacks must be of brass. Otherwise steel tacks may be used, but these must be

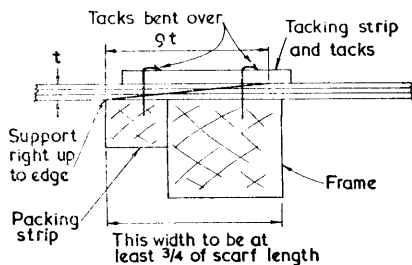

Fig. 7

removed or corrosion will set in and damage the timber. Fig. 7 shows a typical ply scarf repair.

There is another type of repair which falls rather between the two types described above. This is the Flush Insertion type of ply repair. It is useful where damage is too big for a small patch but not sufficient to justify scarfing in a new panel. It is made by cutting out the damage to an oval shape or rectangle with radiused corners and gluing in a "biscuit" of ply inside the panel. Do not make the hole circular unless you can get at both sides of the panel, otherwise you will not be able to get the biscuit through the hole. When the biscuit has been glued in, a patch can be cut to fit the hole exactly and glued into place. All outer edges of the biscuit should be chamfered to a 5 to 1 slope, and all laps should be at least 1 inch. Fig. 8 shows a sketch of this type of repair. It is not used much on gliders since the panels in general are fairly small, and usually it is easier to scarf in a new piece onto the nearest frames or ribs.

When replacing a damaged panel of ply with a new one, if you have to make a scarf

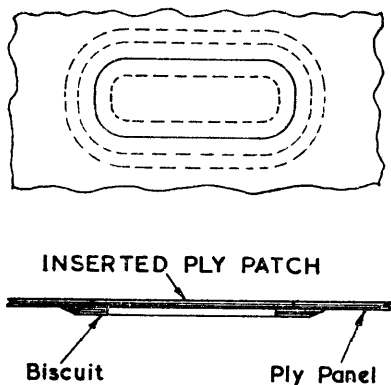

Fig. 8

joint at a place where there was originally a scarf joint, do not worry about the direction of the original scarf. If the new joint is in the same direction as the old one, then things are easy. Simply shave down to the old scarf joint, clean off all old glue until you have a good timber surface, and glue in your prepared scarfed panel in the ordinary way. However, if the old scarf ran in the opposite direction, then ignore it. Scarf in the new panel as usual. The joint will be amply strong. Fig. 9 shows a cross section of a new scarf running in the opposite direction to an old one.

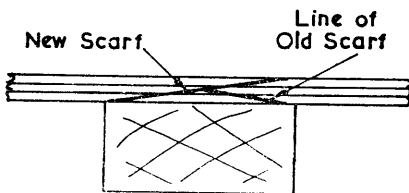

Fig. 9

This procedure of a new scarf crossing an old one should be avoided in solid spruce members. The question does not really arise since normally we can put our splices in these members more or less anywhere we like, whereas in ply panels we have to make them where there is sufficient backing, i.e., on frames or ribs.

Whenever gluing ply, it is important that the surfaces are properly sanded before gluing, since the process of manufacture tends to close up the pores.

4. METAL REPAIRS

THE metal parts of most gliders are, in general, much better replaced, if worn or damaged, rather than repaired. There are a few exceptions to this rule but not many. For instance, skid shoes wear out fairly rapidly if gliders are operated on hard surfaces, and it is quite a simple matter to cut off the worn part of a mild steel main skid shoe and weld on a new piece of sheet steel. Tailskid shoes also can be repaired in this way, though in this case a thin plate of cast iron welded on to the sole of the tailskid shoe, and then quenched to leave it glass hard, seems to stand up to hard work better than anything. However, apart from trivial things like these, no welding must be done on any aircraft structure except by an A.R.B. approved welder. This is an absolute hard-and-fast rule, and you break it literally at your peril.

If metal parts of a glider become distorted or worn, replace them. The only real excuse for repairing or reconditioning them is when the parts are difficult to obtain, as may be the case when the glider is a "one off" job.

One instance of this is when the wing/fuselage pins become worn. The easiest method of dealing with this is to replace the wing and fuselage fittings and to fit new pins. If you cannot get them you must think again. You may be able to ream the holes oversize and fit oversize pins, but you must not do this until you have received the manufacturer's approval. The new pins will have to be made, not only of Approved steel, but of the actual specification called for on the drawings. The snag with this system is that the components are then non-standard, and, while this does not matter on a "one off" glider, it's a darned nuisance on a popular type of machine, since its parts will not fit any other machine of the same type and *vice versa*.

Metal fittings must be inspected frequently for any signs of corrosion or damage. It is often not realised that even a light scratch can be the starting point of a fatigue crack; so keep fittings clean and painted, and do not scribe things on them. In this connection the writer has seen a Sky sailplane whose owner, misguidedly, had scored a line across the top spar joint fittings to assist him in rigging. Why he could not have painted a line on these fittings was not explained. The

latter plan would have been quite useful, but the scored line across this heavily stressed fitting is simply asking for fatigue trouble.

Fatigue in metal is a most deadly thing. Fortunately in our gliders we find very little High Tensile Steel used. Nearly all fittings, bolts, etc., are made of Mild Steel (although it is an aircraft specification mild steel), and its behaviour under repeated loading, such as would produce fatigue failure, is perfectly predictable, unlike some light alloys. This means that there is no danger whatever from fatigue so long as the fittings are in good condition. If, however, the fittings are allowed to become corroded or scratched, there will be concentrations of stress at the weakened points, and this will cause cracks to grow from them. For the same reason, if a fitting is overstrained it must be replaced.

Release hooks, in this country at any rate, are almost all of the Ottfur type. This type is a safety hook, in that it will throw out the cable ring if the cable pull exceeds a certain angle, as will happen if a pilot forgets to pull the release at the top of a winch launch. It is most strongly recommended that no other type of quick-release hook be used, and also that only approved winch rings be used on launching cables. The practice of making up rings locally from any old mild steel bar is a very dangerous one; the rings may distort under load, and it is possible for a distorted ring to jam in the release. An approved winch ring cannot possibly jam, and it is not an expensive item. Nose hooks, intended for aero-towing, on some gliders, are locked by a pin or bolt. This prevents the release hook from "back releasing" and is intended to safe-guard against an accidental release occurring when the tow cable surges and develops an undue amount of slack. This might be awkward if you were over the middle of the Channel at the time! These nose hooks must not be used for winch or auto-tow launching unless the locking pin, or bolt, is first removed.

These Ottfur release hooks are made in several forms, differing mainly in the position, and direction of pull, of the opening lever. Apart from replacing broken springs, etc., it is a waste of time and effort trying to repair or recondition them. Messrs. Otley Motors Ltd., the manufacturers, run

a service for rebuilding these hooks, and the charge is so small and the service so quick that it is far and away the simplest and cheapest way of overhauling them. Your hook comes back to you as new, repainted and proof tested, and with a Release note certifying it O.K.

These release hooks work on what is known as the "Over Centre Mechanism" or "Toggle Joint". This is much better understood with the aid of a diagram. Fig. 10 shows the basic works of a release hook. The "back-releasing" action is not shown since that is obvious immediately on examination of an actual hook.

In the figure the release is shown locked (upper drawing) and open (below). In the upper sketch it will be obvious that no pull, however heavy, on the jaw of the hook can open it, since the pivots of the links are slightly over the straight-line position AB (hence the name "Over Centre Mechanism"). The links are merely forced against the stop. At the same time quite a small force P, applied at the opening lever, is enough to lift the links off the stop, and once they pass the straight-line position the release will fly open into the position shown in the lower drawing. A little thought will show that the position in which the links come to rest in the locked position is rather critical. A small alteration here has a very large effect on the pull necessary to operate the release when under load. Wear in the pivots affects the locked position and should be guarded against by proper cleaning and lubrication of the innards of the release. A worn release usually requires more pull to open it under load.

To check a release for wear, put a finger on the jaw of the hook and try to wobble it to and fro in the opening and closing direction. This will give you a good idea of the amount of slack in the link pivots. Then wobble it from side to side. This shows up

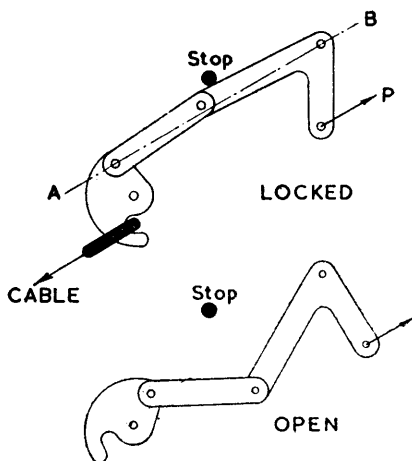

Fig. 10

any wear in the hook pivot. If in doubt, compare the amount of slack with that in a new or reconditioned release. See that the mainspring round the hook pivot inside the frame, and the back-releasing spring on the outside of the frame, are unbroken and have not become weakened. The mainsprings particularly are liable to weakening after long service, or they may break off one "leg". This can usually be detected by the flappy feel of the mechanism when it is operated without a winch cable in the jaw of the hook. The cure is, of course, to replace the mainspring. The other pivots and bolts should be examined for wear and security, but you are unlikely to run into much trouble here if the hook pivot is O.K. The hook pivot, and the link pivots, are the spots where wear always shows up first.

5. CONTROL SYSTEM AND CABLES, ETC.

THE control systems on nearly all gliders use cables. In many cases cables are used throughout, while in others we find push-pull rods and torque tubes in various places in the systems. We may well start this chapter, therefore, with a dissertation on cables.

The most widely used cable is 10-cwt. extra flexible cable. This consists of seven strands of nineteen wires in each strand. Eye-splices are made where the cable attaches to a turnbuckle or a fitting, though in some cases, notably Olympias, the turnbuckles and fittings are directly swaged into the cables. Previously we have discussed cable tensions, so we will not go any further into that subject, but will confine ourselves to the "ills that this steel coil is heir to".

Cables have three main enemies: corrosion, abrasion and fatigue. A corroded cable must be scrapped at once. The individual wires in the cable are very thin and any corrosion seriously weakens them. One of the best corrosion preventatives for cable is Lanolin Resin Solution D.T.D. 297B. This is a yellow sticky paint which is applied to the cable. It never dries out hard, but remains faintly "rubbery". It can be removed again when required with a petrol-soaked rag. A worn or abraded cable also must be scrapped if any individual wires are broken. The places to look for this are fairleads, pulleys, and the openings in bulkheads and frames. Abrasion is rather more difficult to deal with, since obviously the cable must rub against something somewhere. However, it will help if all rubbing places are kept clean and dry. This means not too much of the cable preservative at these spots and no lubrication whatever. Any attempt at lubrication merely results in the collection of grit particles, which then form a wonderful grinding compound with the grease or oil. This cuts the cable to pieces in no time. All fairleads and pulleys should be of fibre or plastic and no rubbing on unprotected wood or metal should be allowed.

The fatigue of cable is probably the most difficult problem to deal with. When a cable fatigues, the wires crack and break. The cause is always repeated bending round too small a radius, and manufacturers are often to blame for using too small a size of pulley

for the cable. Fatigue frays, in consequence, usually happen on the section of cable that runs over a pulley. If even only one wire has broken, the cable must be scrapped. This may seem drastic, but, if one wire has cracked, the others are all damaged to some extent and the cable cannot be trusted. Any rubbing place, such as a fairlead, is also a breeding ground for fatigue, since often an unsupported length of cable will vibrate in flight, and the fairlead is the place where bending due to the vibration occurs. There is no cure for fatigue other than to introduce modifications to the design to prevent it. All you can do is to inspect the cables frequently and, at the first sign of fatigue, scrap and replace the cable.

Splicing Cables

Sooner or later you are going to have to replace a cable, and this nearly always means that you will have to eye-splice the ends. Some machines, notably Olympias, have swaged ends to all the cables, and in this case you must buy a new cable from the makers unless you happen to have a swaging machine available. These machines are expensive gadgets and are unlikely to be found in the average gliding club.

Now splicing control cable is an art which is much best taught in a workshop by practical demonstration. However, for those who wish to teach themselves, here is how to go about it.

An eye-splice is always made round either a thimble or a bobbin. A thimble is a small metal lining to the eye, while a bobbin is a circular metal bush, usually intended to be fixed into the fitting or control horn by a clevis pin. The technique is exactly the same, though you will find that, since the bobbin is circular, it is rather more difficult to get the splice tight around it. See Figure 11.

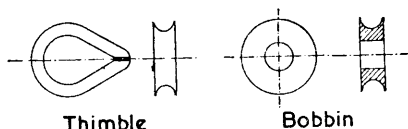

Fig. 11

Start by binding tightly round the cable a length of waxed thread. This binding

should be about $\frac{1}{4}$ in. to $\frac{3}{8}$ in. in length, and should be put on about 6 in. from the end of the cable. Its purpose is to allow the cable to be unravelled for 6 inches but no further. Now unravel the end of the cable. You will find that there are seven strands altogether—six outer strands somewhat wavy, and a middle one which is quite straight. This latter strand we call the heart strand because it lies in the heart of the cable. Unravel down to the binding and splay out the six outer strands somewhat, leaving the heart strand sticking straight out of the middle. Now wrap the cable round the thimble so that the splayed ends, where they disappear into the binding, lie just at the jaw of the thimble. Mark the cable at the other jaw and put on a similar binding just inside the other jaw. Wrap the cable round the thimble again and lash round cable and thimble tightly with string to keep it in place while the splice is made. This lashing will later be removed when the splice is finished. The joint now should look like Figure 12, with three outer strands lying each side of the parent cable and the heart strand along the parent cable.

Now the principle of making the splice is to weave the six outer strands back into the

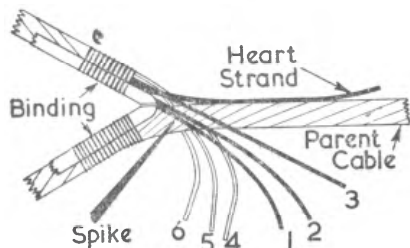

Fig. 12

parent cable, over and under each strand of it alternately, while the heart strand is pushed into the core to lie alongside the heart strand of the parent cable. Begin by pushing the spike into the cable at the point indicated and lift up one of the strands of the parent cable and push No. 1 strand through in the direction the spike went in. Remove the spike and pull No. 1 through tight. Pick up the next strand of the parent cable with the spike (the strand above as seen in the Figure) and do the same with No. 2 strand. Repeat the process with No. 3. Now slip the heart strand under No. 3 and push it down into the core of the

parent cable. Repeat the procedure of picking up the next parent cable strand and pass No. 4 under it. Do the same for No. 5 strand. Now, if we did the same for No. 6, it would have to go a long way round the parent cable before being spliced in. Therefore we adopt a different plan for this strand. It goes in the same place as No. 5, but passes under *two* strands of the parent cable. Pull all the strands down tight and you have done the first half-tuck of the splice.

Now inspect carefully. If you have worked correctly, there should be one strand coming out of each gap in the parent cable, and one only. Ignore the heart strand. Now, starting anywhere you like, take one strand, lead it over the next parent cable strand and put it under the next by using the spike. Follow round, doing the same with each strand in turn. When you come to the heart strand, simply ignore it. You only weave in the six outer strands into the parent cable, leaving the heart strand to lie inside the core of your splice against the heart strand of the parent cable. When you have done this over and under business with all six strands, you have completed one-and-a-half tucks. Pull down tight; inspect to see that one strand, and one only, emerges from each gap in the parent cable. After each tuck, after pulling tight it is a good plan to beat the splice gently with a mallet, or hide-faced hammer, on a piece of wood. This packs the splice down tight. Continue as above until you have a *minimum* of four-and-a-half tucks. When checking the number of tucks, select any strand, and, beginning at its loose end, follow it through the splice, counting as you go thus: under-over *one*, under-over *two*, under-over *three*, under-over *four*, under *four-and-a-half*. Cut off the loose ends of the strands, beat down and bind the finish of the splice with waxed linen thread. This binding should start at about the middle of the splice and finish on the unspliced parent cable. It *must not* cover more than half the splice, as this must be available for inspection. Remove the temporary lashing round the thimble and your splice is finished.

Now for some tips. A good splice is close, and tight, and it should be impossible to see daylight through it anywhere. To achieve this it helps if, each time a strand is threaded through, you take a little of the twist out of it. Also try to ensure that the spliced-in strands run round the parent cable with

approximately the same helix angle as the parent cable strands, but of course in the opposite direction. This means that the criss-cross effect is equi-angular, and the splice packs down tight properly. To stop the ends of the strands from unravelling when you are splicing, it is a good plan to twist the ends up with pliers. An even better scheme, if you have any acetylene welding gear handy, is to fuse the ends together by flashing them for a second in the blowpipe flame.

Splicing sounds quite easy. It is, when you know how. You will probably make several horrible wire birds'-nests in your first attempts, but don't be discouraged. It really *is* quite easy!

Hand splicing is rapidly being replaced by the system of swaged collars. These need a special machine to do the swaging, and the machine is expensive. However, the swaged splice is so neat, and can be done so quickly, that it has everything to recommend it.

Bearings and Hinges

Pulley bearings, stick, and torque tube bearings, may seem very simple things. Sometimes they are fitted with ball bearings, but more often they are plain bearings. Now, there is more than meets the eye in these bearings. They must be properly lubricated of course, but they must also be properly fitted and adjusted. In almost all of these bearings there is a replaceable element, whether it is a plain bush or a ball race. Figure 13 shows a cross section of a plain bearing in a pulley.

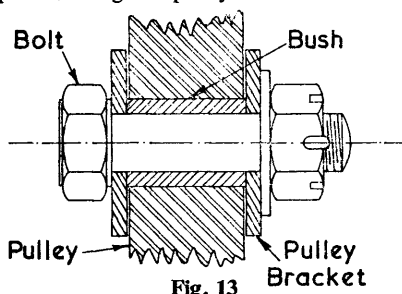

The first thing to realise is that the pulley is meant to rotate on the bush. This means that the bush must be quite a free fit in the pulley and also it must be long enough to project slightly each side of the pulley. Then we can bolt up tightly to ensure that the bush is nipped between the sides of the

pulley bracket and can *not* rotate. If wear occurs, we can easily replace the bush or the pulley or both. There is, however, plenty of bearing area between the bush and pulley, and so wear will be slow.

Now consider what happens if lubrication is neglected and the bolt is not properly tightened. The pulley may seize up on the bush. The bush will then probably rotate on the bolt, provided that the nip is insufficient to hold the bush fixed. The bearing area between the bush and bolt is much smaller and wear will be rapid. Worse still, the pulley, bush and bolt may seize solid and the whole issue rotate in the bracket. In these circumstances the bearing area is almost *nil*, being merely the thickness of plates of the pulley brackets multiplied by the diameter of the bolt. Wear will be extremely rapid and the holes in the brackets will wear elongated and the bracket and bolt will have to be scrapped.

The above applies equally to stick bearings. Where ball races are fitted, the same basic rules apply. The inner element must be firmly fixed in the bracket and the outer element must be properly attached to the rotating member, pulley, stick or whatever it may be. The usual way of doing this is to make the outer race a press fit in the rotating member, and to hold the inner race by gripping it endwise exactly like the plain bush in the above example.

Control surface hinges should be carefully watched for wear. Cleanliness and proper lubrication will delay wear in these parts, but when they do become worn they are very simple and cheap to replace with new items. It is usually a waste of time to ream and fit over-size pins. One point is very important. This is that at least one side of the hinge must be positively prevented from twisting round on its bolt in the spar. If this were to happen, so that an elevator hinge, for example, were to twist so that the axis of the hinge pin became vertical instead of horizontal, the control surface would lock solid. This would be unfunny in the extreme. The usual way of securing the hinge against rotation is to fit two small wood-screws through a plate which is attached under the head of the forked eyebolt. These screws are driven into the spar, and the hinge cannot then turn in the spar without shearing these screws. In consequence, these screws are very important items and must never be omitted.

6. FABRIC AND DOPE

Most gliders have much of their wing, tail and control surfaces covered with fabric. The fabric contributes nothing to the strength of the structure, but it is very important nevertheless, because it maintains the aerodynamic shape of the glider. On wings, etc., it transfers the lifting forces to the ribs, which in turn transfer them to the spars and thus to the fuselage. The strength of the fabric is therefore important, since, if it should rip or split in the air, it would spoil the efficiency of the aerofoil and might even lead to loss of control.

Fabric is sometimes used to cover plywood surfaces. In these cases the fabric is purely and simply a protective covering and a vehicle, or filler, for the dope or paint.

For wings and other flying surfaces two types of fabric are commonly used. The first is Madapolam, which is a cotton fabric. It is very light, and takes dope very well though it is rather liable to rot in bad conditions. The second type is a cotton fabric such as D.T.D. 275. This is somewhat heavier than Madapolam, but seems to resist rot considerably better. It usually outlasts Madapolam by a very big margin, provided that it is properly doped. It is also stronger. For covering plywood surfaces Madapolam is used, since strength does not matter, and the fabric is lighter.

Before we discuss repairs and re-covering of components, we must first clear up a few points about dopes.

Dopes are not paints, though some cellulose paints look and smell very like dopes. The purpose of doping fabric is to tighten it, make it water and air proof, thus preventing rot, make it opaque to prevent deterioration from ultra-violet light, and to give it a good smooth aerodynamic finish. We are not concerned here with the chemical composition of dopes, but it may be as well to note that different makes of dope do differ in composition and frequently will not agree. If you redope a piece of fabric with a dope different from the original, you may find that "pickling" or blistering occurs. For this reason, keep to one make of dope throughout for each job.

All dope manufacturers publish Doping Schemes, and fabric should always be doped in accordance with an approved Doping Scheme. A typical scheme for a wing might

be: Two stick-down coats of clear to attach the fabric to the timber, 3 or 4 coats of red tautening dope to tauten the fabric, build it up and fill the "grain" of the fibres: one or two coats aluminium dope, tautening or non-tautening, to make the surface opaque, followed by two coats of finishing colour, non-tautening, to produce the final high-gloss polished surface. The doping scheme used should always be quoted in the log book. This enables repairs to be made with the same scheme and thus eliminate the danger of using the wrong dopes with all the infuriating results, pickling etc.

Doping should be done in a warm, dry place, well ventilated. The first coat must be brushed on to get proper penetration of the fabric. Subsequent coats may be sprayed. Be careful not to inhale too much of the vapour. A mask is useful here and should be used when spraying. Drink some milk, the more the better, after doping, as this will neutralise any of the effects of the vapour. If you don't, you may find yourself with a lovely headache.

If the doping room is cold and damp, you may find a "bloom" forming on the doped fabric. This is a maddening trouble, and, while you can mitigate it somewhat by using Anti-Chill Thinners for the dope, there is no cure. You must stop and wait for warmer conditions, or stoke up the stove.

Lastly, do remember that dope is terribly inflammable. Carelessness in smoking, etc. can result in a beautiful bang, followed by a glorious bonfire! The doping of gliders and aeroplanes is virtually the same thing. The only real difference is that the degree of tautness aimed at in glider work is somewhat less, otherwise there is a danger of distorting trailing edges, etc. When it comes to fabric work, however, there are quite a few differences. On gliders no sewing of fabric, patches, tears, etc. is necessary. The low wing loading permits us to stick the fabric down onto the structure with dope alone. Similarly, no stringing of ribs is needed, unless the underside of the wing is very deeply cambered, when the fabric is sometimes stitched to the bottom booms of the ribs. Even this can often be avoided by loading the fabric down onto the ribs with books, magazines, etc., and carefully doping it onto the ribs. This dope is allowed to dry

before unloading the fabric. All these points make fabric work on gliders far easier than on powered aircraft.

The most usual job in fabric work is to repair a hole, or tear, in a wing. When you are satisfied that there is no damage to the internal structure, or that any repairs to it have been satisfactorily completed, proceed as follows: remove all spanners, screwdrivers, bolts and nuts, etc. that have been left inside the wing, tear away the damaged fabric to a rectangular hole, and prepare a piece of fabric which will cover this hole with about an inch overlap for holes up to 4in. x 4in. or two-inch overlap for longer patches. This patch must be of the same material as the wing fabric. With tautening dope, clear, and a brush, apply a coat of dope to one edge of the hole and dope down one edge of the patch, taking care that the overlap is correct. Allow this dope to dry, and then repeat the procedure along an adjacent edge. The other two edges can then be similarly treated and allowed to dry. The patch should then be redoped around the edges and allowed to dry again. The idea is to get all edges firmly doped down and stuck before doping the middle of the patch. The undoped middle portion should now look nicely taut and smooth, and you can stroke in the first coat of dope with the brush evenly all over it. This will nearly break your heart because the patch will now look a horrid, saggy mess. Fear not: press on with the doping scheme, allowing each coat to dry before the next is applied. You may have to apply a coat or two more, or less, than called for in the doping scheme. The aim is to get the patch to the same tension as the main fabric, and "built up" or "filled in" until it has the same texture. Use tautening, or non-tautening, dope, depending on whether tautness, or filling in, is required. Finish with the colour scheme. A high gloss can be obtained by rubbing over the patch with a rag moistened with dope thinners. Remember that doped fabric will go on tautening very slowly for a day or so after doping. Properly applied, a patch can be made almost invisible. It will help to this end if the patch can be cut with pinking shears, or if these are not available, the patch should have its edges frayed for about $\frac{1}{8}$ in. all round.

Covering a main component, such as a wing, is basically the same process. The structure should first have two good coats of clear tautening dope applied all over where

the fabric is to stick. Dope down the fabric on a long edge first and allow to dry. Now stretch the fabric over the whole surface and fix it in place. Drawing pins are very useful here. When you have it tight and smooth all over, dope all round the edges and along each rib to stick the fabric into place. Trim edges, redope all round again and over ribs, etc. and allow to dry. The edge should be lapped round the trailing edge and similar places. Now turn the wing over and repeat the procedure on the other side. You can then go ahead according to your approved doping scheme. All laps round trailing edges, etc. should be covered with a 2 in. strip of fabric with frayed or pinked edges. Tips to bear in mind: do make sure that all traces of old fabric are removed. If the old fabric was very rotten, this can be quite a long job, as it tends to stick to ribs, etc. and may have to be sanded off. If the old fabric was not too bad, it may tear off the ribs and trailing edges, etc. in strips, so don't let the fabric get too bad before you decide to re-cover. Do ensure your new fabric is really dry before you start. It is a good plan to put it out in the sun (if any) for an hour, while you are getting things ready, to allow it to air thoroughly. When brushing in the first coats of dope, don't press heavily but stroke the dope in with gentle, even strokes. Heavy pressure tends to stretch the fabric and makes the tautening process rather uneven. Each subsequent coat of dope will appear to relax the tension when applied, but don't worry about this as the tension will reappear again, tighter than before, as the coat dries off.

Applying fabric to ply-covered surfaces is a little different. Dope all over the ply first and allow to dry. Now stretch the fabric as tightly as possible over the fuselage, or whatever it is that you are covering and brush in the dope, following up with a rubbing pad of fabric to rub the dope through the fabric on to the ply. Use drawing pins if necessary and do the above jobs with clear tautening dope. Most manufacturers have approved doping schemes for ply-covered surfaces and one of these should be followed. All joins in the fabric should be trimmed to edge-to-edge butt joints and then covered with 2-in. frayed edge, or pinked strip. Once the fabric has been properly "filled in", the surface can be worked up to a really high-gloss finish. You can get liquid filler dopes which make the filling-in process much

quicker. This process does give a magnificent protective covering to the plywood of a fuselage and it must also add a little to the strength. It is true that it is a little heavier than ordinary paint, but the lovely finish is a joy to behold.

Tips to remember when doping:—

Make sure that the initial "stick down" coats of clear dope really do stick. This is greatly helped if you rub the dope in with a small pad of fabric over all ribs, ply surfaces, etc. so that it is properly squeezed through the fabric onto the wood below. This also eliminates air bubbles under the fabric.

The first coats on a patch or a newly covered component may feel a little rough to the touch. If so, touch them down with a fine abrasive paper. This will make a vast difference to the final finish.

Brushes get into a horrid state if they are not properly cleaned in thinners. A very good plan is to keep brushes in one of those big sweet jars that confectioners use. Put a few inches of thinners in the bottom and drop the brushes in. They will stay soft and

in good condition, and the thinners will not evaporate provided you keep the lid screwed down tight. As these jars are of glass, you can see at a glance where the particular brush you want is hiding.

Perspex canopies sometimes develop cracks through mishandling or damage. To stop cracks from spreading, drill a small hole, about $\frac{1}{8}$ in. or so, at the extreme end of the crack. A patch should then be made and stuck over the crack, using one of the many proprietary brands of perspex cement. While on this subject, it might be as well to point out that you may come across canopies which are not made of perspex at all. There are now a variety of transparent plastics, and if in doubt, it is always worth while to refer to the manufacturers for advice. Any patches should of course have their edges chamfered down, and it is neater to fit them inside the canopy if this is possible.

A good perspex cement can be made up by dissolving some perspex chips in chloroform, or glacial acetic acid.

Yorkshire Gliding Club

SUTTON BANK · THIRSK



Full facilities for the repairs
and maintenance of Club
and Private owner Sail-
planes.



Write to the
Secretary for quotations

JOHN HULME

MOTOR BODY BUILDER

RATHMORE ROAD, CAMBRIDGE

B.G.A. APPROVED INSPECTOR

Phone: CAMBRIDGE 87862

For all repairs, overalls,
C of A's and materials.
Trailers built to order.
A'C Bought and Sold.

7. TYPES OF CONSTRUCTION AND INSPECTION FOR DAMAGE

BELOW we can deal with the matter of inspecting a glider for damage we must first have some idea of how the machines are built and what each part of the structure is meant to do. Gliders can be roughly subdivided into three main types: two-spar, strutted single-spar and cantilever. This classification applies to the wings. Fuselages and tail units we will deal with later.

The classic example of two-spar construction is the Slingsby Tutor. Each wing has two spars running spanwise and each spar has its own strut. All the lift force is taken by these spars in bending and the loads are transmitted to the fuselage by means of the struts. To brace the wings in the fore-and-aft direction (drag bracing) there is a system of diagonal members inside the wing, connecting the two spars. There are also crossed wires bracing the two struts. Thus braced, the wing clearly cannot twist, for if it did it would have to move forward or backward, and this it cannot do because of the diagonal bracing and the strut wires.

The fuselage of this aircraft is a plain box of ply with four longerons of spruce and a number of frames to stiffen the sides and to preserve the correct shape. The top of the box is not covered with ply, but has a light triangular fairing covered with fabric to give the whole a good streamline form. This triangular top is only a fairing, but it must be realised that all the rest of the fuselage, ply sides and bottom and longerons, frames etc., is the main load-carrying structure, and no damage to this can be tolerated if the aircraft is to be considered airworthy.

The tailplane is a simple triangle with a leading-edge member or spar on each side and a main spar running from tip to tip. The main spar's chief job is to carry the elevator. The tailplane is attached to the fuselage by two bolts, one at the joint of the leading-edge members, and one at the midpoint of the main spar. These bolts are anchored to frames in the fuselage. The main spar is also stabilised sideways by two small struts to the fuselage frame.

Struts and wires are expensive in drag. To secure greater efficiency the struts must

go, or at least two of them. This brings us to the next type of construction.

The single-spar strutted type is typified by the T-21, Kites I and II, Gull I, Grunau Baby, etc. In this form the wing is built with one massive spar which is placed at about a third of the chord from the leading edge. This is about the average position of the Centre of Pressure for most normal conditions of flight. This great spar takes all the lift forces in bending and transfers the load to the fuselage through one single strut on each side of the aircraft. This spar and strut, however, have almost no stiffness in twist, so something else has got to be added to stop the wing from twisting.

Now the stiffest thing, weight for weight, in twisting is a tube; so the leading edge of the wing is made a wooden tube by forming it out of ply glued to the spar. It is a "D"-shaped tube, it is true, and not a circular shape which we usually assume a tube to be; but it is a tube for all that, and it is enormously stiff in twisting. To deal with the bracing in drag we usually find that at the root of each wing there is a big diagonal, sometimes called the drag spar, which connects up to the fuselage via the rear fuselage pin and runs diagonally forward to join the main spar a few feet out from the root. Usually the triangle formed by the root rib, main spar and drag spar is completely covered over with ply. Outboard of this junction of main spar and drag spar, the drag forces are dealt with by the leading-edge ply tube. This tube is stiffened all along its length by many nose ribs which also ensure the correct aerofoil shape. It will now be obvious that this tube is a vital part of the structure, and it is of the first importance that there should be no damage here. Should any damage be found, the tube cannot do its job properly and the aircraft is not airworthy until the damage has been made good.

Fuselages in this type vary a good deal from a wooden girder as in the T-21B, through various shapes of ply box fuselages to the round or oval section monocoques. These last are pure ply tubes, stiffened where necessary by frames, and by longerons or stringers running lengthwise.

From here it is a simple step to the third type of sailplane construction which is—

The Cantilever Wing

In this type, instead of hinging the wing on to the fuselage and then holding it there by means of a strut, we simply beef up the spar at the root end and connect the spars of each wing together rigidly so that the main spar can be considered continuous from tip to tip. The fittings in the joint of the two wings do take enormous bending loads, so they have to be very big and strong. In consequence, this type of construction is somewhat heavier than the other two types, but this is far outweighed by the gain in aerodynamic efficiency which results from the deletion of the struts. The leading-edge ply tube is there, and it does exactly the same job as before, dealing with the twist and drag forces. Also we find our old friend the drag spar in the root, and the ply triangle boxing-in the root, mainspar and drag spar. Fuselages in these types are usually pure monocoques, for reasons of aerodynamic efficiency. Tailplanes are often mounted as cantilevers, though a few types still use tailplane struts.

The three-piece wing, which has come into favour lately, merits a word. It is a cantilever just as before, but it has two joints outboard instead of one joint in the middle. The construction of the wing, however, is basically the same: one spar, leading-edge ply tube, etc. It is a little deceptive at first sight, since these sailplanes often use a laminar-flow wing section, and this necessitates the use of ply covering to guarantee the surface finish required. This ply masks a lot of the structure which would otherwise be fairly easy to detect.

One peculiar type must be mentioned, and that is the Slingsby Prefect. This is a half-and-half type of construction. There are two spars in each wing, but they are so strongly braced together by stout diagonal members that they can almost be considered to be one spar. They are so stiff in twist, like this, that only one strut is needed, and, although the wing has a leading-edge ply box or tube, this does not by any means take all the twisting loads.

Having acquired some knowledge of what holds the things together, we can now go on to discuss the subject of inspection for damage.

Now, the usual cause for this inspection

is when the machine has been subjected to some unusual strain, such as a heavy landing, or when it has been involved in a crash. The first thing to do is to find out, if you can, just exactly what happened. If you can do this, you can then work out what parts of the structure have taken the worst pasting. For instance, a machine may have received a heavy landing by touching lightly on the wheel, rising to four or five feet and then pitching on to its nose. In this case you might well find that the drag bracing was damaged and some of the front frames in the fuselage crushed. On the other hand, a heavy landing may well mean stalling on to the ground from four feet and hitting tail-skid first. In this case you are much more likely to find crushed main bulkheads in the fuselage, torn-out aileron horns, and compression shakes in the top longerons. In case the expression "compression shake" is strange to you, it may be as well to say now that we shall go into this more thoroughly later on. The next thing to remember is that you must trace the path of the impact through the structure and follow along each member looking for damage. Never forget that, although the impact came on one end of a member, you may well find the damage at the other end. A longeron, for instance, may get a bash at the tail end from a tail-first landing, but the damage may be right up near the wing where you may find a compression shake.

Now, what sort of damage do you look for? Well, timber, when it fails in tension or in shear, simply breaks or splinters. The damage is obvious. However, when it fails in compression you may simply find a compression shake. These compression shakes are often very difficult to detect. Often the only visible sign is a hair-line crack in the paint or varnish, running across the grain of the wood. If in doubt, you can always find out whether a suspicious-looking mark is a compression shake or not by a little judicious bending or twisting of the member. If it is a compression shake, the crack will open. How does a compression shake occur? To answer this we must first look at the structure of timber itself. An ordinary piece of timber consists of a bundle of fibres running lengthwise, bound together by resinous substances (Fig. 14a). When the timber is compressed beyond its elastic limit (Fig. 14b), the fibres simply fold over for a short length and double back on them-

selves. Needless to say, the timber is now useless and must be replaced.

Other signs of damage you may find are: pulled fittings, stretched holes in fittings,

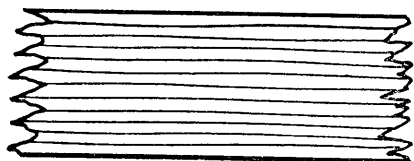

Fig. 14a

and the fittings themselves moved on their timbers. This last is usually easy to see, as the paint line will show where the fitting was before it shifted. If you find a bracing wire slack, it is almost a certainty because its attachments or the surrounding structure have shifted. Slack control cables also nearly always mean that a fitting some-

where in the circuit has been pulled out of shape or wrenched adrift from its mounting. Go through the circuit from end to end until you find the damage. As a general rule, it is much quicker and better to replace fittings with new ones rather than to try to repair or reclaim damaged ones.

Compression Shake

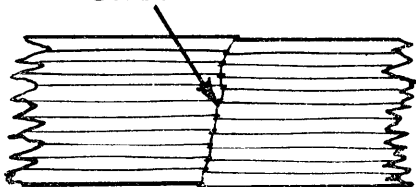

Fig. 14b

GLIDING BOOKS AND EQUIPMENT

Gliding Handbook <i>by</i> A. D. PIGGOTT	25/-
The Soaring Pilot <i>by</i> A. AND L. WELCH	18/6
World Sailplanes <i>by</i> OSTIV	17/6
Further Outlook <i>by</i> LUDLAM AND SCORER	15/-
Playground in the Sky <i>by</i> A. F. GOTCH	12/6
Cloud Study <i>by</i> R. S. SCORER	12/6
Come Gliding with Me <i>by</i> A. WELCH	9/6
Cloud Reading for Pilots <i>by</i> A. WELCH	7/6
On Being a Bird <i>by</i> PHILIP WILLS	5/-
Elementary Gliding <i>by</i> P. BLANCHARD	5/-
F.A.L. Regulations for Records	2/6
Personal Logbooks	2/- and 4/-
B.G.A. Operational Regulations	1/-
Aircraft Logbooks	7/6
<i>and</i>	
Scarves	23/-
Chokers	15/-
Gliding Ties	12/6
<i>(All navy blue with silver stripes and gliders)</i>	
Car/bicycle badges	12/6
Blazer badges	5/6

from

The British Gliding Association, 19 Park Lane, London, W.1

Telephone: HYDe Park 3341

8. THE C. OF A. OVERHAUL AND WEIGHING OF GLIDERS

The Certificate of Airworthiness of a glider lasts for twelve months, and may be renewed for a similar period on application to the British Gliding Association, together with the renewal fee, and a certificate, on the proper form, signed by a B.G.A. Approved Inspector, that the machine is airworthy. This latter involves a complete inspection of the machine, and it is the purpose of this chapter to give an outline of what this involves. Apart from the inspection of the machine as it stands, there are some items which must be removed, or stripped, for inspection.

There is some misconception about Approved Inspectors in some quarters. The Inspector is a man who is qualified to pass, or condemn, a part of a glider, or to pass, or condemn, any work carried out on it. The work itself may be carried out by anybody, but it must subsequently be inspected and certified as O.K. by an Approved Inspector. This means that a Private Owner is perfectly at liberty to do his own C. of A. overhaul on his own glider, provided that he gets his work inspected and approved by an Approved Inspector. Many Private Owners do just this, and the usual way of going about it is as follows:—

When the C. of A. is soon to expire, an Approved Inspector is contacted and asked to do the inspection. The machine is prepared by removing all inspection panels, etc. The Inspector makes a thorough examination of the whole machine and its log book, and writes down all the repairs, snags, etc., which he deems necessary. The Owner can then carry out the work, and when he has finished it he contacts the Inspector again. The latter then inspects all the work done and satisfies himself that it has been properly done. He then ensures that the logbook has been correctly made up, listing all the repairs carried out. If he is quite satisfied he signs the log book entries, and recommends the renewal of the C. of A.

Let us assume that you have a glider whose C. of A. you want to renew. Before you do anything else, make sure that the log book is up to date, and that all repairs have been signed up by an Approved Inspector, or you may find that these repairs will have to be opened up and the

work re-done. Have the machine ready for the Inspector, with all inspection panels off and the seats out, and try to arrange lights so that the whole machine can be easily examined. Assuming that the glider is in reasonable condition, the list below is a rough outline of the work you can expect to have to do:—

All fittings will be checked for corrosion, and any found must be cleaned off and the fittings repainted.

All main pins, hinge pins, control pins, etc. will be checked for wear and replaced where necessary.

All control cables must be drawn, inspected and re-protected. Any damaged ones will have to be replaced.

All fittings will be examined for security. The whole structure of the machine will be examined for soundness, and any suspicious joints or bad timber made good.

The fabric covering will be checked for condition and will have to be renewed where necessary.

All protective coatings will have to be made good.

The instruments will have to be checked, and the A.S.L. calibration verified. All perished rubber piping will have to be replaced.

The release hook will probably have to be overhauled.

The wheel, tyre, skids and skid rubbers will have to be checked and replacements fitted where necessary.

The Inspector may also require the glider to be re-weighed.

The weighing of a glider is not a difficult matter, provided the equipment is at hand. You will need two big spring balances, or steelyards, a measuring tape, some rope slings, and a good strong overhead beam from which to suspend the glider. Before we start, however, it might be a good idea to get quite clear what we are after, with all this weighing racket.

The glider is weighed for two reasons. First, we want to find out the empty weight of the glider so that we can determine, knowing the maximum permitted all-up-weight, what payload the glider can carry. Second, and this is rather more important, we want to find out where the Centre of Gravity of the empty glider is. This is

vitally important because, in the C. of A. document, you will find the maximum forward and aft positions of the Centre of Gravity (C.G. for short) for the loaded glider are laid down in the C. of A. document. It is necessary to know the position of the Empty C.G. before the position of the Loaded C.G. can be worked out for various loads. You will find that the Empty C.G. position is stated in the C. of A. document, but this will be affected if any large repairs have been done, or the machine has been refabricated; and in these cases the machine must be re-weighed and the new Empty Weight and Empty C.G. position determined. By the way, you must not alter the C. of A. document yourself. You must supply the B.G.A. with the information and they will do the alteration.

So far, so good. Now to the actual weighing. Hang up your two spring balances to the overhead beam, move the glider into position under them, and by means of the rope slings, hang the glider on the balances. Adjust the length of the ropes until the glider is in flying attitude. As a rough guide to this, get the lower surface of the wing as near the horizontal as you can. In the C. of A. document you will find the C.G. is always referred to as so many inches forward or aft of a Datum Point and this Datum Point is defined. The most usual Datum Point is the leading edge of the wing at the root. We will assume that this is the Datum Point for the glider we are considering. Read the weights indicated on the spring balances, subtracting, of course, the

weights of the rope slings, etc. Also measure the distances of the slings from the Datum Point.

Referring to Fig. 15, let A lbs. be the reading of the nose balance and B lbs. be that of the tail balance. Also let a and b inches be the distances, respectively, of the two slings from the Datum Point.

The Empty weight, W is clearly $A + B$ lbs. Now the position of the Empty C.G. is x inches aft of the Datum Point, and x is the dimension we want to find. Since the glider is in equilibrium, all the clockwise and anti-clockwise moments exactly balance. It does not matter what point we choose to take moments about; the result will be the same. However, the calculation is easier about some points than others. Let us use the sling A for a start. Taking clockwise moments on the left, and anticlockwise moments on the right of the equation, we get:—

$$W(x + a) = B(a + b)$$

$$\text{Therefore } x + a = \frac{B(a + b)}{W}$$

This gives us $x + a$, and, since we know the dimension a , we can find x by subtraction.

This is not quite the whole story, though. We know now the maximum load the glider may carry. It is All-Up Weight minus Empty Weight. We ought to check the C.G. position when a pilot of this weight is in the cockpit. With most ordinary types of glider, increasing the pilot weight moves the C.G. forward, because the pilot sits well

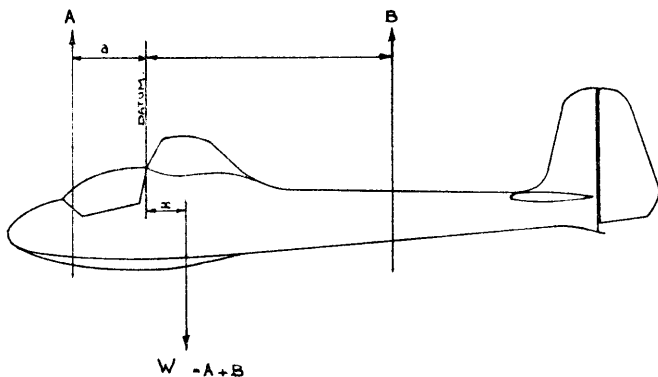

Fig. 15

forward of the empty C.G. If, with the maximum pilot weight in the cockpit, the C.G. is between the limits, then all is well. If it is not within limits, then we must determine what pilot weight brings the C.G. up to its forward limit. Any pilot heavier than this must carry ballast on the tail, to keep the C.G. within the limits.

To check C.G. position at Maximum Pilot weight we proceed as follows:—

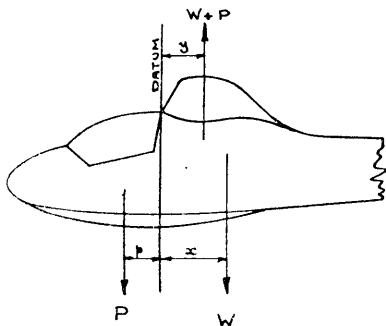

Fig. 16

In this figure:

- P = Max. Pilot Weight (A.U.W.— W)
- W = Empty Weight of Glider
- x = Empty C.G. Distance from Datum Point (which we have just found)
- p = Pilot's C.G. Distance from Datum Point (which is given in the C. of A.)
- y = the loaded C.G. position which we want to find.

We know all these quantities except y . If we imagine the glider hanging by a rope attached to its loaded C.G., it will exactly balance, and this rope can be represented by the arrow $P + W$. The tension in the rope is clearly $P + W$ which equals the All-Up Weight (A.U.W.).

Take moments about the Datum Point:

$$Wx = (P + W)y + Pp$$

$$\text{Therefore } y = \frac{Wx - Pp}{P + W}$$

This gives us y . If this comes between limits, then all is well. If it does not, then we shall have to investigate further. Before

we do so, we will check the minimum pilot weight. This may be an odd thing to do, but the reason will become obvious later.

Checking for Minimum Pilot Weight is a little different from the last two checks. In this case we know all the *dimensions* and are trying to find out a *weight*. Assume we have got a pilot, of unknown weight, in the cockpit but that the C.G. position is on the aft limit.

Draw a diagram like Figure 16.

This time take moments about the C.G.:

$$W(x - y) = P(y + p)$$

$$\text{Therefore } P = \frac{W(x - y)}{y + p}$$

From this we can find what Pilot Weight P gives us the maximum aft C.G. position.

It should be clear now why we have considered the Minimum Pilot Weight case before discussing the Maximum Pilot Weight case where the C.G. comes out in front of the permitted forward limit. All we have to do in this latter case is to repeat the above check, using the forward limit for y instead of the aft limit. This will give the Maximum Pilot Weight that can be carried unless ballast is fixed to the tail of the glider.

All the details of Empty Weight, Maximum All-Up Weight, Maximum and Minimum Pilot Weight must be displayed on a placard in the cockpit. The best plan is to position this information beside the Flight Limitations Card, in the cockpit. By this means the pilot has all the information which he must know about the glider, presented to him in one place instead of having to search around the cockpit for the facts on which his life may well depend.

Parachutes

second-hand Nylon canopy, new glider back-type pack and harness.

£31. 12. 6d.
(incl. new bag)

from

British Gliding Association,
19 Park Lane, London, W.1

APPENDIX I. B.G.A. FORMS

ONE of the curses of civilisation is the multiplication of forms and paper-work that seems to surround every activity. Gliding is no exception, but the forms, etc. are not so very numerous, and when properly understood, they can actually save you time.

The first form is the Certificate of Airworthiness of the Glider, which we can call Exhibit A. This is the Birth Certificate of your glider and on the front page are all the details of when, where, and by whom the glider was built. Also on page 1 of the Certificate, usually called the C. of A. is the name of the Owner of the machine. Turning the page we find a series of dimensions of the aircraft and a list of the maximum and minimum weights that the machine may carry. Items 19 to 21a are concerned with the Centre of Gravity Position and these details are of vital importance. If the machine undergoes any large repairs it will have to be reweighed and the position of the empty C.G. as listed in Item 21 will almost certainly be found to have moved slightly. This will mean that the Max. and Min. weights, Items 20 and 20a will have to be revised. You may *not* alter these figures yourself, but you must send the results of your weighing to the B.G.A. and they will make the necessary amendments. The B.G.A. will usually want the results of the weighing signed up by an Approved Inspector, and his calculations of the new Max. and Min. weights.

You may feel that we have spent rather a long time talking about this business of C.G. but it is important. It is literally of vital importance. The consequences of flying a glider with the C.G. outside the limits may well result in death.

Proceeding farther, we find a list of the speeds that the machine may not exceed in various states of flight, and some information on what the machine may or may not do in the way of aerobatics and cloud flying. These items have to be displayed in the cockpit of the gliders as also do the items about the C.G., but more of this later.

The last page of the C. of A. is mainly taken up by a table which gives the validity of the C. of A. and when it next expires. There are also some admonitions to the

effect that you must not alter anything in the Certificate yourself, that you must not exceed the stated limitations of the glider, and that you must notify the B.G.A. if you take the glider out of the U.K. at any time.

The B.G.A. have a duplicate of your C. of A. at the London Headquarters, but take care of your Certificate because it is an important document.

Now, no reputable Club in this country will allow you to fly your glider at their site unless the C. of A. is valid and has not expired. It may be a nuisance to have to produce the C. of A. document every time you wish to establish its validity, so, when the C. of A. is renewed, the B.G.A. will send you a small card, which we may call Exhibit B, which must be fixed in the cockpit and states the expiry date of the C. of A. Do not think, therefore, that when the Manager or C.F.I. of a strange Club asks to see your cockpit card, that he is merely being officious. He is safeguarding, not only the reputation of his Club, but your continued well-being also.

You may well want to fly directly the C. of A. overhaul has been completed, and to enable you to do this, the B.G.A. have provided a temporary card, coloured orange, which the Inspector may fill in and fix in the cockpit, to tide you over until the C. of A. is received back from the B.G.A. This card is shown as Exhibit C. It is also known as Form Insp/3.

Now, as stated above, the information on speeds, weights, etc., has to be displayed in the cockpit of the glider, and to save you trouble, and also to provide this information in more or less standardised form, the B.G.A. have devised standard placards for this purpose.

The first one, Exhibit D, contains the Flight Limitations section from the C. of A. and is applicable to all gliders. When we come to weight limitations there is a further complication in that there are tandem two-seaters to consider. So, for all single seaters, and two-seaters where the pilots sit side by side, we use the card shown as Exhibit E. In these types all the disposable load in the way of pilots is put into the glider at one particular point, so all we are concerned with is whether or not this total weight is within the limits allowed. From

the point of view of tandem two-seaters, however, we have two separate points where this load can be applied; the front cockpit and the rear. Clearly, the Centre of Gravity is affected, not only by how much weight we put into the glider, but also by where we put it in. To avoid complicated graphs, etc., the B.G.A. has devised the second Loading Limitations card, Exhibit F. This assumes that the glider can only be flown solo from the front cockpit, which is true of all gliders of normal configuration. On the left-hand side of the card is a table of various weights of Rear cockpit load, and against each value is the Max. and Min. load that the Front cockpit can carry. If these figures are not exceeded then the C.G. of the glider will be within the correct limits.

The above are all the forms that you are likely to meet in the course of everyday flying. There are some others, however, and the first of these is the INSP/2 form, Exhibit G. This is the form that the Inspector uses when he has overhauled your glider and is recommending it for renewal of its C. of A. to the B.G.A. The front page is taken up by, at the top, a few details of the aircraft itself, and, lower down a list of various parts of the glider and what has been done to them to bring the glider up to scratch. On the reverse side of the form are some things that the Inspector has to certify that he has done. These are mostly self-explanatory, but one of them does require a little elaboration. You will notice that the Inspector has to certify that the glider was last weighed on such and such a date and that, since then, no repairs or modifications have been carried out which appreciably affect this. If any such repairs or modifications have been carried out, then the glider has got to be re-weighed, and in this case the Inspector has to fill in the results of the new weighing at para. g(2). The B.G.A. will not renew the C. of A. unless they are satisfied on this point.

You may, one day want to get Approval

from the B.G.A. so that you can exercise the powers of an Approved Inspector, and overhaul your own, or other people's gliders, and recommend them for renewal of C. of A.

In this case you will have to make application to the B.G.A., and you do this on the form INSP/1, Exhibit H. This is a fairly simple form with a long list of questions to be answered. They are mainly concerned with your previous experience on aircraft. Two items do perhaps need a little explanation, and these are the Section E of the British Civil Aviation Requirements, and A.P.2662A. The Air Registration Board have drawn up a list of Requirements to be met by all British aircraft. These Requirements are split up into Sections on Aeroplanes, Engines, Radio, Licensing, Safety Harness, etc. Section E is the one which deals with gliders and you should get hold of a copy. It deals, not only with the requirements in the way of the strength of the machines, but also in the matter of handling in the air, and various other aspects affecting the safety of the machine. It can be obtained from H.M.S.O. The A.P. 2662A we have discussed earlier on in this book, but you will find it an invaluable help. It is Restricted, so you cannot just walk into a shop and buy it. The B.G.A. will get you a copy, however, if you apply to them. In it you will find no end of useful information, and various worked out schemes for repairs. Almost every repair you are ever likely to have to tackle can be found in this book if you are prepared to use your intelligence by selecting a piece of this Scheme and a piece of that Scheme to fit the particular job you are repairing.

Well, there you are. Not such a formidable list really is it? Remember, a lot of thought has gone into the preparing of these forms to cut out all the unnecessary paper work, and if you use them with intelligence you will find that they do save you time and trouble.

Exhibit A.

BRITISH GLIDING ASSOCIATION GLIDER

CERTIFICATE OF AIRWORTHINESS No.....

1. Type of Glider.....
 2. No. of Seats.....
 3. Year of Construction.....
 4. Constructor's No.
 5. Constructor
 6. Address of Constructor
 7. Place of Construction.....
 8. Owner/s
 9. Address of Owner/s.....
 10. Changes of Ownership
- (See Notes 1 & 2 back page)

Exhibit A.

11. Classification
(Non-Aerobatic/Semi-aerobatic/Aerobatic/Cloud-Flying/Non-Cloud Flying)

12. Maximum Span..... ft.....ins.
13. Maximum Length ft.....ins.
14. Total Height ft.....ins.

15. Weight Emptylb.
- 15A Permanent Ballastlb.

16. Max. Permissible Load.....lb.
- 16A Min. Permissible Load.....lb.

17. Max. Total Weight Authorised.....lb.

18. The Datum point is defined as.....
.....

19. The Centre of Gravity at all flying weights to be within the limits.....
and.....aft of the datum point.

20. When flown by pilots weighing less than.....lb.
(including 20lb. parachute if worn) ballast must be carried securely attached to the
seat/nose to maintain the horizontal position of the centre of gravity within the
prescribed limits.

- 20A When flown by pilots weighing more than.....lb.
(including 20 lb. parachute if worn) ballast must be securely attached to the glider in
an approved manner to maintain the horizontal position of the centre of gravity within
the prescribed limits, but the maximum total flying weight must not exceed
.....lb.

21. In the weight empty condition of Item 15, the horizontal position of the centre of
gravity is.....
aft of datum.

Exhibit A.

21A The horizontal position/s of the centre/s of gravity of the pilot/s may be taken as :

Front Pilot/s.....aft/forward of datum

Rear Pilot.....aft/forward of datum

THE FOLLOWING DETAILS MUST BE CLEARLY PLACARDED IN THE PILOT'S COCKPIT AND BE VISIBLE TO THE PILOT IN THE FLYING POSITION

The following indicated air speeds must not be exceeded : (Units : knots, m.p.h., k.p.h.)

22. Aero-tow 25. Air Brakes Open.....

23. Winch-tow 26. Air Brakes Closed.....

24. Auto-tow 27. In rough air.....

28. The above indicated speeds are related to the following airspeed indicator

installation:—Pitot..... Static.....

29. The breaking load of the weak link in the towing cable must not exceedlbs.

30A The glider { is not permitted to undertake cloud flying
is permitted to undertake cloud flying when fitted with an altimeter and
a turn and bank indicator.

30B Aerobatic manœuvres are not permitted/The following aerobatic manœuvres are permitted

31A Any major repairs or modifications to this glider which are not certified by a B.G.A. Approved Inspector or by a member of B.G.A. Approved Repair Organisation will invalidate this Certificate.

31B The following items are to be placarded on the glider:—15, 16, 16A, 17.
The following items are to be placarded in the cockpit so that the pilot can easily see them in the flying position:—22, 23, 24, 25, 26, 27, 28, 29.

Exhibit A.

- 31c The British Gliding Association must be notified if this glider is at any time taken outside the United Kingdom.
- 31d This certificate is only valid subject to the operational limitations stated hereon not being exceeded.

This Certificate is valid for the periods shown hereunder.

for THE BRITISH GLIDING ASSOCIATION.

Date of Issue..... *Secretary.*

Certificate valid		Date	Signature
From	To		

- Notes* :—1. NO ENTRIES OR ENDORSEMENTS MAY BE MADE ON THIS DOCUMENT, EXCEPT BY THE BRITISH GLIDING ASSOCIATION.
2. THIS CERTIFICATE MUST BE RETURNED TO THE BRITISH GLIDING ASSOCIATION WHEN : (a) A renewal is required. (b) The glider is written off or (c) on change of Ownership.

THE BRITISH GLIDING ASSOCIATION
Londonderry House,
19, Park Lane,
London, W.1.

Exhibit B.

**BRITISH GLIDING ASSOCIATION
CERTIFICATE OF AIRWORTHINESS**

No.....

Valid to.....

Exhibit C.

INSP/3

BRITISH GLIDING ASSOCIATION

Glider No.: B.G.A.....
I have completed the C of A inspection on this aircraft and the application for Certificate of Airworthiness is being made.

Signed.....

Insp. No..... Date.....

Exhibit D.

FLIGHT LIMITATIONS

GLIDER No. B.G.A.....

CATEGORY: Non-Aerobatic/semi-Aerobatic/
Aerobatic

**THE FOLLOWING INDICATED AIRSPEEDS
(knots/mph/kph) MUST NOT BE EXCEEDED:**

WINCH LAUNCH.....
AUTO TOW LAUNCH.....
AERO TOW LAUNCH.....
AIR BRAKES OPEN.....
AIR BRAKES CLOSED.....
IN ROUGH AIR.....

CLOUD FLYING is/is not permitted provided Altimeter and Turn & Slip Indicator are fitted. The following manoeuvres are permitted :- **LOOP, STALL TURN, TIGHT TURN (3½g.), SPIN.**

Breaking load of weak link in towing cable not to exceed.....lb.

The above speeds are related to the following pitot static installation :.....

Exhibit E.

LOADING LIMITATIONS

GLIDER No. B.G.A.....

Empty Weight lb

Max All-Up Weight lb.

The C.G. is within the permitted limits if the loading is as follows :—

MAX. COCKPIT LOAD lb.

MIN. COCKPIT LOAD lb.

Ballast must be carried forward/aft if cockpit load is less/more than.....lb., but the Max. All-Up

Weight must not be exceeded

Exhibit F.

LOADING LIMITATIONS

GLIDER No. B.G.A.....

Empty Weight lb.

Max. All-Up Weight lb.

SOLO FLYING FROM FRONT COCKPIT ONLY

The C.G. is within the permitted limits if the loading is as follows :

Rear Cockpit Load lb.	Front Cockpit	
	Max. Load lb.	Min Load lb.
0
100
120
140
160
180
200
220
240

Exhibit G.

THE BRITISH GLIDING ASSOCIATION

B.G.A. Form No. INSP/2.

INSPECTOR'S REPORT FOR RENEWAL OF CERTIFICATES OF AIRWORTHINESS

Type of Glider..... B.G.A. No.....
 Constructor.....
 Constructor's No. Date Built

Date of expiry of previous C. of A.
 Owner's Name and Address

.....

<i>Item</i>	<i>Condition before Overhaul and Action Taken</i>
1. Timber
2. Glued Joints
3. Plywood
4. Paintwork
5. Fabric
6. Metal Fittings and Pins
7. Control Components and Pins
8. Control Cables
9. Lift Struts
10. Quick Releases
11. Skids
12. Wheel, Tyre
13. Pilot's Harness
14. Crash Pad
15. Instruments
16. Transparency of Cockpit Covers

Exhibit G.

What repairs or modifications have been carried out since the issue of the last C. of A.?

.....

.....

REMARKS :—

.....

.....

In addition to the above I certify that :—

- (a) The Flying Controls have been checked for ease of movement, rigidity, wear and correct angular movements in the agreed senses.
- (b) The B.G.A. Number is painted on the Fuselage near the Tailplane.
- (c) The Aircraft has been properly cleaned out after repair.
- (d) Placards giving classification, permitted manœuvres and operating speeds are clearly displayed in the Cockpit.
- (e) Details of empty and maximum all up weight are placarded in the Cockpit or painted on the Fuselage.
- (f) I have examined the Log Book ; it is up to date and contains a record of all repairs and modifications which have been carried out and these have been signed for by an approved person.

I have signed the Log Book. The Log Book shows :—

.....hours }
launches } Total Flying since new.

- (g) According to the Log Book and previous C. of A.

the Glider was weighed on
 (date) which included the equipment given in
 Column 1. (please fill in No. of Items)

Empty Weight was.....lb.
 Empty C. of G. was.....ins. aft/fore of
 datum.

Cross out Either (1) Since then no repairs or
 modifications have been
 carried out which appreci-
 ably affect this.

Or (2) The Glider, after the recent
 repairs or modifications,
 has been re-weighed on
(date) which
 included the equipment
 given in Column 2. (Please
 fill in No. of Items).

Empty Weight was.....lb.
 Empty C. of G. was.....ins.
 aft/fore of datum.

	Col. 1	Col. 2
A.S.I.
Altimeter
T. and Slip
T. and Slip Batteries
Horizon
Horizon Batteries
Vario
Compass
O ₂ Regulator
O ₂ Bottle
Radio
Cushion
Seat Back
Fixed Ballast
Other Equipment

- (h) In my opinion this Glider is airworthy and I recommend that its C. of A. be renewed.
- (i) I enclose previous MCA/BGA (cross out where inapplicable) C. of A. and a renewal Fee of £1 1s. 0d./£2 2s. 0d.
- (j) I have signed the Inspector's Card, Insp./3, and placed it in the Cockpit

Signed..... B.G.A. Insp. No.....
 Address.....

Date.....

Exhibit H.

BRITISH GLIDING ASSOCIATION

B.G.A. FORM No. INSP/1

**This form to be completed by all applicants
for B.G.A. Inspection Approval.**

Name and address
of applicant

Are you over 21 years of age?

Are you a member of a Gliding Club?

If so, which?

Are you at present authorised by your Committee or Chief
Instructor to carry out any inspections?

If so, give details and references

What is your present occupation?

Do you at present hold any A.R.B.
or other licence?

What licence or approval have you
previously held?

Give details of service in Forces if
relevant to this application

Have you ever worked at an Aircraft Factory or Repair Organisation?

If so, with whom and for how long?

Have you any knowledge of wire or rope splicing?

Are you familiar with the British Civil Aviation requirements,
Section E?
or A.P. 2662 A?

Give a short summary of repair work you have already carried out yourself and mention
types of aircraft the repairs were carried out on

The following references are attached 1.
2.

Date : Signed :

Please return the form to :
British Gliding Association,
19 Park Lane, London, W.1.

The fee for approval is £2 2. 0.
Annual renewal ... £1 1. 0.

APPENDIX II.

A LIST OF USEFUL ADDRESSES OF SUPPLIERS

- A.G.S. Parts, etc.
Aircraft Materials Ltd., Midland Road, London, N.W.1.
- Air Publications.
A.D.2662A. "Standard Repairs to Airframes" from the B.G.A.
- B.G.A. 19 Park Lane, London, W.1.
- B.C.A.R. Section E.
Air Registration Board, Chancery House, Chancery Lane, W.C.2.
- Bolts, Nuts, Screws, etc.
Guest Keen & Nettlefolds Ltd., Birmingham, 18.
- Dopes, Paints.
Titanine Ltd., Colindale, London, N.W.9.
Cellon Ltd., Kingston on Thames, Surrey.
Dockers Bros., Ladywood, Birmingham, 16.
- Fabrics for Glider Covering.
A. H. Vane & Co., Empire House, St. Martin le Grand, London,
E.C.1.
- Glider Manufacturers.
Elliot's of Newbury Ltd., Newbury, Berks.
Slingsby Sailplanes Ltd., Kirbymoorside, Yorks.
- Glues.
Messrs. Aero Research, Ltd., Duxford, Cambridge.
- Plywood Glider Manufacturers.
- Quick Releases.
Ottley Motors Ltd., Crescent Works, Crescent Road, Wood Green,
London, N.22.
- Ropes, Nylon, for Aerotowing.
British Ropes Ltd., Leith, Edinburgh, 6.
- Tapes, Masking, Sealing, etc.
Johnson & Johnson Ltd., Slough, Bucks.
- Timber for Repairs.
Glider Manufacturers.



are
you
going
UP in
the
world?

Top people, particularly in the gliding world, know that they move in a rarefied atmosphere and to survive at all they have to take oxygen with them. These people know how to reach the heights in gliding; they also know that the best way to take oxygen is in the British Oxygen Aro A.12 or A.14 diluter demand set. Giving maximum economy and duration, completely automatic operation and greater safety at high altitudes, they are just what one needs to explore that wandering wave or achieve that absolute altitude.

As fitted to OLYMPIA 419 (1958 World Championships)

SKYLARK 3

T.42 EAGLE

1 23

(W. S. Ivans 42220 ft.)

(H. C. N. Goodhart 37000 ft.)

British Oxygen Aro Equipment

THE PINNACLES · HARLOW · ESSEX · HARLOW 26891



INDEX

- A**
- Aerodux**, 9
 - Aerolite**, 9
 - Aerotow**, locking of hooks, 13
 - Aileron horn**, 22
 - A.S.I.**, 24
 - Approved Certificate**, 6
 - Approved Inspector**, 24
 - Approved Materials**, 6
- B**
- Ball races**, 17
 - Bearings**, 17
 - Biscuits**, 12
 - Blooming of dope**, 18
 - Bobbin**, 15
 - Bolts**, 4, 5, 17
 - Booms**, 7
 - Brass tacks**, 12
 - Bushes**, 17
- C**
- Cables**, 2, 15, 24
 - Cable splicing**, 15
 - Canopy**, 20
 - Cantilever**, 21, 22
 - Casein glue**, 2, 8
 - Centre of Gravity**, 7, 24, 26
 - Centre of Pressure**, 21
 - Certificate of Airworthiness**, 23, 27, 29
 - Chamfers**, 10, 12
 - Clamps**, 10
 - Classification of Gliders**, 30
 - Cockpit**, 24, 27
 - Compression shake**, 22, 23
 - Controls**, 15
 - Cotton fabrics**, 18
 - Corrosion**, 1, 2, 5
 - Cracks**, 10, 22
- D**
- Damage**, 22
 - Datum point**, 25
 - Diagonal ply**, 11
 - Diagonals**, 21
 - Dopes**, 6, 18
 - Drag bracing**, 21
 - Drawings**, 7
- E**
- Elevator**, 2
 - Eyesplice**, 15
- F**
- Fabric work**, 19
 - Fabrics**, 2, 18
 - Fairleads**, 15
 - Fatigue**, 13, 15
 - Feather edge**, 10
 - Finishes**, 19, 20
 - Fittings**, 2, 13, 24
 - Flush insertion repair**, 12
 - Forms**, 27
 - Frames**, 21
 - Fungus**, 2, 8
 - Fuselage**, 21
- G**
- Glues**, 8
 - Grain**, 11
 - Grease**, 1
 - Gussets**, 7
- H**
- Hardeners**, 9
 - Heating**, 9
 - Heavy landings**, 21
 - Hinges**, 1, 17
 - Hooks**, release, 1, 13
- I**
- Inspection for damage**, 21
 - Instruments**, 2
 - Internal protection**, 8
- L**
- Lapped joint**, 10, 11
 - Leading edge**, 21, 22
 - Limitations**, 27, 32
 - Links**, 3, 14
 - Locking**, 3, 4
 - Locking wire**, 3
 - Locknuts**, 5
 - Longerons**, 21
 - Looseness**, fittings, 23
 - Lubrication**, 1
- M**
- Madapolam**, 18
 - Max. and Min. Loads**, 25, 27
 - Metal parts**, 13
 - Mixing of glues**, 8, 9
- N**
- Nip**, 17
 - Nuts**, 4, 5



LIGHTWEIGHT OXYGEN EQUIPMENT

NORMALAIR lightweight oxygen equipment was fitted in the sailplane flown by the runner-up in the Open Class at the 1958 World Gliding Championships—Commander N. Goodhart of Great Britain. This pilot also achieved the greatest distance flown along a set line, with a flight of 209 kilometres.

The equipment used is part of a range of items being produced by NORMALAIR for use in light aircraft, small transport aircraft and sailplanes. Both portable sets and fixed installations are in production, component design allowing wide variation of layout to suit individual requirements.

A feature common to all the equipment in this range is very low weight. For example, a fixed installation of 750 litres capacity weighs as little as 12½ lbs. complete. Provision is made in all cases for the selection of different flow rates, the actual rates being variable by adjustment during manufacture. An illustrated catalogue of this equipment is available on request.

NORMALAIR

YEOVIL

ENGLAND

Normalair (Canada) Ltd.
Toronto

Normalair (Australia) Pty. Ltd.
Melbourne

O
Oiling, 1
Oils, 1
Ottfur, 13
Over centre mechanism, 14
Oversize pins, 13

P
Paint, 2, 6
Patches, 10, 19
Perspex, 20
Pickling of dope, 18
Pins, safety, 5
Pins, split, 4, 5
Pins, wing, 5
Placards, cockpit, 26, 27, 30, 31
Plywood, 2, 11
Pressure, clamping, 8, 9
Publications, 27
Pulleys, 1, 17

R
Reaming, 13
Reclamation of fittings, 13
Release Note, 6
Reinforcing strip, 11
Renewal of C. of A., 23
Repairs, 6, 9, 10, 11, 13
Requirements, 29
Ribs, 10, 18
Rigidity, 6
Rust, 1

S
Safety, turnbuckles, 3
Sanding, 8
Scarfs, ply, 11
Scarfs, timber, 10
Shear, 8
Skids, 13
Spar, 7, 21
Splices, 6, 10
Splicing cable, 15
Spruce, 10
Steel, mild, 13
Steel, high tensile, 13
Strength of glue, 9
Struts, 21
Swaged end splice, 3, 15

T
Tack strip, 12
Tacks, 12
Tailplane, 21
Testing of materials, 6
Tension, glue in, 8
Tension of cables, 2

Thimble, 15
Thinners anti chill, 18
Threads in bearing, 5
Threads in shear, 5
Timber, 2, 9
Turnbuckles, 3
Types of glider, 21
Tyres, 24

U
Ultra violet light, 2, 18

W
Washers, 4, 5
Wear, 14, 24
Weighing, 25
Weights, 24, 25
Welding, 13
Wheels, 24
Whipping of splices, 16
Wire, drag, 21
Wire, locking, 3

Y
Year of construction, 29

THE B.G.A. AIRWORTHINESS SCHEME

by C. O. Vernon

SAFETY in flight, and in this connection flight includes launching and landing, depends on three factors only—the airworthiness of the glider, the method of operation of the glider, and the pilotage. That the latter must be sufficiently skilful and accurate is obvious enough; the operational factor is looked after by the B.G.A. Operational Regulations. In this chapter we are concerned with the airworthiness of the glider.

The procedure adopted by the B.G.A., as by all other airworthiness bodies, is to require that certain standards of design (including structural strength, stiffness and flying qualities) and construction are met; when satisfactory evidence of the achievement of these standards is received, a Certificate of Airworthiness, or a renewal thereof, is issued in respect of each and every glider. Much more evidence is required in the case of a new prototype than for a series aircraft or for a renewal.

A Certificate of Airworthiness, or C. of A., can be obtained either from the B.G.A., or from the Ministry of Transport and Civil Aviation (M.T.C.A.) in conjunction with the Air Registration Board (ARB).

This applies whether the glider is designed and built by a firm or privately, save that B.G.A.'s C. of A. cannot be issued for gliders of more than 1,250 lbs. all up weight. The B.G.A. C. of A. document is described in Appendix I and illustrated in Exhibit A. A C. of A. automatically becomes invalid if its period of validity (usually one year) expires, if the glider is damaged such that in the opinion of an Approved Inspector it is no longer airworthy, or if unauthorised modifications (other than minor ones) are made.

At the present time, it is not a legal requirement that gliders must have C's. of A. unless they are to be used for public transport or aerial work. It is, however, necessary that third-party insurance, by an authorised insurer and for an amount of liability of not less than £3,000, is in force. It is also a B.G.A. Operational Regulation that a glider may be flown at the site of a B.G.A. member club only if it has a valid C. of A. (either M.T.C.A. or B.G.A.) or equivalent Service document.

Certificate of Airworthiness Renewal

The procedure for a C. of A. renewal is described in detail from the practical point of view in Chapter 8, and is hence considered only briefly here; it is broadly as follows.

The glider is examined by an Approved Inspector who decides the extent of the overhaul necessary to ensure that it will remain airworthy for another twelve months, subject to adequate maintenance being provided and to any damage being made good.

When the overhaul is completed satisfactorily, the inspector sends the necessary documents to the B.G.A., who then re-validate the C. of A. for a period of one year from the date of the inspection.

Certificate of Airworthiness for New Type Glider

As indicated above, the procedure for obtaining a C. of A. for a new prototype is much more extensive, and involves certain checks of the design and construction of the glider, which must be to the current issue of B.C.A.R. Section E, except as otherwise notified or agreed by the B.G.A. The procedure differs in some respects according to whether the glider is designed and constructed privately or by an approved manufacturer. An approved manufacturer is one having design and inspection organisations approved by the B.G.A., for the purpose of which approval, the B.G.A. adopts as requirements, the relevant A.R.B. requirements, only. B.C.A.R. Chapters A 7-1 and A 7-5. A manufacturer approved by the B.G.A. is generally approved by the A.R.B. also.

To make the actual procedure easier to follow, some of the terms used are first defined.

First, the Type Record. This is a document prepared by the designer as a summary of the design, comprising:

- (a) The Certificate of Design, i.e. a certificate in the form shown (SEE OVER) and signed by the designer.
- (b) A three-view G.A. (General Arrangement) drawing.

CERTIFICATION OF DESIGN

Pro-forma for Certification of Design

Aircraft Type Category.....

Constructors' Serial No..... B.G.A. Serial No.....

I certify that, with the exceptions stated below, the above aircraft is of a design which complies with B.C.A.R. Section E. dated..... and the additional requirements which have been notified in writing by the B.G.A. as applying to this aircraft and which are listed or referred to below.

Exceptions Additional Requirements.....

.....
.....

(Signed)

(Firm)

Date (Address)

.....

(c) A list of component G.A. drawings and issue numbers.

(d) A summary of design assumptions, i.e. a statement of the leading dimensions and principal aerodynamics and weight data upon which the design calculations are based. As a minimum it must include wing and tail unit geometry, all up weight and C.G. positions, moments of inertia, weight breakdown assumed in strength calculations, design speeds (stall, dive, etc.), lift and drag estimates, pitching movement of wing and fuselage, downwash at tail-plane, and spanwise lift, distribution of wing.

(e) A strength and stiffness summary, i.e. a statement of design loads, critical cases, reserve factors achieved and stiffnesses achieved, for all primary structure components, including references to design criteria and assumptions on which the calculations are based.

(f) The weighed weight and C.G. position and the loading data (maximum and minimum cockpit loads) determined therefrom.

(g) References to strength, stiffness, and other pre-flight test reports, or the

reports themselves, or the test results, as appropriate. The tests required are stated in the Design Requirements, i.e. in B.C.A.R. Section E.

(h) References to Flight Test Reports or the reports themselves. Again, the tests required are given in B.C.A.R. Section E.

Secondly, the Design Survey. This is an examination of the design by the B.G.A. to check as far as possible that the Design Requirements are complied with, particularly those requirements which are expressed in qualitative terms, e.g. those in the Design and Construction chapters of B.C.A.R. Section E. The Survey is carried out by a Design Surveyor appointed by the B.G.A. when each occasion arises, and who is usually a member of the Technical Committee. The designer may wish to consult the Surveyor in the interpretation of the requirements concerned.

Thirdly, the Engineering Assessment. This is an appraisal of the glider by the B.G.A. at a suitable stage of construction at or near completion (but before covering). The appraisal embraces all engineering aspects of the glider not covered by the Design Survey, and is intended to ensure as far as possible that the glider will be able to be operated satisfactorily and maintained

in an airworthy condition without undue difficulty by the operators, be they clubs or private owners, for whom it is intended. The assessment is made by an Engineering Assessor who, again, is appointed by the B.G.A. as each occasion arises.

The Design Survey and Engineering Assessment are, theoretically, distinct; in practice they may overlap to some extent.

The C. of A. procedure itself can now be described. The general procedure is defined first, and this is followed by the particular procedures for approved manufacturers and private constructors respectively, which, as noted above, differ somewhat.

In general terms, then, the steps to be taken are as follows.

1. The design of the glider is summarised in the Type Record.
2. The Design Survey is carried out; this may be in several stages.
3. The Engineering Assessment is carried out.
4. The completed glider is inspected by an Approved Inspector.
5. The completed glider is weighed and its Centre of Gravity determined.
6. Pre-flight tests are carried out.
7. Subject to (1), (4), (5) and (6) being satisfactory, the glider is test flown under the authority of a Permit to Fly issued by the B.G.A.
8. The Type Record, including the results of the weighing and the pre-flight tests, and the Flight Test Reports if not also included are submitted to the B.G.A., accompanied by an application form and the prescribed fee. They are studied together with the Design Survey and Engineering Assessment, and when they are all approved the type C. of A. is issued.

In the case of approved manufacturers, the glider may be flown under the authority of their approval alone, after a satisfactory inspection by the firm's inspection department and satisfactory completion of pre-flight tests and weighing, i.e., before the Design Survey and Engineering Assessment are made. In fact the glider may, in the absence of unorthodox features, be designed, constructed, and test flown without any reference whatever being made to the B.G.A. It is, however, to be recommended that the Survey and Assessment are made, at least partially, at a suitable stage before testing is begun, as this might avoid or

reduce subsequent delay in the granting of a C. of A. pending the rectification of some unacceptable feature. The Type Record need not be formally completed before the glider is flown, though the data from which it is compiled will normally be available, except of course for flight test reports.

In the case of private constructors, on the other hand, the Design Survey, Engineering Assessment and an inspection by a B.G.A. Approved Inspector must be made, and a partial Type Record compiled, before the glider is flown. When satisfied with these, the B.G.A. issues a Permit to Fly, whereupon flight tests may be carried out either by a B.G.A. Flight Test Group or by an individual approved for each specific case. In more detail, the procedure for obtaining the Permit to Fly is as follows:—

- (i) The design surveyor makes his survey and accepts the partial Type Record, which must contain the results of the weighing and of the pre-flight tests, and reports to the B.G.A.
- (ii) The Engineering Assessor makes his assessment and reports to the B.G.A., either directly or, if appropriate, through the Design Surveyor.
- (iii) Subject to the partial Type Record, Design, Survey and Engineering Assessment being satisfactory, the B.G.A. issues the Permit to Fly, which specified the Test Group or individual pilot as necessary.
- (iv) The Approved Inspector who has supervised the construction of the glider, gives the final approval after clearing the glider for flight.

From this point onwards, the procedure is similar for both approved manufacturers and private constructors. When the flight tests are concluded, the Type Record is completed and submitted, together with the Flight Test Reports (if not included therein) to the B.G.A. The latter then considers all the relevant reports and information, and, if satisfied, decides upon the various limitations and issues the C. of A. accordingly. In the event of any features being found to be unacceptable, the C. of A. will be conditional upon these being rectified, and if those features concern handling the C. of A. will normally be withheld until further flight tests are done.

The above procedures and the records or

reports which must be furnished before flight testing may begin and before the

C. of A. can be issued, are summarised in the table (below).

Summary of procedure for type C. of A.

	Approved Manufacturers		Private Constructors	
	Flight Test	C. of A.	Permit to Fly	C. of A.
Type Record	No	Yes	Yes***	Yes
Design Survey	*	Yes	Yes	—
Engineering Assessment	*	Yes	Yes	—
Inspection (by B.G.A.)	No	Yes	Yes	—
Weighing	Yes**	Yes	Yes	—
Pre-flight Tests	Yes**	Yes	Yes	—
Test Flights	—	Yes	—	Yes
Test Flight Reports	—	Yes	—	Yes

* Desirable but not essential.

** Reports need not be submitted at this stage.

*** Partial only at this stage.

Modifications

For the purpose of this book, modifications may be considered to be of two kinds:

1. Those essential for safety, initiated by the manufacturer or by the B.G.A.
2. Those initiated by the owner or operator to improve performance or convenience or handling, and which may also affect safety.

As regards the first kind, all that need be said here is that instructions for their embodiment including in each case a statement of the urgency thereof are issued by the manufacturer or by the B.G.A. It is in the second kind that we are more interested.

The B.G.A. is concerned with this second kind, where safety is involved, but not otherwise. Any modification which affects safety automatically invalidates the C. of A. unless authorised by the B.G.A. In this connection, safety means all factors embraced within the heading of airworthiness, including structural strength and stiffness, cockpit design, and flying characteristics. In other words, a modification which changes any of these requires B.G.A. approval, and it is therefore essential to consider, before any modifica-

tion is made, whether one or more of these qualities may be affected. If they are, the approval for such modifications must be sought.

Examples of such modifications are:

- (i) Those which alter the external shape, such as changes to windscreens or rudder horn balances, or the fitting of dorsal fins or airbrakes where more existed before.
- (ii) Bungee trimmers or any kind of mass attached to control surfaces or control circuits.
- (iii) Any installation involving cutting or piercing of primary or secondary structure, such as fitting a landing wheel where none existed before. Fitting of airbrakes may come into this category also.
- (iv) Any installation involving increases in the loads to which the glider is subjected, such as the fitting of a belly-hook where none existed before.

Approval for modifications is given by the B.G.A. in conjunction with the manufacturers of the glider where appropriate, after it is satisfied that the modification is airworthy. To enable the B.G.A. to decide this, the application, which should be in writing, should be accompanied by a

description of the proposed modification, suitable drawings or sketches, and strength figures, or references to a manufacturer's approved drawings. As in the case of type C's. of A., the B.G.A. may require amendments or flight tests before granting approval.

In considering all this, a sense of proportion should of course be maintained. Purely minor modifications such as re-arrangement of instrument panel layout (provided that clearances are not adversely affected) or *small* local external protuberances or fairings do not need special approval. Difficulty may, however, arise in deciding what is minor or what is small; in cases of doubt the B.G.A. should be consulted.

Log Books

The log-book is the gliders' biography, and its proper keeping is an essential part of the Airworthiness Scheme. It should contain a record of the aircraft's operations and of the repairs, maintenance and modifications.

As regards operations, no great detail is necessary. An entry at suitable periods, e.g. monthly, of the number of launches and hours flown is all that is strictly necessary. It may be helpful also to note such things as heavy landings even though no immediate damage is evident; they may have "started" something that may get worse in subsequent bumps. If this does occur, it is essential that

it is found at the next C. of A. inspection, and the presence of such entries in the log book will lead the inspector to examine all the more thoroughly.

Repairs and maintenance form the most important entries, whether concerned with the C. of A. renewal or otherwise. It is essential to state just what has been done, and where it has been done, the entry should be sufficiently detailed to make this quite clear. For example, in the case of a rib boom repair, the site number, whether top or bottom boom, and whether in front of or behind the spar(s) should be stated. If a spar is repaired, the members affected (top boom, rear web, etc.) and the spanwise location should be given.

Minor repairs should also be mentioned; while in the case of several re-glued gussets, for example, the exact location of every one is not vital, at least the number and approximate position should be given. Quite simple maintenance items such as re-greasing of hinge pins or re-adjustment of control circuits should be recorded when the flying characteristics are likely to be affected.

In the case of modifications, a brief descriptive statement, together with a reference to a modification and/or drawing number, is all that is required in the case of a manufacturer's or B.G.A. modification, a suitable drawing is sufficient, but not necessarily full detail, should be attached to the log book.

B.G.A. Airworthiness Fees

C's of A. for Manufacturers prototype gliders	£5 5s. 0d.
C's of A. for Privately designed and constructed gliders ..	By arrangement
C's of A. for Manufacturers production gliders	£2 2s. 0d.
C's of A. for other gliders	£2 2s. 0d.
C's of A. for Foreign gliders	By arrangement

Renewals

B.G.A. Members	£1 1s. 0d.
Non-members	£2 2s. 0d.
Fee for Inspector's Approval	£2 2s. 0d.
Annual renewal	£1 1s. 0d.

