

# THE GLIDING FEDERATION OF AUSTRALIA



## POWERED SAILPLANES

**A manual for pilots converting to powered sailplanes from gliders, ultralights  
and general-aviation light aircraft**

<b>INTRODUCTION</b>	<b>5</b>
<b>GLOSSARY OF TERMS AND ABBREVIATIONS USED IN THIS MANUAL</b>	<b>6</b>
<b>1. DEFINITIONS (FROM CAO 95.4)</b>	<b>7</b>
1.1. POWERED SAILPLANE	7
1.2. POWER-ASSISTED SAILPLANE	7
1.3. PLACARDS	7
<b>2. POWERED SAILPLANE VARIETIES</b>	<b>8</b>
2.1. Front-engine, fixed pitch propeller	8
2.2. Front engine, variable pitch feathering propeller	9
2.3. Retractable engine and propeller	10
2.4. Fixed engine, retractable propeller	12
2.5. Non-retractable engine on a stalk	13
2.6. Rear-mounted engine, folding propeller blades	14
2.7. "TOP" conversions	14
2.8. Jet powered	14
<b>3. DAILY INSPECTION AND PRE-FLIGHT CHECK</b>	<b>15</b>
3.1. INTRODUCTION	15
3.1.1. The engine	15
3.1.2. The propeller	15
3.1.3. The fuel system	15
3.1.4. The electrical system	16
<b>4. POWERED SAILPLANE CHARACTERISTICS</b>	<b>17</b>
4.1. THE EFFECT OF UNDERCARRIAGE DESIGN ON HANDLING	17
4.1.1. Glider-type undercarriage	17
4.1.2. Aircraft-type undercarriage	17
4.1.3. "Nosedragger" design	17
4.1.4. "Tailedragger" design	18
4.1.5. Ground-handling and taxiing techniques	19
4.2. THE EFFECT OF THE ENGINE ON HANDLING	19
4.2.1. The effect of the engine on aircraft trim	19
4.2.2. The effect of the engine on directional control on take-off	20
4.2.3. The effect of the engine in the climb	21
4.3. ENGINE, FUEL SYSTEM AND PROPELLER MANAGEMENT	22
4.3.1. Engine management	22
4.3.2. Engine shut-down - all types	24
4.3.3. Induction icing	24
4.3.4. Density altitude	26
4.3.5. Soft ground	27

4.3.6. Tug-assisted launches	27
4.3.7. Fuel management	27
4.3.8. Propeller management	28
4.3.9. Engine starting in flight	30
4.3.10. Mixture control	31
4.3.11. Powered sailplane landing characteristics	32
4.3.12. Landing with engine extended but stopped	33
<b>5. TRAINING AND CONVERSION REQUIREMENTS</b>	<b>34</b>
<b>5.1. ALL-THROUGH TRAINING IN POWERED SAILPLANES</b>	<b>34</b>
5.1.1. General	34
5.1.2. Syllabus of basic powered sailplane training	34
<b>5.2. CONVERSION FROM GLIDERS TO POWERED SAILPLANES</b>	<b>35</b>
<b>5.3. CONVERSION FROM POWERED AIRCRAFT AND ULTRALIGHTS TO POWERED SAILPLANES</b>	<b>35</b>
<b>6. BASIC NAVIGATION</b>	<b>36</b>
<b>6.1. GENERAL</b>	<b>36</b>
<b>6.2. MAPS, CHARTS AND OTHER ESSENTIAL DOCUMENTS</b>	<b>36</b>
6.2.1. The World Aeronautical Chart	36
6.2.2. En-Route Chart, Low (ERC Low)	36
6.2.3. Visual Terminal Chart (VTC)	36
<b>6.3. TRACK, DRIFT, HEADING</b>	<b>37</b>
6.3.1. Track	37
6.3.2. Drift	37
6.3.3. Heading	37
<b>6.4. AIRSPEED AND GROUND SPEED</b>	<b>37</b>
<b>6.5. THE TRIANGLE OF VELOCITIES</b>	<b>38</b>
<b>6.6. CORRECTING FOR DRIFT</b>	<b>39</b>
<b>6.7. USE OF THE COMPASS</b>	<b>39</b>
<b>6.8. WHAT IF YOU GET LOST?</b>	<b>40</b>
<b>USEFUL TIPS TO PREVENT GETTING LOST</b>	<b>40</b>
<b>7. HAZARDOUS WEATHER</b>	<b>41</b>
<b>7.1. GENERAL</b>	<b>41</b>
<b>7.2. OROGRAPHIC CLOUD</b>	<b>41</b>
<b>7.3. FOG</b>	<b>43</b>
7.3.1. Radiation fog	43
7.3.2. Advection fog	43
<b>7.4. THUNDERSTORMS</b>	<b>43</b>

<b>8.1. UNLANDABLE TERRAIN</b>	<b>46</b>
<b>8.2. INSUFFICIENT TERRAIN CLEARANCE</b>	<b>46</b>
<b>8.3. INTENTIONAL LOW FLYING</b>	<b>46</b>
<b>9. INSTRUCTING IN POWERED SAILPLANES</b>	<b>47</b>
<b>9.1. TAKEOFF EMERGENCIES</b>	<b>47</b>
9.1.1. Aborted take off	47
9.1.2. Engine failure during climb out	47
<b>9.2. ENGINE OFF PERFORMANCE</b>	<b>48</b>
<b>9.3. CIRCUITS, APPROACHES AND LANDINGS</b>	<b>48</b>
9.3.1. Engine-off circuits and landings	48
9.3.2. Joining the circuit in exactly the same way as a glider does	49
9.3.3. Touch and go landings	49
<b>9.4. CROSS-COUNTRY AND OUTLANDING TRAINING</b>	<b>50</b>
<b>9.5. SIMULATED LAUNCH EMERGENCIES</b>	<b>50</b>
<b>9.6. PARTICULAR TIPS FOR CONVERTING POWER PILOTS TO POWERED SAILPLANES</b>	<b>51</b>
9.6.1. Use of lift and sink.	51
9.6.2. Use of spoilers/airbrakes.	51
9.6.3. Use of aiming point.	51
9.6.4. Coordinating between elevator and spoiler/airbrake.	52
9.6.5. Throttle creeping open.	52
<b>10. POWER-ASSISTED SAILPLANES</b>	<b>53</b>
<b>11. TOWING GLIDERS WITH POWERED SAILPLANES</b>	<b>54</b>

## POWERED SAILPLANES

### INTRODUCTION

Some gliders have a built-in engine to enable them to self-launch. This enables them to operate independently of conventional club launching equipment and, provided the engine starts readily in flight, to render trailer-retrieving obsolete.

These machines are known in Australia as “powered sailplanes”. They come in all shapes and sizes. Some are conversions of existing sailplane designs, with an engine (usually retractable) added to them. Others are designed from the start as powered sailplanes and some of them have the appearance of long-winged light aircraft. All of them make demands on their pilots which are somewhat different from those placed on pilots of either gliders or light aircraft.

Relatively few of the engines fitted to powered sailplanes are aero-engines. Many of them are two-strokes and even some of the four-stroke engines are not certificated as aircraft engines. This means that their reliability may not be quite the same as fully-certificated engines and this affects the training of pilots of these machines.

There is another breed of glider fitted with an engine. This is the so-called “power-assisted sailplane”, known in some quarters as a “turbo” sailplane. The engine fitted to these machines are not powerful enough to self-launch and are intended only to prevent an outlanding by providing a self-retrieve facility. To this end, power-assisted sailplanes are not usually fitted with any engine-management systems and don't even have a throttle. They are generally not able to be started on the ground, but must make use of the windmilling effect of the airflow in flight to spin the engine to get it started.

This handbook covers the characteristics of all varieties of powered sailplanes and power-assisted sailplanes, together with the conversion requirements and training syllabi for pilots coming to them from gliders or powered aircraft.

Published by :-

Gliding Federation of Australia,  
130 Wirraway Road,  
Essendon Airport, Vic 3041.  
Tel: (03) 9379 7411,  
Fax: (03) 9378 5519,  
E-mail: Doo@GFA.org.au

© Gliding Federation of Australia, 1998

## GLOSSARY OF TERMS AND ABBREVIATIONS USED IN THIS MANUAL

AA	Airservices Australia
AGL	Above Ground Level
AMSL	Above Mean Sea Level
AUF	Australian Ultralight Federation
BASI	Bureau of Air Safety Investigation
CAO	Civil Aviation Order
CAR	Civil Aviations Regulation
CASA	Civil Aviation Safety Authority
CG	Centre of Gravity
CTAF	Common Traffic Advisory Frequency
ERC(L)	En-Route Chart (Low)
FAI	Fédération Aéronautique Internationale, the international governing body for sport and recreational aviation
GA	General Aviation, which includes all VH-registered light aircraft and small charter and RPT aircraft
GFA	The Gliding Federation of Australia
GNSS	Global Navigation Satellite System
GPS	Global Positioning System, the alternative name for GNSS
ICAO	International Civil Aviation Organisation, the aviation arm of the United Nations
IFR	Instrument Flight Rules
ISA	International Standard Atmosphere (an agreed standard for an "average" atmosphere, based on an air temperature of 15°, a pressure of 1013.25 hPa and a fixed lapse rate of temperature and pressure)
JAR	Joint Airworthiness Requirements (European)
JAR22	Joint Airworthiness Requirements, Section 22 (Gliders, Powered Sailplanes and Power-assisted Sailplanes)
MBZ	Mandatory Broadcast Zone
NM	Nautical Mile, the standard measurement for airborne distances
PAS	Power-assisted sailplane
PPL	Private Pilot's Licence
PS	Powered sailplane
RPM	Revolutions per minute
RPT	Regular Public Transport, airline operations to a published timetable
VFR	Visual Flight Rules
VTC	Visual Terminal Chart
WAC	World Aeronautical Chart, the standard map used for VFR flights

## 1. DEFINITIONS (FROM CAO 95.4)

### 1.1. POWERED SAILPLANE

1. The ratio of the maximum mass (W) in kilograms to the square of the wingspan (b) in metres must not exceed 3kg/sq. metre. (i.e.  $W/b^2 = 3\text{kg/m}^2$  max).
2. The minimum climb rate is 300 metres in 4 minutes.
3. The minimum sink rate must not exceed :-
  - (i) 1 metre per second for single-seaters, or
  - (ii) 1.2 metres per second for two-seaters
4. The minimum glide-slope at maximum landing mass with spoilers/airbrakes fully extended must not exceed one in seven (1:7) at 1.3 V<sub>so</sub> (stall speed in landing configuration).
5. The maximum number of seats is two.

### 1.2. POWER-ASSISTED SAILPLANE

This is an aircraft meeting glider certification standards, fitted with auxiliary power NOT SUFFICIENT to meet the take-off requirement specified for a powered sailplane and capable of only limited duration powered flight. The rate of climb of a power-assisted sailplane at the manufacturer's maximum take-off weight under ISA\* conditions at sea level, shall not exceed 1 metre per second.

\*ISA = International Standard Atmosphere, which is a pressure of 1013.2 hectopascals, a temperature of +15°C and a density of .076 lbs/cu.ft.

### 1.3. PLACARDS

A powered sailplane shall carry an engraved placard as follows :-

**THIS POWERED SAILPLANE MUST BE OPERATED IN ACCORDANCE WITH  
THE PROVISIONS OF CAO 95.4 AND THE GFA OPERATIONAL  
REGULATIONS**

A power-assisted sailplane shall carry a similar engraved placard, substituting the words "power-assisted sailplane" for "powered sailplane" and in addition shall carry the following engraved placard :-

**TAKE-OFFS USING ONLY INSTALLED ENGINE POWER ARE PROHIBITED**

## 2. POWERED SAILPLANE VARIETIES

### 2.1. Front-engine, fixed pitch propeller

These aircraft are usually designed from scratch as powered sailplanes and most of them resemble a long-winged powered aircraft on a glider undercarriage, with outriggers to enable them to be taxied.

A common engine for aircraft of this type is one of the derivatives of the Volkswagen basic design. For fixed-pitch propeller applications, these engines range from the 1200cc Stamo engine to the 1500 and 1600cc Rectimo and Limbach versions. This gives a range of maximum power from 34 kilowatts (45 h.p.) to 51 kilowatts (68 h.p.).

The advantage of a fixed pitch propeller is simplicity, both of installation and operation. The disadvantages are inability to produce full power at typical take-off and climb speed (unless a fine pitch prop is fitted, which then tends to result in over-revving in engine-on cruising flight) and very high drag when the engine is stopped for gliding flight (because the blades cannot be aligned with the airflow and they act as quite effective airbrakes).

A typical front-engine, fixed pitch powered sailplane (Scheibe Falke) is illustrated below. Note the outriggers to balance the aircraft while taxiing.

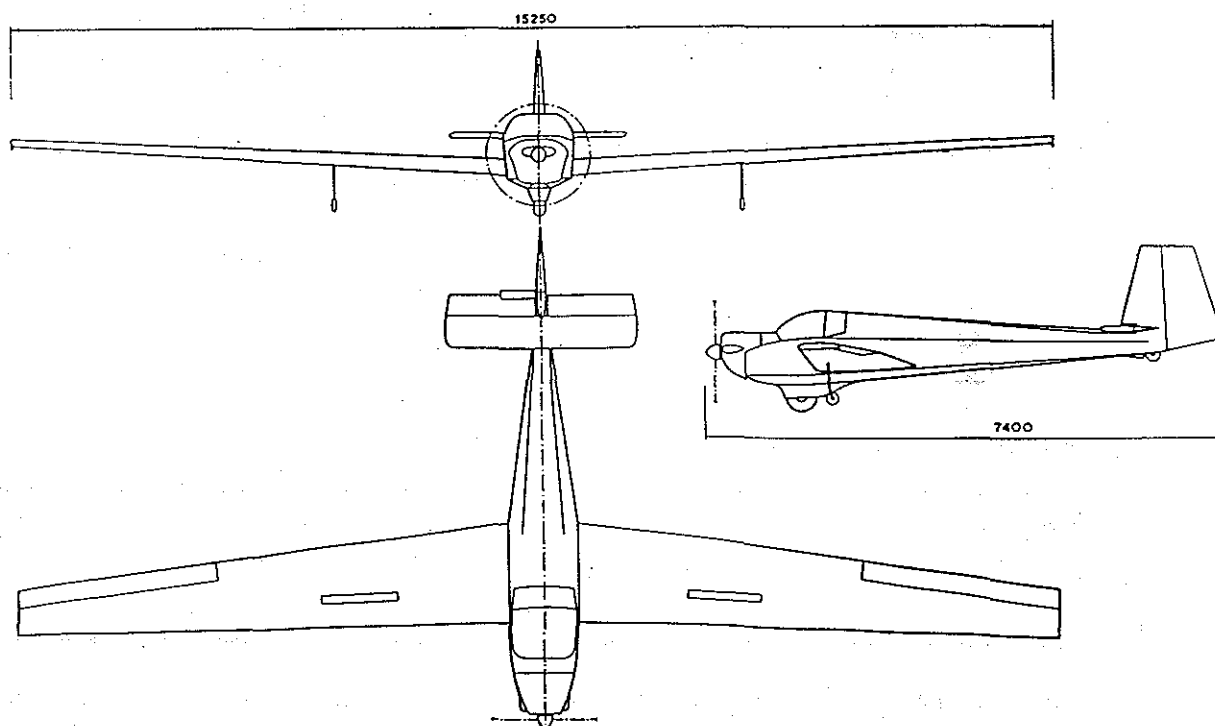

Wingspan: 15.25 m. Wing area: 17.5 m<sup>2</sup>. All-up weight: 610 kgs. Wing loading: 30 kg/m<sup>2</sup>. Engine off min. sink: 0.95 m/s. Max L/D 20:1.  $W/b^2 = 2.6$ .



Despite falling well within the  $W/b^2$  definition, the Falke is a rather poor glider by modern standards because of its old-fashioned aerofoil section (Mü) and the considerable drag of the engine and propeller out front. The weight of the engine, propeller, fuel tank and associated systems is also dead weight in gliding flight (as it is in all powered sailplanes). Together with the drag of the stationary propeller, it is little wonder that the gliding performance is poor.

The Falke is a poor powered aircraft because of the low power-to-weight ratio. The basic climb rate is rather low and the lowest-powered variants have no tolerance to sinking air. The type is demanding to fly in hot conditions and this explains why many owners of the 45 h.p. version of these machines have upgraded them to at least 68 h.p.

Nevertheless, in spite of their limitations, these low-performance powered sailplanes have a rôle to play in gliding clubs. They train glider pilots from scratch quite well, because they have a glider-type undercarriage, use glider speeds and handle like gliders. They are excellent for outlanding training, as their side-by-side seating makes it much easier to identify specific paddocks and eliminate confusion when setting up a circuit into the selected paddock.

## **2.2. Front engine, variable pitch feathering propeller**

This opens up a wider variety of types. As well as a variable-pitch, feathering version of the Falke, other types in this category include the Fournier RF5B Sperber, Grob G109, Vivat, Dimona and Super Ximango. The Sperber, G109 and Dimona use developed versions of the VW engine, the Vivat uses an Aerotechnic Mikron aero-engine and the Super Ximango uses the Rotax 912, a relatively new aero-engine design which is proving its worth in a wide variety of aircraft types.

Being able to vary the pitch makes a considerable difference to the climb performance, as well as the engine-on performance in cruising flight, because the pilot can vary the RPM to extract the optimum power from the engine.

However, the most important feature for the glider pilot is to be able to “feather” the propeller. Feathering is simply the process of aligning a stationary propeller with the airflow. A stationary fixed-pitch propeller presents a very flat aspect of its blades to the airflow and it needs little imagination to realise that this produces a lot of drag. If the facility is provided to adjust the angle of the blades to the extent that they are aligned with the airflow, much of the propeller drag can be eliminated. This is exactly what a feathering propeller does. Although such devices are common on multi-engined aircraft, powered sailplanes are probably the only single-engined aircraft on which they will be found.

Many of the front-engine feathering powered sailplanes have strayed away from their original glider heritage (if they ever had any to start with). Undercarriages tend to be “taildragger” powered aircraft type, they have hydraulic toe-operated differential brakes and their operating speeds, especially in thermalling, are too high to be credible for teaching glider pilots. Handling, too, lacks the feel and sensitivity of gliders. Some powered sailplanes in this category also lack dual airbrake controls, making them a poor proposition for the basic training of glider pilots and necessitating extreme care in conversion flying.

The advantages of a feathering propeller have already been covered. The main disadvantages are complication and cost. However, the common Hoffman feathering propeller is well-proven and gives little trouble in service.

If you have a front-engined powered sailplane, you really do need a feathering propeller. Illustrated below is a Grob G109.

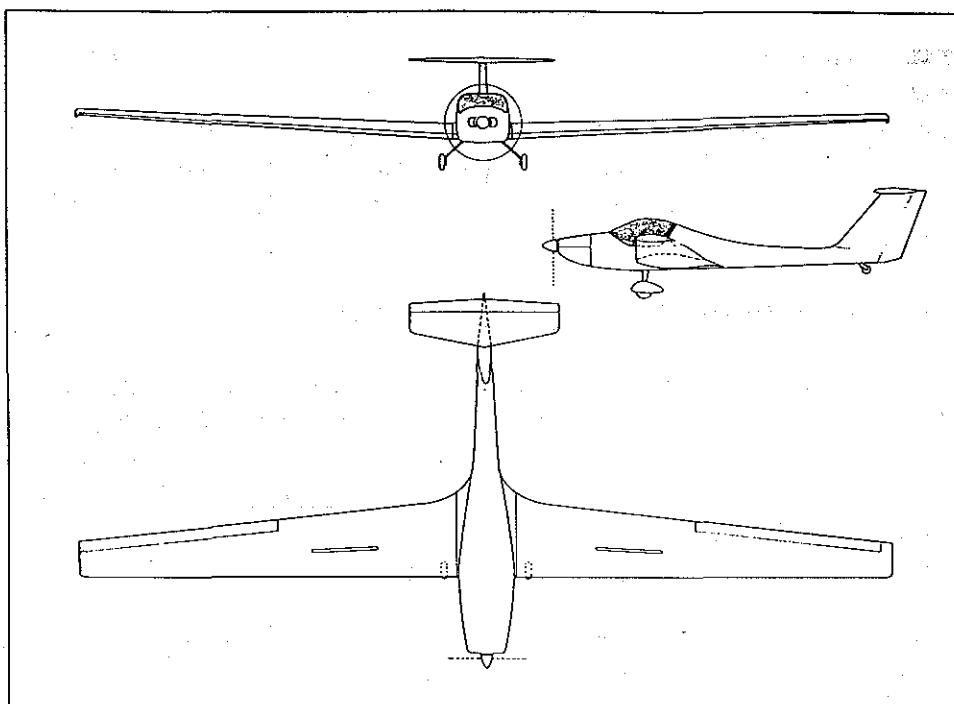

Wingspan 16.6 metres, wing area 20.4 m<sup>2</sup>

Max L/D 30:1, Engine-off minimum sink rate 1.14 m/s

Max all-up weight 825 kgs, Wing loading 40.4 kg/m<sup>2</sup>

$W/b^2 = 3$  (actually 2.993 - it only just makes it into the definition)

### 2.3. Retractable engine and propeller

Powered sailplanes in this category used to be mostly manufacturers' conversions of existing sailplane designs, but there is an increasing tendency towards designing gliders from scratch to incorporate a pop-up engine.

There are single-seaters and two-seaters in this category. They all have their engines mounted in a bay behind the cockpit and extending upwards and forwards. When the engine and prop are retracted, the engine bay is closed by flush-fitting doors to retain the smooth lines of the fuselage and keep drag to a minimum.

The example shown below is the Glaser-Dirks DG400 single-seater. The doors that enclose the retracted engine are visible. The tailwheel is steerable via the rudder pedals, but the absence of outriggers makes taxiing awkward if there is long grass or obstacles around. Note the option to extend the wingspan to 17 metres, useful to keep the wing-loading down in a machine which has a basically high empty weight.

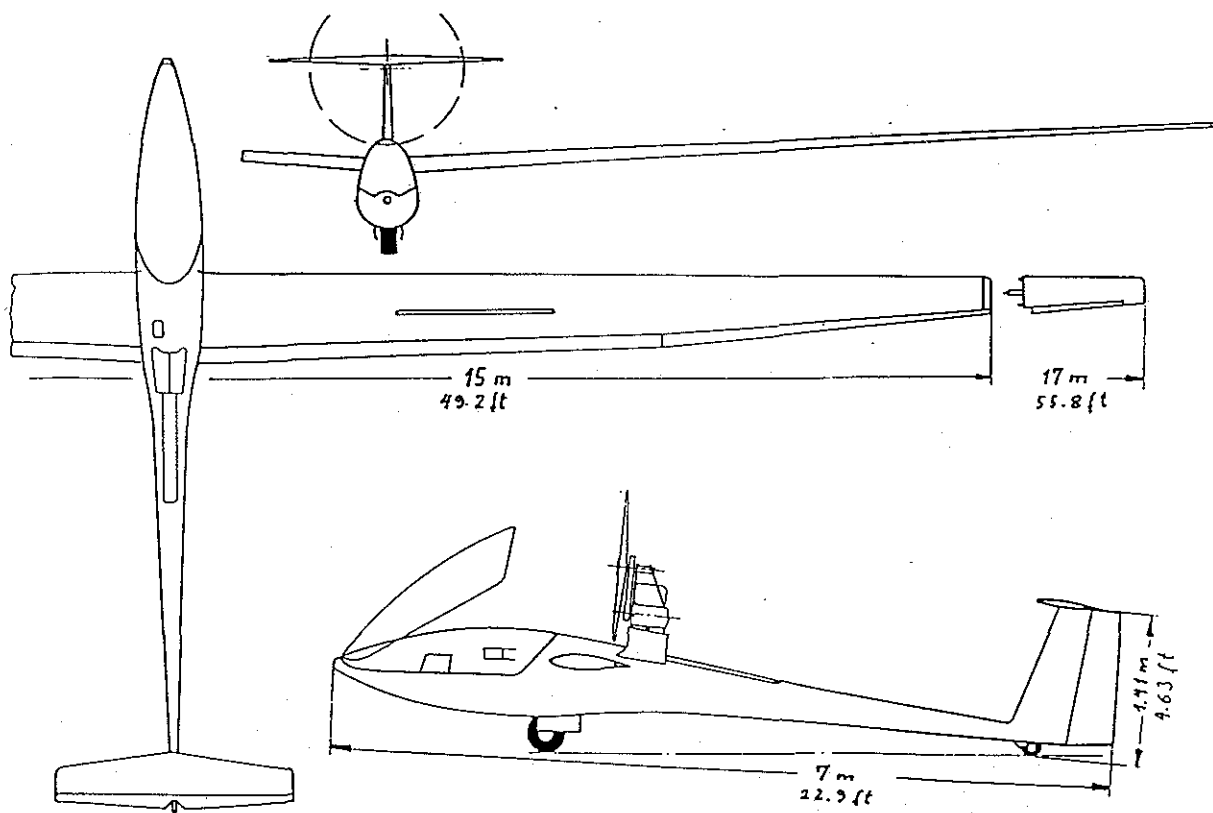

Wingspan 15 metres, optional 17 metres. Maximum all-up weight 480 kgs (15 m), 460 kgs (17 m). Minimum sink rate (15 m) 0.6 m/s, (17 m) 0.54 m/s. Max L/D (15 m) 42:1, (17 m) 45:1.  $W/b^2$  (15 m) = 2.1, (17 m) = 1.6.

These types vary greatly in their individual systems and characteristics. Some have manual extension and retraction mechanisms, via cables and a crank in the cockpit. Others have an electrical system to do the same job. We don't want too many cranks in the cockpit, do we?

The biggest problem with this category of powered sailplane is the engine failure case. If the engine is extended, but not running, the drag is enormous and the performance of the glider suffers horribly. We are not speaking of a 10% or 15% reduction in performance here, but well over 100% in some cases. The DG400 degrades from 40:1 clean to 13:1 with the engine extended but not running.

#### 2.4. Fixed engine, retractable propeller

A variation on the retractable theme is to have a fixed engine installation in the fuselage with the propeller extending and retracting. This saves some drag and results in a much quieter aircraft from outside. Even so, the drag is still considerable. The Nimbus 4DM, arguably the highest-performance powered sailplane in the world and equipped with a fixed engine and retractable propeller, has a glide-ratio approaching 60:1 with the propeller retracted and all the doors closed.

With the propeller extended and the engine not running, it is a different matter. The sailplane's flight manual carries the following warning :-

#### WARNING

With propeller fully extended, the rate of descent increases to a value of about 2.25 m/s (443 ft/min or about 4½ knots) at a speed of 105 km/hr (57 knots) and the L/D deteriorates to about 15:1 - therefore be cautious when using the airbrakes!

The exclamation mark is the manufacturer's.

The difference between the engine/propeller-retracted and engine/propeller-extended glide performance is a very nasty surprise if the pilot is not ready for it. The three cases likely to trap pilots into having an accident are:

- (i) Engine failure just after take-off, the poor engine-off performance giving very little time to ensure a safe landing. If the engine fails at 200 feet, the glider is on the ground in a very short time indeed.
- (ii) Leaving it too late to extend the engine to prevent an outlanding. This results in either arriving on the ground prematurely, because the pilot got caught by the drastic loss of performance, or applying full power too soon after starting the engine, leaving insufficient time for warm-up and resulting in complete or partial failure of the engine.
- (iii) Stopping the engine, perhaps at a marginal height, only to find that the engine and/or propeller will not retract because of some failure in the wiring or relay system. This has occurred and it almost led to a very serious accident.

Pilots considering buying one of these "pop-up" powered sailplanes should know that, far from decreasing their margins for (a) shutting off the engine after a launch and (b) making a decision to outland, such decisions must be made much more conservatively than they would be made in a "pure" glider. The flight manual for the AMT-200 Ximango recommends 2,000 feet AGL as a realistic height to start the engine and give

it sufficient time to warm up before applying full power. The Ximango, with its fixed engine installation, is much more "ready to go" than the pop-up designs. Think how much longer it would take in their case.

A further variation on this theme is to bury the engine behind the cockpit, with the propeller driven by an extension shaft which passes through the cockpit and drives a retractable propeller in the nose. This system can only work for side-by-side two seaters, thus allowing the extension shaft to pass between the pilots, and there is only one specimen in production at present, the Stemme S10, seen here.

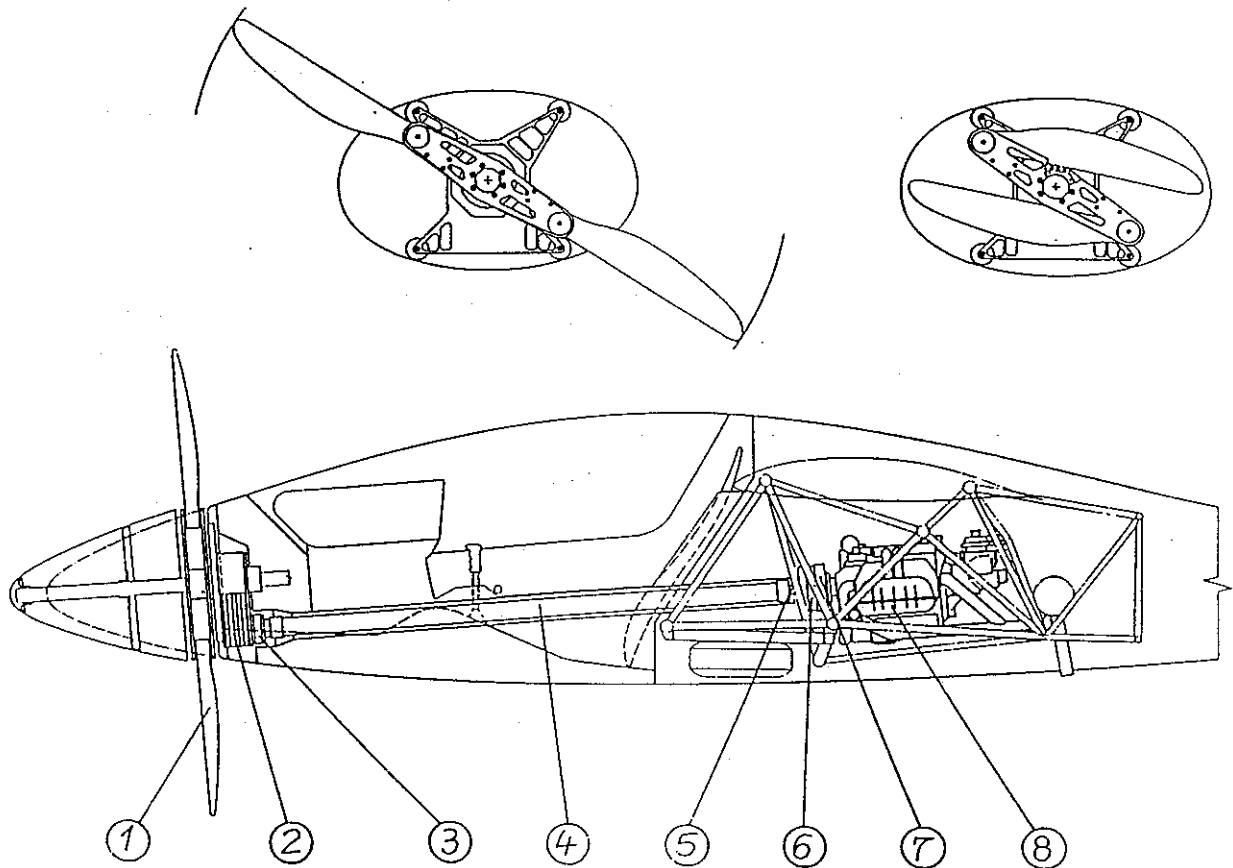

1. **Retractable propeller**  
1.63 diameter in operating position. Extending by centrifugal force, retracting by spring loading, the central body is of aluminium, blades are of fibre composite.
2. **Gear**  
Fivefold high-performance V-belt, gear reduction: 1.07-1.18, quiet operation, fail-safe, maintenance-free
3. **Flexible coupling**  
for compensation of angular alignment
4. **Drive shaft**  
fibre composite, mass: 2 kg, diameter: 60 mm, length: 1.9 m, critical bending frequency:  $\approx 5,200$  RPM
5. **Splined sliding joint**  
for compensation of axial movements
6. **Highly elastic clutch**  
for damping of torque oscillations and for reducing the resonant frequencies
7. **Bivalent centrifugal clutch**  
with servo effects. It damps starting shocks which could be critical for the extension of the propeller, protects against overspeeding, and allows a decoupled slow down of the folding propeller after turning off the engine.
8. **Engine**  
4 cylinders, 4 stroke flat engine, magneto ignition, cooled by ram-air.

### **2.5. Non-retractable engine on a stalk**

These are either homebuilt modifications of existing sailplane designs or factory-designed installations to give a homebuilder the option of building a pure glider or a self-launcher.

Despite some of the designs having folding propeller blades, almost all gliders with non-retractable engines suffer such a loss of glide performance that they have proved unattractive to pilots and have not gained acceptance.

### **2.6. Rear-mounted engine, folding propeller blades**

This type of homebuilt powered sailplane, typified by the American Eaglet, has not gained a great deal of acceptance in Australia and there are only one or two examples in the country.

### **2.7. "TOP" conversions**

These installations, analagous to outboard motors on boats, are available for a range of high-performance sailplanes. They fit over the top of the wing centre-section, resulting in a pronounced hump behind the cockpit. They extend for launching and retract into the hump for gliding. They can be completely removed, leaving virtually no trace that they have ever been there.

With the engine retracted, the hump affects the glide performance to some degree, less than a fixed engine on a stalk, but more than a fully retractable engine. With the engine extended but not running, TOP sailplanes probably suffer a performance penalty which is broadly similar to other retractable types, so the same precautions apply in the case of engine failure on take-off or failure to start for a self-retrieve.

They tend to be rather expensive for what they offer and only a handful of them appeared in Australia.

### **2.8. Jet powered**

There is one type of glider in Australia for which a jet-engine conversion is available. This is the Caproni Calif A21, which can be made into a jet-powered sailplane by the addition of a Microturbo TRS18 turbojet engine of about 90 kgs thrust, the internal fittings being already present. With some additional modification, a twin-engined installation is also possible on this aircraft.

The presence of an engine is not apparent at first glance, until the flush air-intake behind the cockpit and the bifurcated exhausts at the wing trailing edges are detected. The glide performance is unaffected by the presence of the engine.

At the time of publication of this manual, it is not known when Australian certification for the A21J jet Caproni will eventuate.

### 3. DAILY INSPECTION AND PRE-FLIGHT CHECK

#### 3.1. INTRODUCTION

The major difference between a glider and a powered sailplane is the obvious one of the engine. This brings with it other systems associated with the engine, such as the propeller, fuel system and electrical system. Some types may also have hydraulic wheelbrakes. All need to be checked on a Daily Inspection and some need to be checked before each and every flight.

##### 3.1.1. The engine

On a Daily Inspection the engine must be checked for general security of attachment to its mountings and that all connections, such as ignition leads, fuel lines, etc, are secure. A check must be made for obvious leaks of fuel, oil and coolant, as applicable.

On a Daily Inspection and before every flight, oil and cooling systems must be checked and replenished as required. Ensure that only the correct type and grade of oil and coolant are used.

##### 3.1.2. The propeller

The propeller must be checked on a Daily Inspection and before every flight for security, obvious damage and particularly for leading-edge erosion or nicks. In the case of variable-pitch and/or feathering propellers, the blade actuating mechanism must be checked for integrity and freedom from damage.

##### 3.1.3. The fuel system

###### *Refuelling*

Refuelling a powered sailplane requires adherence to a particular procedure. It is not as simple as tipping a few litres of fuel into the tank(s).

Pilots must ensure that the following are checked :

The correct grade of fuel is used. Use of the wrong grade of fuel may cause damage and eventual failure of the engine. In the case of two-strokes without a separate oil system, the correct pre-mixed fuel/oil mixture must be used or in-flight failure is a distinct possibility.

Unless a fuel bowser is used which has been installed by and is regularly inspected by one of the oil companies, proper filtration of the fuel before entering the aircraft's tanks must be assured. This may be done by using a proprietary aircraft refuelling funnel with a built-in filter (such as the "Mr Funnel" product) or by filtering the fuel through a chamois.

Correct earthing procedures must be used. A free stream of fluid from a container is a great generator of static electricity. If the fluid is highly

inflammable, like petrol, there is a risk of fire from a static spark. The only way to ensure that a spark cannot occur is to make sure that there is electrical continuity through every element of the refuelling apparatus and that the whole system is adequately earthed.

Plastic containers for fuel are quite common, as are plastic funnels. Both are poor conductors to earth. Metal containers are better and, if a plastic funnel is used, make sure it contains some graphite for electrical continuity. The "Mr Funnel" product is one such example, containing graphite in its construction as well as having a filter to ensure purity of the fuel entering the tanks.

The recommended earthing procedure for refuelling any aircraft is as follows :-

Aircraft properly earthed by clipping a wire to a metal part of the aircraft, usually the exhaust pipe, the other end of the wire going to a spike inserted into the ground.

Funnel earthed to the aircraft. A metal funnel or the "Mr Funnel" product will earth quite well to the metal mouth of the tank.

The end of the fuel hose or the spout of the hand-held fuel container earthed to the funnel and/or the aircraft. There are usually earthing tags next to the aircraft filler caps.

#### *Checking for contamination*

There are usually two fuel quantities quoted in Flight Manuals, a maximum fuel quantity and a *useable* fuel quantity. This is not some perverse plot to deprive the pilot of useable fuel, but a system designed to trap any contaminants in the lowest point of each tank, then to provide a means of draining off these contaminants to ensure that the rest of the fuel in the tank is clean.

The most common contaminant is water and this is usually the product of condensation in the storage bowser or drums. Provision is made at each tank for this contamination to be drained and thrown away. Most aircraft have an additional drain facility at the lowest point in the fuel system, as well as in each tank.

It must never be assumed that fuel in the aircraft's tanks is clean. Drain checks must be carried out on a Daily Inspection and after any refuelling operation. Failure to carry out these essential checks invites the risk of contaminated fuel reaching the engine (usually at the most critical time, like during the take-off) and causing a completely unnecessary accident.

#### **3.1.4. The electrical system**

On a Daily Inspection, the battery must be checked for correct electrolyte level. Security of attachment, both of the battery to its mounting tray and of the leads to each of the terminals, must also be checked. Check also for any signs of corrosion in the vicinity of the battery.

The security of attachment of other electrical leads should also be checked.



## 4. POWERED SAILPLANE CHARACTERISTICS

### 4.1. THE EFFECT OF UNDERCARRIAGE DESIGN ON HANDLING

Powered sailplanes may have undercarriages of glider type, i.e. with a central mainwheel and either a nose or tailwheel, or they may be fitted with aircraft-type undercarriages, i.e. two mainwheels and either a nose or tailwheel. Examples appear below.

#### 4.1.1. Glider-type undercarriage

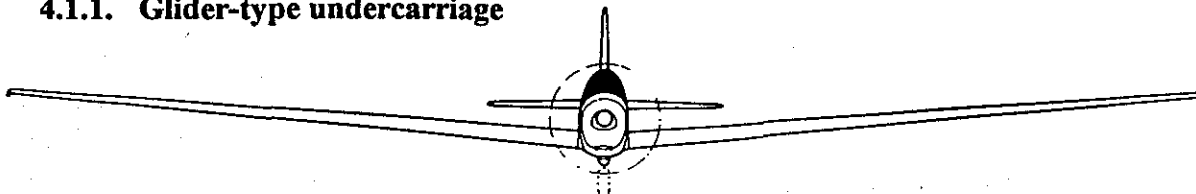

Schleicher ASK14. With this type of undercarriage the aircraft will not keep its own wings level, so this must be done by the pilot. Outriggers may be fitted to assist the pilot to do this, otherwise an assistant is needed for taxiing.

#### 4.1.2. Aircraft-type undercarriage

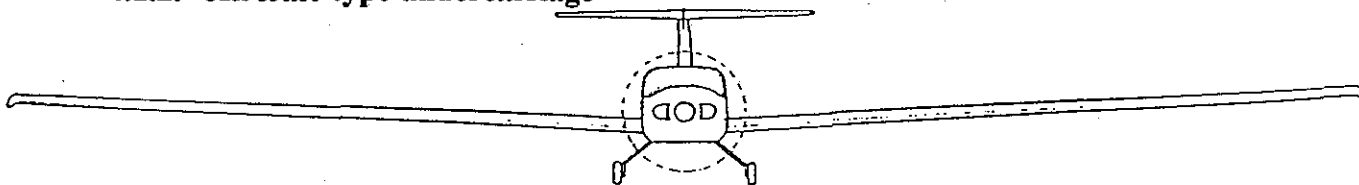

Grob G109B. This type keeps its own wings level and may be taxied like an aircraft

#### 4.1.3. "Nosedragger" design

This design places the mainwheel(s) behind the loaded CG of the aircraft, in other words the aircraft is nose-heavy when on the ground. Nosedraggers have an inherent degree of directional stability. This makes them quite easy to handle on take-off and landing, especially in crosswinds. As a bonus, mounting the mainwheel(s) behind the CG means that nosedraggers have very little tendency to bounce on landing. Despite these advantages, relatively few powered sailplanes are nosedraggers.

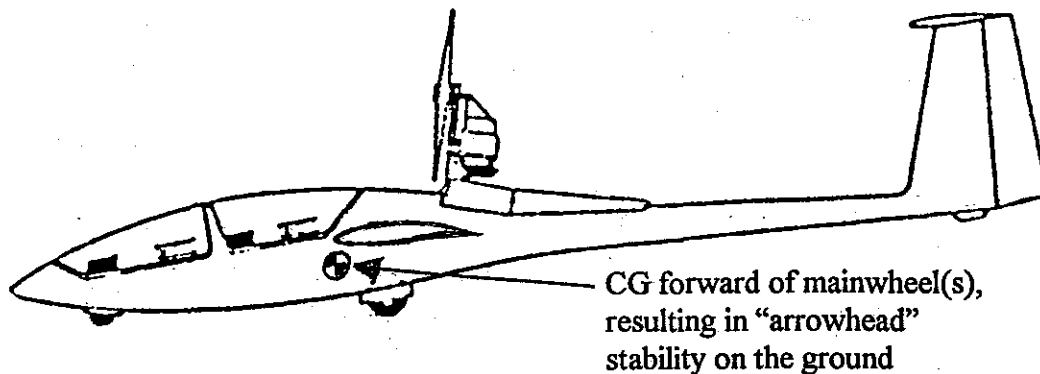

Glaser-Dirks DG500M, showing reason for directional stability

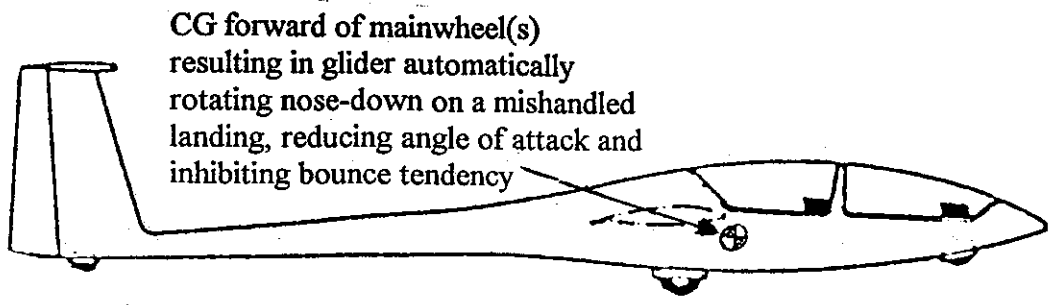

CG forward of mainwheel(s)  
 resulting in glider automatically  
 rotating nose-down on a mishandled  
 landing, reducing angle of attack and  
 inhibiting bounce tendency

Glaser-Dirks DG500M, showing anti-bounce characteristic

**4.1.4. "Taildragger" design**

In this design, the mainwheel(s) are ahead of the loaded CG of the aircraft, thus making it tail-heavy on the ground. Aircraft with this design of undercarriage are unstable directionally and need careful handling to keep straight on take-off and landing. They can be a real handful in crosswinds. They have a tendency to bounce on landing unless landed with accuracy and with the descent rate reduced to zero at touchdown. Most powered sailplanes are taildraggers.

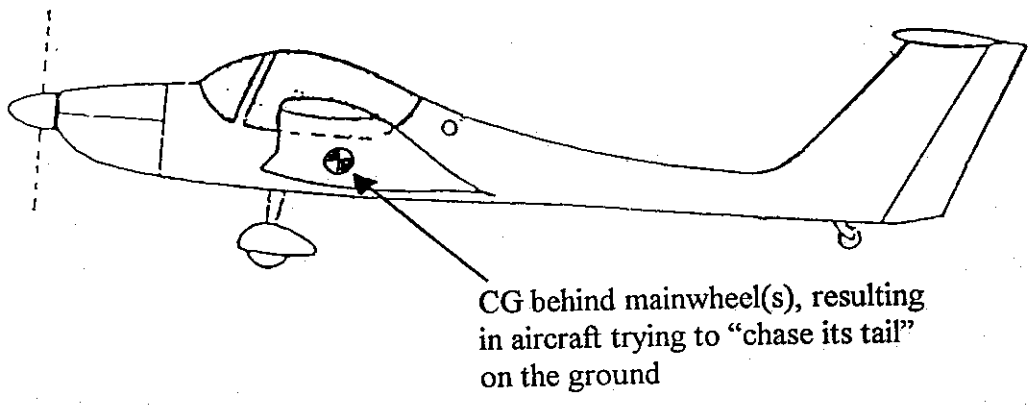

CG behind mainwheel(s), resulting  
 in aircraft trying to "chase its tail"  
 on the ground

Grob G109B, showing reason for directional instability

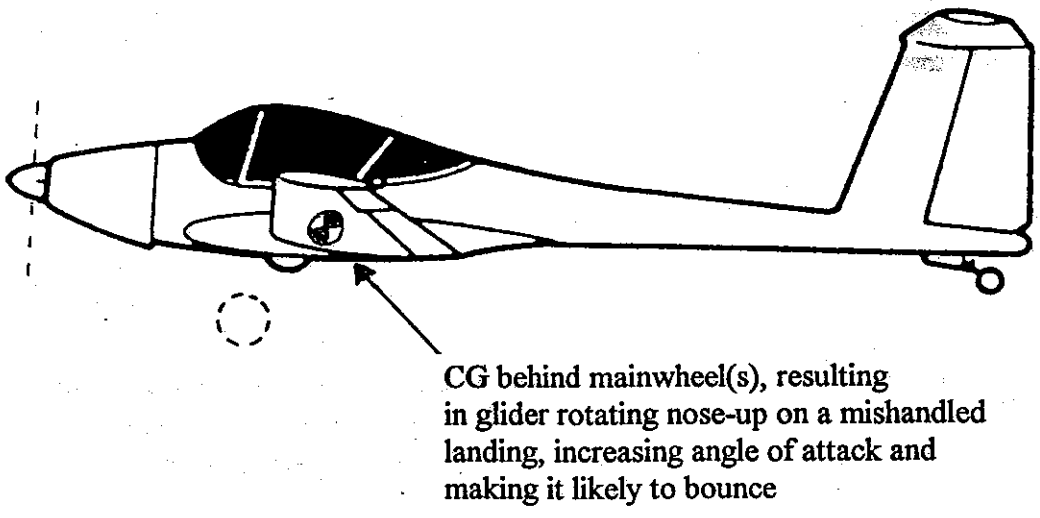

CG behind mainwheel(s), resulting  
 in glider rotating nose-up on a mishandled  
 landing, increasing angle of attack and  
 making it likely to bounce

Brasov IS28M2, showing why taildraggers tend to bounce

#### 4.1.5. Ground-handling and taxiing techniques

Glider pilots are not used to taxiing and the exercise must be consciously learned. All pilots will be unaccustomed to the very long wings of powered sailplanes and they will have to think carefully about wing-tip clearances.

In almost all cases, the steerable tailwheel has limited travel and the turning circle is large. Powered sailplanes and tight spots do not mix well.

In winds over 10 knots, the control positions for taxiing should be in accordance with the following diagram. Arrows denote wind direction. Note that, whenever the stick is forward during taxiing, the wheelbrake(s) must be used with extreme caution.

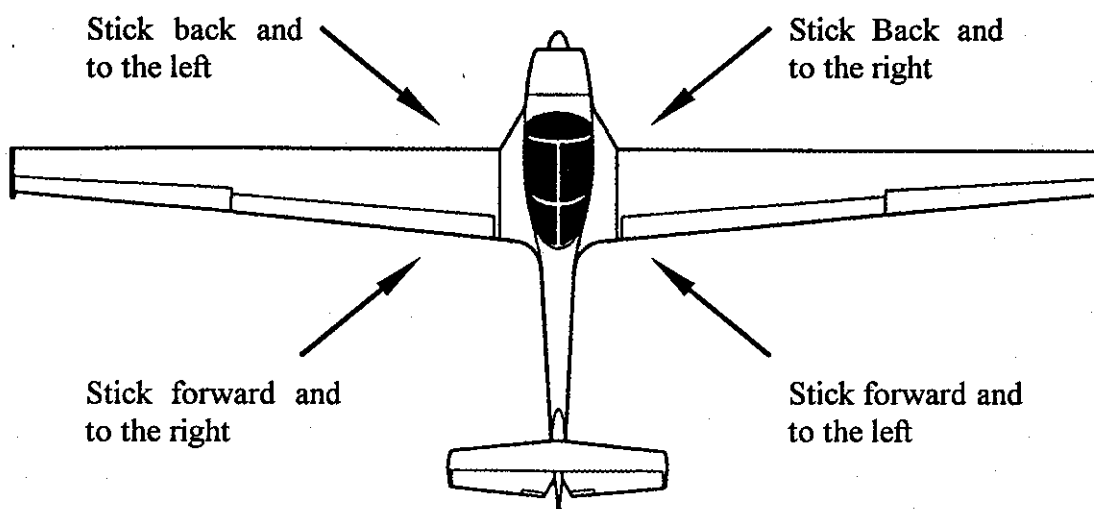

In winds of less than 10 knots, the stick is generally held back.

#### 4.2. THE EFFECT OF THE ENGINE ON HANDLING

The presence of an engine on an aircraft which might otherwise be considered a glider has a number of effects. Glider pilots will have encountered none of these effects before. Power pilots may have seen some or all of them before, depending on what kind of aircraft they have flown. The effects may be summed up as follows :-

##### 4.2.1. The effect of the engine on aircraft trim

A glider pilot will be used to trimming the aircraft when the speed is changed. However, a new notion is the fact that, when the power-setting is changed on a powered sailplane, this has an immediate effect on the trim regardless of whether the speed changes or not. A front-engined design, for example, will have an immediate tendency to pitch nose-up when power is increased and nose-down when it is reduced. Powered sailplanes with their engines in different places may produce different effects. However, they will all produce some change in trim, which has to be learned.

#### 4.2.2. The effect of the engine on directional control on take-off

Most people have heard that powered aircraft sometimes have a tendency to swing to one side on take-off, something that is often loosely attributed to the “torque” of the engine and propeller. Powered sailplanes tend to have so little power and torque in comparison to their General Aviation cousins that they probably wouldn’t swing at all if the above argument were true.

In truth, powered sailplanes often swing quite badly on take-off, even those with only 30 or 40 Kw under the cowling. It is often quite a shock to a glider pilot, who is unused to such behaviour.

##### *Propeller torque*

Although torque is a minor factor in forcing a powered sailplane off its take-off line, it is by far the least important, as it acts in the rolling plane and only really asserts itself in very powerful aircraft, where the torque pushes one mainwheel into the ground and increases the drag on that side. As there are few powered sailplanes with Rolls-Royce Merlin or Wright Cyclone engines, torque effect can be discounted.

##### *Slipstream effect*

The effect of the propeller wash, sometimes called “slipstream effect”, is a bit more significant. The air forced back by the propeller has some spiral motion to it, this striking one side of the rear fuselage and fin more than the other, thus pushing the tail of the aircraft to one side. Although noticeable, it is easily corrected by applying a small amount of rudder to compensate.

##### *Assymetric blade effect*

Another factor causing swing on take-off is the so-called assymetric blade effect, also known as propeller factor, or “P” factor. This comes into play if the aircraft is a taildragger, which means that the thrust line is not parallel to the relative airflow while the aircraft is on the ground.

This causes the the downgoing propeller blade to have a slightly higher angle of attack than the upgoing blade. This in turn displaces the thrust-line slightly to one side of the aircraft’s centreline and produces a swing. Once the tail is raised on the take-off run and the thrust-line is more closely aligned with the aircraft’s take-off path, the effect diminishes. Because “nosedragger” designs have their thrust-lines more closely aligned with the centreline during the take-off run, they have little or no tendency to swing.

Assymetric blade effect is sufficiently marked in powered sailplanes that it can substantially reduce their take-off limit in crosswinds, the limiting case being where the crosswind is coming from the direction in which the aircraft is already trying to swing. This accounts for why some powered sailplanes have very low crosswind limits in their flight manuals. The Grob G109, for example, is only 11 knots and the RF5B Sperber is even lower at a mere 8 knots, beyond which the pilot runs out of rudder control if the crosswind is from the right. The PIK20E (pop-up engine) is also only 11 knots.

Even if there is no crosswind, pilots will notice that there is a need to hold on a noticeable amount of rudder during take-off, just to keep the aircraft straight. This effect of the engine on directional control on take-off is something new for glider pilots to learn, as is the effect on the aircraft's crosswind handling capability. Power pilots brought up on tricycle designs, please consider.

#### **4.2.3. The effect of the engine in the climb**

Once established in the climb, P factor still makes its presence felt, aided and abetted by slipstream effect. The reason for this is that the powered sailplane is still being operated at an angle of attack higher than that for level flight. It must be, or it wouldn't climb. Thus there is still a requirement for the pilot to hold on a certain amount of rudder during the climb, otherwise the slip ball will show that the aircraft is not in balanced flight. Many powered sailplanes (e.g. the Stamo-engined Falkes) will be reluctant to climb if there is any slip or skid showing during this phase of the flight, as the drag produced by unbalanced flight is sufficient to largely negate the meagre amount of thrust available.

Pilots converting to powered sailplanes must become very conscious of their rudder feet and need to get used to referring to the slip/skid ball at frequent intervals during the take-off and climb, to ensure that the aircraft is in balanced flight and the drag is thus reduced to the minimum. Although rudder trimmers are common on single-engined powered aircraft to relieve foot-loads and trim the ball into the middle right across the speed range, there are no examples of such a device being fitted to a powered sailplane. Use your feet.

**Note:** Repeated reference is made to a slip/skid ball, rather than the yaw-string with which most glider pilots are familiar. The reason is that, although a yaw-string may work well on a powered sailplane with its engine on a stalk on the rear fuselage, on a front-engined design it would be permanently affected by propeller wash and, as such, about as useful as an ashtray on a motor-bike.

### 4.3. ENGINE, FUEL SYSTEM AND PROPELLER MANAGEMENT

The management of an engine and its associated systems forms no part of glider pilot training. Power pilots will of course have some background in these particular skills, although this may be of limited use if the powered sailplane is fitted with a two-stroke engine. Ultralight pilots will most likely be better equipped for these engines. Probably none of them will have met one of the variable pitch feathering propellers which are so popular and effective in some kinds of powered sailplanes.

#### 4.3.1. Engine management

##### *Air-cooled four-stroke engines*

These engines, typified by the Volkswagen-derived Stamo, Limbach and Grob examples, are air-cooled four-cylinder engines of horizontally-opposed layout, commonly known as "flat" or "boxer" engines. They operate at somewhat higher RPM than the typical Continental and Lycoming flat engines fitted to light aircraft and differ somewhat in their operating techniques and the facilities offered to pilots.

Major differences between the VW-derived powered sailplane engines and the typical light aircraft engine are :-

1. Ignition systems. Most light aircraft engines are dual ignition, with two magnetos and two plugs per cylinder, giving a degree of redundancy. Powered sailplane engines typically have only one magneto and one plug per cylinder (there are exceptions). If it is a good idea to expect an engine failure at all times in a powered aircraft, it is an even better idea in a powered sailplane.
2. Fuel systems. Most powered sailplanes have a car-type fuel system, which means an ordinary carburettor with a choke for enriching the mixture for cold-starting, but no provision for weakening the mixture. In contrast, aircraft engines also have a carburettor, but they do not have a choke, using a priming system (or an accelerator pump) for cold-starting and a mixture control to weaken the mixture as altitude is gained. This means that a powered sailplane has no means of curing a rough-running engine during take-off at a high density altitude.
3. Induction ice. There may or may not be a carburettor hot-air control fitted. Light aircraft have these as a precaution against induction ice, a common phenomenon when operating in humid conditions at air temperatures between 10° and 20° C.

Some powered sailplanes may have been retrospectively fitted with after-market kits to fix all or some of the above problems. For example, electronic ignition is taking the place of magnetos and fuel-injection systems are replacing carburettors. Even if carburettors are retained, modern examples are altitude-compensated, automatically adjusting their own mixture to prevent rough-running due to excessive richness as altitude is gained.

The common point between VW-derived engines and typical light aircraft engines is that they are all direct-drive, that is the propeller is bolted onto the end of the crankshaft and turns at engine RPM. No gearbox is necessary.

The point to be remembered is that engines in this category may look like a typical light aircraft engine, but they may differ appreciably in the way they are operated and the way a pilot plans to use them. Know your engine and plan your flight accordingly.

There is one other type of air-cooled four-stroke engine fitted to a powered sailplane. This is the Czech Walter Mikron S engine fitted to the L13SW Vivat. It is a four-cylinder direct-drive inverted in-line engine of 48 kW output at 2,600 RPM and is a fully certificated aero-engine. At the time of publication of this manual, there is only one Vivat in Australia and there is no other known powered sailplane application of this engine.

#### *Partially liquid-cooled four-stroke engines*

This type of engine, typified by the Rotax 912 from Austria, has an air-cooled block and cylinder barrels, with liquid-cooled cylinder heads. The purpose of liquid-cooling the heads is to conduct heat away from the critical area around the valves. The Rotax 912 is a high-output engine, producing 58 kW (79 BHP) from only 1,200 cc. It is a fully certificated aero-engine and is found in training aircraft such as the Skyfox Gazelle. It is also fitted to the AMT-200 Super Ximango powered sailplane, which is popular in Australia. It has dual electronic ignition, two plugs per cylinder and two altitude-compensated Bing carburettors.

The Rotax 912 depends on high RPM for its power, which means that a gearbox is necessary to reduce the propeller RPM. Propellers cannot turn at very high RPM, otherwise the tips become supersonic and this creates all kinds of problems, including loss of thrust and a very high noise level (ever heard the awful din made by a Cessna 210 taking off? Supersonic tips at work). The 912 is geared down 2.27:1 enabling a propeller to be used which has good thrust and a low noise level.

Most power pilots will not have met a geared engine before and will need to get used to 5,500 engine RPM for take-off. Otherwise the engine operates like any other.

Smooth and trouble-free running over the full range of RPM makes air-cooled or partially liquid-cooled four-stroke engines suitable for installation in powered sailplanes which may be used for engine-on cruising for prolonged periods, in the manner of a light aircraft.

#### *Two-stroke engines*

These may be either air-cooled (e.g. 17.6kW/24 hp Rotax 275 in ASW24E) or liquid-cooled (e.g. 44kW/60 hp Rotax 535 in Glaser-Dirks DG500M). They all turn at high RPM and are all geared down to their propellers, typically 3:1, by gearbox or belt.

Some Flight Manuals warn against cruising two-stroke engines at reduced power, partly because of oiling up of the plugs, partly because of a carbon build-up in the cylinder barrels. This effectively means running the engines at full power (or at least

very high power) or not at all. This in turns means that powered sailplanes fitted with these engines are not intended for prolonged engine-on cruising, but for self-launching, the engine to be operated at full power for the climb, then shut down when sufficient height is gained and the sailplane used for its intended purpose, soaring.

#### **4.3.2. Engine shut-down - all types**

As a general rule, engines cannot be shut down instantly. There will usually be a cooling-down period before stopping them completely and this varies from type to type. Air-cooled engines are especially critical. An engine which has been running at full power generates very high local temperatures, especially around the valves. These locally high temperatures must be given a chance to equalise themselves with the rest of the engine and enough time allowed for the general engine temperature to stabilise. This may take as long as several minutes and usually consists of reducing power in stages rather than in one hit.

Obviously the decision to shut down an engine must be made well in advance. If this is not done, and if the proper shut-down procedure is not followed, the engine will suffer damage. Such damage, examples of which are cracked cylinder heads or bent valve-stems, is cumulative and the eventual failure may occur at a later date to a pilot who is handling the engine quite correctly and following the correct shut-down procedure to the letter.

Liquid-cooled engines are less critical than air-cooled engines, as their temperatures are stabilised by the coolant surrounding the critical areas. Nevertheless, they should not be handled roughly and the same basic principle of shutting down in stages should be followed as for air-cooled engines.

If all else fails, read the instructions. Flight manuals vary greatly in the amount and quality of information presented to the pilot, but there will often be some good guidelines for engine handling and these should be observed in day-to-day service. There will sometimes be separate manuals for aircraft and engine (e.g. AMT-200 Super Ximango and Rotax 912). If there is no guidance, you will not go far wrong following the shut-down advice offered here.

There is one particular failure mode which pilots of retractable engine/propeller machines should be aware of. This is failure of the engine to retract, usually because of loose wiring or some other electrical problem. This problem would obviously not occur to a manually retracted engine, such as the PIK20E. If it does occur, you are probably best off starting the engine again and landing as soon as possible, unless of course you are out of fuel!

#### **4.3.3. Induction icing**

Almost all powered sailplane engines have carburettors - fuel injection systems are rare in these machines. If a carburettor is fitted, induction icing is possible. It traps many pilots and the biggest reason for this is the fact that it occurs at air temperatures considerably above freezing. In fact, if the air is at freezing temperature, induction icing is virtually impossible.



Induction icing occurs like this :-

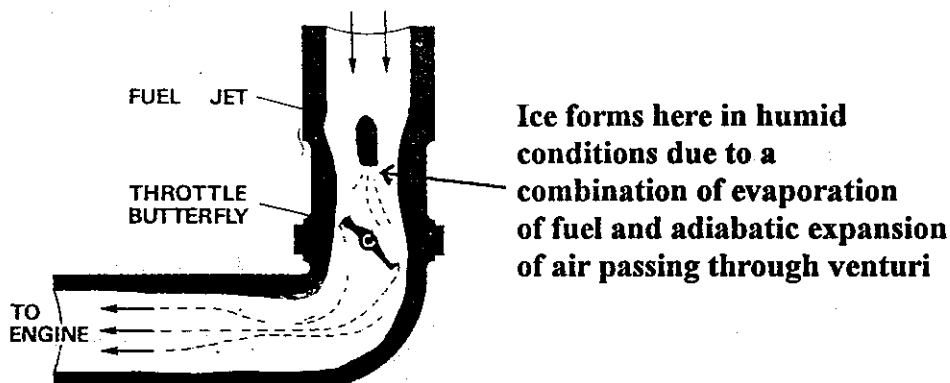

Unlike airframe icing, you do not have to be in cloud to experience induction icing. It will form in clear air. The most likely atmospheric conditions for the formation of induction icing are

1. Air temperature between 5° and 30° C, with 15° being the most dangerous temperature. Icing has occurred as high as 40° C.
2. Relative humidity greater than 50%

If you are flying on a warm day with fairly high humidity, induction icing can be expected. It is more likely to occur at intermediate power settings and probably will not occur at full power, as the drop in temperature in the carburettor throat is so rapid at full throttle that the ice particles form in the air and do not build up on the sides of the venturi. However if you have been at an intermediate power setting and you pick up induction ice, it may prevent you from getting full power. Be constantly on the alert on warm humid days.

Induction icing will not occur at freezing air temperatures, because the air enters the carburettor already frozen and any tiny particles of ice which may be present enter the inlet tract harmlessly and are consumed by the engine. In these conditions, no build-up of ice can occur on the sides of the venturi or inlet tract and the engine will not choke itself to death.

#### *Use of carburettor hot-air*

If the engine is fitted with a carburettor hot-air control, it should be used as a precaution whenever the engine is throttled back from full power on any day on which icing is likely. Even if it is not considered likely, it can do no harm to select hot air every time you reduce power.

There are four important things to keep in mind when using the hot-air control :-

1. Use it as a preventative measure. Keep your eye on conditions and select hot-air BEFORE you experience icing, otherwise you may not get the chance to use it once icing has occurred and the engine has started to lose power. The hot-air is supplied from a jacket surrounding the muffler - once the engine

has started to suffer progressive failure, the supply of hot-air becomes less and less.

2. Always select FULL hot-air. Selecting partial hot-air could produce induction icing where none previously existed, by raising the temperature by just the amount to put you exactly into the icing range.
3. Do not apply full power with hot-air selected. This could cause overheating and/or detonation, possibly leading to damage or failure.
4. Be very cautious about using the hot-air control on the ground, as it bypasses the engine inlet filter and thus allow unfiltered air into the engine. Only use the control sufficiently to burn off any ice which may have built up during taxiing, then select it back to cold-air before applying full power.

What if your powered sailplane does not have a carburettor hot-air control? In this case you have no choice but to avoid icing conditions and this means that you must be fully aware of the conditions which promote its formation.

Be especially alert to the build-up of induction icing while taxiing out for take-off. If this occurs, it can quite easily prevent you from getting full power. By the time you have noticed the shortfall in power, you may find that your take-off run has been severely compromised and you're not going to make it. This has almost certainly been the primary cause of a number of powered sailplane take-off accidents which have occurred over the years.

Finally, what if you are happily motoring yourself back to base from a failed cross-country task, when you blunder into induction icing conditions in a machine which has no hot-air control. Welcome to Farmer Brown's paddock, because that is where you are likely to end up unless you have anticipated the onset of icing and have applied full power before it strikes.

#### **4.3.4. Density altitude**

What a pilot sees on the altimeter is known as "pressure altitude". If, at the altitude of the strip from which a powered sailplane is being operated, the air is less dense than it should be (in comparison with the "International Standard Atmosphere", based on a temperature of 15°C), the altitude readout will not be accurate.

The biggest influence on altitude reading is temperature. An increase in temperature results in a decrease in density. In one particular accident which occurred to a powered sailplane, a take-off was being attempted from an airfield at 630 feet above sea-level. The temperature was 37°C on that day. Putting these two figures through a density altitude calculator (known to pilots as a "prayer wheel"), this gave an "apparent" altitude of about 3,000 feet. This apparent altitude is known as the density altitude.

The effect of density altitude in the above example was that the air was thinner than it ought to have been at 630 feet. The air was in fact the same "thin-ness" as air at 3,000 feet. This had two effects on the attempted take-off :-

1. Both the power output of the engine and the lift produced by the wings were below the values to be expected at 630 feet.
2. The true airspeed was higher than the indicated airspeed, resulting in a longer take-off distance.

In summary, the above example shows a performance loss of some 5% in conditions which would be considered quite normal in many parts of Australia in summer. Imagine how much worse the problem would have been if the take-off were attempted at a location like Bond Springs, NT (the home of the Alice Springs Gliding Club), where the strip altitude is 2,400 feet above sea-level and a 37°C day would be considered quite mild in summer.

When dealing with density altitude, what you see is not necessarily what you get. You must know the effects of density altitude on take-off and climb performance and if in doubt, err on the conservative side.

If you want to work some examples of density altitude, buy yourself a navigational computer or borrow one from your PPL friend and crunch a few numbers in the density altitude window.

As a final comment, some powered sailplanes have plenty of power available and will be reasonably tolerant of high density altitudes. However, others are distinctly marginal in their take-off and climb performance under sea-level and quite cool conditions, but are very adversely affected as the density altitude rises. Marginal performance becomes dangerous non-performance very quickly when the summer heat is turned on, even if conditions remain fairly smooth. Imagine how much worse matters will be if thermals are going to a great height and an attempt is made to take off into a large area of the accompanying sink. A pilot doing this stands a good chance of becoming a new topographical feature on the landscape if luck is pushed too far.

#### **4.3.5. Tug-assisted launches**

An emerging trend in some parts of the world is to use an aerotow to assist a retractable-engine powered sailplane for the take-off and early part of the climb. This is quite simply because some modern powered sailplanes are underpowered. Just how a powered sailplane finds itself in need of external assistance yet still meets the certification requirements is unclear.

Whatever the answer, it is likely that the density altitude problems which are common in Australia will add to the poor basic performance to make the tug-assisted launch attractive to operators of this breed of marginally powered sailplanes.

To carry out this launch, the tug is attached and carries out a normal aerotow, and the powered sailplane's engine is also used at full power. Exactly who is augmenting whom is a debatable point, but it is clearly important for everything to keep working properly if a nasty accident is to be avoided.

Possible problems which must be considered are as follows :-

1. Engine failure in the tug. The glider pilot with the throttle at flat chat will need to be very quick off the mark to release the rope and carry out an evasive manoeuvre if the tug's engine quits, otherwise the glider stands a very good chance of catching up with a rapidly decelerating and descending tug, which would not be a pretty sight if it succeeded in doing so. The alternative is for the glider pilot to close the throttle in order to decelerate and maintain separation from the tug, but this means that the glider will probably descend like a stone and the end result will be two aircraft in a paddock instead of one. There may be a useful increase in the safety of this failure mode if high-tow is used instead of low-tow, as the tug would fall clear of the powered sailplane instead of on top of it. Even so, the powered sailplane is still left hanging in the air with insufficient power to climb on its own. Remember that this is why this exercise was being carried out in the first place.

2. Rope break. Not as serious as tug engine failure, because there is not as high a risk of collision with the tug. There remains the problem of the shortfall in performance on the part of the powered sailplane, which could still cause an accident. Worse than a pure glider rope-break because, if a break does occur and the machine is sinking even at full power, a successful landing in a paddock would be a lot more complicated to accomplish safely.

3. Wave-off. Similar to the rope-break, but could worsen if followed by tug engine failure after the wave-off. This would make it similar to 1 above.

4. Release from the tug end. If operating in low-tow, releasing from the tug may result in the rope going back over the glider's wing and fuselage. Not a great problem for a pure glider, but entanglement with a powered sailplane's engine running at full power can be imagined. Probably cured by operating in high-tow.

5. Engine failure in the powered sailplane. Given the very high drag with the engine extended but not running, the tug pilot must be on the alert for engine failure in the powered sailplane. A climb which looks normal one moment can turn into something quite different if the drag on the back suddenly increases by a factor of... goodness knows what. A tug pilot in this situation is in a real dilemma - to release the powered sailplane and leave it to its own devices, knowing that its severely hampered performance makes a safe landing unlikely? Or try to keep going and put the entire combination at risk? The high drag and poor glide performance of a powered sailplane with a failed engine sticking up into the breeze makes this decision much more difficult for the tug pilot than if it was a pure sailplane on the back

#### **4.3.6. Fuel management**

Any engine is only as good as the fuel which is fed to it and there is nothing quite like the sudden silence which follows fuel starvation or exhaustion.

Powered sailplane fuel systems fall into two categories. Firstly the very simple gravity-feed system with a single tank, a simple on/off selector and nothing else (e.g. Scheibe Falke). Secondly those with multiple tanks, left/right selector valves and electric

booster pumps (e.g. AMT-200 Super Ximango). Some may have engine-driven fuel pumps as well. All systems need to be learned, it's just that some need more learning than others.

A distinction is made between fuel starvation and exhaustion. There is a fundamental difference between the two. Fuel starvation means that the engine is starved of fuel, even though there is plenty in the tank(s). A malfunction or a wrong selection is usually the culprit here.

Fuel exhaustion is just that - nothing left in the tank(s). This is occasionally caused by a freak problem, such as springing a leak, but is usually all the pilot's own work, like taking off with insufficient fuel.

One of the basic problems which leads to poor fuel management lies in the nature of the powered sailplane itself. It is not really a glider, but neither is it really a powered aircraft. Pilots are sometimes uncertain what kind of pre-takeoff check list to use in order to cover all the items satisfactorily.

The GFA recommendation is to use the basic glider checklist, CHAOTIC, then add the items appropriate to the additional equipment fitted. Such items might consist of :-

Fuel - selected "on" and appropriate tank decided upon if more than one tank fitted, contents sufficient and booster pump (if fitted) on.

Cowl flaps - open.

Propeller - pitch fully fine.

Some pilots may prefer to use a checklist provided by the manufacturer and quoted in the flight manual. This is fine for private use, provided that all the items are covered, but if it is a training exercise, it is preferable to use the GFA checklist plus extras.

All aircraft fuel systems are designed to have some unusable fuel in the tanks. This is a deliberate design feature to allow a low-point in which water and other contaminants may accumulate. Part of the pre-flight check on a powered sailplane is a water-check, a sample being taken from this low point in each tank, and often from the lowest point in the entire system. This is an essential part of the pre-flight check.

This is an appropriate point to offer the reminder that the three most useless things to a pilot are the height above you, the runway behind you and the fuel in the bowser.

#### **4.3.7. Propeller management**

Many powered sailplanes have fixed-pitch propellers. These are simple and generally trouble-free, provided they are looked after properly and carefully checked before flight. The material is often wood, usually with a metal leading edge to combat abrasion, but composite propellers (usually carbon-fibre) are also popular.

### *Propeller pitch*

Before going any further, it is appropriate to explain the meaning of propeller "pitch". Pitch is defined as the distance moved through the air for one revolution of the propeller and is governed by the angle of the blade in relation to its hub.

A propeller which travels a long way through the air for each revolution is said to have "coarse" pitch, sometimes known as "high" pitch. A propeller which travels only a short way through the air is said to have "fine" pitch, also called "low" pitch.

A coarse pitch propeller, although it travels a long way through the air per revolution, puts quite a high load on the engine and prevents high RPM from being achieved. It is analogous to high gear on a motor car. Fine pitch allows the engine to rev more freely and is analogous to low gear on a car.

A coarse pitch propeller is good for cruising, but because it limits the RPM produced by the engine, gives poor performance for take-off and climb. A fine pitch propeller is good for take-off and climb, but the engine tends to over-rev in the cruise and this forces the pilot to reduce the throttle setting to avoid engine damage.

### *Fixed pitch propeller*

A fixed pitch propeller is of necessity a compromise - fine enough to allow the engine to develop plenty of power for take-off, but coarse enough so that cruise speed is not limited by over-revving. It is not possible for a fixed pitch propeller to do both jobs really well.

Fixed pitch propellers have the virtue of simplicity and they are popular for that reason. They need little management in flight, beyond keeping an eye on the tachometer to make sure the RPM limitations are observed. This is not a problem in a powered sailplane used purely for self-launching, where the low climb speed keeps engine RPM within limits and there is no intention to cruise the aircraft engine-on. However, if engine-on cruising is intended, the pilot will need to keep a careful eye on engine RPM as the aircraft is levelled off, throttling back as speed builds up until the right compromise of cruise speed and RPM is reached. From that point, any speed change will be an RPM change and the pilot needs to be aware of this too.

### *Variable pitch propeller*

Ultralight pilots will be familiar with propellers which are able to have their pitch changed on the ground. The pilot is therefore able to choose whether to bias the propeller in favour of the climb or the cruise. It is a useful feature to have on a propeller, but is of limited use because it cannot be adjusted in flight.

Variable pitch propellers which are adjustable in flight are quite common in powered sailplanes. They are usually mechanically operated, rather than the hydraulic or electrical systems which tend to be favoured by powered aircraft.

The propeller adjustment control is usually a large lever in the centre of the instrument panel of a powered sailplane. To make an adjustment, it is usually necessary to reduce

power (RPM) quite considerably before making the pitch-change, something that power pilots will definitely not be used to.

The following extract from the flight manual for the AMT-200 Super Ximango (Rotax 912 with Hoffman propeller) will give an idea of the procedure to change propeller pitch when transferring from the climb at 5,500 RPM into cruising flight :-

“Propeller pitch - cruise (procedure performed at 3800 RPM by moving the pitch lever approximately 30 degrees to the left and returning to the original position). Observe that RPM will reduce below 3,300 RPM. Throttle is then adjusted for continuous operation between 4,000 and 5,400 RPM.

**NOTE:** If it is necessary to change the propeller maximum pitch (coarse) to the minimum pitch (fine) with the engine in operation, reduce the RPM to 2,200 - 2,400 and pull the pitch lever at 30 degrees to the left hand returning to the original position: observe that RPM will increase.

The pitch change should be made under 54 knots to reduce the pilot effort at the pitch lever during this procedure”

Whether a pilot is coming to this kind of propeller from gliders, ultralights or GA aircraft, operation of the pitch-change mechanism must be the subject of specific training. If this is not done, problems of an operational or airworthiness nature, perhaps both, will result.

### *Feathering propeller*

A powered sailplane is designed with the intention that the engine will be used primarily for self-launching and shut down when sufficient height has been gained to find some kind of lift.

When the engine is stopped, the drag of the propeller blades is quite considerable, as they are presenting their flat aspect to the airflow. Its a bit like flying around with the airbrakes partly opened. It saves quite a lot of drag if the pitch of the blades can be changed to align them with the airflow. This can in fact be done and the process is known as feathering.

Feathering the propeller is simply coarsening the pitch of the blades until an angle of approximately 90° is reached. Referring once again to the flight manual for the Super Ximango, the pilot is instructed to “reduce airspeed below 54 knots, move propeller to the feather position by moving the pitch lever to the extreme left position, then turn the propeller to the horizontal position using the starter”.

All variable pitch propellers fitted to powered sailplanes have a feathering function. However, no similar facility is available with a fixed pitch propeller.

### *Propeller brake*

Some propellers are fitted with a brake, applied by a lever which is usually mounted on or under the instrument panel. This assists the pilot to bring the propeller to a stop after the ignition has been switched off.

### *Constant-speed propeller*

A constant-speed propeller automatically adjusts the pitch-angle of the blades to keep the engine at any selected RPM, as initially set by the pilot. It may be electric or hydraulic in operation and adds considerably to the weight, complexity and cost of the aircraft. At the time of publication of this manual, the only powered sailplane which offers the option of a constant-speed propeller is the Stemme S10.

#### **4.3.8. Engine starting in flight**

##### *Electric or "pull" start, fixed pitch propeller*

Most powered sailplanes are fitted with electric starters, although some are fitted with the lawn-mower type of pull starter using a cord or cable. With these types, all the pilot needs to do is to set the engine and fuel system controls in accordance with the flight manual recommendations and start the engine.

Having started the engine, it must be warmed up properly before full power is applied. This means that the need to start the engine must be anticipated and the engine started in good time to prepare it to take full power (2,000ft AGL minimum recommended).

Leaving the decision to start the engine until too late is the most common problem in the operation of powered sailplanes and on average there is at least one accident every year from this cause. A late decision to start the engine can have one of two consequences :-

1. The engine may refuse to start. In the case of a retractable-engine machine, this causes great problems because of the very low performance with the engine extended but not running. If the decision is made only a few hundred feet above the ground and the engine doesn't start, it is likely that a safe landing in a paddock will be more a matter of luck than anything else.
2. The engine may start but there will be insufficient time for a proper warm-up. When you need full power to "save" a late outlanding decision, the engine will balk and in all probability will fail completely.

##### *Electric or pull start, variable pitch feathering propeller*

The engine and fuel system controls are set in accordance with the aircraft's flight manual and the propeller is moved from the feathered position to the fine pitch position (extreme right position for a Hoffman feathering propeller). The engine is then started.

The same warnings about warm-up procedure and late starts apply.

##### *"Windmill" start*

This method of starting relies on the powered sailplane's speed to get sufficient airflow through the propeller to start the blades windmilling. For most powered sailplanes, a minimum of 90 knots is necessary and some of them need more than this.



Even this kind of speed may not get the blades turning. It may be necessary to build up speed, then pull up at about 3G. This alters the angle of attack of the airflow around the blades and will often get them turning when speed alone has failed (the manufacturers don't tell you this).

The windmill method of starting is considerably more height-consuming than using the aircraft's starter. However, if the battery goes flat, the starter fuse blows or the pull-cable breaks (remarkably common), it is the only chance you have got. Get plenty of height one day and practice doing it.

When doing this kind of start, note your height at the beginning of the manoeuvre and note it again when the engine has started and is beginning to warm up. Jot down the figure you get and never, never forget it. While you are at it, do it for all methods of starting the engine in flight.

Final note on engine starting procedure. When the RPM are being progressively increased to warm up the engine, remember the risk of induction icing. This period of warm-up is a classic time for pilots to get caught by this old enemy of ours.

#### **4.3.9. Mixture control**

As altitude increases, air density decreases. This results in the fuel/air mixture becoming richer with height (less air, same amount of fuel). This increasing richness will eventually cause rough running of the engine and considerable loss of power.

It is the density altitude that matters, not the pressure altitude. Thus you could be in trouble even on the runway if it is a hot day at an elevated aerodrome. Section 4.3.4. covers density altitude and will remind you of the factors involved.

Some carburettors have automatic compensation and will weaken the mixture as altitude is gained (e.g. "Bing" carburettors on Rotax 912). "Conventional" aircraft engines such as a Lycoming or Continental, are fitted with a manual mixture control which is adjusted by the pilot. Some engines have nothing at all. Know your engine, know the factors which affect the engine's mixture and be aware that, if you cannot weaken the mixture at high density altitudes, you should be ready for a longer take-off run and a degraded climb under such conditions.

#### **4.3.10. Powered sailplane landing characteristics**

On the face of it, a powered sailplane should not present any more difficulties in the landing phase than either a pure glider or a powered aircraft. This is true up to a point, but when the problem is examined in more detail, two particular problems come to light which do not exist in the other machines.

##### *Too many controls or not enough hands?*

This problem does not arise when landing a powered sailplane engine-off, in other words as a pure glider. However, if the aircraft is to be landed engine-on, the pilot finds that the right hand is occupied with the stick and the left hand operates the airbrakes, as per normal gliding practice. This leaves no hand available to operate the

throttle. Given that the throttle controls on many powered sailplanes are spring-loaded to the open position and the friction devices are not always reliable, this can make life interesting near the ground. This problem has caught out many instructors and possibly accounts for why almost all Falke powered sailplanes (using these just as an example) have suffered propeller strikes during botched engine-on landings. This makes a powerful argument for switching off the engine and landing them as gliders.

#### *Insufficient or wrongly-placed airbrake controls*

Some side-by-side two-seat powered sailplanes have poorly designed airbrake controls in the cockpit. Two particular design faults cause problems for pilots, viz.

1. Only one airbrake control, mounted between the two pilots. This causes trouble for a glider pilot, who has to fly left-handed on the final approach in order to operate the airbrakes if he/she is sitting in the left seat. Most glider pilots are not used to flying left-handed. The solution might be to put the pilots in the right seat, but be careful here, because the instructor is now the one who has to fly left-handed and may have to do so suddenly and with little warning, to correct a situation near the ground. He, too, might be out of practice in flying left-handed. Powered sailplanes which such a design feature should not be used for training.
2. Two airbrake controls, but mounted on each cockpit wall, to the left of the left-seat pilot and to the right of the right-seat pilot. This is fine for left-seat pilots, but right-seat pilots beware. Refer to 1. above.

#### **4.3.11. Landing with engine extended but stopped**

Arguably the most troublesome situation in powered sailplanes with retractable engines and/or propellers is the random failure of the engine in flight or the failure to start when it is needed. The effect of this situation on the glider's performance has already been covered elsewhere in this manual.

During conversion to a powered sailplane of this type, it is recommended that the pilot practise at least one circuit and landing with the engine extended but not running. This should be done under controlled conditions at the pilot's home field, starting overhead or nearly overhead the field with plenty of height and informing others of the intended exercise. Follow any Flight Manual recommendations that may be offered, with respect to procedures, speeds, flap settings, etc. If nothing is offered, at least make sure the glider does not get slow in the very high drag configuration and aim to land long so as to provide a buffer against an unexpected undershoot.

It is much better to try this exercise in the above manner than to be faced with a totally unfamiliar situation when the engine fails to start on a cross-country flight. It is probably a good idea to repeat the exercise at least once a year to ensure ongoing proficiency. The preferred time to do it would be just before the start of the cross-country season.

## 5. TRAINING AND CONVERSION REQUIREMENTS

### 5.1. ALL-THROUGH TRAINING IN POWERED SAILPLANES

#### 5.1.1. General

In principle pilots may be trained from scratch to fly powered sailplanes and to qualify for the various GFA certificates and FAI badges in them.

However, some of the two-seat powered sailplane types likely to be used for basic training are non-aerobatic and as such are not permitted to carry out spinning. Any operation using one of these types (consult the Flight Manual to check if spinning is permitted or not) is required to have access to some type of aircraft, either powered or glider, which will satisfactorily carry out the spin segment of a pilot's training.

It should be noted that, although powered sailplanes are VH-registered, they are kept on that part of the register administered by the GFA and, as such, are not permitted to be used as powered aircraft for the training of a power pilot to licence standard, unless they are transferred to the General Aviation register and come directly under the jurisdiction of CASA.

#### 5.1.2. Syllabus of basic powered sailplane training

The sequence for training a pilot from scratch to be a powered sailplane pilot is as per GFA Instructor's Handbook for the training of glider pilots, with the addition of the following items :-

##### *Local flying only*

- Fuel handling, refuelling procedures, checking correct fuel grade
- Checking fuel system for water or other contamination
- Daily inspection of engine and systems
- Starting procedures, especially safety precautions
- Engine handling and warm-up procedure
- Taxying
- Additional items in pre-takeoff check
- Engine and propeller effects on take-off, especially in crosswinds
- Engine limitations and monitoring engine parameters during take-off/climb
- Propeller pitch-change procedure on climb and during cruise, if applicable
- Cowl-flap adjustment, if applicable
- Climb pattern, compensating for blind-spots
- In-flight shut-down procedure
- Propeller feathering procedure, if applicable
- Engine and/or propeller retraction procedure, if applicable
- Engine and/or propeller extension procedure, if applicable
- Propeller unfeathering procedure, if applicable
- In-flight starting procedure - normal
- In-flight starting procedure - windmilling
- Glide performance in case of engine/propeller extended but engine not running,

if applicable

Additional items in pre-landing check

Engine-on landings, if permissible or practicable on type

Engine-off landings

GFA radio operator's logbook endorsement (Note: Necessary for local flying at all times in an MBZ or if aircraft is radio equipped and operating in a CTAF. Not necessary for non-CTAF/MBZ operations))

### *Cross-country flying, engine-on*

FAI Silver badge PLUS two additional cross-country flights in excess of 50 kms PLUS oral test on basic navigation (see Section 6). Alternatively, Private Pilot Licence or AUF Pilot Certificate with cross-country endorsement (see Section 6.1. (a)).

GFA radio operator's endorsement, or equivalent GA/AUF authorisation

ICAO cruising levels

Radio requirements in all classes of airspace

Clearance requirements in applicable airspace classes

Transponder requirements in applicable airspace classes

Minimum fuel reserves

Daylight and darkness graphs

MBZ and CTAF requirements and procedures

Awareness that flight must not be continued into deteriorating weather, nor above 8/8 cloud

## **5.2. CONVERSION FROM GLIDERS TO POWERED SAILPLANES**

As per 5.1. above added to existing gliding qualifications

## **5.3. CONVERSION FROM POWERED AIRCRAFT AND ULTRALIGHTS TO POWERED SAILPLANES**

For conversion of General Aviation (GA) and ultralight pilots to powered sailplanes, each case will need to be considered on its merits, depending on the pilot's previous experience and the type of powered sailplane to which the conversion is being made. Factors to be considered are as follows :-

### *Previous experience*

Whether the pilot has mainly taildragger or nosewheel experience

Whether the pilot has mainly two-stroke or four-stroke experience

Whether the pilot has any experience with variable-pitch or constant-speed propellers

### *Powered sailplane type*

The previous experience listed above should then be applied to the type of powered sailplane to be used for the conversion and the training tailored to make maximum use of that experience.

## 6. BASIC NAVIGATION

### 6.1. GENERAL

When flying cross-country under the Visual Flight Rules (VFR), the basic principles of navigation apply. This chapter outlines these principles so as to give sufficient information to help a new cross-country pilot to avoid getting lost or straying into an area where he/she should not be.

The requirement to be trained in accordance with this section is waived if the pilot converting to powered sailplanes holds either of the following :-

(a) A Private Pilot's Licence (Note: This means either the present plastic card licence or the old green book licence stamped "Restrictions Lifted". The old Restricted licence is not sufficient).

or

(b) A pilot certificate issued by the Australian Ultralight Federation and endorsed for cross-country operations.

### 6.2. MAPS, CHARTS AND OTHER ESSENTIAL DOCUMENTS

#### 6.2.1. The World Aeronautical Chart

The most common type of map used by VFR pilots is the World Aeronautical Chart (WAC). The projection used on these maps is Lambert's Conformal Conic, a fact which is of little interest to pilots. The scale used on a WAC is 1:1,000,000, which is of great interest to us. Such a scale means that large areas of country are covered by a single map, avoiding as far as possible the unpleasant business of trying to change and unravel maps in flight. However, Australia is such a large country that carrying more than one map is sometimes unavoidable. The WAC scale gives relatively little detail, but in fact provides enough for the commonly used turning points and navigation check points used by VFR pilots to be quite easily identified.

#### 6.2.2. En-Route Chart, Low (ERC Low)

The ERC Low chart is useless for VFR navigation, as it contains no topographical information except coastlines and lakes (without names). The usefulness of a ERC Low for a VFR pilot is that it contains all the controlled airspace classes and boundaries, GPS coordinates of public aerodromes, MBZ boundaries and all radio frequencies. An ERC Low chart is essential for responsible cross-country flying, especially if it is intended to seek clearance to enter controlled airspace during the flight.

#### 6.2.3. Visual Terminal Chart (VTC)

As implied by its title, this chart covers the area immediately surrounding large aerodromes which have Class C and D Control Zones. They have topographical detail as well as information on controlled airspace boundaries and frequencies. These charts

are essential for pilots who are (a) based at aerodromes depicted on VTCs or (b) intending to transit aerodromes or associated controlled airspace depicted on VTCs.

All maps and charts are available from the Airservices Australia Publications Centre, P.O. Box 1986 (715 Swanston Street), Carlton, 3053. The Australia-wide free call is 1300 306 630 or 9342 2000 if you are calling in the Melbourne area.

### **6.3. TRACK, DRIFT, HEADING**

#### **6.3.1. Track**

When planning a cross-country flight, one of the first things a pilot does is to draw lines on the map from the departure point to either the goal destination or to various turning points on a closed-circuit task. These lines represent the path to be followed by the glider over the ground. The correct term for such a line drawn on a map is the **TRACK**. To be finicky about it, the strictly correct term would be **Track Required**, but the important thing to remember is that the track followed by the aircraft over the ground is not necessarily the same as the direction in which the aircraft is pointing in the air.

#### **6.3.2. Drift**

If there is no wind blowing, the direction in which the aircraft is pointing in the air will exactly match the track over the ground. But this is not a realistic situation; there is always some wind blowing and this affects the aircraft's ability to track exactly where it wants to go. For example, if the aircraft wants to track due north and there is a westerly wind blowing, it would be blown off track. The amount by which it is blown off track is known as **DRIFT**. Before going any further, two points must be made :-

The aircraft's direction in the air is always referred to in terms of the direction it is pointing **TOWARDS**.

The wind direction is always referred to in terms of the direction it is blowing **FROM**.

If you think about it a bit further, it will be apparent that there will be no drift if the aircraft is flying either directly into wind or directly down-wind.

#### **6.3.3. Heading**

Finally, the direction in which the aircraft is pointing in the air (which we now know is not necessarily the same as the track it is following over the ground) is known as the **HEADING**.

### **6.4. AIRSPEED AND GROUND SPEED**

The speed of an aircraft through the air is known rather obviously as its **AIRSPEED**. There is no particular mystery about this, except that the indication on the airspeed indicator is somewhat affected by air density and for that reason there is an increasing error in the airspeed indication as the aircraft climbs to higher altitudes where the air is

less dense. However, for the purposes of this exercise in basic navigation, such density errors will be ignored.

If there is no wind, the speed of the aircraft over the ground will be exactly the same as its speed through the air. Combined with the fact that there is no drift in such circumstances, navigation is very easy - the aircraft goes where it is pointed and gets there at a predictable rate of progress.

Life gets more complicated when the wind starts blowing. If the wind is blowing in exactly the same direction as the aircraft is pointing, in other words we have a tailwind, the speed over the ground will be higher than the speed through the air. There will be no drift (track will be the same as heading), just a **HIGHER GROUND SPEED**.

Conversely, if the wind is blowing in exactly the opposite direction to the aircraft's heading, once more track and heading are the same but this time we have a **LOWER GROUND SPEED**.

### 6.5. THE TRIANGLE OF VELOCITIES

Let's bring all these points together in a diagram. The standard way of expressing in pictorial form the way in which the wind affects direction and speed of a glider is a diagram known as the **TRIANGLE OF VELOCITIES**. Note that the term "velocity" is quite specific; it means a combination of speed and direction.

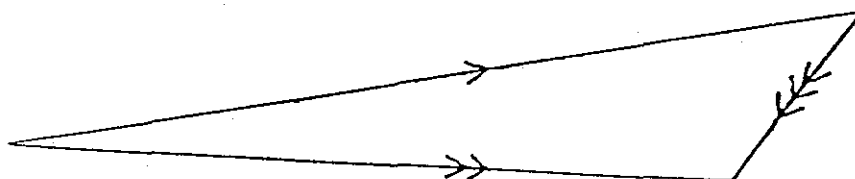

In the triangle of velocities diagram, note the following points : -

1. Aircraft heading, represented by one arrowhead. Anticipated distance travelled represented by the length of the line.
2. Aircraft track, represented by two arrowheads. Actual achieved distance after being affected by the wind is represented by the length of the line.
3. Wind velocity, three arrowheads.

Remember once again that the wind is always measured by the direction it is blowing **FROM**. It is very easy to get confused. Something else to confuse you is the fact that the wind velocity line on the diagram is in fact a **VECTOR**, which means that, as well as the line representing the direction from which the wind is blowing, the length of the line represents the actual strength of the wind. The longer the line, the stronger the wind. This will have an obvious effect on the drift, which is exactly what the diagram is meant to convey.

Referring back to the diagram, you will see that a cross-wind affects ground-speed as well as drift. A wind blowing at 45 degrees onto the nose of the aircraft will have the obvious effect of drifting it off to one side, but it will also have the less obvious effect of slowing it down. The diagram shows clearly that the track line is shortened, which means that the aircraft has slowed down and will not make the expected distance in the time originally planned. Try drawing a few triangles of velocities with the wind coming from various directions at different strengths and you will see the infinite variety of results which come out of the exercise.

## 6.6. CORRECTING FOR DRIFT

It is all very well to realise that the aircraft will experience drift when exposed to a crosswind. What we really need to do is work out how to correct the situation. It is not difficult to do - all that is necessary is to determine how much drift is occurring and change the aircraft's heading to compensate. If the aircraft is drifting 10 degrees to the right of its required track, an alteration of heading by 10 degrees to the left will compensate. However, this will only work if the pilot either knows beforehand that this amount of drift will occur or is astute enough to recognise instantly in flight that the aircraft is experiencing this drift angle. If the aircraft is allowed to drift some distance off track, a great deal more compensation will have to be made than the bare 10 degrees used as an example here.

It is possible to work out very accurately the amount of drift compensation necessary. The calculations involved in such an exercise can be performed on a Navigational Computer, a device owned by almost all power pilots and by very few glider pilots. Accurate track-keeping is neither possible nor desirable in gliders, for reasons related to the need to follow thermals, but flying a powered sailplane engine-on is a different proposition and a good understanding of the basic principles of navigation is necessary.

## 6.7. USE OF THE COMPASS

Any powered sailplane used for cross-country flying should carry a magnetic compass. It is the most basic of all navigational instruments and is very simple to use. There are just a few fundamental principles which need to be known.

Divisions of the compass. The compass is divided up into 360 degrees, which may be shown as the actual number of degrees (clockwise from North and back to North again) or possibly by named divisions (NE, SW, NNW, etc). Conventional aviation practice is to use the number of degrees clockwise from North. For example, a north-easterly track would be described as 045 degrees, south-westerly as 225 degrees.

Magnetic North. The needle of a compass does not point to True North, that is the North Pole on the ordinary geographical map. It points to an entirely different place on the surface of the earth, a point known as Magnetic North. It does not really matter exactly where Magnetic North is (as a matter of interest it is somewhere between Canada and Greenland), as long as we know that there is a difference between the two Norths. This difference is known as VARIATION. The actual value of variation at any given point on the earth's surface, in number of degrees, is shown on a WAC chart by the purple dashed lines known as ISOGONALS.



Let us imagine that you look at your map before a cross-country flight and you see that the variation in the area of your intended track lines is, say, 10 degrees East. This means that there is 10 degrees of difference between the isogonals and the grid lines in that part of the world. If you try to get to the point you have marked on your map without taking this variation into account, you will go astray.

The pilot must add or subtract the variation to the chosen heading to fly on the compass. But how does he know whether to add or subtract? Fortunately a little jingle comes to our assistance here. If the variation is west, the pilot will add the variation to the compass reading. This results in the magnetic heading being greater than the true heading. The opposite is the case for easterly variation.

<p>VARIATION WEST, MAGNETIC BEST. VARIATION EAST, MAGNETIC LEAST</p>
--

### **6.8. WHAT IF YOU GET LOST?**

Every pilot gets lost at least once. Some pilots make more of a habit of it than others. It is impossible to cover all contingencies in a book such as this, so a short check-list of recommended actions is offered:

**DON'T PANIC.** Realisation that you are lost is an unpleasant feeling, but it's not the end of the world.

If you have been using the compass for basic track-keeping, go back to it and establish the last heading you were flying to maintain the track you wanted. Keep flying that heading until you find something that you can identify.

If, in spite of all your efforts, you are still well and truly lost, it is best to land as soon as you can in the safest available landing area. This means that a conscious decision must be made to stop worrying about your whereabouts and concentrate on a safe landing. There will probably be someone on the ground who will be delighted to tell you where you are.

If you have a radio on board, when you realise that you are lost, **TELL SOMEONE.** There is plenty of help available and many pilots have been steered back to an area they recognise by talking to other pilots in the air or on the ground.

After you have landed and have located a telephone, make contact with your base as a matter of first priority. This is of paramount importance, because the people back at base will be compelled to take Search and Rescue (SAR) action on your behalf if they hear nothing from you.

## USEFUL TIPS TO PREVENT GETTING LOST

1. Never go cross-country without the relevant maps.
2. Always read from the map to the ground, never from the ground to the map. Although the latter technique can be made to work for some of the time, it has the unfortunate side-effect of convincing you that the feature you are trying to identify is the one you want to see, not the one that it really is. Once this has occurred, getting lost is a virtual certainty. Much better to pick out the features from the map (silo, road/river intersection, etc) and search for them on the ground. Its just as easy to do and works every time.
3. In summer, the sun tracks from due east to due west. In winter it tracks from north-east to north-west.
4. Fence lines usually run north-south and east-west.

## **7. HAZARDOUS WEATHER**

### **7.1 GENERAL**

Cross-country power pilots, whether general aviation or ultralight, will be familiar with the hazards associated with continuing a flight into deteriorating weather such as lowering cloud-base or worsening visibility, leading to loss of horizon reference and possibly contact with rising terrain.

Glider pilots will probably never have experienced a problem with deteriorating weather, apart from the odd thunderstorm which may have blocked their track on a cross-country flight and which forced either a diversion or an outlanding. Gliders need soarable conditions to stay airborne and the kind of conditions which cause poor visibility and promote low cloud around hills would normally see a glider firmly on the ground long before the weather became a hazard.

Powered sailplanes are a different matter. Some of them have 100 knot engine-on cruising speeds and a 500 NM (1,000 km) range. They can cross complete weather systems without the need to soar and they can do so legally with a pilot in charge who holds a GFA pilot certificate and who has never been trained in the discipline of turning back in the face of, for example, a lowering cloud-base.

The combination of a lowering cloud-base and rising terrain is the worst kind of deteriorating weather that a VFR pilot can encounter. When a pilot first enters this kind of weather, it may not be apparent that any kind of hazard is developing. The cloudbase is lowering, but so what, the ground is still in sight and it looks like it's still safe to keep going. Unfortunately the ground is rising and the pilot is too focused on keeping clear of cloud to detect that the ground is slowly coming up to meet him.

A close second to being trapped under a lowering cloud-base, or maybe of equal danger to a pilot, is flying above 8/8 cloud, with no holes through which a safe descent can be made. Gliders sometimes get caught by these conditions when wave-flying and there are horror stories from New Zealand of visiting pilots not realising the hazards and getting caught this way. By the time they have found a hole and descended through it, some of these pilots have found themselves several kilometres out to sea. None have been actually lost at sea yet, but the message is clear - stay on the ball and don't get caught without an escape route.

The advent of GPS as an accurate position-finding aid does not change this advice. Although it might tell you your position with great accuracy and thereby assist in keeping you clear of high ground, it is no better than you are at predicting the cloudbase in the area you are attempting your descent.

### **7.2. OROGRAPHIC CLOUD**

The conditions described above are usually orographic (orography = the branch of geography associated with mountains). If a moist wind meets hills or mountains, it is forced upwards and the moisture in the air condenses into visible water droplets, i.e. cloud. This cloud will often develop when there is no cloud elsewhere in the sky.

It is very tempting for a pilot to follow a valley into the mountains, hoping to find a way through, only to find that the valley ends in a mountain face that climbs straight up into cloud. There is no way through, not enough room to turn around and go back, and nowhere to land safely. The trap has closed and another fatal accident has become inevitable. This kind of thing happens regularly to power pilots and exactly the same thing can easily happen to pilots of powered sailplanes.

If there is a good side to the formation of orographic cloud, it is the fact that it is so predictable. It happens regularly all along the eastern seaboard from northern Queensland right round the south-eastern corner of Australia into western Victoria. Air blowing from the sea or associated with frontal conditions directs a moist airstream into the rising ground of the dividing range, resulting in conditions which are perfect for the formation of orographic cloud. These conditions must be avoided like the plague if a pilot is not to be "suckered in" in the way that so many pilots do every year. It should also be mentioned that the dividing range is not by any means the only place where these conditions may be encountered. In principle, they can occur in any place where the ingredients (wind + moisture + rising ground) are present.

Following an endless valley is a certain way to get trapped in these conditions, but it is not the only way. Having an engine, it seems the easiest thing in the world to climb above the orographic cloud, cross the ranges and descend on the other side. This is the second trap mentioned in the first section of this chapter.

If orographic cloud forms, for example, on the windward side of a range of hills just inland from the coast with an onshore wind blowing, it will often be drier on the other side of the ranges. The air is partially dried out during the process of being forced upward and giving out some of its moisture to form cloud.

This may mean that the cloudbase is higher on the leeward side, or it could even result there being no cloud at all on that side. But how do you know? You don't of course, because you don't know how moist the air was in the first place, you don't know how much drying took place on the ascent and you don't know what's on the other side. Making a descent through cloud without knowing whether there is sufficient clearance under the cloud is foolhardy indeed. Nobody with any instinct of self-preservation would even consider it.

There's one more trick that these conditions have up their sleeve. Air blowing up a slope will give good lift, known logically enough as slope lift or ridge lift. This can usefully augment the climb rate of a powered sailplane when operating near hills in clear air. But if there is moisture about, it can also immerse you in cloud more quickly than you thought possible. Worse, if you are approaching a line of hills from the lee (downwind) side and you think you can see a way through by flying between the top of the ridge and the cloud-base (the dreaded "letter-box"), you will find that the downwash of air as you approach the ridge-line may completely nullify your climb-rate and may even result in the machine descending at full throttle. If you have committed yourself to crossing the ridge and have left no escape route, this is just another way of becoming a statistic. There are plenty of these on record, too.

All things considered, trying your luck in orographic conditions truly is a mug's game. There are plenty of dead pilots of powered aircraft who will attest to this fact when

you meet them one day. It takes strong discipline to make a decision to turn back when you might otherwise have been tempted to try to find a way through. External pressure from a passenger, or self-imposed pressure from a need to meet a deadline that evening, are notorious factors in persuading a pilot to attempt a task which has all the hallmarks of being impossible.

The ability to use the engine to move around independent of soaring conditions brings with it a need for pilots to recognize and acknowledge deteriorating conditions and to have the self-discipline to turn around and make a safe landing while it is still possible.

The best way for the pilot of a powered sailplane or a power-assisted sailplane to avoid weather-related trouble is to remember the following advice -

**NEVER FLY A POWERED SAILPLANE OR POWER-ASSISTED  
SAILPLANE ANYWHERE YOU WOULD NOT FLY A GLIDER**

### **7.3. FOG**

This is another phenomenon to which glider pilots will have had little or no exposure. Fog can occur in one of two ways, viz.

#### **7.3.1. Radiation fog**

This kind of fog occurs when long-wave radiation escapes into the upper atmosphere, usually during a clear evening or night. The escape of this radiation results in rapid cooling of the ground, which in turn cools the lower level of the air below its dew point and the air condenses into fog. Suitable conditions for the formation of this fog are a cool temperature, with some moisture in the air and a light wind. Note that a light wind is more likely to produce fog than no wind, because a light wind causes just enough mixing to spread the cooling effect through a fairly thick layer. Most inland fogs are radiation fogs.

Although the risk of getting caught by radiation fog is small for a powered sailplane pilot, it could occur if a flight is running later than anticipated and arrival takes place just on last light, provided the foregoing conditions are met.

#### **7.3.2. Advection fog**

Advection means the horizontal movement of air, a kind of horizontal convection. Advection fog occurs when moist air moves over a cool surface, cooling the air below its dew point and resulting in the formation of fog. Sea fog is advection fog, formed when moist air moves over the cool surface of the sea.

A pilot returning to a destination near a lake (e.g. Canberra) may expect advection fog over and near the lake if the right conditions are present.

Whatever kind of fog is encountered and however low the risk of meeting any kind of fog at all, it remains a silent enemy which traps pilots by denying them their horizon

reference at the most critical part of the flight. There is no point in getting caught by it if you know how to avoid it.

#### 7.4. THUNDERSTORMS

These are obviously hazardous. Severe turbulence, extreme up and downdraughts, hail and lightning can all be deadly to an aircraft which gets caught under or near the edge of a thunderstorm. This is especially true in the tropics, where the vertical extent of such storms gives them a violence which can easily tear a glider apart.

There is one hazard associated with thunderstorms which may not be obvious. This is the "downburst" phenomenon (sometimes referred to as "microburst"), a rapidly descending tongue of cold air emanating from the edge of a fully-developed storm. Apart from the extreme rates of descent which exist in such downbursts, they have a dramatic effect on surface winds when they arrive on the ground. They can make their presence felt up to 8km from the edge of a large storm, in a position where a glider pilot could believe himself to be safe from serious effects of the storm. An aircraft trying to outrun the storm and make a precautionary outlanding would be seriously hazarded by the downburst and it may be impossible to control the glider in the extremely strong and turbulent wind near the ground.

The motto is - avoid large storms, not by a small margin of 2km or so - give them a very wide berth indeed. There are forces at work well outside the immediate vicinity of these storms and those forces are invisible to the eye.

#### The three stages of thunderstorm development

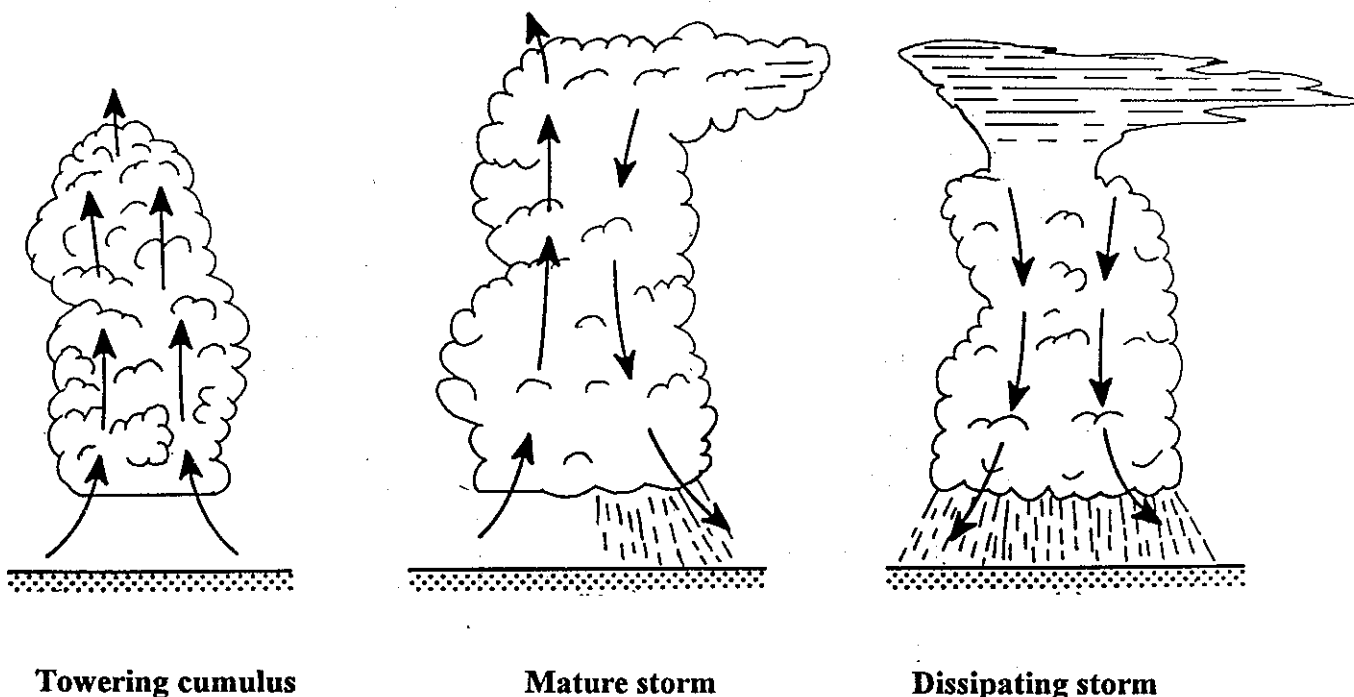

**Towering cumulus**

**Mature storm**

**Dissipating storm**

## Microburst

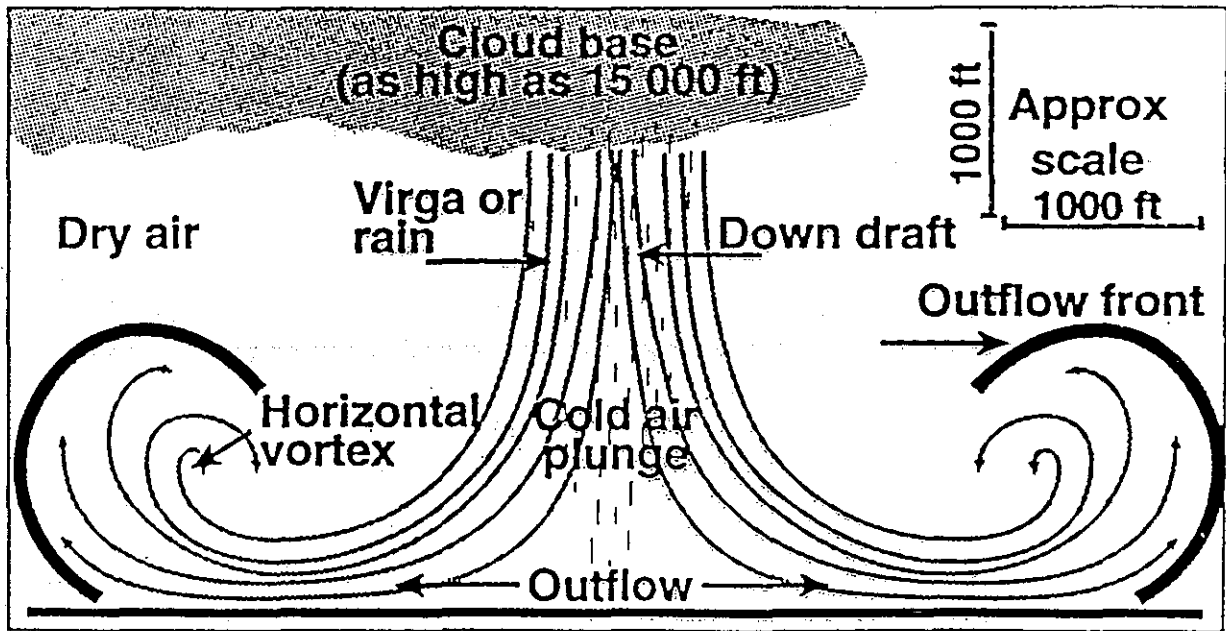

Note: "Virga" is rain which dries out before it reaches the ground.

## 8. OTHER HAZARDS

### 8.1. UNLANDABLE TERRAIN

Crossing unlandable terrain is another tempting hazard for the pilot cruising a powered sailplane or power-assisted sailplane under engine power. Remembering that some of the engines fitted to these machines are not certificated designs, it makes no sense to place yourself at unnecessary risk by getting out of reach of landable terrain when you wouldn't even consider doing so in a pure sailplane.

The pilots most at risk from this kind of hazard are those who become seduced by an apparent level of reliability demonstrated by their engines. To these pilots, the sudden silence comes as a distinct shock, to the extent that their ability to think straight and take charge of the emergency is impaired. Thus we have a below-par pilot faced with the task of finding the least-unlandable piece of ground and hoping that he/she will be able to get the machine on the ground without injury or worse. To be fair, this phenomenon is not confined to powered sailplane pilots - there are plenty of power pilots who cheerfully pressed on over bad country in a single-engined aircraft and have never been seen alive again.

### 8.2. INSUFFICIENT TERRAIN CLEARANCE

This is defined as flying over terrain which may have landable areas available to a glider flying at a reasonable height, but the pilot has eroded all the height margins and eliminated all chances of reaching one of these areas if an engine failure should occur.

The reason for eroding height margins is usually related to deteriorating weather. This may be weather that is not bad enough to create an accident known in aviation as a "controlled collision with terrain", in other words the cloud meeting the ground, but is bad enough to cut out all chances of finding somewhere to land if an engine failure occurs. The remedy is obvious.

### 8.3. INTENTIONAL LOW FLYING

The presence of an engine sometimes has a most unfortunate effect on pilots and makes them want to behave like cowboys. There is at least one fatal accident on record in which a powered sailplane contacted a powerline while being deliberately flown at very low level. It is one of the least excusable types of accident and the remedy is again obvious.

The answer to all the hazards listed above is the same as the answer to weather-related accidents and is worth repeating -

**NEVER FLY A POWERED SAILPLANE OR POWER-ASSISTED  
SAILPLANE ANYWHERE YOU WOULD NOT FLY A GLIDER**



## 9. INSTRUCTING IN POWERED SAILPLANES

A few tips, not covered elsewhere in this manual.

### 9.1. TAKEOFF EMERGENCIES

#### 9.1.1. Aborted take off

Take-offs may be aborted for a number of reasons -

(a) Failure to become airborne by a predicted separation point. This emphasises the need for instructors to know the take-off performance of the powered sailplane, and the effect on that performance of factors like long grass, soft ground, upslope, downwind component or ambient temperature.

(b) Complete or partial failure of the engine on the ground run. Complete failure on the take off run leaves the pilot with no alternative but to abort. Partial engine failure leaves the pilot with a decision to make - to continue or to abort. On the assumption that the aircraft will not have achieved its predicted separation point (otherwise it would be airborne), the throttle should be closed and the takeoff aborted. There is no case for continuing the take-off run with an ailing engine in the hope that the aircraft will become airborne before the boundary fence.

(c) Loss of control on ground run. For whatever reason (long grass catching in outriggers, excessive crosswind, mishandling), loss of control on the ground run demands an aborted take-off. Even if the machine does eventually leave the ground in apparent safety, it can quite easily be so far off line that it may collide with obstacles well outside the normal take-off path. Better to abort the take-off than to tempt fate.

#### 9.1.2. Engine failure during climb out

Engine failures can occur for a number of reasons; mechanical failure, fuel starvation or fuel exhaustion are the most common. Whatever the reason, if the failure is complete the powered sailplane is in a situation similar to a glider on aerotow which experiences a rope break or failure of the tug engine. The comparison is not completely apt because the powered sailplane pilot will have the opportunity to choose exactly the take off flight path most appropriate to the conditions, whereas on aerotow the glider pilot is at the mercy of the tug pilot. In any case, the action following complete engine failure is very nearly the same as for a glider suffering a rope break or tug failure, with the obvious exception that it is not necessary to pull the release. The first priority is to establish the "safe speed near the ground" (Minimum 1.5Vs), then choose further action to be taken in accordance with the height and position of the powered sailplane in relation to the take-off strip. (Note: glider pilots will have no difficulty with this concept, but an aeroplane pilot coming to powered sailplanes will show a tendency to go straight ahead regardless of better options available. This is because he is unaccustomed to the flat glide angle of the powered sailplane in comparison with the machines he/she is used to.

Partial engine failures are more subtle. Without detailing all the possibilities here, the pilot must decide whether to rely on any small amount of power which may be left following a partial failure, whether to try to rectify the problem (it may, for example, be carburettor ice), or whether to shut the engine down completely and carry out a safe landing as a glider. In circumstances of partial engine failure, it is most important to give priority to keeping the aircraft under full control, and not be distracted by trying to coax a recalcitrant engine into life.

## **9.2. ENGINE OFF PERFORMANCE**

Typical two-seat powered sailplanes used for training, when flown with the engine and prop stopped, have sink rates and glide angles considerably worse than their closest equivalent pure sailplanes. The sink rate suffers because of the extra weight of the engine and its associated electrical and fuel system, as well as the fuel itself. The glide performance suffers because of the increased cross-sectional area of the engine installation, the propellor and the more complex undercarriage necessary to provide propellor clearance on the ground. Propellor drag may be minimised by feathering (mechanically twisting the prop blades to align with the airflow).

Whatever the glide performance, the fact remains that a powered sailplane has a higher sink rate than a pure sailplane and in the case of trainers this can often be a significant degradation. This is not surprising in view of the fact that the dead weight being carried by the machine easily amounts to that equivalent to an extra person, and a large person at that.

Remember that the pace at which an instructor needs to work is in inverse proportion to the performance of the glider. Many training powered sailplanes have very poor performance engine-off and this can cause significant workload problems.

## **9.3. CIRCUITS, APPROACHES AND LANDINGS**

This is the area where the powered sailplane is open to the greatest abuse. There are three reasons for this:

1. It is very easy to use the engine to solve problems which really ought to be solved by development pilot judgement.
2. Trying to get as many landings as you can into a particular session without regard for how the circuits relate to how a glider normally flies circuits.
3. Being tempted to land with the engine running, with a view to carrying out "touch and go's" to achieve the objective of doing as many landings as possible.

All three of these reasons have pitfalls.

The primary intention of training in powered sailplanes is to train pilots with a strong orientation towards soaring and the effort must be made to ensure that the powered sailplane is flown as much like a glider as possible. It is a glider with a self-launch facility. Circuits, approaches and landings should be carried out with this in mind.

Some guidelines can be laid down as follows.

### **9.3.1. Engine-off circuits and landings**

This emphasises the gliding purpose of the training and has the added benefit that everyone concerned with the operation is continually reminded that the machine is primarily a glider. Thus, powered aircraft integrating with the gliding operation regard it as just another glider and have no expectation that it will ever get out of their way. This is ultimately to the benefit of the gliding operation. From the student's point of view, use of the powered sailplane as a glider makes subsequent conversion to pure gliders easy and straightforward.

Propellor clearance on most two-seat powered sailplanes is very limited. Even slight mishandling of the landing by the student can cause the propellor to hit the ground, especially if a bit of pitching occurs during, for example, a bounced landing. This will splinter a propellor and possibly cause damage to the engine. The expense of a new propellor, possible damage to the engine and the loss of flying revenue more than overcome any imagined loss of efficiency in circuit training caused by landing engine-off.

The final nail in the coffin of engine-on landings is that the instructor may be tempted to rescue a mishandled landing by using power. This is generally not possible because we are not equipped with enough hands to cope with all the required actions. The right way to fix any mishandled glider landing is by a combination of attitude and airbrake control. Forget about the engine.

### **9.3.2. Joining the circuit in exactly the same way as a glider does**

The biggest sin is climbing the powered sailplane along the downwind leg. This is tempting, as it can speed up the circuit training process, but it is a highly dangerous practice because the powered sailplane will be climbing underneath gliders which are descending. Both types of machines will be in each other's blind spots, creating the dreaded "double blind" situation feared by all VFR pilots. Do all the climbing upwind of the field, cool the engine down, switch off and join the circuit normally.

### **9.3.3. Touch and go landings**

Another tempting way to try to speed up the training process. The hazards of landing engine-on have already been pointed out and it would be foolish to ignore them. However it is possible to carry out a touch and go from an approach with the engine stopped if the engine is reasonably warm and the powered sailplane has an electric starter. Do it if you must, but on balance it is not a recommended practice, especially at busy gliding fields and especially at a combined glider/power operation. The last thing a visiting pilot expects, if he/she sees a powered sailplane on finals with the prop stopped, is for the machine to do a touch and go. Much better to do a full stop landing, taxi back and take off again. This has the added benefit of reinforcing a pre-takeoff check before every flight, an invariable gliding practice which is not adhered to in the power-plane practice of touch-and-go landings.

The other problem with touch-and-go landings is that the separation point after power is applied is inevitably much further down the field than is the case in a normal take-off. This can severely compromise obstacle clearance after take-off and can just as easily place the powered sailplane in a non-maneuvring area for a considerable period of time. In this way, a strip which is adequately safe for normal operations becomes unsafe if touch-and-go landings are used.

In summary, circuit training in powered sailplanes demands a high degrees of discipline if the right emphasis is to be achieved. Techniques which might seem superficially convenient may prove counter-productive in the long term.

#### **9.4. CROSS-COUNTRY AND OUTLANDING TRAINING**

One of the most useful functions of a powered sailplane is cross-country training. Navigation, thermal centreing, height-band selection, etc, can all be done with equal effectiveness by a pure sailplane, but the ability to carry out several circuits and approaches into outlanding paddocks in any one flight is unique to the powered sailplane.

Note the intentional use of the term "circuit and approach" in this context, intentionally omitting any reference to the landing itself. Outlandings generally entail more risk than landings back at home base, the principle reason for this being lack of detailed knowledge of the paddock itself and in particular of its immediate surroundings. With the powered sailplane's ability to fly from paddock to paddock, it is tempting to land in any paddock which appears superficially suitable for training purposes, and it is very easy to get caught out by, for example, an undetected Single Wire Earth Return (SWER) power line. There are numerous cases of this kind of accident on record.

It is therefore recommended that approaches into outlanding paddocks be terminated at a break-off height suitable to (a) the characteristics of the paddock and its surrounds as assessed from circuit height, and (b) the instructional effectiveness of the exercise in terms of assessing whether the student would have successfully landed on the paddock. If you cannot tell at, say, 50ft AGL whether the techniques used during the circuit and approach would result in the landing being successful, it is questionable whether you are suited to the job of instructing in that particular role. The exception here is where a club has a number of regular paddocks for outlanding training which have been properly assessed, their surrounds and surface are known and the owner's permission obtained to actually land in them.

If dedicated paddocks for outlanding training are not available, the best way to use the powered sailplane in this role is to carry out a number of circuits and approaches as described, then check very carefully the student's approach and landing accuracy on the same flight on return to base. This takes advantage of the recency effect of having just done a few approaches into paddocks, while scrutinising very closely the accuracy of the pilot's technique in a risk-free environment.

## 9.5. SIMULATED LAUNCH EMERGENCIES

Powered sailplanes can adequately simulate the following emergency situations -

(a) Aerotow rope break. Because the climb-out pattern of an average two-seat powered sailplane is fairly similar to many aerotow combinations at about 400FPM, a reasonable simulation of an aerotow failure such as a rope break can be given by closing the throttle at varying heights during the climb-out. Like actual rope-break practices, they should be started high (about 1000ft) and worked downwards as confidence develops. Exactly the same principles apply as to gliders, priority being given to preserving adequate speed in order to conserve total energy. Instructors should beware of becoming "rope-break happy" with a powered sailplane, in the process ending up pointing back at the strip at all kinds of strange angles and positions and acquiring for themselves a reputation for possessing zero airmanship. Use the machine intelligently and it can provide quite sensible simulations of real emergencies.

(b) Winch/auto cable breaks. This is a more contrived exercise than the aerotow failure case and demands very careful setting up in order to be realistic and safe. It is not easy to establish a 45 degree climb angle in a powered sailplane without diving to a considerable speed before pulling up into a simulated winch/auto climb. Therefore the machine is first dived to a speed of about 80 knots and pulled up to about 45 degrees with the throttle being opened fully as the final climb angle is achieved. Then, with the climb at 45 degrees, when the speed falls to 55 knots indicated the throttle is closed to simulate the cable-break. This gives adequate training in the control movements and sensations experienced in the cable-break case, and is a very good introduction to the lag experienced in establishing a safe speed following the pitch-down manoeuvre. This is probably the limit of the usefulness of the powered sailplane in this exercise, because if the machine is used to teach the judgement of "what do I do with the height I have now", it becomes a nuisance to other users of the aerodrome, who have difficulty predicting what the machine is going to do next.

**GENERAL WARNING** Be very careful of low level emergency simulations. Powered sailplanes are generally not over-endowed with power and it is easy to get into a situation which is very difficult to get out of. This is especially true on summer days - remember density altitude and its effect on engine power output and wing and propellor efficiency. Do not go anywhere in a powered sailplane that you would not be prepared to go on an aerotow.

## 9.6. PARTICULAR TIPS FOR CONVERTING POWER PILOTS TO POWERED SAILPLANES

### 9.6.1. Use of lift and sink.

Power pilots are unlikely to be aware of using thermals (and avoiding sink) to augment climb-rate after take-off. Although circling in thermals with the engine at full-throttle causes considerable airmanship problems, the intelligent use of lift and sink in the climb-out pattern is a skill which will need to be taught to the power pilot.

### **9.6.2. Use of spoilers/airbrakes.**

The power pilot has been trained to use the elevator to control speed and the throttle to control rate of descent. This is similar to the gliding concept of using elevator to control speed and spoilers or airbrakes to control rate of descent. Where confusion sometimes sets in is if the instructor does not make it clear that the engine is NEVER used in a powered sailplane to make any adjustments to the descent rate. This point has already been made earlier but it is worth reinforcing here. It is essential that the engine is not used (and preferably should be stopped and feathered) during the approach, to drive home the message that the spoilers or airbrakes are the descent control and the approach is adjusted by their use in conjunction with the elevator, AND BY NO OTHER METHOD.

### **9.6.3. Use of aiming point.**

The power pilot may not be skilled in the use of an aiming point to establish a datum for approach control. Whereas a glider pilot converting to powered sailplanes will establish an overshoot situation on final approach before using spoilers/airbrakes, a power pilot may not realise the importance of this and may be quite happy to get into an undershoot situation with a view to relying on the engine to get himself out of it.

### **9.6.4. Coordinating between elevator and spoiler/airbrake.**

This is an acquired skill, whether it be to counter the nose-down pitch typical of spoilers or the more complex trim changes associated with use of airbrakes. It requires practice at height before being relied on to provide accurate control of the final approach path to touchdown.

### **9.6.5. Throttle creeping open.**

Many powered sailplanes have their throttle controls spring-loaded OPEN, for reasons of safety in the event of failure of part of the linkage. If the friction nut is not tight it is quite common for the throttle to creep open, which can go undetected on a power-on approach and makes it impossible to control the final approach path with the feeble spoilers fitted to some training types.

## 10. POWER-ASSISTED SAILPLANES

These are conventional sailplanes with the addition of a small engine for self-retrieve. It is a condition of the certification of a power-assisted sailplane (PAS) that the engine does not provide enough power to self-launch. The maximum climb rate permissible for certification of a PAS is 1 m/s (approximately 200 ft/min).

On the basis that these machines need an aerotow or winch/auto launch to get airborne, they are treated as gliders in Australia, although they may be treated as powered sailplanes in some other countries.

The treatment of power-assisted sailplanes as gliders is justified by the simple engine installation, which requires very little management. There is a simple engine control unit, incorporating an engine extension/retraction facility, ignition switch and coloured lights to indicate RPM. There is no throttle and the engine is pre-set to run at full power. The propeller blades fold automatically on retraction.

An example of a power-assisted sailplane Engine Control Unit (Discus bT) is shown.

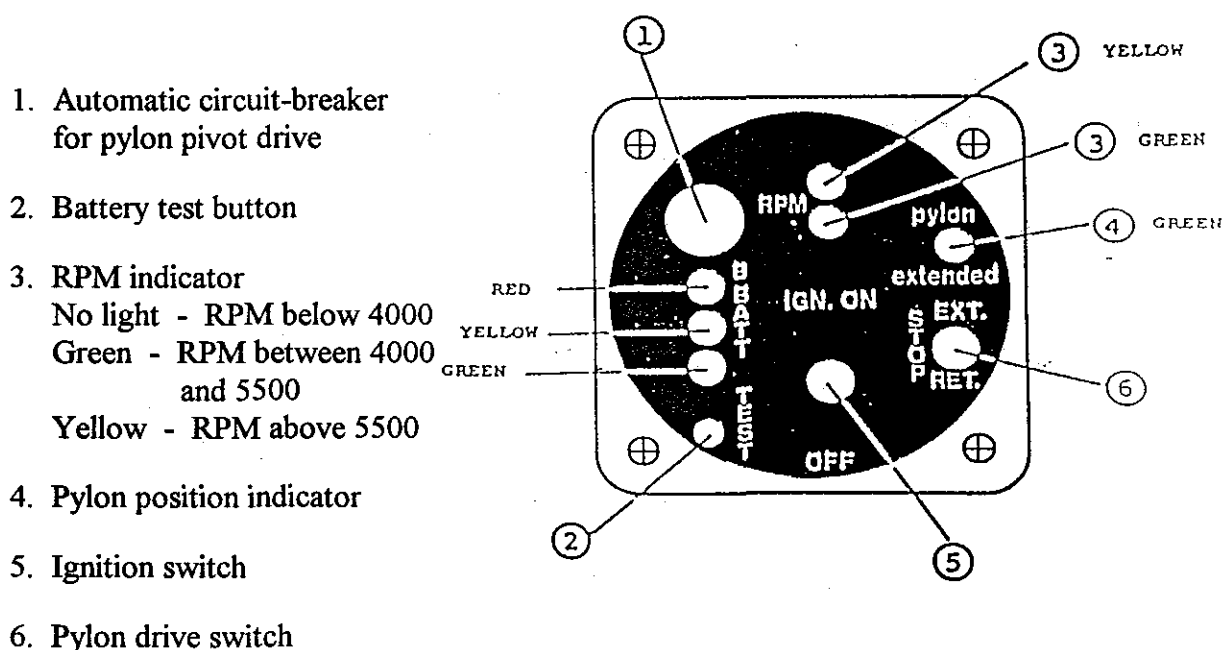

If the engine is extended but does not start, there is some loss of performance, but not as bad as a powered sailplane of similar layout. However, there is one trap for the unwary. If the engine is used to "save" a failed cross-country flight, there may not be enough power available to overcome strong sink. If a late decision is made to extend the engine, the situation could be even worse than in a powered sailplane. There have been accidents caused by pilots extending their "self-retrieve" engines rather late, only to find they could not out-climb or out-run strong sink and they struck the ground in the attempt.

## 11. TOWING GLIDERS WITH POWERED SAILPLANES

The following draft of a future European certification requirement to enable powered sailplanes to tow gliders is included to give an insight into the work required on new and existing powered sailplane designs to qualify them for this task. It is emphasised that it is only a draft and comes complete with underlinings, crossings-out and vertical marginal lines, which are the product of some of the European comment to date.

There is no particular timescale for the introduction of these requirements, but past experience with the European system suggests that it will be approximately three years from the date of the draft, through the NPA (Notice of Proposed Amendment) system and from there to final incorporation into JAR22.

NPA 22 - XX

18 February 1998

1. **Title** Towing of Sailplanes by Powered Sailplanes
2. **Sponsor** Lufffahrt - Bundesamt
3. **Introduction**

Powered sailplanes have been used for towing sailplanes for some time exclusively in one or two European Countries on a national basis. This situation now requires harmonisation in order to provide an equal basis for JAR-22 certification of these activities.

Recently the LBA, in view of the dramatically increasing demand from the operators and considering the slow JAA rule making progress, has been under pressure to provide an interim solution. So, after notification of with the European Union, technical standards were published for national certification, which are now proposed for formally amending JAR-22.

4. **Proposals**
  - 4.1 Add a new paragraph JAR 22.3 (d) as follows:
    - (d) Powered sailplanes may be used for towing sailplanes if they comply with Appendix K.
  - 4.2 Add a new Appendix K as follows:
 

See attached Appendix K.
5. **Justification**

The proposed amendment is intended to reflect the general level of safety as provided by towing of sailplanes by JAR-23 aircraft. Particular features, special to sailplane design and JAR-22 philosophy, have been considered, where necessary.



In particular:

JAR 22.207 (b): Emphasis is laid on an adequate stall warning perceptible to a pilot who may be distracted by the additional work load of towing.

JAR 22.1583 (k)(4): Recent policy in JAR-22 went to considerable efforts to prevent towplane upsets. The paragraph is in line with this philosophy.

JAR 22.1587 (c): Contrary to airplanes many sailplanes/powered sailplanes airfoil sections are sensitive to rain drops and dirt contamination. The paragraph is amended to reflect this situation for towing.

Note on cable retracting devices. The installation may require further specific provisions, e.g. the need for cable cutting devices. It is felt that this should be dealt with on a case by case basis.

#### **Economic aspect Safety assessment**

Operation of powered sailplanes for towing is expected to be less fuel consuming than that of JAR-23 aircraft and.—Therefore considerable interest has been reported to have it approved. The additional requirements were formulated to provide an equal level of safety as compared with towing operation of JAR-23 aircraft.

## JAR 22 Appendix K

### Towing of Sailplanes by Powered Sailplanes

For powered sailplanes used for towing sailplanes and for the powered sailplane - sailplane towing combination itself (hereafter referred to as the tow), the following requirements apply additionally:

Note: In the following the term "sailplane" is used for towed sailplanes as well as for towed powered sailplanes.

#### 1. Subpart B FLIGHT

1.1 IEM 22.21 applies to the tow and is amended by a new paragraph (4):

(4) For showing compliance with the requirements under Subpart B during towing of sailplanes by powered sailplanes, tests with at least three different representative sailplane types covering the whole permissible range of towed sailplanes should be conducted. During these tests, the maximum mass, aerodynamic characteristics, speed range and ground handling characteristics should be combined appropriately so as to obtain conservative results.

1.2 JAR 22.51 applies to the tow, 22-59 (b)(2) does not apply.

1.3 JAR 22.65 applies to the tow.

1.4 A new paragraph JAR 22.77 is added:

#### JAR 22.77 TOWING SPEEDS

The minimum towing speed and the best rate-of-climb towing speed must be determined by flight test.

The minimum towing speed must not be less than  $1.3 V_{S1}$  of the powered sailplane.

1.5 JAR 22.143 applies to the tow with "and slips" deleted in paragraph [a].

1.6 JAR 22.151 (c) and (d) applies to the tow.

1.7 JAR 22.207 (b) is amended to read:

[b) An artificial stall warning giving a clear and distinctive indication must be provided for the powered sailplane. The artificial stall warning may be waived if the stall warning is sufficiently clear and distinctive for the pilot, even under the additional work load when towing.

1.8 JAR. 22.207 (d) does not apply to the towing powered sailplane.

## 2. Subpart C - STRUCTURE

2.1 JAR 22.307 applies to the tow.

2.2 JAR 22-581 is amended to read:

(a) It must be assumed that the tow initially

is in stabilised level flight and that a towing cable load of 50 daN (in the absence of a more rational analysis) acts at the towing hook in the following directions:

(1) rearwards in the direction of the fuselage longitudinal axis;

(2) in the plane of symmetry rearwards and downwards at an angle of  $20^{\circ}$  to the fuselage longitudinal axis;

(3) in the plane of symmetry rearwards and upwards at an angle of  $40^{\circ}$  to the fuselage longitudinal axis; and

(4) rearwards and sidewards at an angle of  $30^{\circ}$  to the fuselage longitudinal axis.

(b) It must be assumed that the tow is initially subjected to the same conditions as specified in JAR 22.581 (a) and the cable load due to surging suddenly increases to  $1.0 Q_{nom}$

Note: It is assumed that only textile towing cables are used.

(1) The resulting cable load increment must be balanced by linear and rotational inertia forces. These additional loads must be superimposed on those arising from the conditions of JAR 22.581 (a).

(2)  $Q_{nom}$  is the rated ultimate strength of the weak links to be used for the sailplanes towed.

2.3 JAR 22-585 is amended to read:

### JAR 22.585 Strength of the Towing Hook Attachment

The towing hook attachment must be designed to carry a limit load of  $1.5 Q_{nom}$  as defined in JAR 22-581 (b) acting in the directions specified in JAR 22.581.

## 3. Subpart D - DESIGN AND CONSTRUCTION

3.1 JAR 22.689 applies also for the tow release system of the powered sailplane.

- 3.2 JAR 22.711 applies also for the powered sailplane and is amended by adding paragraphs (h) and (i):

(h) Release mechanisms for towing sailplanes must be installed so that there is no interference between the tow rope and any control surface with the towed sailplane in any position as defined in JAR 22.581 (a) and the surfaces being operated through their full angular movement.

(i) The release mechanism of the powered sailplane must be suitably protected against fouling.

- 3.3 JAR 22.713 (c) applies also to the release mechanism of the powered sailplane.

- 3.4 JAR 22.780 is amended by adding the following requirement:

Towing cable release and throttle must be located and arranged to be capable of operation by the same hand.

- 3.5 A Note is added:

The requirements in Appendix K do not constitute all the requirements necessary to cover the installation of cable retracting devices. Compliance with further requirements may become be-come necessary.

#### 4. Subpart E - POWERPLANT INSTALLATION

- 4.1 A new paragraph JAR 22.991 is added:

##### JAR 22.991 Fuel Pumps

- (a) If for the purpose of JAR 22.951a fuel pump is required for proper engine operation, an emergency pump must be provided to ~~immediately—~~ The supply for the emergency pump must be independent of the power supply for the main pump.
- (b) If both the normal pump and the emergency pump operate continuously, a means or a procedure must be provided to indicate failure of either pump.
- (c) The operation of any fuel pump may not affect the engine operation so as to create a hazard regardless of the engine power setting or the functioning of the other fuel pump.

- 4.2 JAR 22.1047 must be applied to the tow.

#### 5. Subpart F, EQUIPMENT

- 5.1 JAR 22.1305 [e] is amended to read:

(e) a cylinder head temperature indicator.

5.2 JAR 22.1307 is amended by adding the following sentence:

An easily removable rear view mirror of sufficient strength and rigidity must be attached and so located the pilot when seated with the seatbelts fastened, has full and unobstructed view of the towed sailplane in any position as defined in JAR 22.581 (a). It must be possible to permanently observe the towed sailplane without the accomplishment of other tasks being affected and without major turning movement of the head.

### **Subpart G - OPERATING LIMITATIONS AND INFORMATION**

Note: This information should normally be furnished under Section 9 of the Flight Manual.

6.1 JAR 22.1529 applies to powered sailplanes equipped for aerotowing.

6.2 JAR 22.1583 applies to powered sailplanes equipped for aerotowing, amended by the following paragraph (k):

(k) Towing of sailplanes by powered sailplanes

The following information concerning towing of sailplanes must be furnished:

- (1) Maximum weight of the powered sailplane (if differing from the value under (b) (1))
- (2) Maximum weight of the sailplane towed
- (3) Minimum limit for the allowable maximum aerotow speed of the towed sailplane ( $V_T$ )
- (4) Statement that only the sailplane nose hook must be used for the tow.
- (5) Information that the powered sailplane shall lift off only after lift-off of the towed sailplane
- (6) Maximum permissible nominal strength for the weak link or towing cable.

6.3 As far as applicable, JAR 22.1585 must be applied to the tow. In addition, the minimum towing speed and the best-rate-of-climb speed for the tow must be furnished. Furthermore, sailplane types whose relevant characteristics are comparable to those of the types used in the flight tests must be furnished as examples.

6.4 JAR 22-1587 (a) must be applied to the tow and is amended by the following requirements:

**In addition, information about the degradation of performance in take-off distance due to long grass, rain drops or contamination of the wing (leading edge) must be furnished.**