

www.gruppofalchi.com

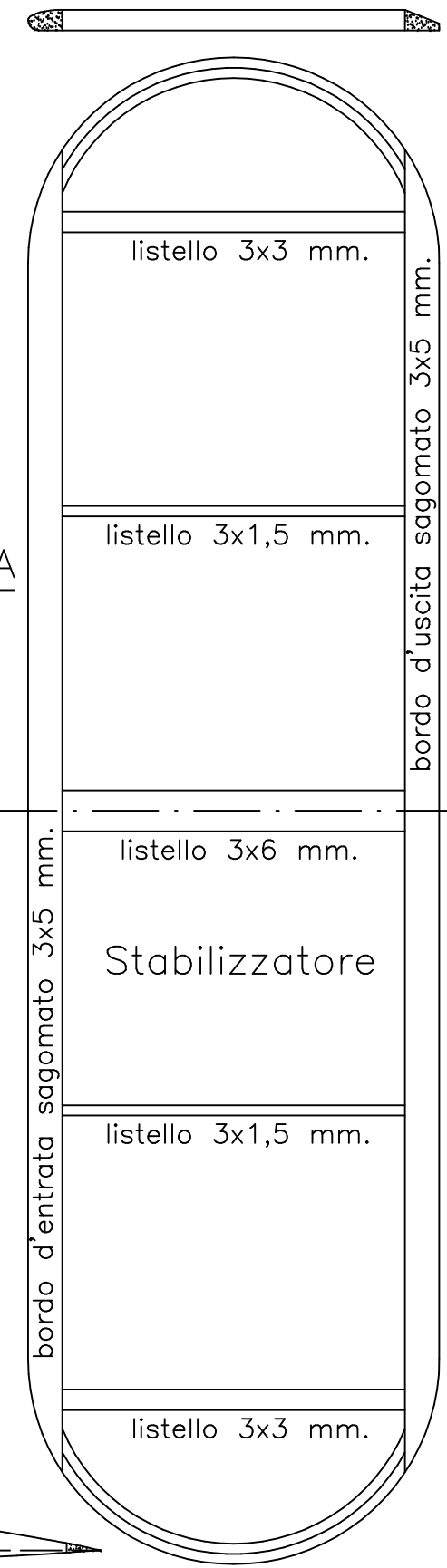
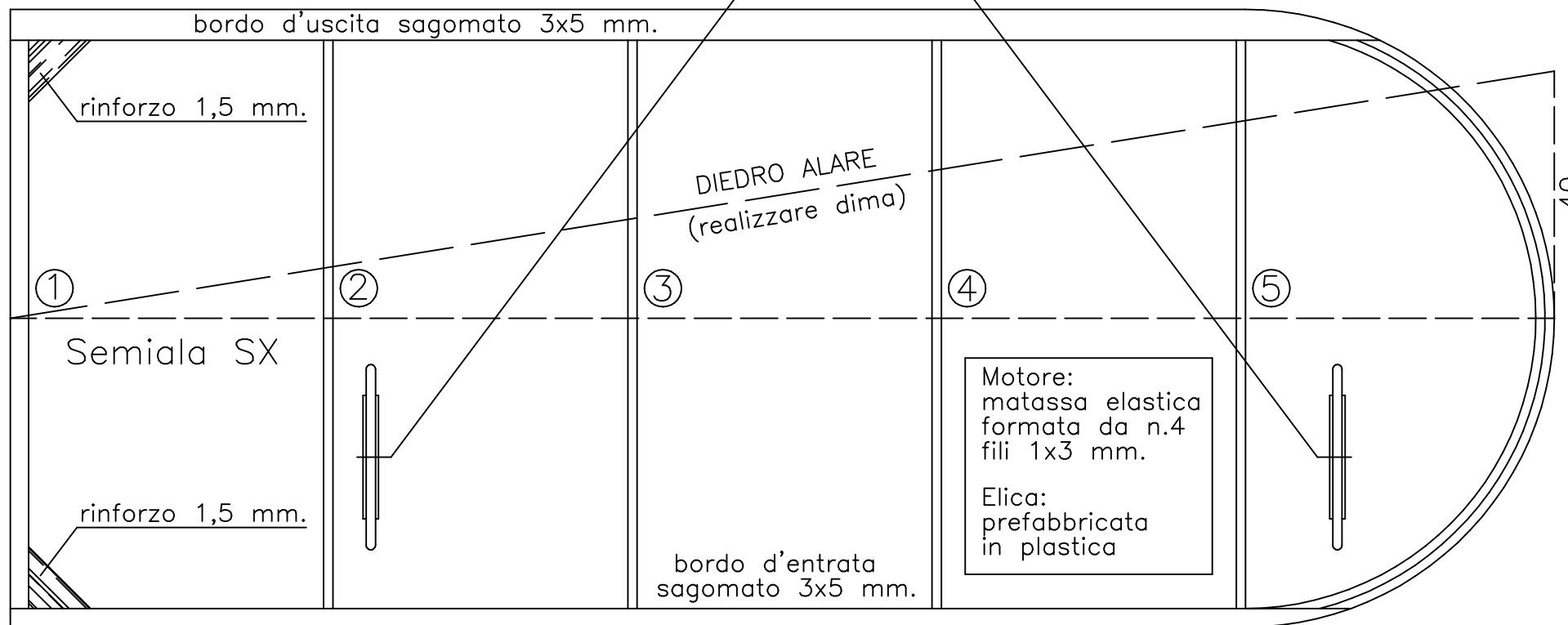

Sezione A_A

Terminali alari e stabilizzatore:
2 listelli 3x1,5 mm. sagomati, piegati su dima di cartone e incollati fra loro.

Ricopertura velature:
carta modelspan leggera incollata con pritt_stick o simili

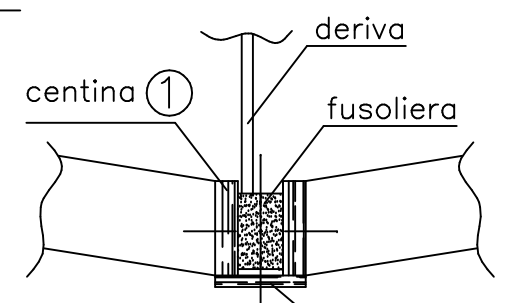
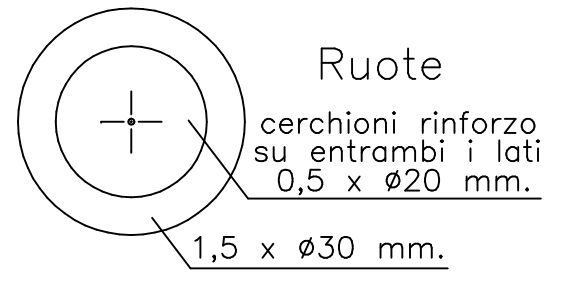

Sezione B_B

