

DISEGNI

TRITTICI

AEROMODELLI D.G.

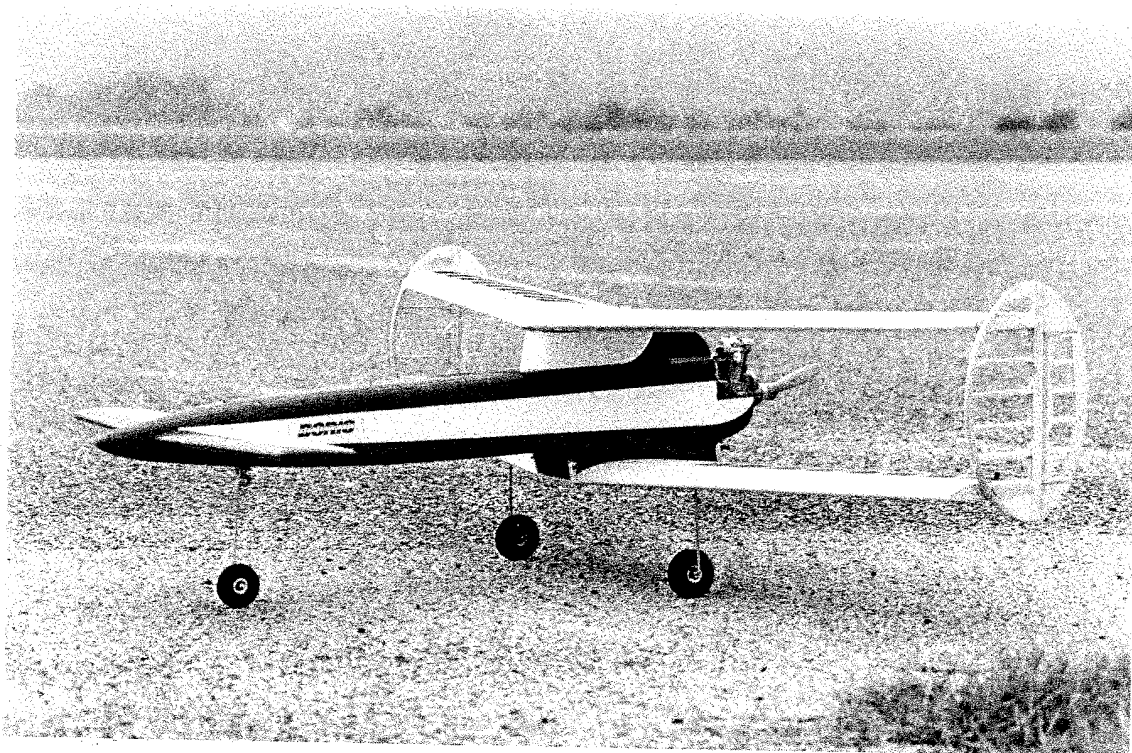

DORIO GIULIO 1936 · 1999

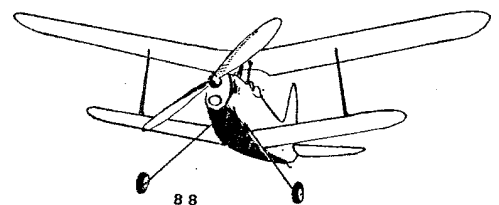
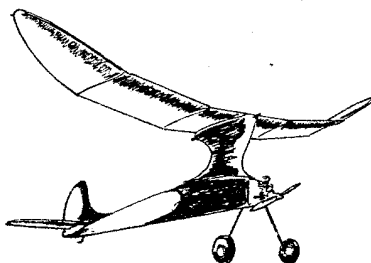
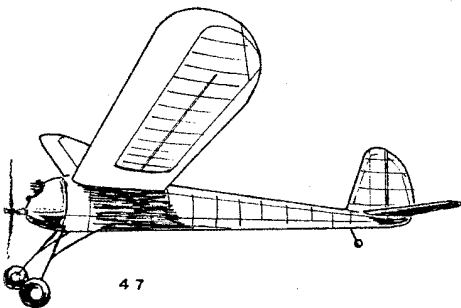
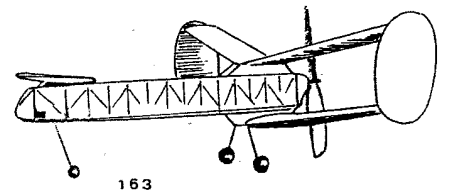
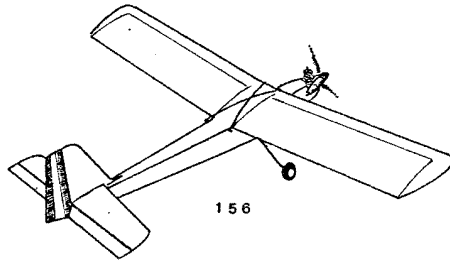
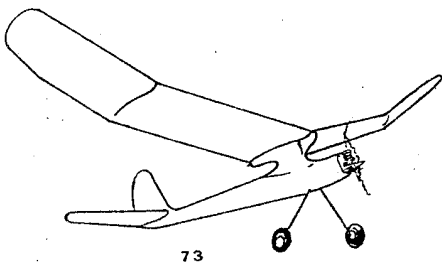
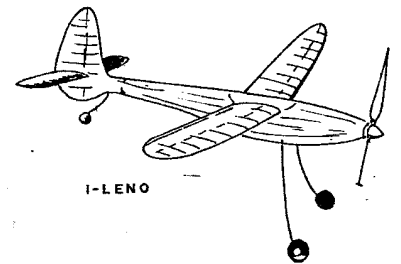
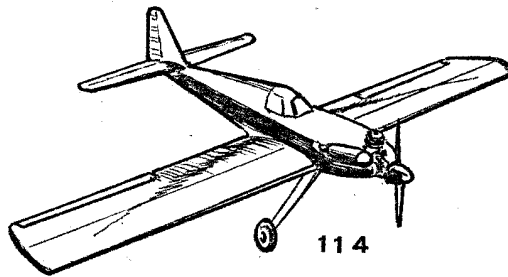
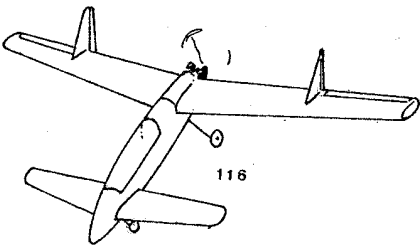
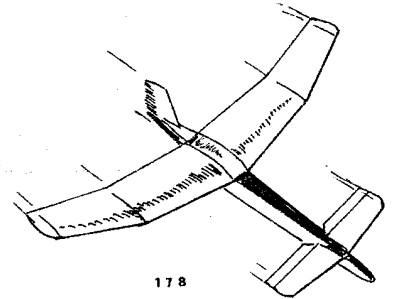
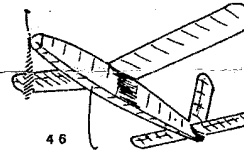
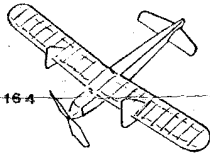
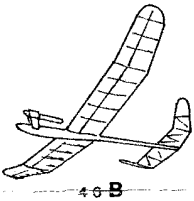
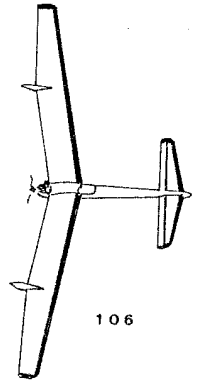
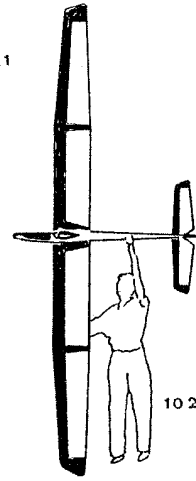
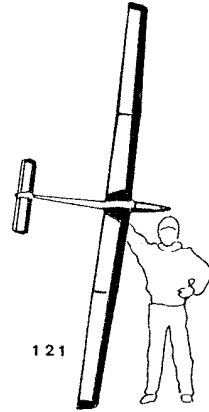
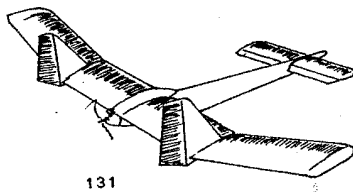
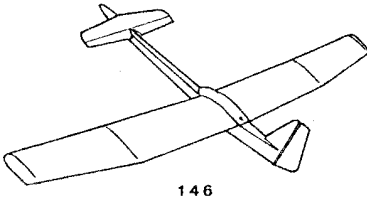
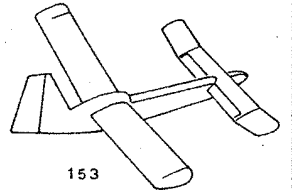
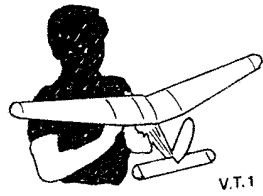
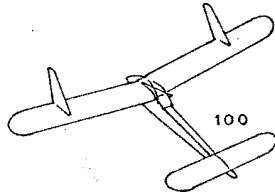
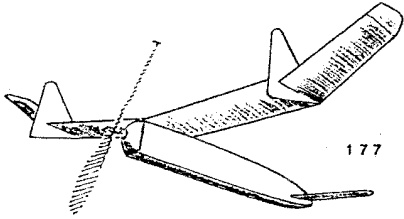
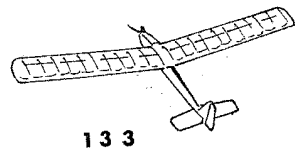
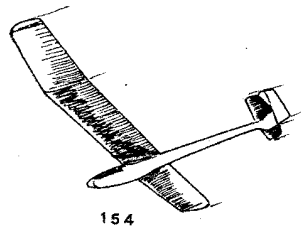
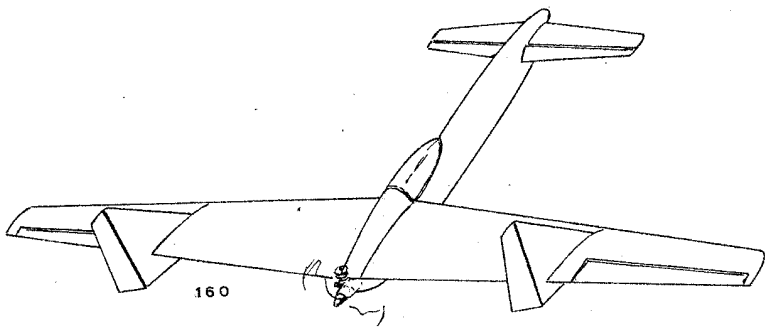

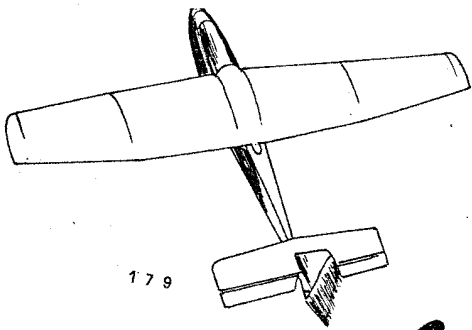

179

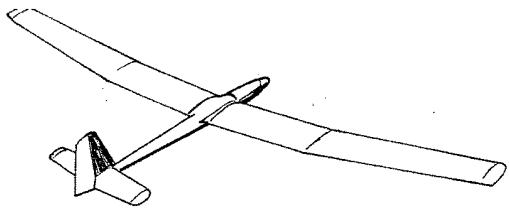

181

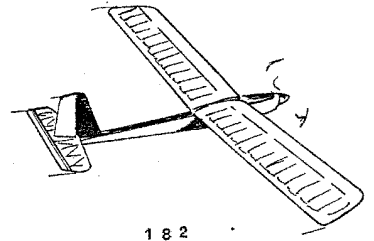

182

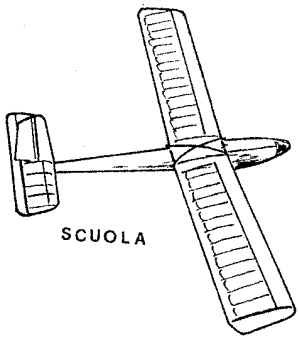

SCUOLA

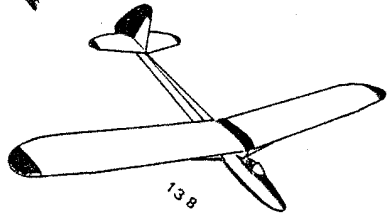

138

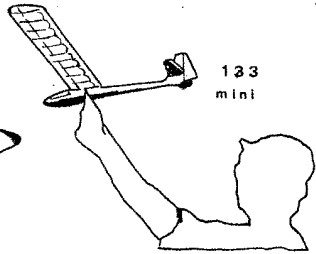

133
mini



140

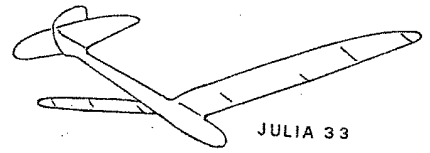

JULIA 33

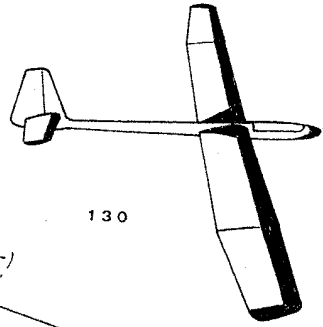

130

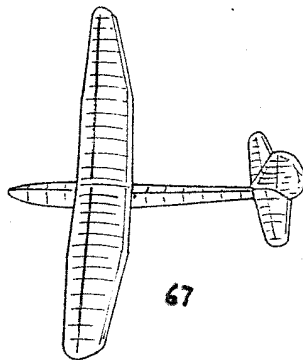

67

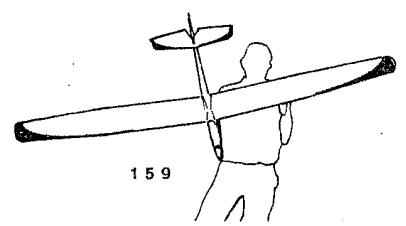

159

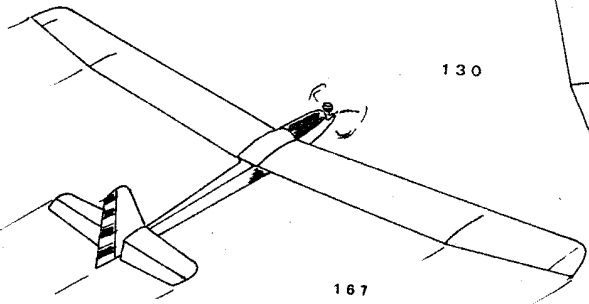

167

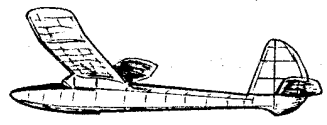

42

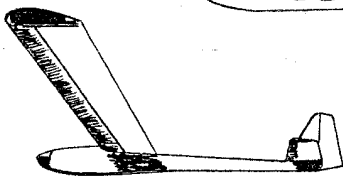

133

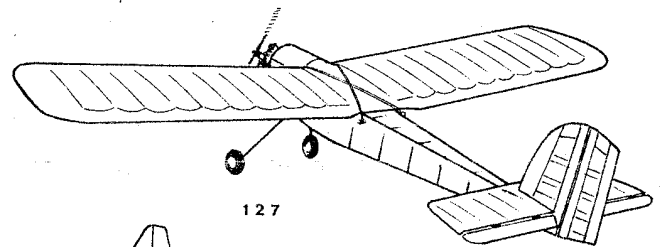

127

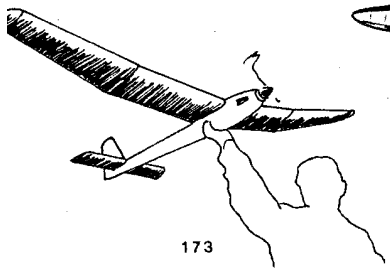

173

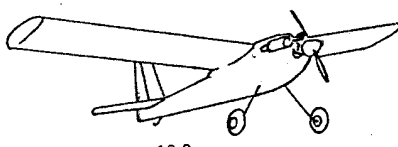

168

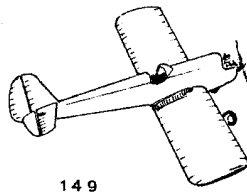

149

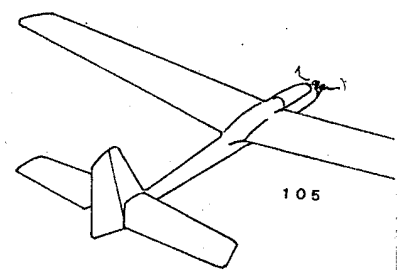

105

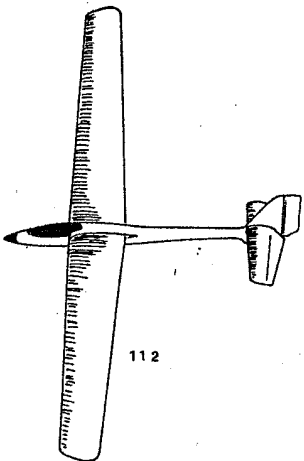

112

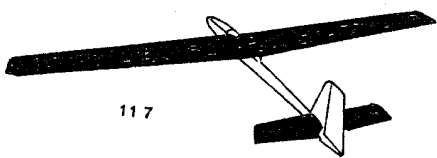

117

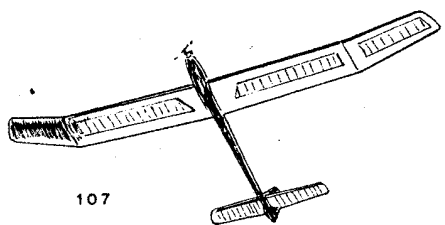

107

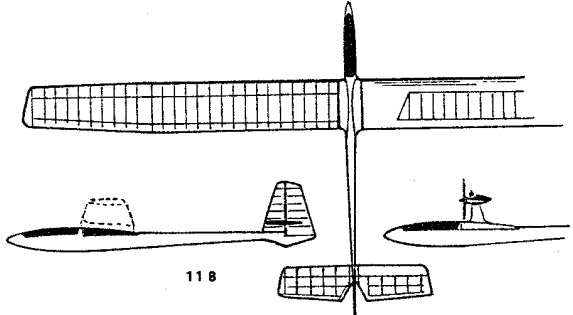

118

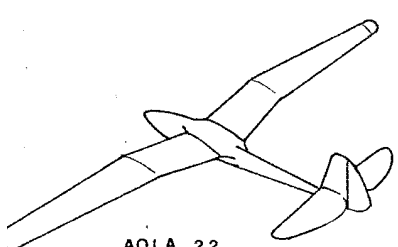

AOLA 22

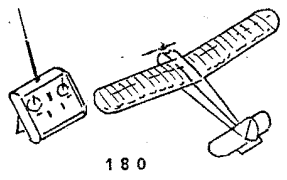

180

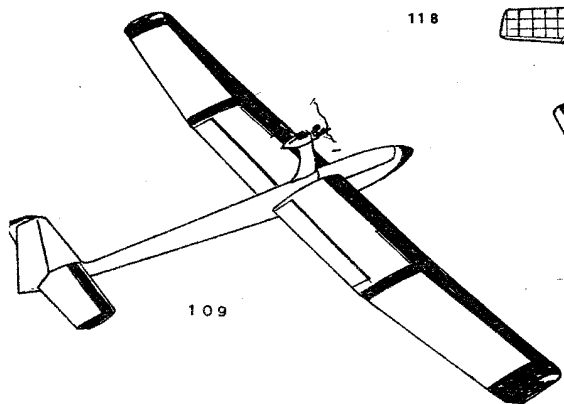

109

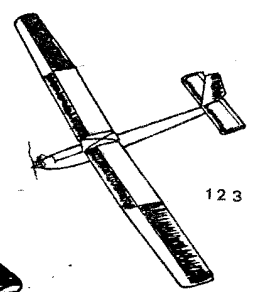

123

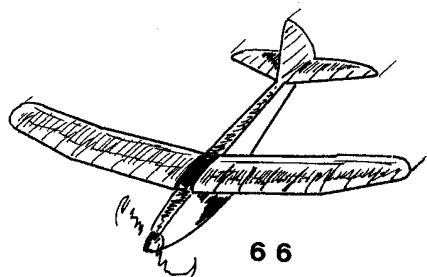
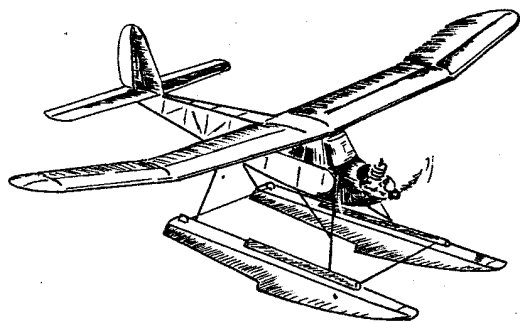
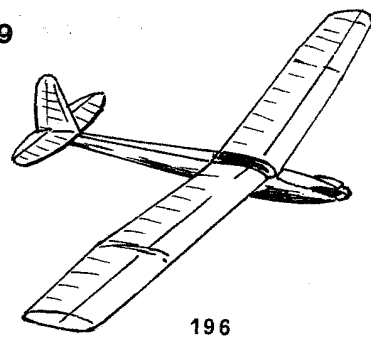
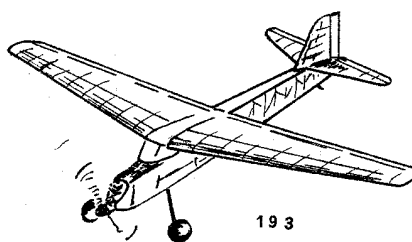
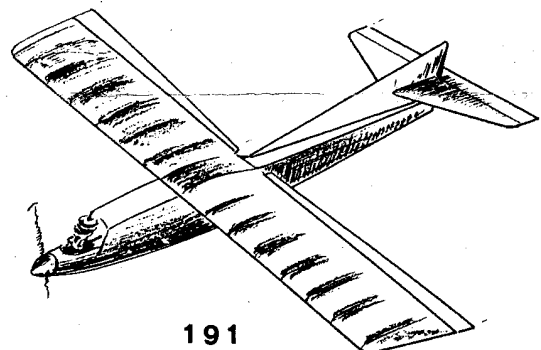
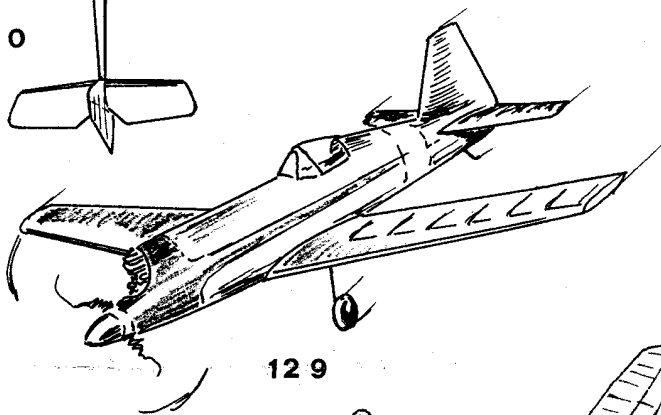
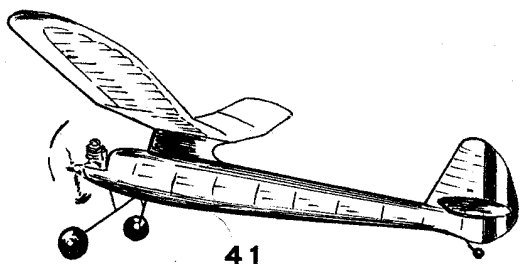
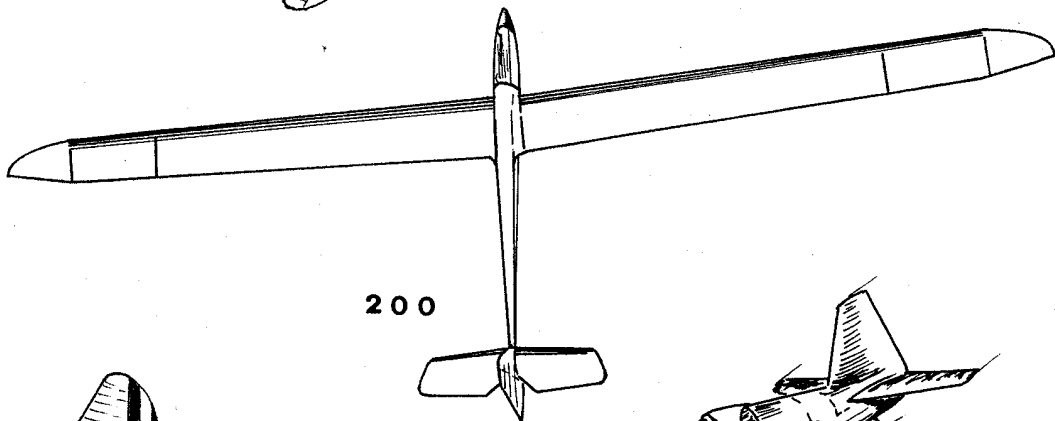
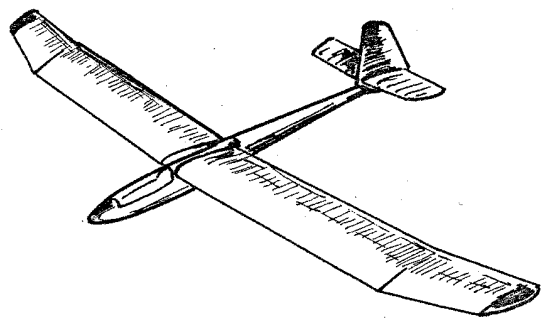
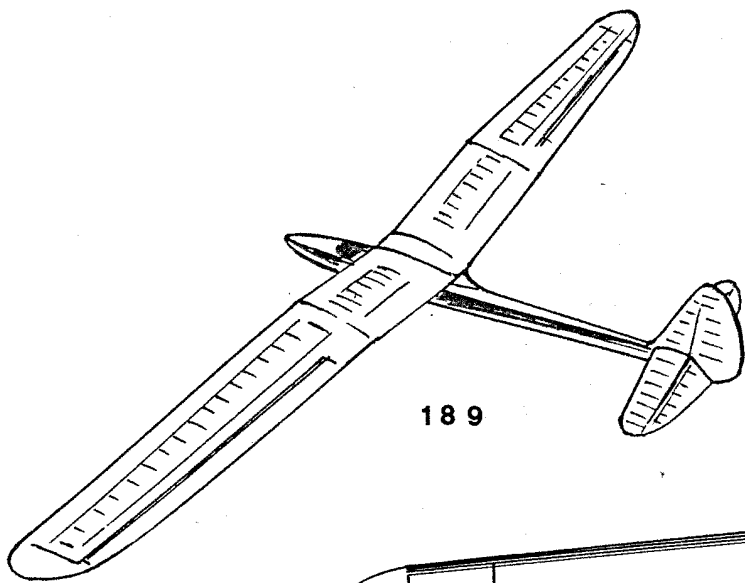

100	•					•	1100	-	-			•	216	331				
102	•	•					4160	3,5	2			•		295				
105		•					2200	2,5	3			•		244				
110							2200	-	-			•						
106		•				•	2620	1,8	3			•	217	331				
107		•					3080	1,8	2			•						
109		•					2880	1,8	4			•	211					
112	•						2700	-	2			•	226					
116			•			•	1950	10	4			•	477	331				
117	•						2150	-	4			•	250		251			
118		•					2800	1,8	2			•			231			
121	•						2960	-	2			•	260					
123	•	•					2000	1,5	2			•	255		237			
127			•				970	1,5	2			•	265					3
129			•				1060	1,8	2			•						
130	•						3130	-	2			•	278		260			
131		•				•	2200	1,8	3			•	272	331	281			
133	•					•	760	-	-			•	266					
133	•						1520	-	2			•	266					
138	•						2800	-	2			•	306					
140	•						2700	-	2			•	274		254			
146	•	•				•	2410	-	2			•	283	331	263			
E 146		•				•	2620	600	3		•	•						
149			•				1130	1,5	2			•			272			
153	•					•	800	-	-			•	295		284			
154	•						2880	-	2			•	310					
156			•				1280	3,5	3			•	314					
159	•						2280	-	2			•	331					
160		•				•	2200	3,5	4			•	332					
163				•	•	•	840	-	-	•		•	318					
164				•	•	•	490	-	-			•	320					
167		•					2040	1,8	3			•	328					
168			•				1140	1,8	3			•	362					
173		•					2000	600	3		•	•	370					
177				•	•	•	1260	-	-			•	412					
178	•					•	1000	-	2			•		EX 5		9	9	
179	•					•	1000	-	2			•		EX 5		9	9	
180			•				670	0,20	2			•						15
181	•						3000	-	2			•	481					
182		•					1800	600	3		•	•						20
183			•				1460	3,5-4T	3			•	400					
185	•						2580	-	3			•	456					
189	•						3000	-	4			•	431					
SIGLA	VELEGGIATORE	MOTOVELEGGIATORE	MOTOMODELLO	A ELASTICO	CANARD	VOLO LIBERO	APERTURA ALARE	MOTORE C.C.	COMANDI RADIO	OLD TIMER	ELETTRICI	DISEGNI 1-1	TRITTICI	MODELLISTICA	FLUG	FLAPS	FLIGHT	MODELLISMO

41				2280	6,5-4T	3			492				
42	•			1530	-	2	•	•				28710	
46		•	•	1110	-	-	•	•					
47		•		2056	6,5-4T	3	•	•	347				
67	•		•	1740	-	-	•	•	335402		12		
73		•		1660	2,5	3	•	•	343				
88		•	•	700	1	-	•	•					
RAZZO e 46 B				•	1100	-	-	•	•				
SCUOLA				•	1660	-	-	•	•	268		247	
S. PHOENIX					1380	1,8	2		•	454			
I. AOLA 22				•	2400	-	2	•	•	378			
I. LENO					1250	-	-	•	•				
JULIA 33				•	3100	-	2	•	•				
V. T. 1				•	880	-	-	•	•	356			
PROFILI ALARI					-	-	-			252			
172		•		1650	6,5-4T	4			•				
66			•	800	-	-			•				
191		•		760	2	2		•	453				
200	•			3400	-	3		•	491				
193		•		1260	1	2		•					
196		•		1500	400	3		•					39
1/2 A. TEX.	47		•	1330	1	2		•	473				
	114		•	1500	65	4		•	483				

4

