

John Pond

Vintage Engines of Yesteryear

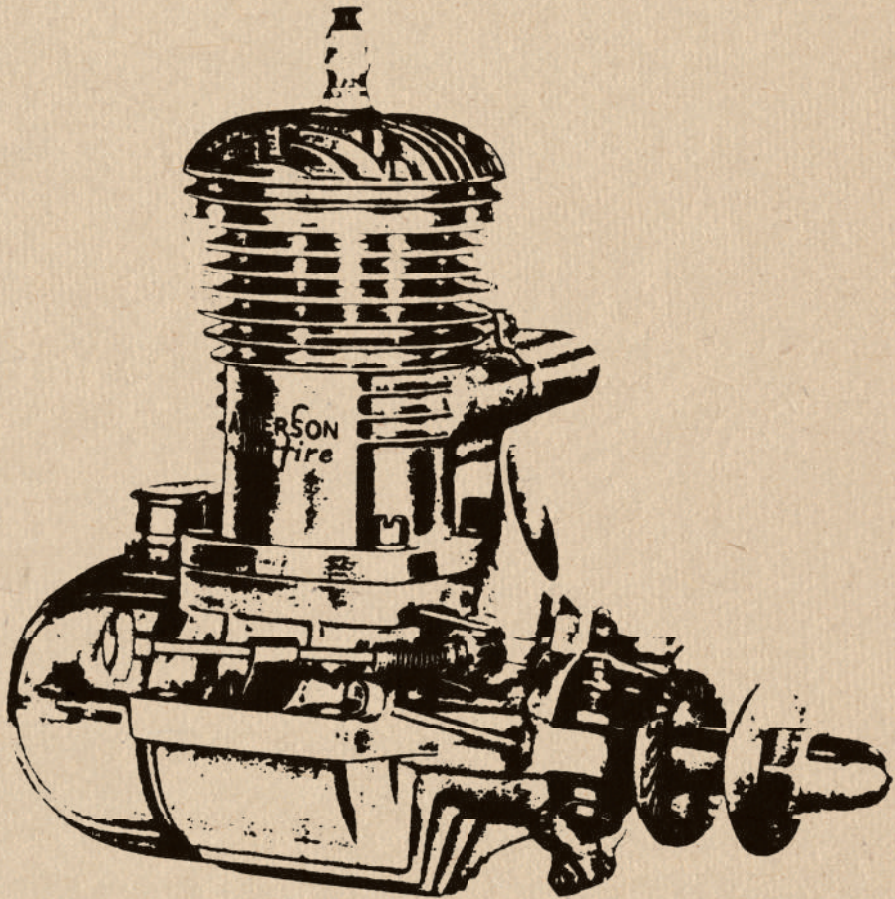

- Edizioni Modellismo -

Anderson Vivell Simplex Torpedo Brown Feeney OK Hornet Ball Syncro Elf

Thermite Madewell Bungay Ohlsson Gwin Supercraft Condor Micro Knight Tlush Little Dynamite Viking Bullet

VINTAGE ENGINES of YESTERYEAR

Cobey Waite Deezil Atwood Phantom Sky Charger Falcon Brat Luxor Golden Eagle Atom Husky Rogers McCoy Ken

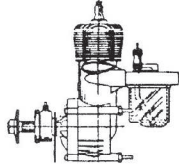
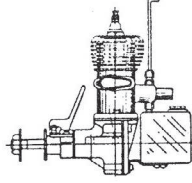
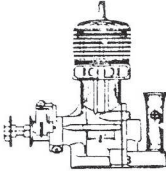

Vol. 1

Fleetwind Trojan Hetherington Delong Bunch Orwick Forster Molnar M&M

COVER AND DRAWINGS

ALLEN POND

COMPILED BY

JOHN POND

A VINTAGE PLANS OF YESTERYEAR
PUBLICATION

POND ASSOCIATES

PUBLISHED 1984

*** Nota alla ristampa ***

Dal 1973 al termine delle pubblicazioni, John Pond, uno dei massimi esperti di modelli d'epoca degli Stati Uniti, curò la rubrica "Plug Sparks" sulla rivista Model Builder. All'interno di questa rubrica c'era quasi sempre una scheda dedicata al "motore del mese". Tutti motori americani (o quasi) ovviamente, alcuni dei quali famosissimi (Brown Jr., Super Cyclone, Ohlsson .60, ecc.) ma molti praticamente sconosciuti alla maggioranza degli aeromodellisti. I trittici dei motori, quotati e con le dime di foratura per il castello, erano opera di Allen Pond e in alcuni casi non erano un capolavoro di precisione, ma avevano quel certo qual fascino artigianale introvabile nei precisi, ma freddi, disegni al CAD odierni.

Nel 1984 Pond decise di raccogliere le varie schede in due raccoglitori ad anelli che vendeva attraverso il suo "John Pond's Plan Service". Francamente non so quanti di questi volumi siano arrivati in Italia, ma in circolazione nel mondo oggi ce ne sono pochissimi e nelle rarissime aste su eBay spuntano cifre da capogiro. Per questa ragione, avendo la fortuna di possedere la raccolta originale completa, ho deciso di fonderla in un singolo volume e metterla a disposizione di collezionisti ed appassionati.

Come dicevo prima, la qualità d'impaginazione e stampa è molto artigianale e lontana dagli standard ai quali siamo abituati a lavorare noi, ma anche in questo sta il fascino dei "motori d'epoca dell'anno scorso".

Buona lettura.

(CdR, gennaio 2017)

PREFACE

If you have ever read the "Plug Sparks" article in the Model Builder Magazine, you probably have seen the engine drawings in the section entitled "Engine Of The Month". This ongoing series of vintage engines feature three-view drawings and a brief summary concerning the facts and figures of those particular engines.

The original intent was to publish these engines in full size views. However, this was not possible due to magazine considerations. This album is being offered to those engine collectors, modellers, and interested flyers who want an accurate size comparison of engines. These individual drawings are invaluable when making a direct comparison for fit in any given model.

Two albums are planned with 50 engines initially in each binder. As subsequent engine prints are made available, these will be sold as inserts tentatively priced at \$1.50 per drawing. This binder format will allow the owner to re-arrange the engine drawings as his interests desire.

ACKNOWLEDGMENT

The Pond Associates wish to acknowledge with thanks the Model Builder Magazine and William C. Northrop, Editor, for permission to reprint the enclosed engine material.

TABLE OF CONTENTS

BROWN JUNIOR.....	10
OHLSSON GOLD SEAL.....	12
BABY CYCLONE.....	14
OK 60.....	16
ORWICK 64.....	18
ATOM 09.....	20
DENNYMITE.....	22
MIGHTY MIDGET.....	24
ATWOOD CHAMP.....	26
SUPER CYCLONE.....	28
ROCKET.....	30
OHLSSON MINIATURE.....	32
MADEWELL 49.....	34
BANTAM 19.....	36
ARDEN 099.....	38
OHLSSON TWIN.....	40
SYNCHRO ACE.....	44
ELF SINGLE.....	46
HUSKY JUNIOR.....	48
FORSTER 99.....	50
ANDERSON SPITFIRE.....	52
OHLSSON 23.....	54
ELF 40.....	56
TROJAN JUNIOR.....	58
TIGER AERO.....	60
BROWN E.....	62
COMET 35.....	64
GOLDEN EAGLE.....	66
MEGON 199.....	68
OK 49.....	70
WASP TWIN.....	72
M & M 292.....	74
MARVIN JUNIOR A.....	76
LITTLE DYNAMITE.....	78
TORPEDO SPECIAL.....	80
FORSTER 29.....	82
BRAT.....	84
BULLET.....	86
EDCO SKY DEVIL.....	88
ORWICK 23.....	90
BLUESTREAK.....	92
HETHERINGTON METEOR 23.....	94
BATZLOFF 60.....	96

WALL TWIN.....	98
CONDOR KOPFER KING.....	102
HEATHERINGTON METEOR 49.....	104
BARKER 60.....	106
FERGUSON TWIN FALCON.....	108
CHUNN CHUM.....	110
SIMPLEX 25.....	112

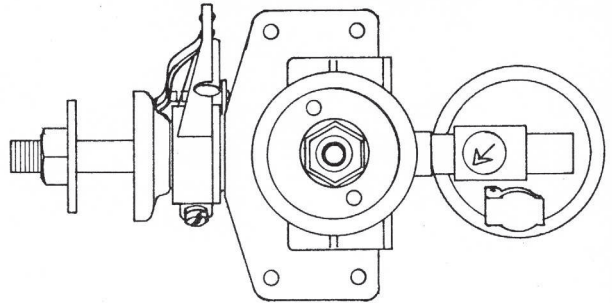
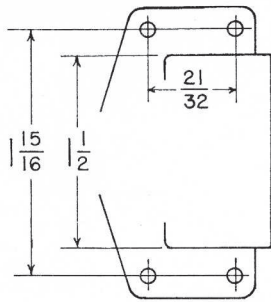

BROWN JUNIOR

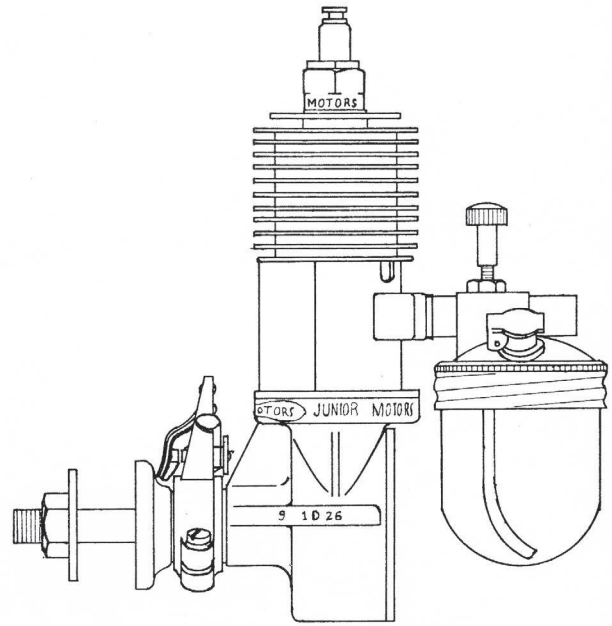
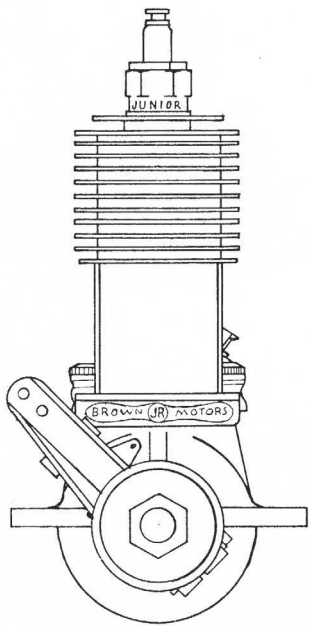

ENGINE THREE-VIEWS

As promised a long (?) time ago, we are going to run a monthly three-view of an old timer engine. Surprisingly enough, when Bob Von Kinsky suggested the idea and it was published, not too many answered. Lately, interest has picked up to the point that Tex Newman has volunteered to make drawings directly from the engines in his collection. Can't ask for more accuracy than that!

Naturally, the first engine to be featured would be none other than the famous Brown Jr. as designed by Bill Brown of Philadelphia. Between Brown and Maxwell Bassett, gas model flying was put on the map and launched a popularity that has been continued to this day.

The Brown Jr. enjoyed its greatest sales between 1936 and 1939. By 1939, the other manufacturers, notably Ohlsson, Atwood, and Bunch, had caught up and passed the Brown motor for power. Bill did attempt to come out with a Class B motor to compete with the Ohlsson 23, but the Brown E model (called "Brownie") failed to live up to expectations, and Bill had to fold up.

In later years Brown has been manufacturing little CO₂ motors that resemble their early big brother. These midget motors have been catching on as they allow use in models as small as Peanut scale. He has even produced a twin of .01 displacement! Talk about fly power!

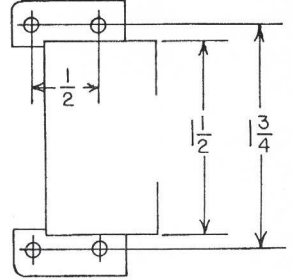
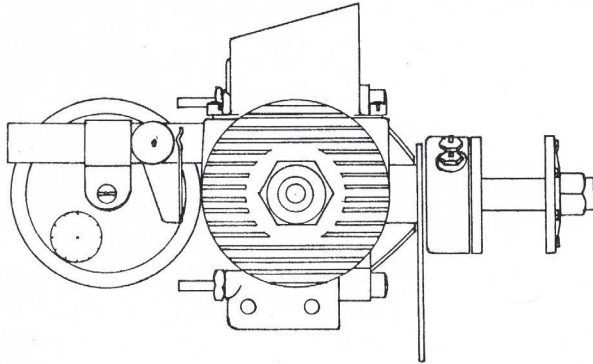

OHLSSON GOLD SEAL

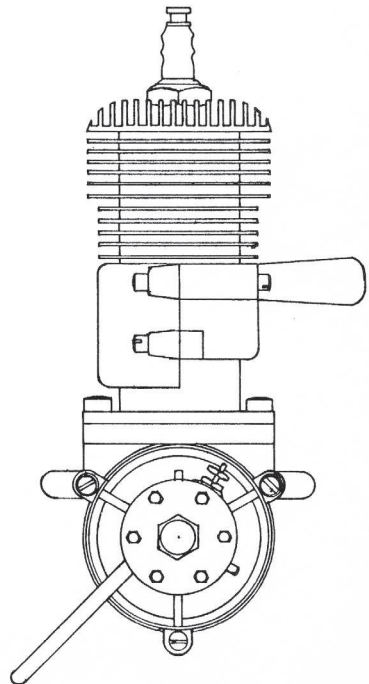
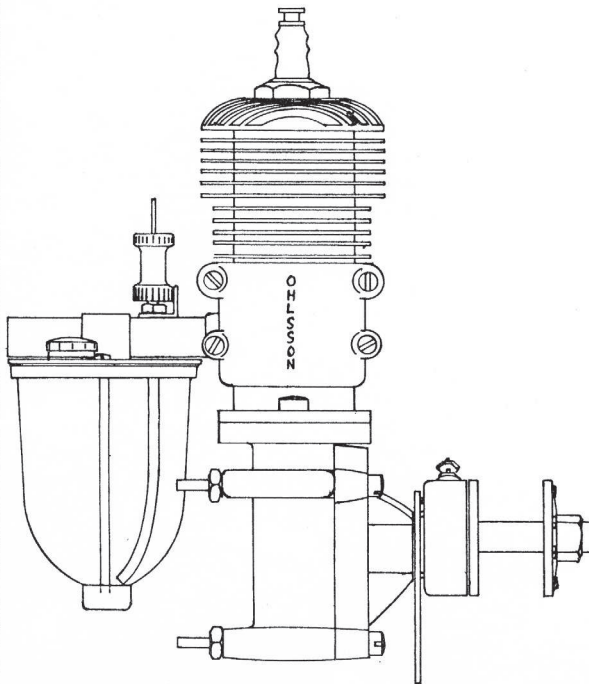

MOTOR OF THE MONTH

In line with the policy of presenting an engine three-view each month (drawn by Tex Newman) no self respecting engine collector would be found dead without an Ohlsson Gold Seal. This excellent engine, despite its large production, it still regarded as a rare engine.

In sketching a little history, it must be recalled that winning the California State Fair meet was regarded as the big contest in the West. Fortunes were made from engines that won the prestigious gas event. Bill Atwood won in 1935, and the Baby Cyclone was successfully launched. But that's another story we will feature next month.

Winning the California State Fair Gas Event eluded Irwin Ohlsson until 1937. When he finally won first place, he was awarded the Gold Seal, indicating first place. From this, the engine inherited its name, Ohlsson Gold Seal. The rest is history. Success after success followed Ohlsson and Rice until they were the largest engine manufacturer in the game. With the advent of the glow plug, the partnership was terminated and another great company faded from the scene.

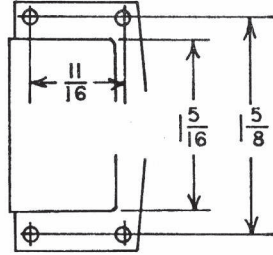
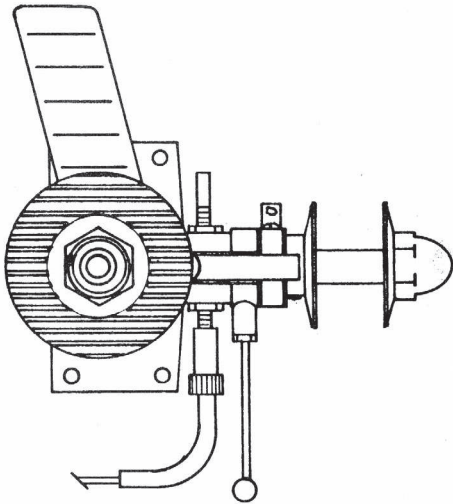

BABY CYCLONE

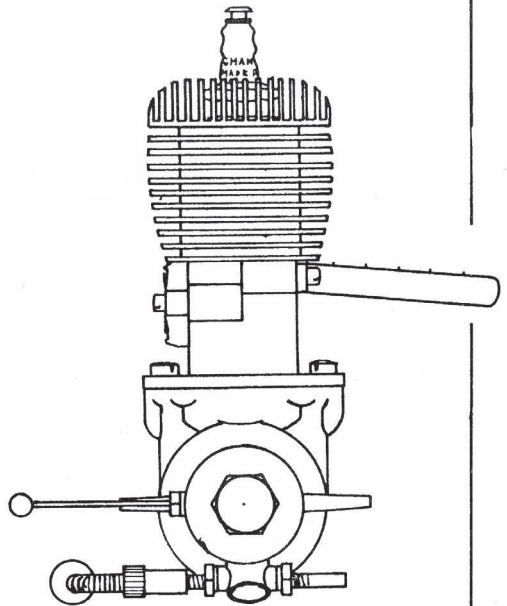
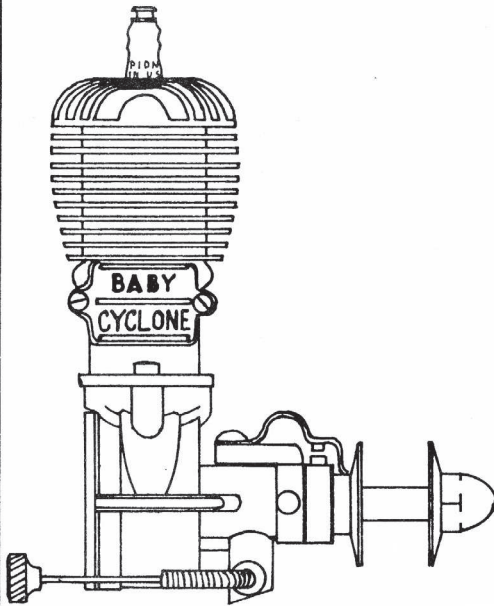

ENGINE OF THE MONTH

In line with presenting a three-view layout of an old engine to assist those to identify and plan for mounts, we like to carry a little background and possibly a few hints on the starting idiosyncracies of that particular engine.

Anyone worth his salt as an old timer will immediately recognize this month's 3-view as a Baby Cyclone, Model F. This was the last of the Baby Cyclones, as the Super Cyclone carried the designation Model G. Both engines were quite successful in their day.

The Baby Cyclone was popularized by Bill Atwood. There is some information that indicates that Mel Anderson was the original designer, but the point everyone misses is that Bill could develop any engine into a winning formula. Atwood was a tireless perfectionist and when he got through working a motor over, it was a going concern!

The Baby Cyclone was responsible for popularizing the gas engine craze as much if not more than the Brown Jr. Baby Cyclones cost less, ran longer, on comparable fuel, and had extremely easy starting habits. Even this writer was started in gas models in 1935 with a Model X Baby Cyclone.

We had the pleasure of watching the 1935 California State Fair Gas Championship Event held out on the old Franklin St. Airport in Sacramento. The columnist still recalls the spectacular climb of Henry Stiglemeir's "21," a Brown Jr. powered 5 foot span model but most of all, the long slow easy climb of Bill Atwood's Champion with a Baby Cyclone in it. As usual, the model drifted out of sight over the city of Sacramento, motor still running. What a thrill! The author never got over that demonstration and promptly built a Modelcraft Corben Ace with a Baby Cyclone in it! Never did get over the gas bug bite.

AS noted in the Ohlsson writeup, this highly prized win at the Sacramento Fair launched the Baby Cyclone on its highly successful career, lasting over four active competition years.

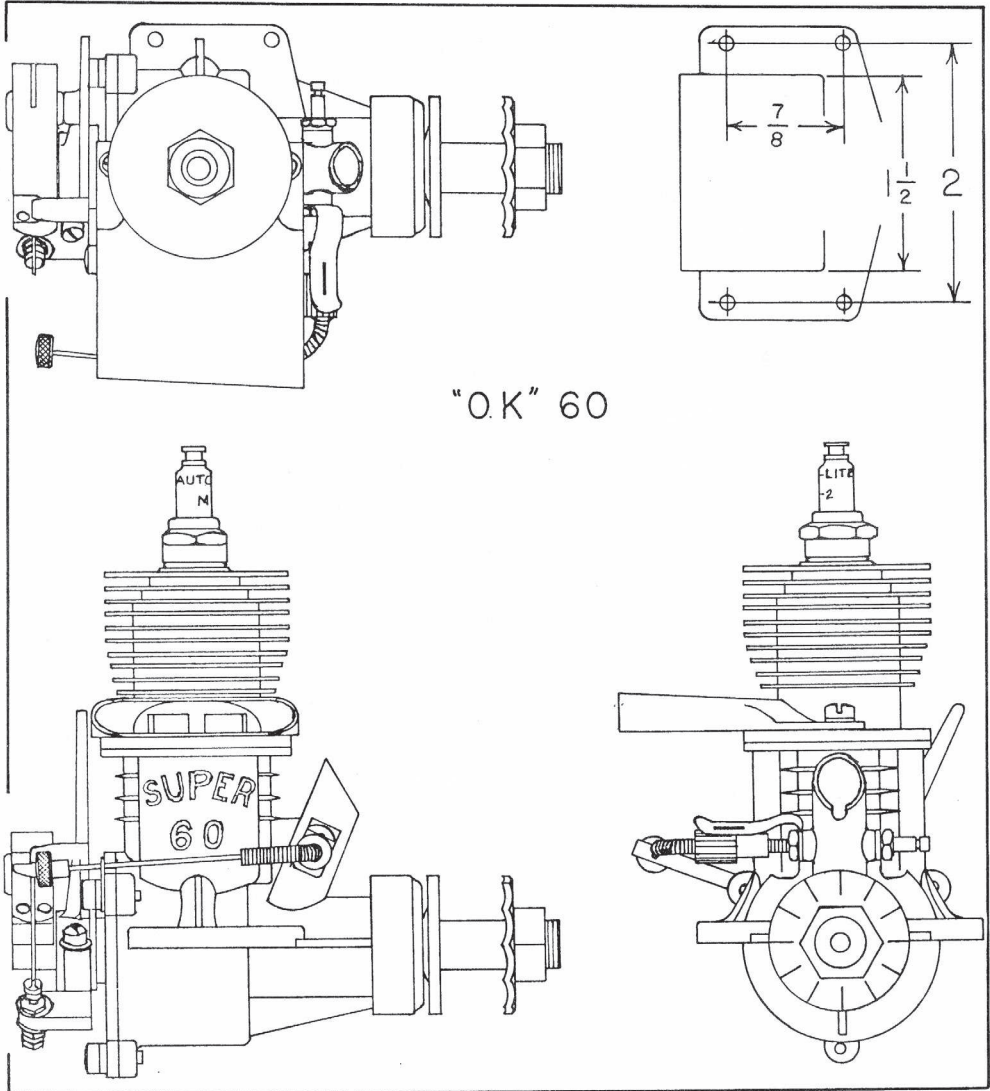

ENGINE THREE-VIEW

This month's engine 3-view features the OK Super 60 motor as manufactured during the post-World War II years by the Herkimer Tool and Model Works.

According to the story, Charles Brebeck, Sr., a highly successful business man heading up an auto parts and truck repair company in upper New York, was interested in manufacturing another product. When his boy, Charles, Jr., showed him one of the early engines, Brebeck Senior went to work and produced a new engine in two weeks that was comparable (and superior in many respects) to anything being manufactured at that time.

Improvement followed improvement as various models were produced. The Super 60 shown in the three-views was introduced in 1946. This garden variety was widely distributed under the advertisement "A Snap to Start." Properly wired and hooked up, the OK 60 did start easily, but was prone to give the operator a sharp rap across the fingers for improper operation, such as flooding, timer advanced, etc. OK 60 motors ran well on 14-6 and 13-6 propellers, their power being as good, if not better, than contemporary engines.

The popularity of the OK engine was limited, as most modelers preferred to have the timer more readily accessible in the front, despite its inherent danger. OK engines have enjoyed a modicum of success to this date, and as pointed out in previous issues, O.K. parts for most post-war type motors are still available from Ted Brebeck, Box 40, Mohawk, N.Y. 13407.

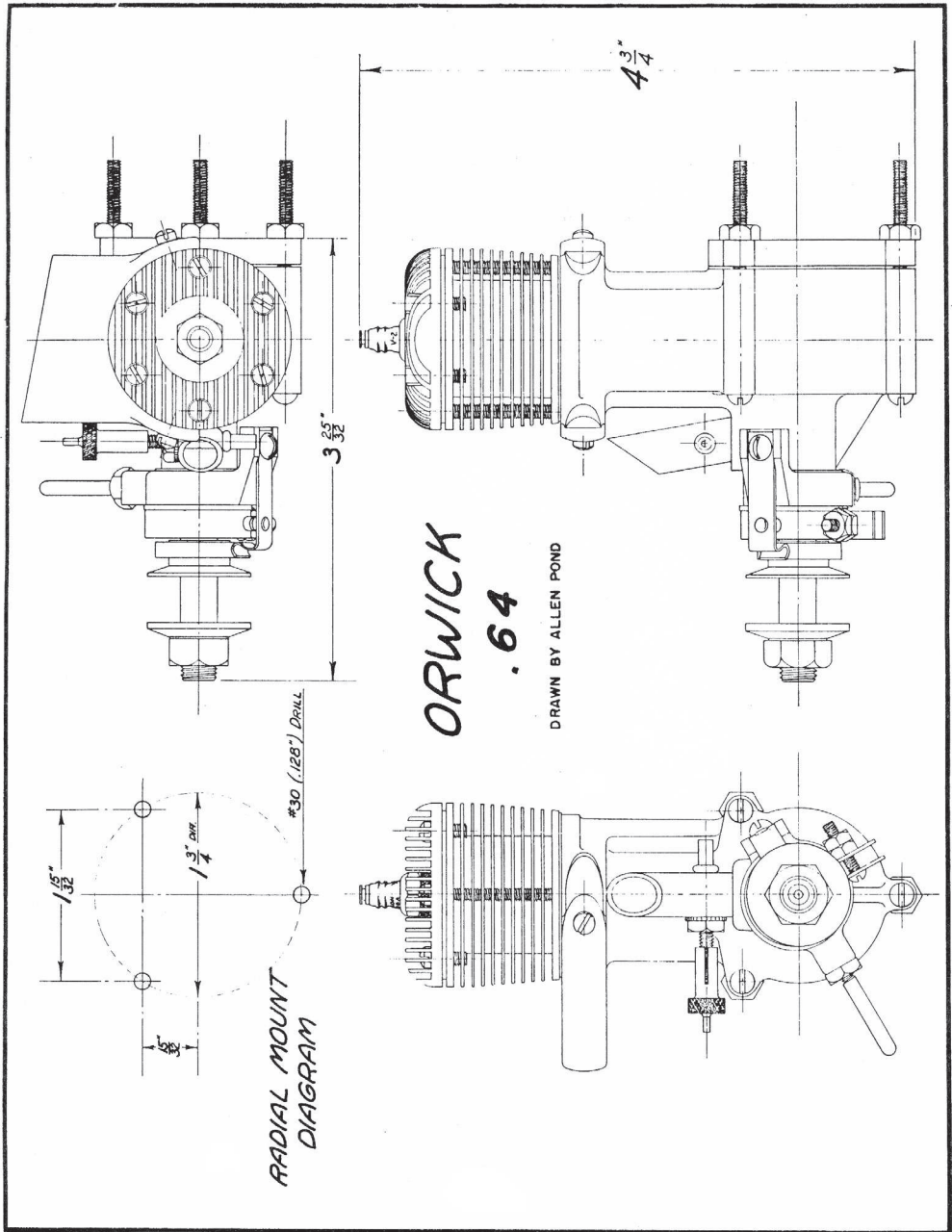

MOTOR OF THE MONTH

This month's subject is Henry (affectionately known as Hank) Orwick's engine that appeared directly after the close of WW II, in 1946. It is to be noted that radial type mounting dimensions are shown although special aluminum lugs were provided for mounting the Orwick on standard beams.

Hank (now deceased) was no Johnny-come-lately in the modeling game, as he was extremely active in Southern California modeling circles. His "Speedcraft" was one of the first successful low wing models. At that time, he was using Ohlsson engines exclusively. Being a machinist of excellent repute, and having a curious nature, Hank decided he could design a better motor than any that were on the market.

His first, called the "Miracle 60," was actually of .73 cu. in. displacement. This engine was so superior to any .60 being produced that it was one of the major reasons for a rule change in restricting free flight engine sizes to .65 cu. in. In the meantime, Hank produced a .64 engine that really was a powerhouse. Just the thing for a Comet Sailplane! Even today, the only thing that beats an Orwick powered Sailplane is another Orwick Sailplane!

Orwick engines start quite readily, but are unforgiving to an unwary modeler who has left the spark lever advanced. The Orwick will let you know the hard way! Being one of the first high compression engines, care must be exercised in starting.

Orwick produced other engine sizes, 32, 29 and 23, the latter sizes being aimed at the glow plug market. For those curious about the similarity of the Cunningham engine, it must be remembered that Cunningham was associated with Hank. Finally, losing patience with Henry, who was a perfectionist, Cunningham produced a .64 engine based on the Orwick. In later years, engine collectors Art Swift and Bruce Chandler gained control of the old Cunningham parts and produced quite a few for ignition enthusiasts. Cunningham engines are quite easy to identify, with their purple color, and compared to the green crackle finish that featured the Orwick.

After Henry retired from the engine business, "Hi" Johnson acquired the dies and parts, which became the basis for his series of successful Johnson 29, 32, and 35 series of engines. Try converting one to ignition and note the similarity of handling and starting to an Orwick. No question about the ancestry!

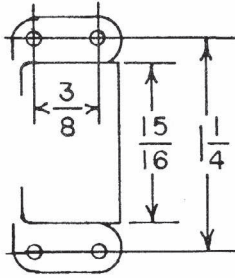

Drawn by TEX NEWMAN

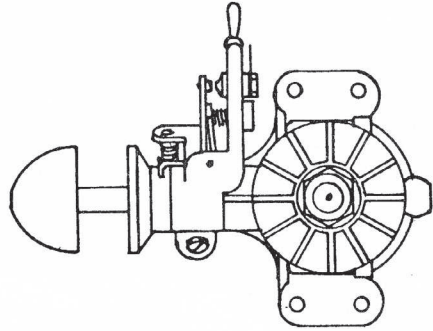

ATOM .09

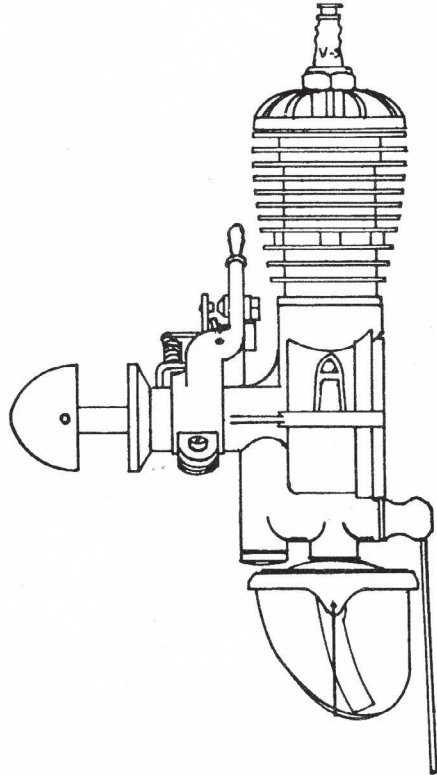
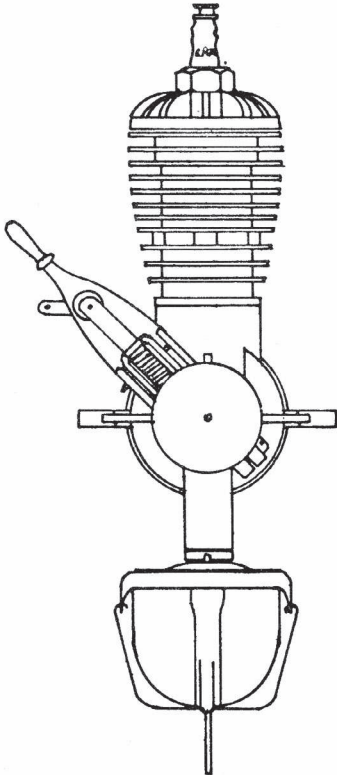

ENGINE OF THE MONTH

Not everyone knows that the Atom engine was the brainchild of Ray Arden, who gained such extensive fame with his Arden series of engines. Credit must be given to Ray for popularizing the small engine (under .10 cu. in. displacement) as darn few engines of this size were made commercially.

The Atom was almost an instantaneous hit when it first arrived on the market. Here, finally, was an engine with reliable starting qualities. Even this columnist had to have one. Upon viewing its size, the engine was promptly mounted in the cut-off nose of a standard rubber powered cabin model, on 1/4 inch thick balsa, and flown this way! With only 150 sq. in. of wing area, the model proceeded to amaze the writer with a seven minute flight! With others enjoying the same modicum of success, it was no wonder that almost everyone had one of these Atoms in his stable.

The first series of Atoms featured a very simplified carburetion system, consisting of an air choke that was variable by swinging the choke wire in an arc of 90 degrees. This made running of the engines extremely simple, but as the engine wore, vibration would cause the wire throttle to move. Later models featured the standard type needle valve body extended across the venturi.

Probably the foremost proponent and biggest booster of Atoms was the fabulous modeler, Louie Garami (now deceased). On a bet, Louie went to a contest on the subway, carrying his Atom powered gas model in a shopping bag! Before the boys had quit laughing, Louie had won first place in Class A and was taking the subway home! Some of the best known designs employing the Atom engine were Louie Garami's designs. To name a few; Stratostreak, Half-Pint, Wahoo, the redoubtable Molecule (Nats winner!) and a series produced for Polks called Hummingbird, Eve, Haymaker, et al.

No one uses Atom engines now, as most of the engine collectors have stored them away for posterity. If you have one, keep it, and enjoy it!

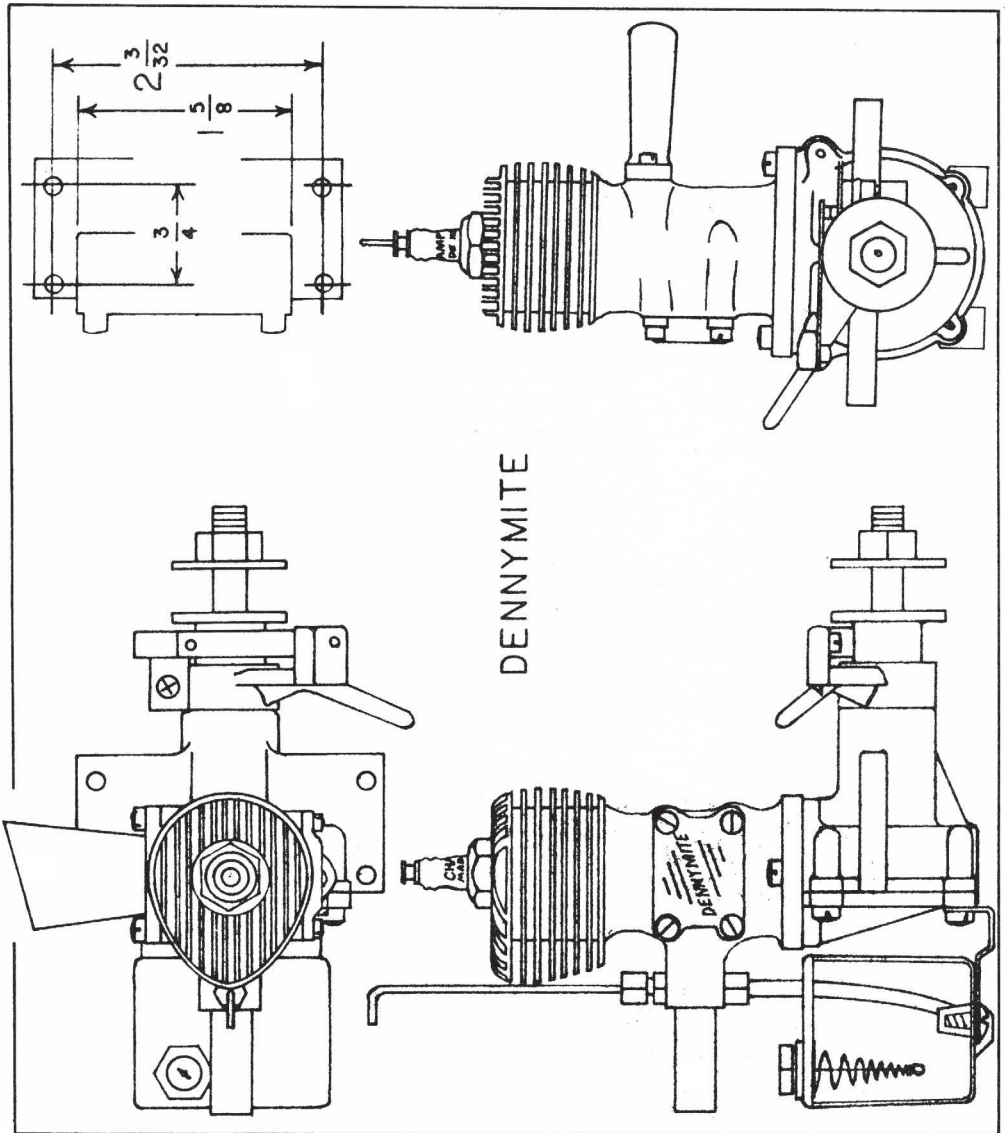

ENGINE OF THE MONTH

About the time that Brown, Atwood, and Ohlsson were starting to make names for themselves, a rather obscure fellow by the name of Righter produced several prototype engines that started and ran well.

About this time, the movie actor, Reginald Denny, also an aviation buff, got interested in the idea of marketing model airplanes as a business. Acquiring the rights to manufacture the engine, the motor was dubbed the "Dennymite" (in honor of the sponsor) and immediately became a good seller.

Made primarily of cast iron, the Dennymite was a good durable engine that ran quite well, considering the little known fact that it was only a .56 cu. in. displacement engine. Points were left open, giving it a rather crude appearance, but no modeler could ever complain of not being able to adjust the points on a Dennymite.

The Dennymite engine enjoyed its greatest success when it was paired with the Dennyplane (a Fletcher design) and sold either as a package, or in some cases, a completely ready-to-fly. In his days as a hobby dealer in Milwaukee, Walt Billett (now deceased) reported he always had a Dennyplane on hand and one or two building. It was a great combination, as the Dennyplane with its large cowl looked very much like a Belanca.

In later years, the Dennymite was used in race cars with a so-called Berg conversion. These cast iron engines then showed their true mettle (metal?) as they were able to stand the high wear rate imposed by the higher rpm required in race cars.

Eventually the engine rights were sold off, with several variations appearing, such as the PAC, the Kleiner, and even Ohlsson bought them up and produced Dennymite engines for a period of time! The Dennymite can truly claim to be one of the early successful motors that made this hobby as we know it now.

MIGHTY MIDGET

DRAWN BY ALLEN POND

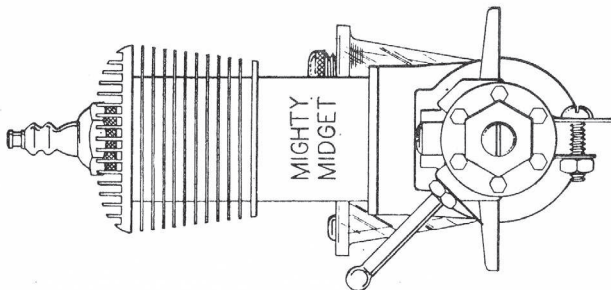
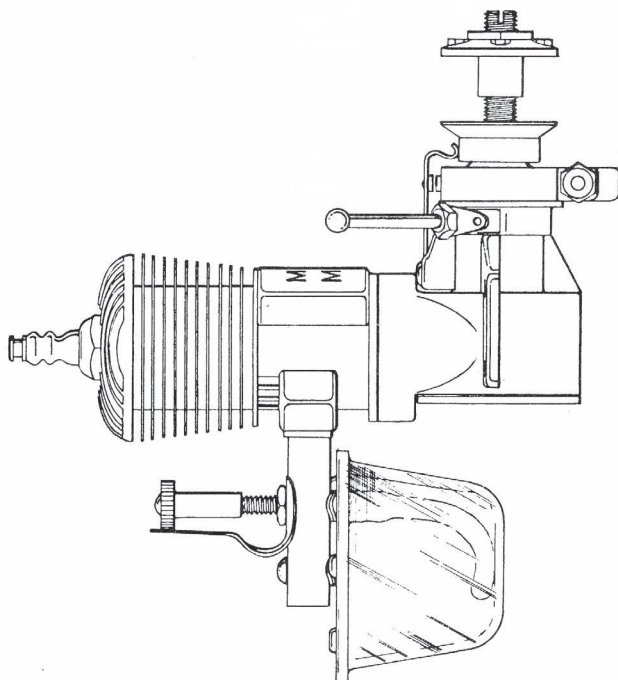
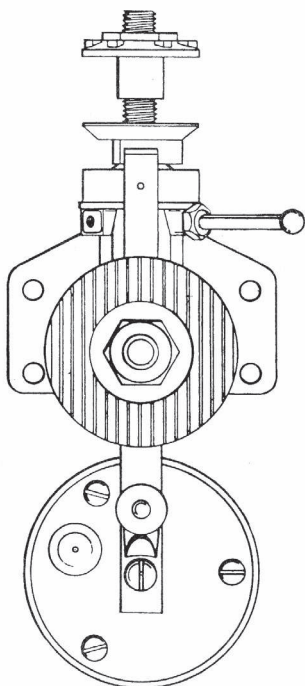

ENGINE OF THE MONTH

The time was 1936, and the Brown Jr. motor was setting the pace at \$21.50, with most all competition being in the same price bracket. With this representing a week's salary at that time, the Bunch Model Airplane Co., of Los Angeles, caused a sensation by announcing in the September issue of Model Airplane News a kit form of their Gwin Aero engine called the Mighty Midget, priced at \$9.85.

This was an exceptional breakthrough in price, following a trend started by the Curtiss-Wright Institute people then marketing the Baby Cyclone. To sweeten an already good deal, the Bunch Scorpion Major airplane kit was offered in combination with the Mighty Midget for \$12.00. Many a Southern Californian flying field was dotted with this combination.

Later on, the "muff" head design of the Gwin Aero was changed to a finned head, and a kit of this was produced as a Gwin Aero kit at \$11.35. However, the Mighty Midget engine was the one that sold. Most surprising, even to this columnist at the time, was the ease with which his brother was able to assemble the engine, and to top things off, it ran well! This was the author's first experience with a ringed piston type engine, and the compression of the rings was looked down on. The starting procedure was a shade different, with the engine requiring more choking to place enough gas and oil in the chamber to build up compression.

The Mighty Midget was a new size engine, approximately a .45 cu in displacement, that opened up a whole new field of model plane designs of smaller size. With everyone highly prizing a fitted piston type engine, Danner Bunch should receive full credit for popularizing ringed piston engines. Bunch proved the validity of his design by producing such complete engines as the Gwin Aero, Tiger, Cobra, Warrior, and later on, the Contestor. Truly a shame that Danner Bunch cut short such a promising engine design career.

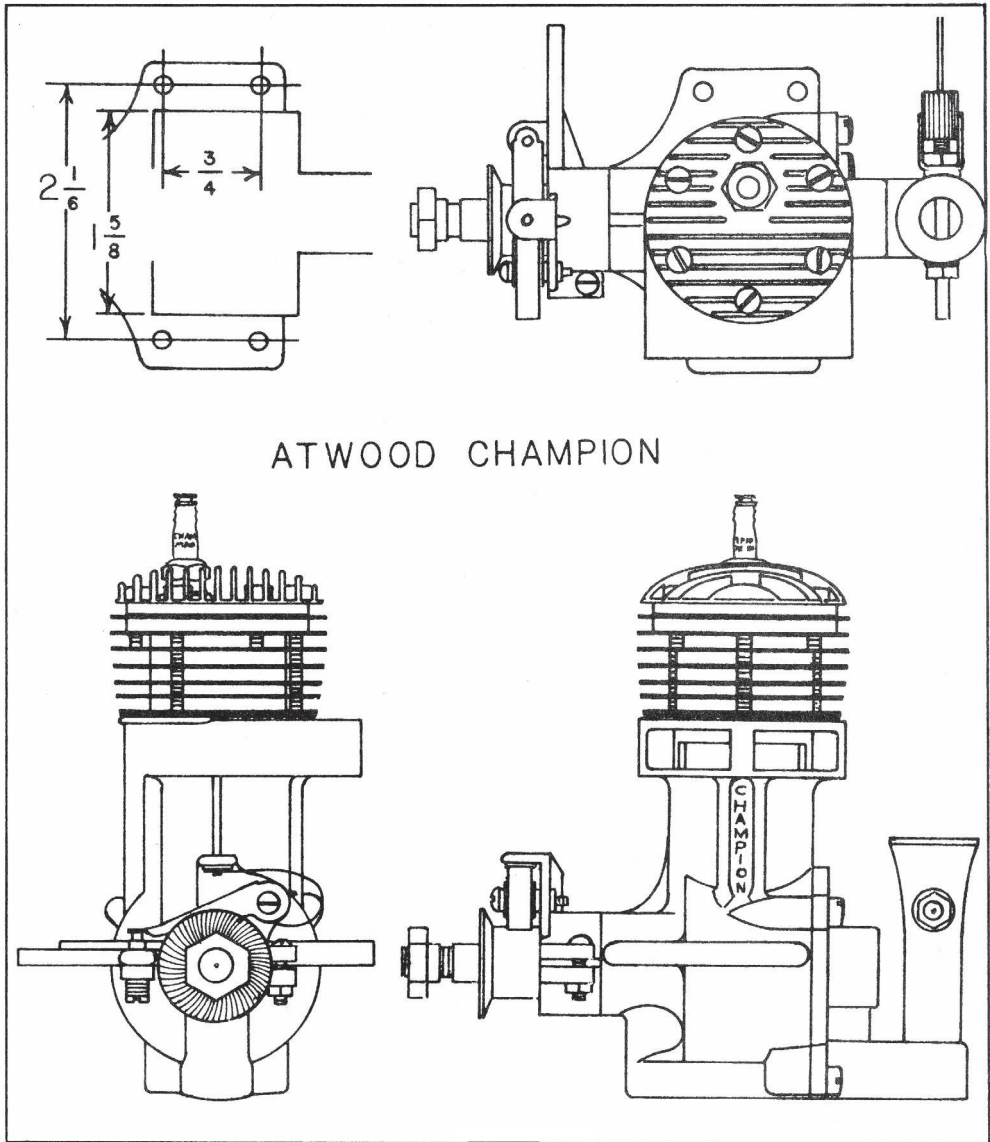

ATWOOD CHAMPION

MOTOR OF THE MONTH

During World War II, with materials in critical supply most model engine manufacturers turned their talents to producing small wartime accessories. When it was seen that defeat for Germany and Japan was inevitable, it was then that all the garage experimentation with engines that had been going on finally came to light.

The year 1945 was the one for new engines, and Bill Atwood's was no exception. In a small ad, Wentzel and Atwood Co., of Los Angeles, announced the new Atwood Champion Model H, priced at \$23.50. Thus opened the January issue of Model Airplane News for Bill Atwood and his myriad amount of engines.

The engine proved to be powerful . . . something the airplane, car, and boat boys were looking for. The immediate success of this motor brought on the Model J, followed by the Glo-Devil version. In every case the Champion gave good performance.

As with the Herkimer engine, many modelers did not like the rear intake, as this made mounting and cowling the engine a little more tedious than the simpler front rotor engines.

Regardless, those fellows who appreciated good power used Atwood engines. The writer has yet to hear better sounding ignition engines than those Champions in Bill Burgess's Playboy Cabin, or John Droulliard's Westerner, the latter being the most spectacular both in performance and crash! To summarize, the Atwood Champ was Bill's best .60 cu. in. engine, regardless of any other special engines he built.

Incidentally, for those who wonder what happened to Bill Atwood, he has only recently retired from the L.M. Cox Mfg. Co., where he spent many years developing and perfecting good Tee Dee engines. Look at them carefully, you can see the Atwood influence!

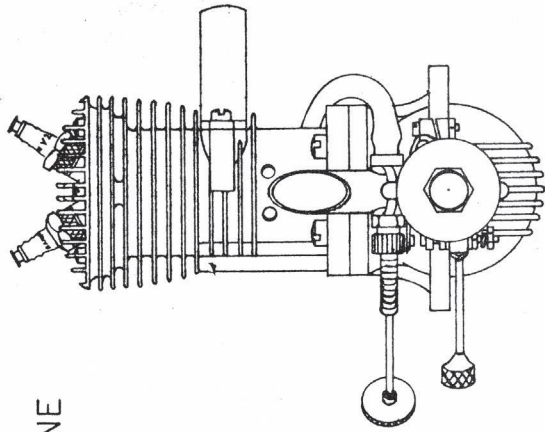
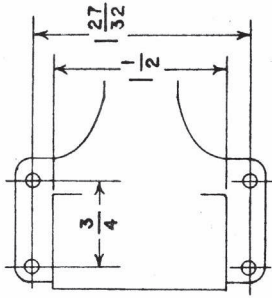

SUPER CYCLONE

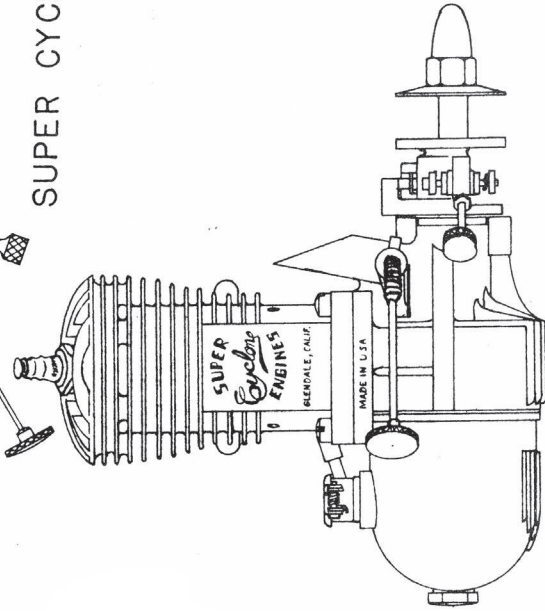
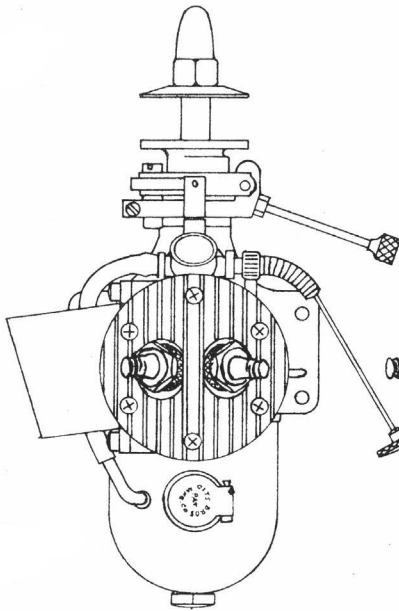

ENGINE OF THE MONTH

Super Cyclone! What a great name that was in the forties. In spite of the fact the "Cykes" (as they were popularly called) were a direct mail order sale and not handled by hobby dealers, the Model G Super Cyclone was a great seller.

Not many people know that the original Cyke was .64 cu. in. displacement. However, the race car craze was in full swing in Southern California at that time. The rules allowed for a maximum displacement of .604; so quicker than you could say "Super Cyke", Bill Atwood had reduced the displacement to .604. However, after getting into full production, the ironical twist was that the model car racing game collapsed. Atwood was left with a flock of .604 engines; hence, with parts and service available for this size, the Cyke was reverted to size .64.

Interestingly enough, in the transition from the Baby Cyclone, Model F to the Super Cyclone, Model G, quite a few prototypes were built. In viewing the Cyclone collection of Larry Boyer, it is interesting to see the engine start as an updraft .60, similar to the Baby, and gradually change to the present down-draft intake.

An anecdote is in order here. Larry Boyer was so pleased to acquire the Super Cyclone prototypes that he was publicly displaying them. Whether Joe Wagner was fed up listening to Larry, or

just having fun, he spoke up during one showing and said, "Oh yeah, I know those engines. Those were the ones that were stolen from the Curtiss-Wright Institute Plant." Larry turned white. To this day, Larry has never shown the prototypes again. Aw c'mon, Larry, bring them out, the statute of limitations expired 30 years ago!

Super Cyclones lend themselves very readily to "hopping up". High compression heads were numerous, among the more popular being the "Denver" and "Texan" heads. This, plus opening the intake slot on the rotary shaft and "packing" the crankcase with thicker crankcase back plates, made the Cyclone a formidable opponent in any competition.

Much later in the game, around 1962, Bob McCord acquired the rights, dies, and parts to the Super Cyclone and Anderson Spitfire engines, from Mel Anderson. McCord did a fine job of producing good engines, but unfortunately, the engines seem to have a jinx on them, as all owners have had marital problems directly after acquisition! This has been the primary reason the engine dies have changed from Anderson, to McCord, to Quentin, to Mrock, and now to Karl Carlson of San Jose.

At present, Karl's plans are only to sell parts until such time elapses that he is able to set up a production facility for the two engines. The Super Cyclone will live again!

ENGINE OF THE MONTH

This month's engine is the postwar version of the May Co. Silver Rocket, which was first advertised in the July 1945 issue of Model Airplane News. Called the Rocket Victor Motor, the engine was listed at \$22.50 in a rather modest initial advertisement.

Corr's Hobby Shop, in Washington, D.C., carried a steady ad for this motor in its hobby parts advertising page. As sales increased, the Corporate Products Inc., jumped to full page advertisements. As Bunch had proven it before the war, there was a definite demand for a .46 cu. in. motor.

In those lush years right after World War II, when everyone had saved their money for four years, any manufacturer who had a half-way decent running motor, enjoyed a successful series of sales years. As 1948 approached, things started to tighten up, and it was then that the Ohlsson & Rice firm decided to drastically drop the price of its 60 motor from \$18.50 to \$9.95.

With the tremendous number of automatic screw machines, lathers, etc., accumulated during the war, it was simply a case of the big production companies squeezing out the smaller competitor. Along with the Pierce, Everson, et al, the Rocket suffered the same fate as the myriad of engines on the market, i.e., falling off of sales. Eventually, the Rocket motor production was discontinued.

Rocket motors are surprisingly good running engines. Most modelers make the mistake of putting a .46 size motor, such as the Rocket, in a model designed for a .60. When properly combined, the Rocket motor can more than hold its own in competition.

For those interested in specifications, the Rocket Motor featured a 13/16 inch bore, 7/8 inch stroke; displacement, .46 cu. in.; and a weight of 8 ounces. For flying nowadays, the Rocket engine unfortunately requires a 1/4 inch V-2 spark plug, which is in rather short supply.

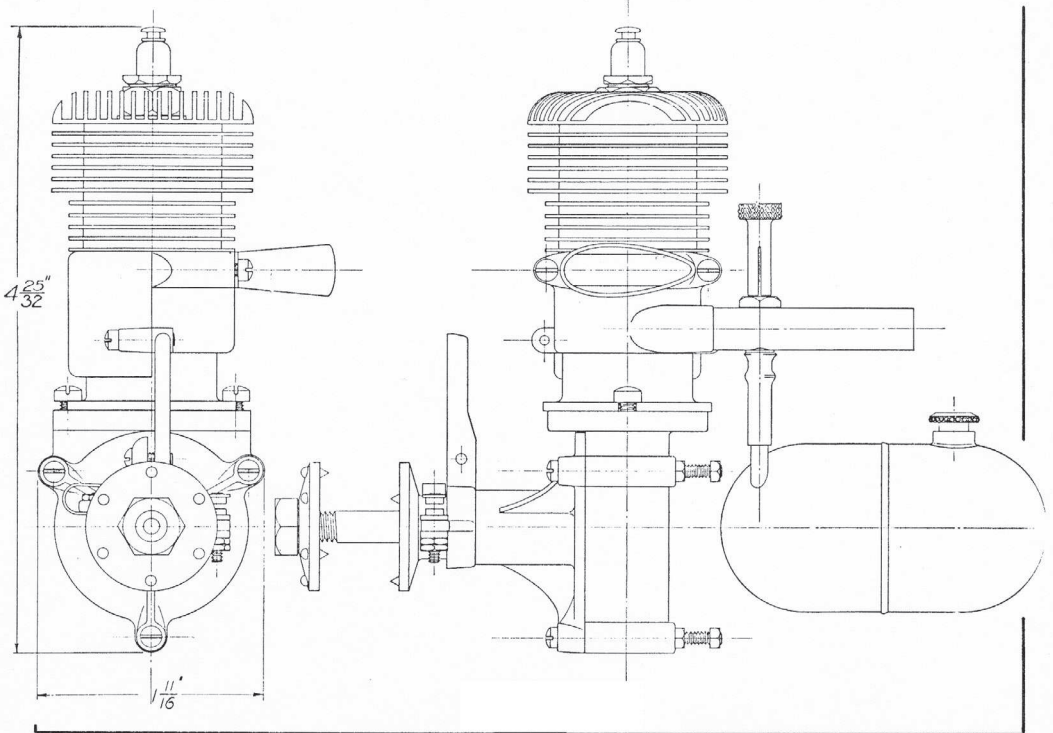
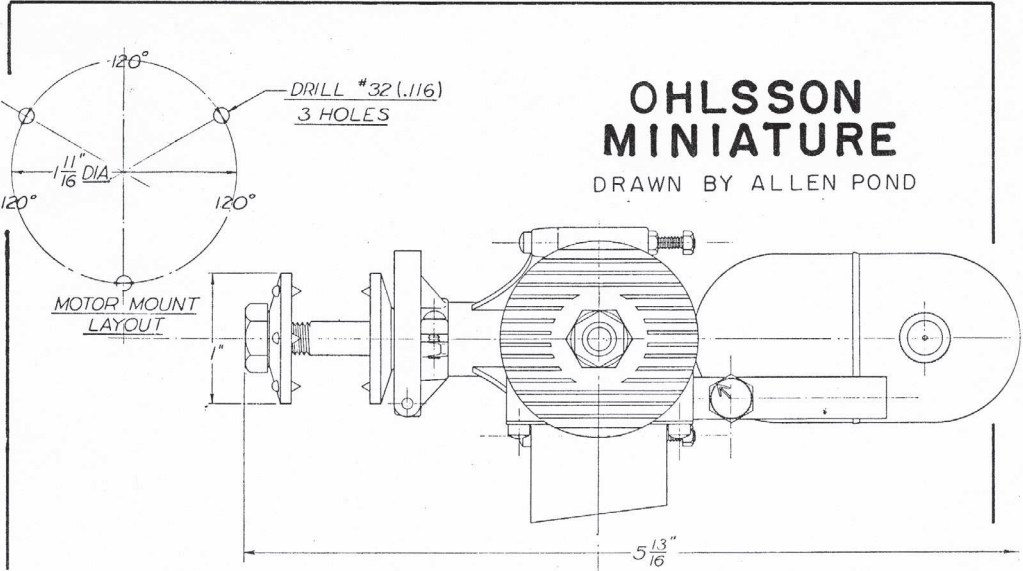

ENGINE OF THE MONTH

Late in 1936, all modeling in Los Angeles was agog with rumors of the hot engine Irwin Ohlsson was putting out. This engine was called the "Miniature" and sold for \$18.50 (Brown Jr. was \$21.50).

From its humble start in a garage-type operation, Ohlsson, and his partner at that time, Frank Bertelli, moved their operation to the Alvarado Street plant. This was the first major step for Ohlsson in engine manufacturing.

At that time, Irwin was sub-contracting a considerable amount of machine work to Harry Rice. Several factors led to Bertelli leaving the firm and it was only a matter of time until Harry Rice became Ohlsson's partner. With the James engine (as manufactured by Rice) fading and Ohlsson needing a real production man, it was a natural meeting.

The first miniature engine featured a duraluminum head produced in conjunction with Frank Bertelli. Only 126 aluminum types were manufactured, making this model a real engine collectors item. This "original" was a "two-bolt" type, that is, the exhaust manifold was held on with two bolts. Open type ignition points were a distinctive feature of this engine, as were the cooling fins which formed the famous "step-fin" head. All miniatures featured these characteristics.

The dural model was followed by the "two-bolt" steel head and cylinder type. By the time this model arrived, Harry Rice was in charge of production. Interestingly enough, the first tanks employed on these motors were modified brass carburetor floats which adapted admirably to the miniature engine.

The engine, with a $7/8$ inch bore and $15/16$ inch stroke, was nominally rated at $1/5$ H.P. (similar to Brown Jr.). Although the displacement was not specified, it was a slight bit over .60 (.62). The motor was provided with radial mounts only, although later on, custom-made mounts were manufacturing to all low different methods of mounting.

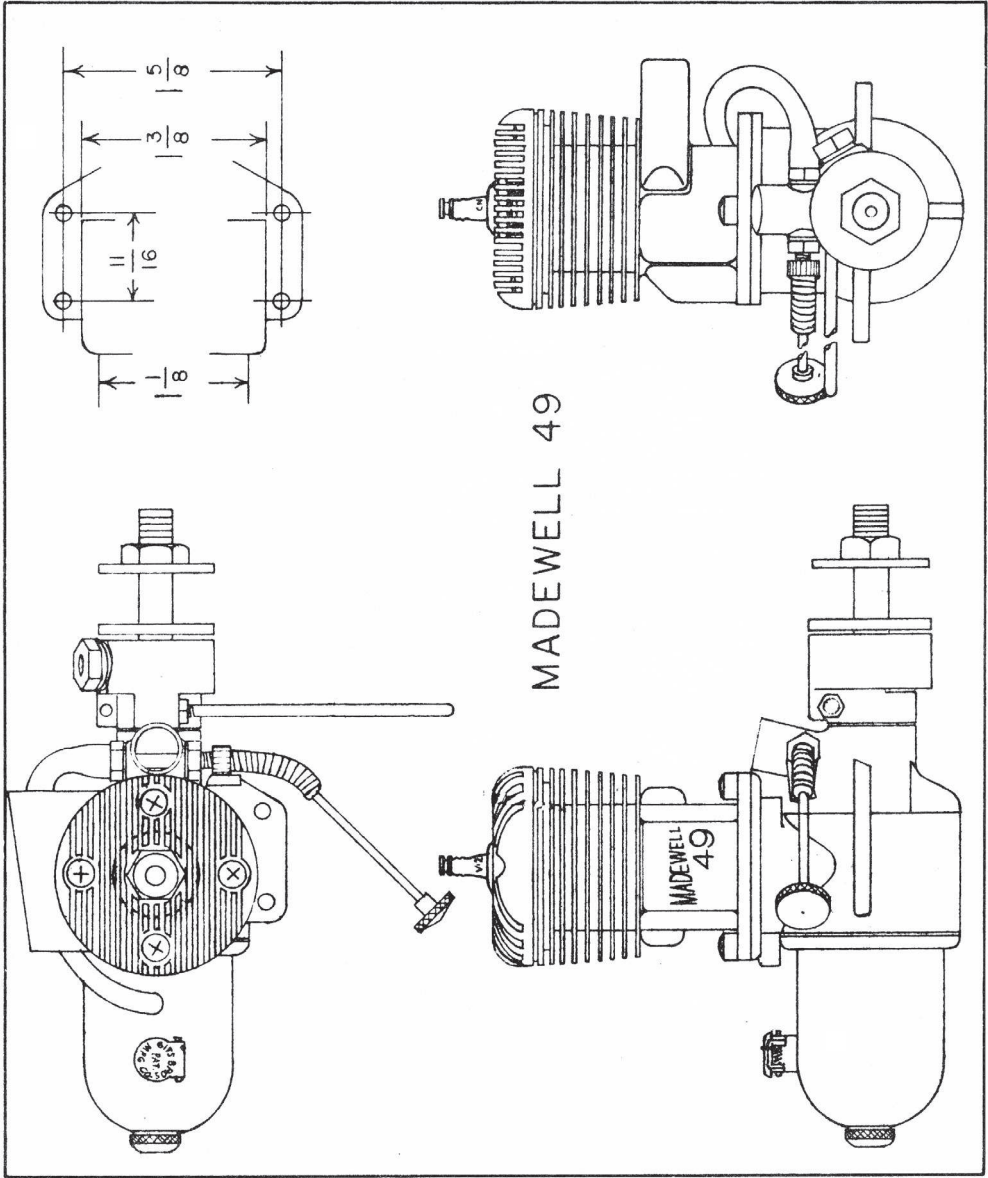

ENGINE OF THE MONTH

This month's engine, the Madewell 49, was a real puzzler for positive information regarding its design and source. Worst part about the writer's dilemma was that he lived in San Francisco while the motor was being produced across the bay in Oakland.

When one first sees a Madewell 49, one is immediately impressed with the idea that this engine is a scaled up version of the late square-port Vivell 35. Small wonder as Jack Keener, designer of the Comet 35, (the size of the Vivell 35 series) was one of the team that helped evolve the Madewell motor.

As a side note on Jack Keener, although he designed the original small Madewell engine, the Madewell 14 was the brainchild of Harry Congable, owner of Irrigation Pipe Co., who dabbled with the engine business as sort of a hobby.

Mr. Hurd, proprietor of Electro-Spray Co., financed the team of Jim Brown, Jack Keener, Harry Sharman, and Charlie Pottol, who developed the motor. There are unsubstantiated rumors that Al Hovsepian, producer of the micro engine, had a few contributions to the design.

In any respect, the Madewell 49 was a real fine running engine. Matter of fact, its lightness and power attracted a considerable number of converts to this engine. Originally aimed at the control line market in the postwar boom years, this engine has turned out to be one of the top free flight engines in its class size. First advertised in the November 1946 issue of Model Airplane News for \$18.00 (less coil and condenser), its slogan was "The 49 that goes like a sixty." They weren't kidding!

For the technical minded, the Madewell 49 featured a bore of .891, and stroke of .783, to give a displacement of .49. With tank, the motor weighed nine ounces. The crankcase and carburetor formed one aluminum alloy casting, with the back plate screwed in and forming part of the formed steel tank. The cylinder and cooling fins were machined from alloy steel bar stock, with the bypass and exhaust stack brazed on. Piston was Mehanite with a tubular steel wrist pin provided with bronze end-pads. As with so many engines of that era, the crankshaft was ground from one piece of steel, and the connecting rod was die-cast from aluminum alloy with bronze bearings. V-2 spark plugs were popular then, and the Madewell was no exception in featuring this size plug.

In reading a test report of the engine's running ability, the same trap was fallen into again, as nothing but .60 size 14 and 12 inch dia., 6 inch propellers were used to check the r.p.m. The writer favors an eleven inch propeller, which turns up excellently. Do not exceed six inch pitch, as this motor loves to turn up.

For owners of Madewell motors, parts are readily available from Karl Carlson, 14600 Ramstead Drive, San Jose, Ca. 95127. In talks with Carl, he regrets that the Super Cyke parts are slow in coming, but in the case of the Madewell, no problems. So power up that Playboy senior of yours, it does make a nice flying free flight combination!

BANTAM 19

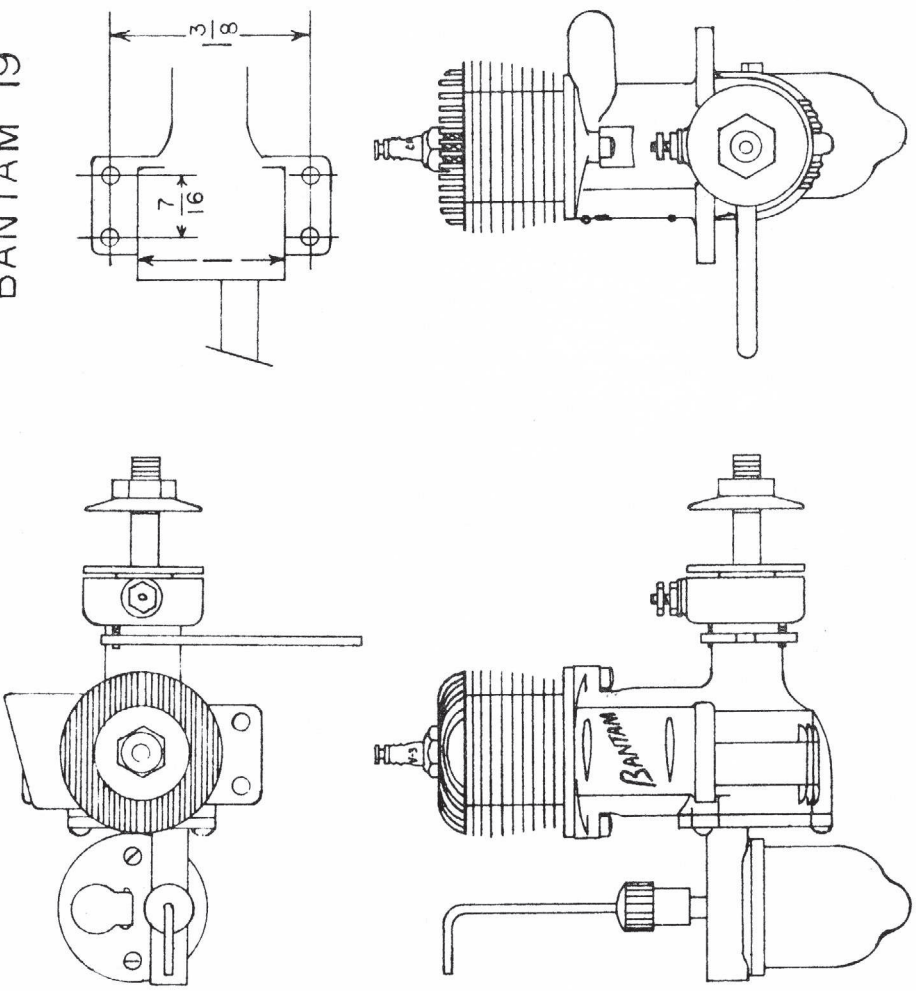

ENGINE OF THE MONTH

This month's subject, the Bantam 19, needs no introduction to the old timer. As designed by Ben Shereshaw, this engine was a must in anyone's stable for Class A competition for ten years.

Ben Shereshaw, who was responsible for many designs dotting the early magazines; i.e., Flying Aces, Air Trails, and Model Airplane News, got interested in building a small engine in 1938. Being a machinist by trade, it wasn't long before Ben had a Class A engine of .16 cu. in. displacement.

These early engines were highly prized and very much in demand. As Henry Struck noted, "It was a six months wait for my engine but boy, was it worth it!" The Bantam engines, made with excellent precision, ran every other Class A engine off the market. Even the Ohlsson .19, put out by O&R, suffered in sales to the point that Irwin Ohlsson had to admit his best small engine seller was always the .23. The .19 O&R engine sold poorly in comparison.

Around late 1939, Ben decided to increase the displacement of his Bantam to .19, as this was the upper limit of Class A. Why give the other fellow an advantage, reasoned Shereshaw. This was the real bread-and-butter engine that brought Shereshaw fame and (some) fortune. The Bantam won practically every event class in which it was entered. Actually, it was not until the advent of Ray Arden's 19 that the Bantam had any serious competition. Like all good things, the Bantam eventually passed from the motor market, as Ray Arden's engine proved to be too much for it.

For those who collect engines, there are four distinct Bantam engines, the .16, the magnesium case .19, the chrome coated Bantam .19, and the OK version; the company that eventually bought up Shereshaw's business. The biggest advantage to Bantams was their lightness, weighing only 3-3/4 ounces.

Specifications of the post war model indicate a bore of .656 and a stroke of .590. The crankcase and lower portion of the cylinder were die-cast magnesium alloy with an integral exhaust stack. The cylinder barrel and head were made from one piece of high manganese steel with the cooling fins machined from cylinder stock. The inside, which was the secret of Ben's success in engines, was micro-bored to a very high-finish. The mating portion, the piston, was machined and ground to very close tolerances. The writer hadn't seen fits like this until Leroy Cox, in his mass production genius of temperature controlled centerless grinding, made the Cox engine an outstanding piece of precision fit.

For those who have Bantam engines and wish to use them (much to the Engine Collector's horror) in a suitable free flight, probably the best combination is with Carl Goldberg's Interceptor, either the 42 or 48 inch version. Bantam engines were not noted for turning large diameter propellers. The writer recommends nine inch dia. with four inch pitch to get the Bantam turning in the 10,000 rpm range. Using any other combination of larger diameter and/or higher pitch would drastically drop the rpm indicator by at least two thousand revs. In short, keep the motor turning up to develop maximum power.

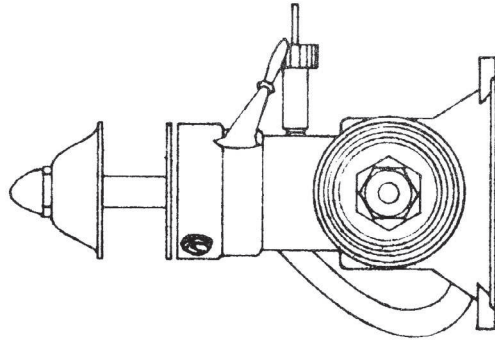
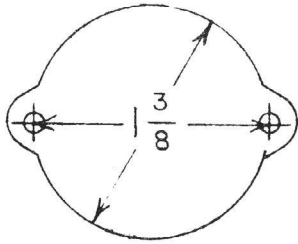

ARDEN .099

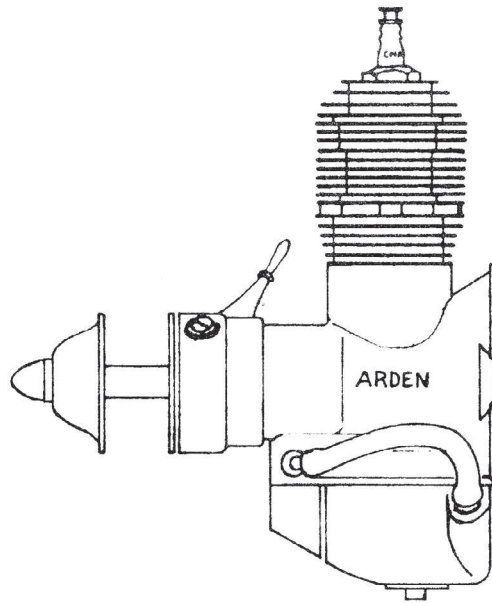
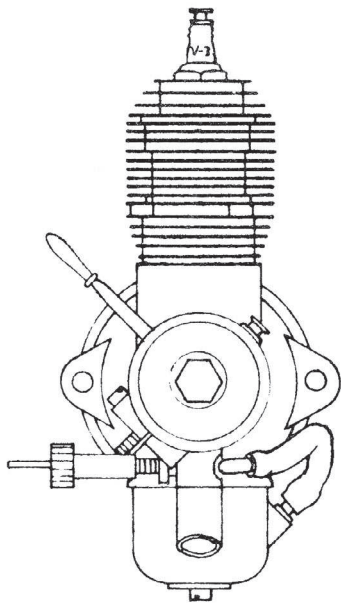

ENGINE OF THE MONTH

The most startling motor directly following World War II was the Arden .099. If the modelers thought Ray Arden's Atom 09 was a cutie, the Arden was a real powerhouse by comparison. Best part of all, the Arden started real easy and needle valve adjustments were simple. The Atom, on the other hand, was a mite tricky to start, hence many would-be Class A type modelers shunned the small engine in favor of the larger.

The Arden was an absolutely radical engine for its day, featuring complete 360° porting. For those who didn't like to scorch their fingers, an exhaust attachment was made to deflect the exhaust port and starboard (left and right, you landlubber!). The bypasser appeared to be broached in the barrel but actually, they were a series of splines machined by an internal gear cutter.

On the intake, the original Arden engines were provided with throttle arms. However, after some running it was found (as in the case of the Atom) that the arms would move too easily, making the engine a little critical for settings. Subsequent models featured a standard needle valve that found a more favorable reaction among modelers.

Arden's engine was sensational in that it established many firsts for an engine of its size.

1. Main ball-bearings.
2. Motor mount (radial) was integral with the gas tank.
3. Fully adjustable timer points.
4. 360 degree exhaust.
5. Splined by-pass.
6. 2.25 ounces bare weight.

Full page advertisements in all major modeling magazines announced the arrival of this novel engine, and in less time than it takes to describe the action, the Arden .099 was adopted wholeheartedly by the modeling fraternity. The terrific success of this engine set the stage for the advent of the Arden .199, another tremendous engine and another story.

For the technically minded, the Arden featured a bore of .495 and stroke of .516 giving a displacement of .097. The sensational light weight of two ounces now made it possible to build 9 to 12 ounce models. Interestingly enough, the cylinder head is aluminum, with a chrome moly 4140 steel piston. No wrist pins were employed (ball joint employed) which gave a beautiful fit with the steel cylinder (the real secret of success for later Cox engines).

The fully adjustable timer points were easily accessible, the fixed point being inserted into an elongated hole permitting travel left or right. Adjustments are made by loosening the upper point and tightening until proper clearance is obtained.

Running tests of the Arden .09 revealed that it truly was a hot engine, turning 8600 rpm on a standard 8-4 propeller. Even with a nine inch propeller, the motor turned 6,000 r.p.m. Of course, these figures were obtained using standard 3 to 1 mix. Using Blue Blazer, an alcohol-caster oil mix, the engine turned even better. Finally, when Ray Arden came out with his glow plug, the Arden 09 was truly a potent Class A engine. Too bad Ray died fairly early in life, as his contributions are missed.

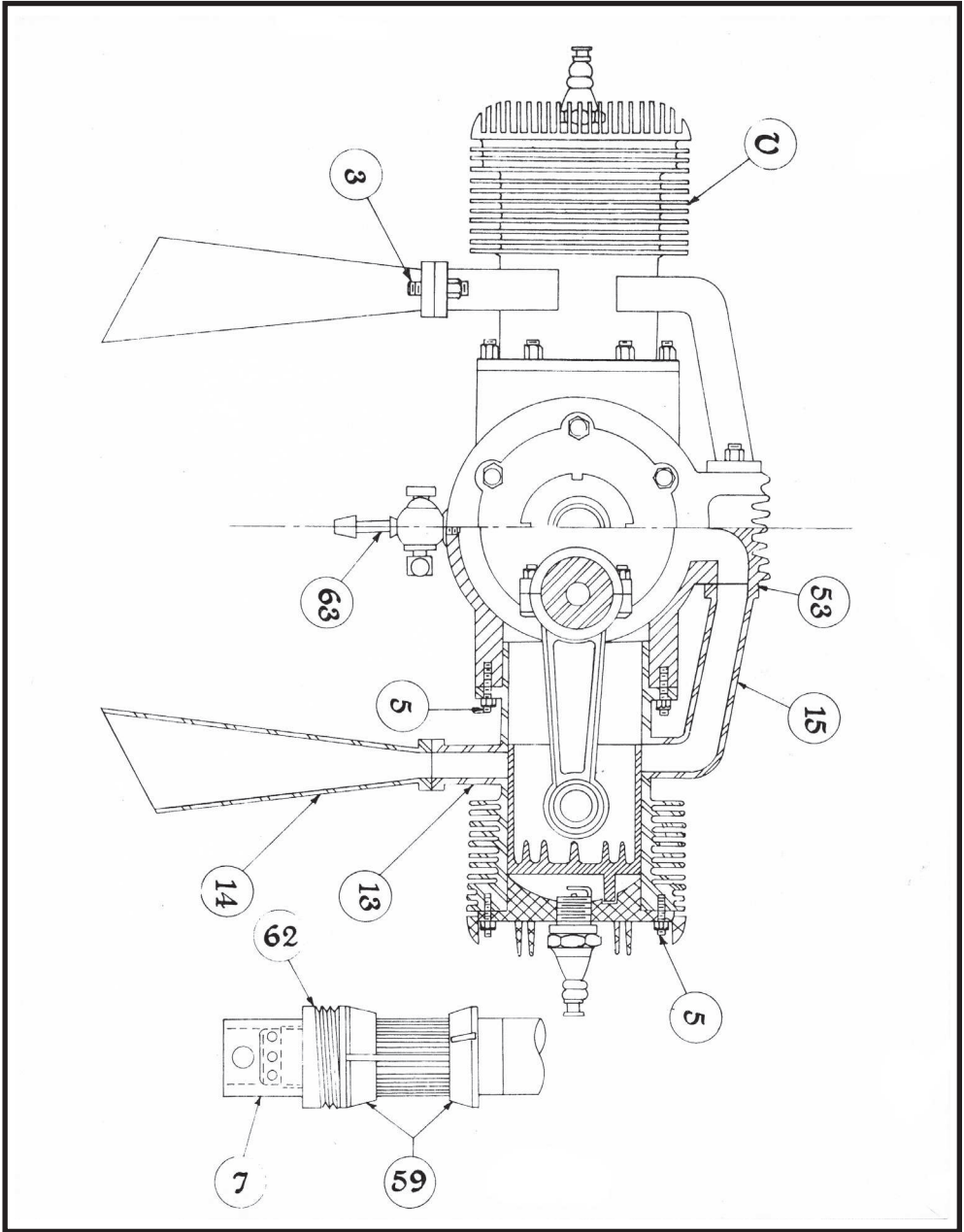

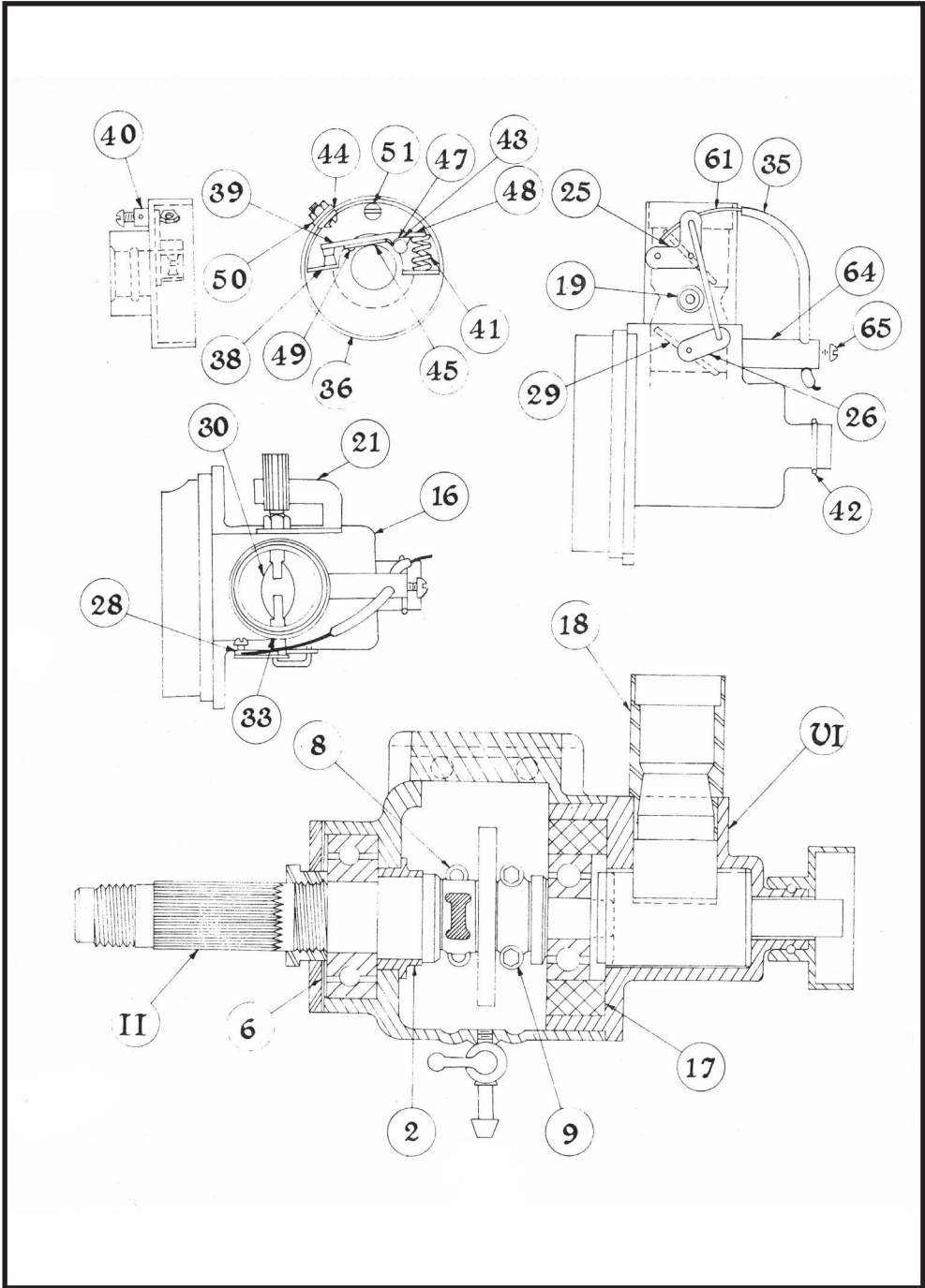

ENGINE OF THE MONTH

This writer is pleased that he has one avid reader of his column, as he received a mailing tube made of Coors aluminum beer cans from Irwin G. Ohlsson, no less! Inside were a lovely set of blueprints with complete three-views and bill of materials for the Ohlsson Twin used in model studies by Consolidated-Vultee. A complete writeup was made in the July 1946 issue of Air Trails showing the application of Ohlsson's engines, hence only a small portion will be repeated.

E. G. Stout, head of the Hydrodynamics Group of Consolidated-Vultee had been fostering a series of studies in dynamically similar models of proposed full size aircraft. With radio control becoming feasible, he decided to build a 1/8 scale size twin engine flying boat known as the XP4Y-1. It was then that the Ohlsson and Rice firm was invited to build a twin cylinder engine to specifications to simulate the 2,000 h.p. R-3350 engines in scale horsepower and r.p.m.

Ohlsson responded with an engine that was highly successful for the purpose required, using two bladed propellers (instead of the scale three bladed types in full scale) that gave static scale thrust at scale r.p.m. Rated at 1.6 brake horsepower, these engines swung a 24 inch prop (1/8 scale of 16 ft) at 4,200 r.p.m. So successful was the initial twin engine flying boat model, a four engine version was modeled thereafter, using the same engines.

In all, Ohlsson states there were only 26 engines manufactured. Thanks to the historical digging by Bob Von Kinsky, who was collecting Ohlsson engines exclusively, several of the engines are now in the Jack Passey collection. Von Kinsky tracked down E. G. Stout, living in West Hollywood at the time, and was able to obtain several of the engines still around the old Consolidated plant. From an engine collector's standpoint, this was an outstanding piece of research and best of all, finding a few of the original engines employed in these experimental models.

The drawings that have been traced by Allen Pond were originally in the custody of Doc J. P. Young. In running over his old files, he found the blueprints he had received from Irwin and in less time than it takes to tell about it, returned them to Irwin who in turn forwarded them to SAM/01. You, the reader, are the winner!

For the technically minded, Irwin supplies the following statistics: weight, approx. 3 lbs.; rating, 1-1/2 H.P. @ 4200 r.p.m., static thrust 21 pounds; fuel, standard gasoline and oil at the regular three to one ratio.

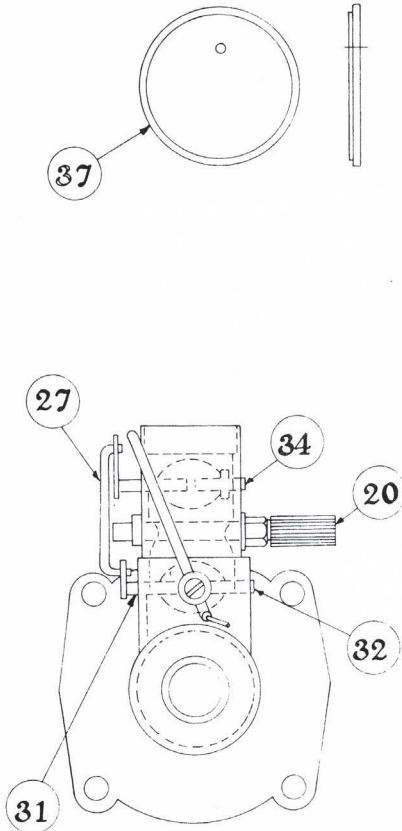

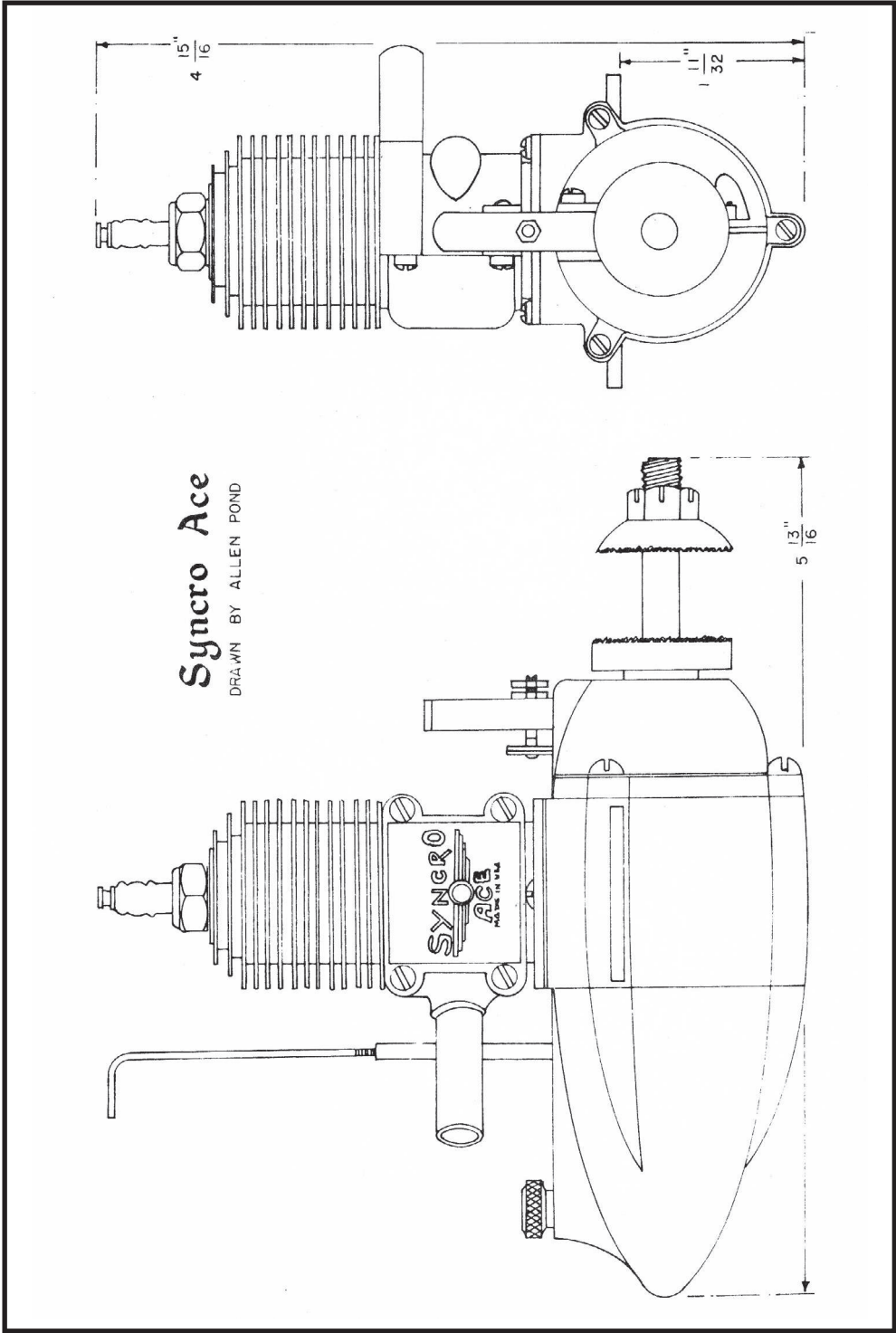

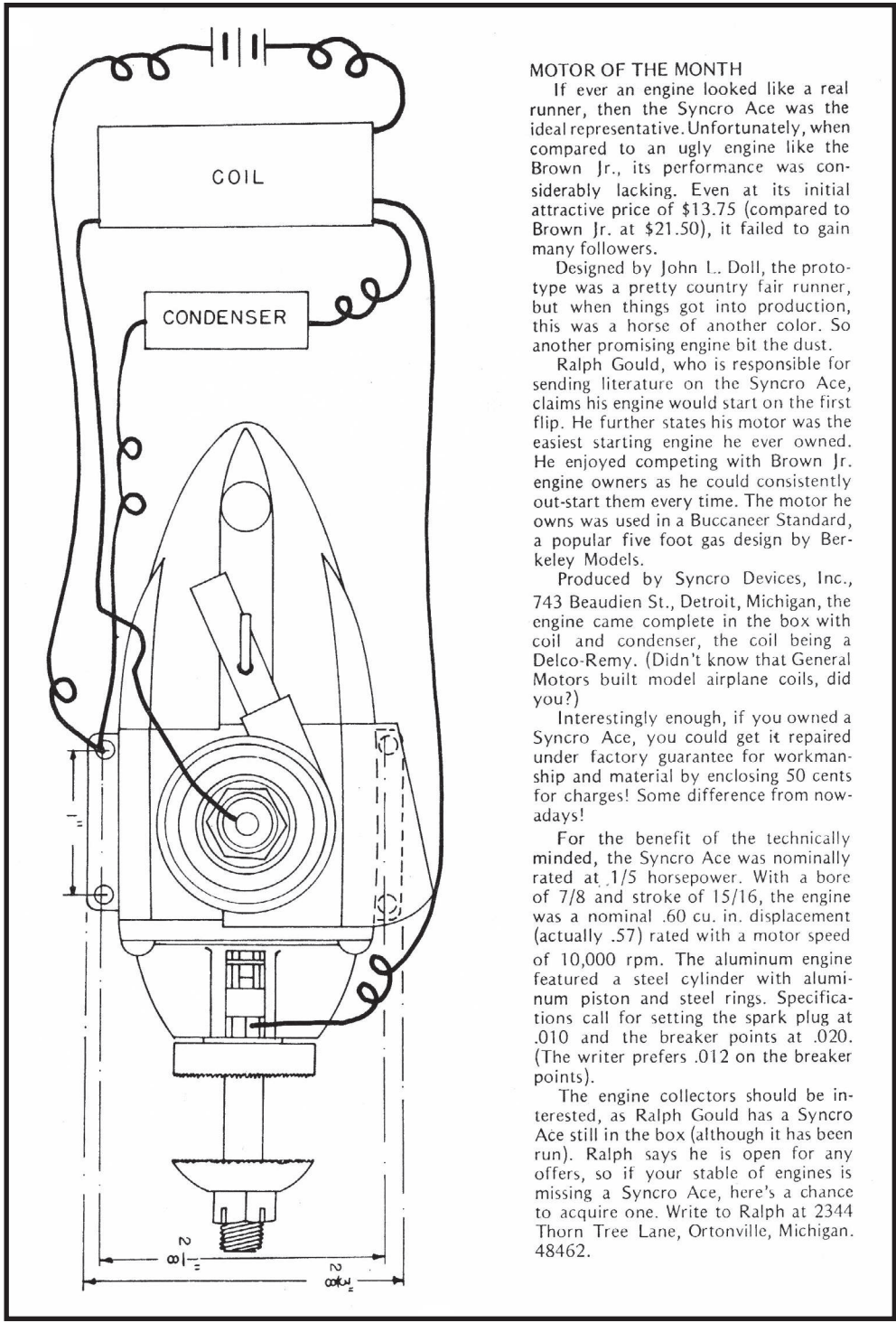

MOTOR OF THE MONTH

If ever an engine looked like a real runner, then the Syncro Ace was the ideal representative. Unfortunately, when compared to an ugly engine like the Brown Jr., its performance was considerably lacking. Even at its initial attractive price of \$13.75 (compared to Brown Jr. at \$21.50), it failed to gain many followers.

Designed by John L. Doll, the prototype was a pretty country fair runner, but when things got into production, this was a horse of another color. So another promising engine bit the dust.

Ralph Gould, who is responsible for sending literature on the Syncro Ace, claims his engine would start on the first flip. He further states his motor was the easiest starting engine he ever owned. He enjoyed competing with Brown Jr. engine owners as he could consistently out-start them every time. The motor he owns was used in a Buccaneer Standard, a popular five foot gas design by Berkeley Models.

Produced by Syncro Devices, Inc., 743 Beaudien St., Detroit, Michigan, the engine came complete in the box with coil and condenser, the coil being a Delco-Remy. (Didn't know that General Motors built model airplane coils, did you?)

Interestingly enough, if you owned a Syncro Ace, you could get it repaired under factory guarantee for workmanship and material by enclosing 50 cents for charges! Some difference from nowadays!

For the benefit of the technically minded, the Syncro Ace was nominally rated at $1/5$ horsepower. With a bore of $7/8$ and stroke of $15/16$, the engine was a nominal .60 cu. in. displacement (actually .57) rated with a motor speed of 10,000 rpm. The aluminum engine featured a steel cylinder with aluminum piston and steel rings. Specifications call for setting the spark plug at .010 and the breaker points at .020. (The writer prefers .012 on the breaker points).

The engine collectors should be interested, as Ralph Gould has a Syncro Ace still in the box (although it has been run). Ralph says he is open for any offers, so if your stable of engines is missing a Syncro Ace, here's a chance to acquire one. Write to Ralph at 2344 Thorn Tree Lane, Ortonville, Michigan. 48462.

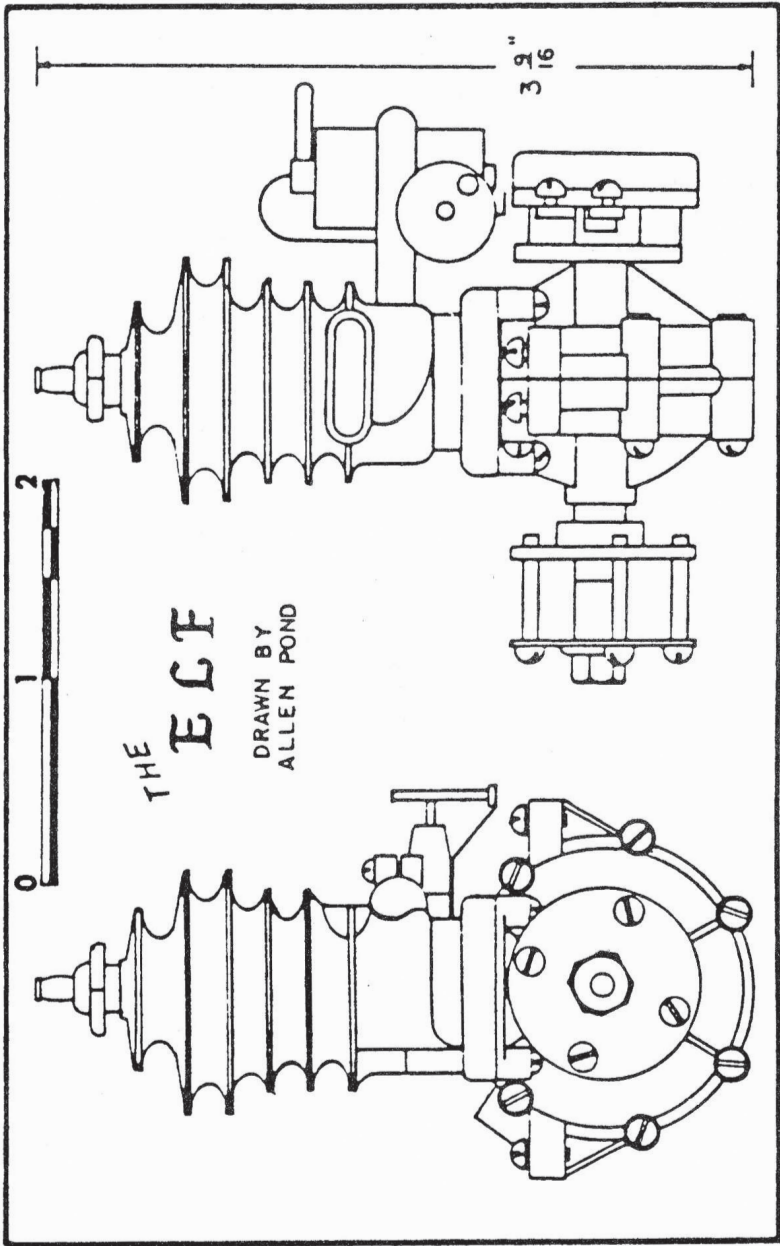

ENGINE OF THE MONTH

While Bill Brown and Maxwell Bassett were setting the modeling world on its ear with the Brown Jr., a fellow named Dan Calkins, on the West Coast, was quietly working on a small, lightweight single cylinder engine. Eventually produced in Portland, Oregon, the Elf made its appearance in late 1935.

Many of the well known early gas modelers on the West Coast, such as Joe Weathers, Don Knaption, and others, used this engine. The writer's earliest experiences with the Elf engine indicated it was anything but the claim in the Elf brochure, "the Elf engine starts easily and quickly . . ." In those early days, there was no one there to tell the new engine owner how to start and run the engine. Invariably, the engine would be primed too heavily, and then the rest of the day would be spent trying to crank the engine clear.

The Elf single cylinder engine was rated at .035 horsepower (only a 1/32 h.p.!!) at 4700 rpm. Fuel economy (the forte of the Elf engine), was 2.8 lbs per brake horsepower hour at 3500 rpm. These fancy figures mean the engine would run 40 minutes on one ounce of fuel! Whatta motor for Texaco!

Unfortunately the low horsepower output restricted the model size to three or four feet wingspan. Counting the engine as four ounces, propeller at 1/2 oz., coil and condenser and two pen-cell batteries at 3-1/2 ounces, the average Elf-powered model could be built from 12 to 18 ounces total all up weight. A remarkable achievement in those early days.

Elf engines, when first viewed, give the prospective buyer the idea the engine is rather crude, as the sand castings were never polished on the outside. Dan Calkins preferred to put his work on the inside where it counted. As a matter of fact, the machining work was so good that Dan recommended a gas and oil mixture where the oil was only SAE 40 viscosity.

One interesting fact gleaned from the Elf brochure is that the coil is designed to operate on one 1-1/2 volt

battery! However, for more reliable starting, two 1-1/2 volt batteries in series are recommended. One and one-half hour runs are claimed with this battery setup.

The float chamber (the villain in most cases of balky starting) is connected to the gasoline tank with rubber tubing. To invert the motor, the float chamber must be turned half way around on its support. This places the carburetor on one side. In the old days, Calkins supplied a reversed carburetor for those who preferred the float chamber in normal position behind the engine.

For those interested in the technical features of the Elf single, the bore was 0.542 with a stroke of 19/32 inches, giving a piston displacement of 2.25cc, or about 1/8 cu. in. The cylinder and crankcase are sand cast of heavy aluminum (Calkins states you could machine 2 ounces off the castings if lightness was essential) with the cylinder being fitted with a steel piston. The aluminum piston was fitted with three cast-iron piston rings. Tubular steel is used for the wrist pin, while the connecting rod is an aluminum casting. Interestingly enough, the two-bearing crankshaft is turned from a solid piece of drill rod and fitted with steel counterweights.

Even in those early days, a Champion Spark Plug, 1/4-32 thread, was made especially for the Elf Engine Co. Claims were made that this plug would not foul when used in an Elf engine. According to the engine manufacturer, the Elf engine could be run for over 100 hours without wearing out. A truly remarkable claim.

The Elf engine was marketed by the Elf Engine Co., complete with spark coil, condenser, gasoline tank, instruction book, and propeller, mounted on a stand, ready to run. Cost was \$21.50. That may seem cheap now, but in those days that was better than a week's pay. The writer sometimes speculates, were those really the good old days?

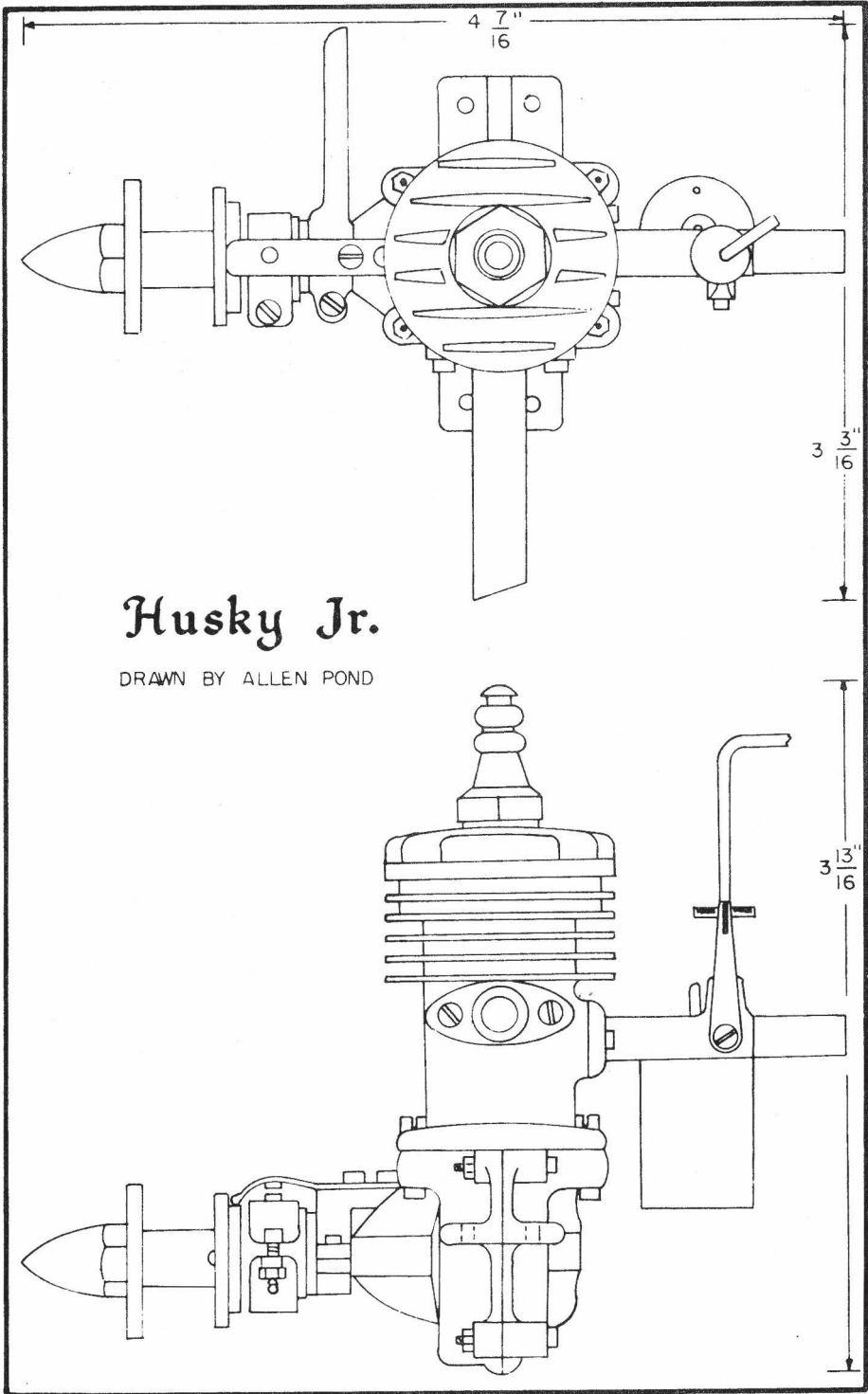

MOTOR OF THE MONTH

This month's motor derived its name from the university in its area; the Washington Huskies. The prototype, which came out in 1937, featured radial head fins, lapped piston, bolt-on bypass and exhaust. Bore and stroke of all Husky engines was .625 x .625. The early carburetor resembled the Elf float type, but the production model featured a standard intake tube and needle valve assembly.

Homer Conklin, in conjunction with a flying companion, Stuart Finely, started making motors in his basement. The success of the engines soon attracted the attention of the Douglas Model Aircraft Co. in Seattle. The production model was modified heavily to allow for sand castings all through the engine. The head was changed to the six finned type to utilize a 3/8 plug. A thin steel cylinder was fitted to a single ring aluminum piston, the metal of which was called "Vanasil". It must be noted that Conklin lapped pistons in most all of this early models.

In the September 1937 issue of Model Airplane News, the Douglas Model Aircraft Co. came out with an announcement of a new engine to be shortly forthcoming. Finally, in the November 1937 issue, a photo of the engine was featured in the advertisement. The inverted style picture (heavily retouched) was featured until the June 1938 issue, which showed the upright Husky J.V. version at \$12.50. This photo was also completely retouched.

A good photo of the Husky appears in the Modelcraft, Los Angeles, advertisement, showing the true carburetor setup. A float type carburetor (like a true carburetor) was attached to the intake tube, together with a gravity type tank on the firewall.

Just about the time that 500 units had been produced, the young designer was informed by the subcontractor that they were going to take over the entire project. Conklin, however, was able to salvage and retain the name.

The Douglas M.A. Co. decided to stay with Conklin, hence the piston manufacturing concern (to utilize their tooling setup) went into making copies of the Husky Junior, called the "BAT" . . . not to be confused with Jack Keener's "BRAT". The confidence of Douglas was soon vindicated, as Conklin, after many diligent hours in the basement, turned out another engine called the Husky Junior, so named after the Washington Husky Junior Varsity rowing team that was making such a worldwide name for itself. But that's another story!

The operating instructions for the Husky Jr. specify white gas and SAE 70 wt. oil in 4 to 1 ratio. Incidentally, for those who did not have timers to shut off their motors, the Husky could be made to run on just what gasoline was in the carburetor float valve. Motor runs of 15 to 45 seconds could be obtained by adjusting the sliding float on the needle. This, of course, after the gas line had been clamped off. With the float removed, motor runs of two minutes were possible.

The Husky Junior engine was designed for small models of 2-1/2 lb. weight. The motor swung an 11 x 1/2 inch thick propeller at approximately 7000 rpm. Interestingly enough, the flat spring type timer actually acted like a governor and rpm ratings with a propeller above 7000 rpm were hard to obtain. The later JV model corrected this fault. Husky engines were produced until late 1946, when the superior post-war designs outsold them.

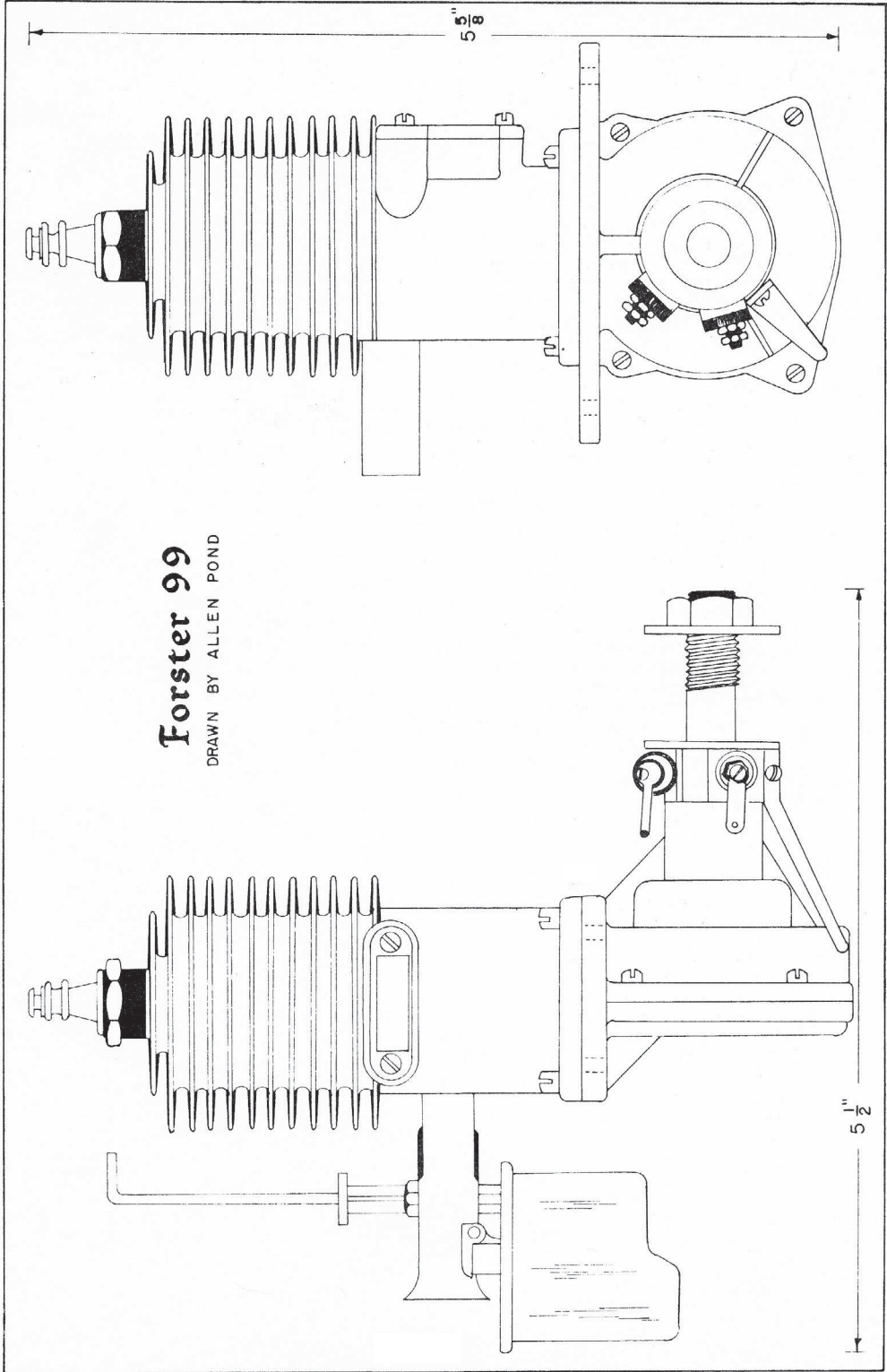

Forster 99

DRAWN BY ALLEN POND

ENGINE OF THE MONTH

The writer has been considering doing the Forster 99 engine for quite some time, and when he received the advertising brochure from M&G Engines, that decided it!

For those who are unaware of the latest developments in the proposed Forster 99 and 29 engine production, M&G Engines, P.O. Box 6026, Denver, Colorado, 80206, bought up the remaining stock of Forster parts, dies, and forms. The Forster 99 is to be retailed for \$99.50, plus \$1.50 for postage, handling, and insurance. A \$50.00 deposit will be required on each engine ordered, and orders filled in strict rotation.

The Forster 99 we are featuring this month is the later model with the large exhaust and single points (M&G informs us that dual points will be sold as an accessory). This was the most powerful Forster 99 manufactured, as the pre-World War II models featured a small exhaust and better economy.

In spite of its large displacement, .99 cu. in., Forster 99 engines were popular. Surprisingly, once you got the hang of starting, Forster 99 engines would start on two or three flips. Sal Taibi used to do it on one flip . . . if you don't count the slow pull-through the first time to choke the engine. Impressive starting qualities!

Probably the biggest drawback to wholehearted acceptance by modelers was the size and power which automatically dictated a large size model of seven to ten foot wingspan. One surprising feature of the old Forster advertisements were the recommended kits for the engine; Buccaneer, Cavalier, Oriole and their own design, a *five foot* design called the Skyrocket . . . aptly named!

The Forster 99 flying weight complete with batteries (D size cells), spark coil, etc. was 24 ounces. The motor could be run easily upright or inverted. Recommended propellers were from 16 to 20 inches (Sal Taibi uses an 18). A very effective idle (ideal for R/C) was obtained from the throttle lever supplied for those early birds wanting to try radio control.

As noted before, Forster engines were brutes for power, generating a 1/2 horsepower at 6,000 rpm. Power charts supplied by the Forster Bros. Co. showed two curves, one with standard gasoline mix, and the other based on alcohol and castor oil. Here power jumped to .70 at 7,600 rpm. Who was the purist who said alcohol was not used prior to 1938? The writer still can't understand why this standard mix was ever banned.

Before you fall over in a dead faint over the weights of the Forster 99, it only weighed 14 ounces bare. The McCoy 60 in later years weighed 17 ounces! Many of the modern engines exceed this figure without all those timer appurtenances.

For the technically minded, the Forster 99 specifications are as follows: displacement, .997 cu. in., bore, 1-1/16 inch; stroke, 1-1/8 inch; compression ratio, 8 to 1. The engine features ground and finished crankshaft, aluminum alloy crankcase with oilite bearings, timer with adjustable tungsten points, bronze bushed connecting rod, and aluminum alloy piston.

ANDERSON *Spitfire*

DRAWN BY ALLEN POND

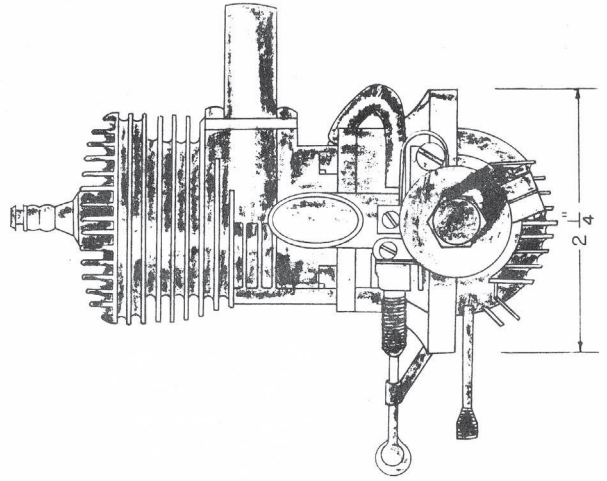
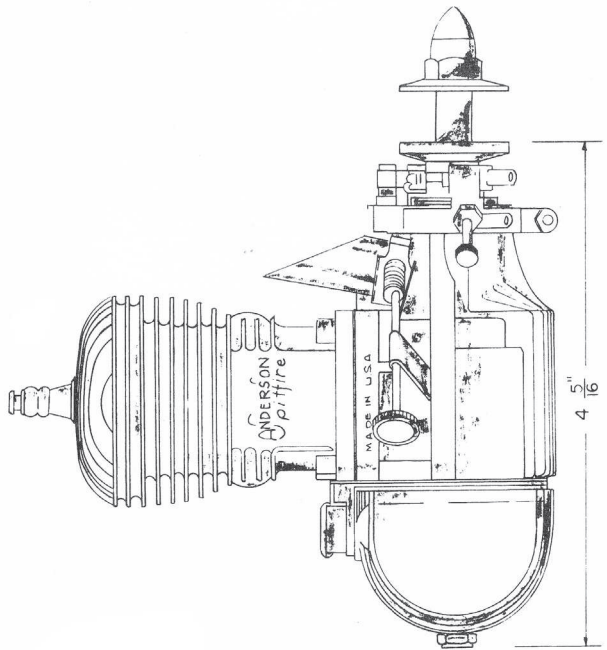
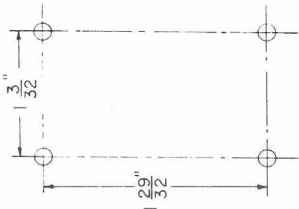

ENGINE OF THE MONTH

The Anderson Spitfire, this month's engine, was the culmination of a long series of designs by Mel Anderson. Mel, who was well known to Southern California modelers, first came to the attention of engine fans when he first worked for C.C. Moseley, of Baby Cyclone Industries (known more commonly as Aircraft Industries, Inc., Glendale, CA).

In those early days, Bill Atwood received most of the publicity, as his Baby Cyclone powered Champion won the highly coveted California State Fair Gas Event in 1935. It was in Atwood's shadow, that most modelers were unaware of Anderson's contributions to the engine designs emanating from Glendale.

During World War II, all engine manufacturing came to a stop. As a tool maker, Anderson became associated with Ray Poquette; an owner of a Brown & Sharpe equipped automatic screw machine shop. It was during this period that Mel developed the Spitfire in his spare time.

When the Spitfire first made its appearance, it contained all the features that Anderson had designed into the Super Cyclone and prior to that, the Baby Cyclone. It may be of interest to the reader that one of Anderson's outstanding contributions to the model engine world was the development of the rotary crankshaft valve. Introduced in 1935 in the Baby Cyclone, this form of fuel induction gained wide acceptance among all engine designers.

Having a successful engine design, Anderson formed a corporation comprised of three associates, Ray Poquette, Anderson, and Ace Boultinghouse, a real whiz at complex tooling setups. Known as the Mel Anderson Mfg. Co., business was initially set up at 1819 Third Avenue, Los Angeles.

The earliest advertisement appeared in the February 1948 issue of Model Airplane News, with the slogan, "The Engine Experience Built." And it was true! The engine first appeared to be an improved Super Cyclone, but on close inspection, here was an entirely new engine with features and power that would invite imitation.

Anderson Spitfires enjoyed quite a modicum of success. For radio control in the early days, equipped with a two speed timer, they proved to be unbeatable in the hands of an expert like

Alex Schneider, who still holds the distinction of winning the radio control event every time he entered the Nationals.

Spitfire engines have led a rather checkered career. After ignition engine sales fell off to the point that it was no longer practical to manufacture them, Anderson sold off all parts, dies, and castings to Bob McCord, of Redwood City. About this time, the old timer movement was starting to sweep the country. McCord, recognizing the trend, built up a following of engine collectors and flyers who wanted Spitfires.

Unfortunately, there seems to be a curse on Spitfires, as McCord also suffered marital troubles and had to sell out to Quentin Clark. Quentin immediately embarked on an ambitious advertising program and promptly found himself swamped with orders for engines.

This was totally unexpected, as Clark was a one-man operation and was unable to fill the orders, much to the chagrin of the buyers. Finally, to straighten out the mess, the entire lot was sold to Ralph Mrock (later going by the name of REMCO), of Denver, and engines were again produced in fair quantity.

Some of the dies suffered damage during all the transfers, and Mrock found he was unable to produce complete Spitfire engines after exhausting all parts. The dies and balance of parts were then sold to Karl Carlson of San Jose. Back in California once again, Carlson has adopted a cautious attitude regarding the production of engines, as the dies for the crankcases must be restored. At present, only a small selection of parts are available. For those interested in Spitfire parts, you might try Karl Carlson, at 14600 Ramstead Dr., San Jose, CA 95127.

For the technically minded, the Spitfire engine featured a bore of 15/16, stroke of 7/8, with a compression ratio of 6 to 1. Displacement was .64 or .604, depending on the particular version you have; the fitted piston being the smaller bore, while the ring job is rated at .64 cu. in. displacement. Crankshaft was machined from SAE 3140 steel stock. Interestingly enough, the shafts were not centerless ground. All engine castings, cylinder head, cylinder, exhaust manifold, crankcase, rear cover plate, and timer plate were made of aluminum. Engine weight was 12 ounces. Recommended propeller size was either 13-6 or 13-8.

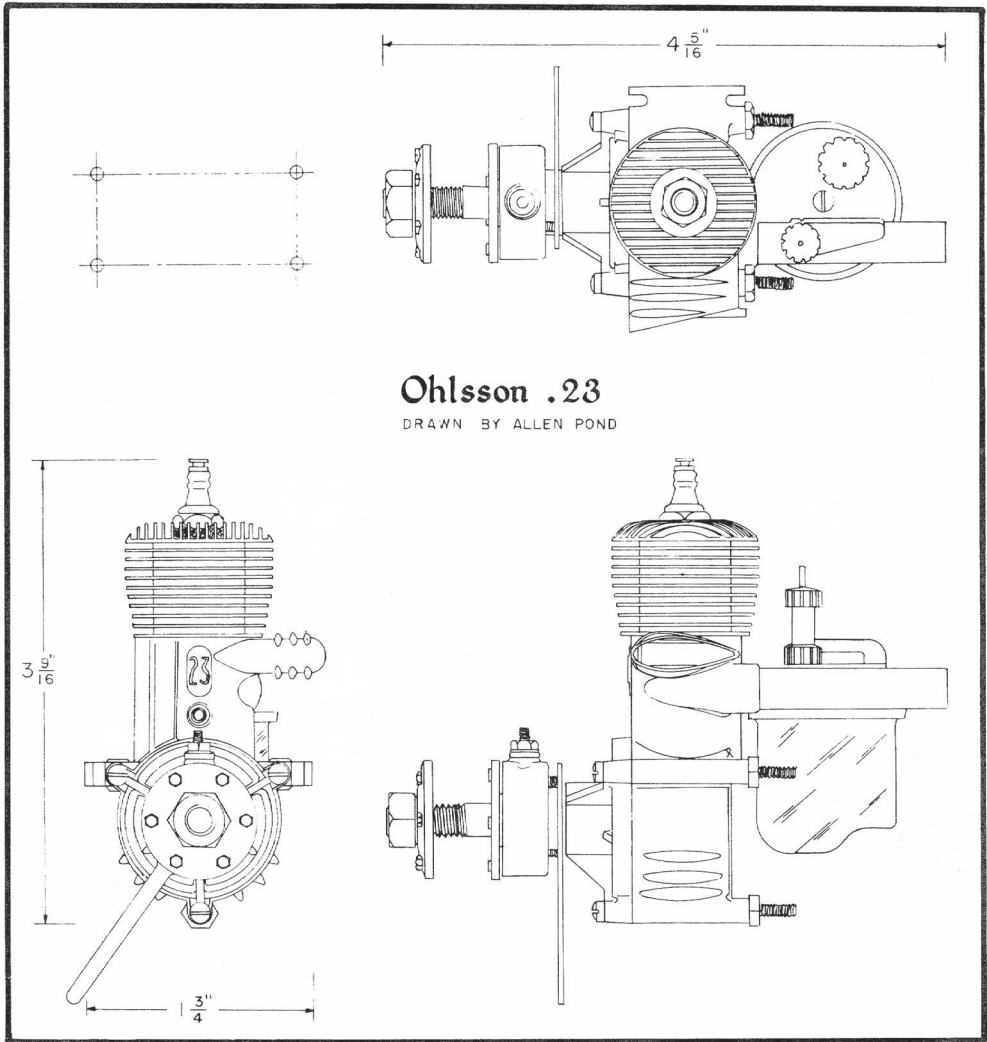

ENGINE OF THE MONTH

This column has run drawings of the early Ohlsson engines (Miniature and Gold Seal), but the engine that put Ohlsson on the map was the incredible Ohlsson 23.

First introduced in the September 1938 issue of Model Airplane News, this engine was a sensation. Here was a small motor that would start and run *reliably*. Ohlsson engines were so straightforward in starting, any newcomer to the game could operate the 23 with very little trouble.

For a little background, Irwin actually ran a contest to name his new engine. Wouldn't you know it, after numerous ideas and names, such as "Ora," "Zip", and "Whiz", he finally settled on the most logical name, the Ohlsson 23. In later discussions with Ohlsson, he freely admits the Ohlsson 23 was his real "bread-and-butter" engine. Exact quantities of production engines are a little nebulous, but by the time World War II arrived, over 50,000 had been produced!

Ohlsson introduced an innovation in engines when he spot-welded the cylinder with a die-cast aluminum crankcase that featured an integral exhaust stack and intake tube. The cast aluminum front cover (which was the only way to get the piston and conrod out) was bolted to the crankcase. Interestingly enough, this front cover included the bronze main bearing and ball bearing thrust washer.

It was this simple arrangement that allowed Ohlsson to produce the front rotary valve conversion which ran much more powerfully than the original three-port arrangement. This postwar addition was regarded as a stopgap by most (and even by Ohlsson), as the Ohlsson 29 and 33 were engines designed specifically for the front rotary valve crankshaft.

As noted before, the cylinder and cylinder head were machined from one piece, the inside being "blind" bored to size. Interestingly enough, where the Ohlsson 60 had a cast iron piston, the Ohlsson 23 featured a stamped steel type. In talking about this unique engine, a prospective buyer of an old Ohlsson

23 would do well to look carefully at the spot welded connection between cylinder and the crankcase. Any looseness here indicates an engine with trouble.

Ohlsson engines were modified slightly over a ten year period; the most obvious external feature was the elimination of the beam mount lugs on later models. Of course, many modelers, accustomed to mounting their engines this way, finally forced Ohlsson to issue a set of stamped fittings that served to mount the engine on beams.

When the Ohlsson 23 first made its appearance, it turned 7,200 rpm on a 10x4 prop. This was an exciting advance for small engines, and popularized the Class B event to the extent that practically every kit of that era showed an Ohlsson 23 in its nose. It wasn't until years later, when the Class displacement size was set at .29 for Class B, that the Ohlsson found itself outstripped for performance in its class by the .29 engines. Almost a case of rules changing the engine off the market (we don't do that today, do we? Haw!) (*No, we don't! wcn*)

For the technically minded, the Ohlsson 23 featured steel tubing wrist pins, and a die cast connecting rod with a bronze bushing at the lower end. The carburetor and gas tank being attached to the intake tube, made a convenient and neat method of keeping a model from becoming oil soaked.

The enclosed timer, a feature originated by Ohlsson, had a pressed steel housing. Timer points were readily accessible, and could be easily adjusted by screws on the timer housing. Probably the only weak link was the floating point system, which sometimes lost a point as these were simply spot welded. In all fairness, it must be noted that Ohlsson timers were quite trouble-free, particularly when compared to other engines of its time.

Ohlsson 23 engines were what the name implied, .23 cu. in. displacement, with a bore of 11/16, stroke of 5/8 (this became practically a classic standard!), with a weight of 5-1/2 ounces. We'll never forget this engine!

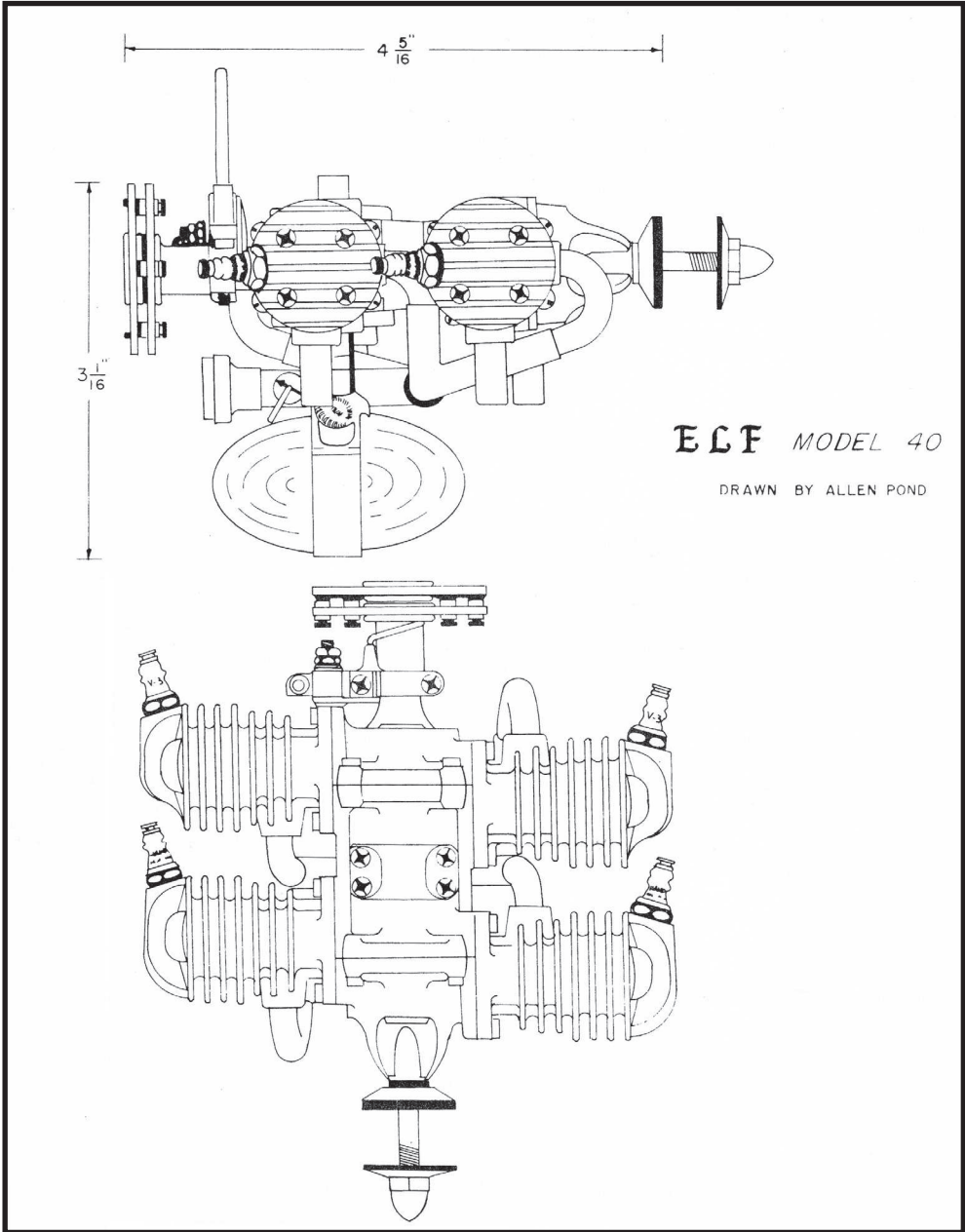

ENGINE OF THE MONTH

When Dan Calkin started producing ignition engines, it was in the usual practice of the day; single cylinder, long stroke, and emphasis on economy. These features were dictated by the event(s) of the day, wherein a ration of fuel was given per unit weight of the model.

The single cylinder Elf (as reported in the November 1976 Model Builder) could run 40 minutes on an ounce of fuel! However, the power output was only about 1/32 H.P. With the limited engine run rules starting in 1938, the whole concept of engines changed. The emphasis was now on power and the ability of the model to gain maximum altitude in the allotted time.

Rather than abandon a proven design, Dan Calkin (an ingenious fellow) decided the easiest way was to use what he had and make a twin out of the single to give a displacement of .198 to coincide with the new engine classification; A, B, and C.

The twin was a more powerful Class A engine. Calkin immediately decided (based on the success of the twin) to just keep hooking up engines in tandem until he had an engine for each class. His four cylinder Elf (this month's subject) gave him a small class C engine, while the six was the top of the line for Class C in the 60 range.

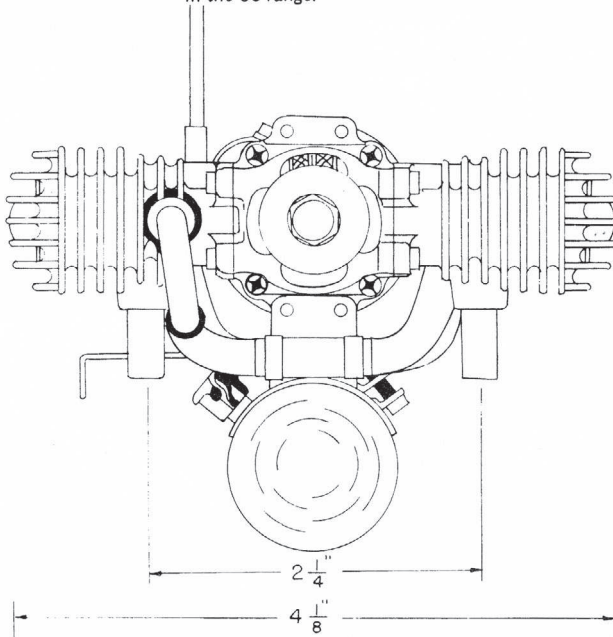

As was to be expected, all parts of the four were interchangeable with the single, with exception of the crankcase, crankshaft, and gas tank. We lost track of the number of ball thrust bearings, but we do know there was one twelve-ball bearing in the twin! Interestingly enough, all Elf engines were designed (according to the brochure) to run as well on the hundredth hour of operation as it did on the first!

Of course, this was based on the premise the engine would be kept clean. To help this problem, the Elf engines were equipped with a filter to remove dust and prevent dirt from getting into the engine. In addition, because of the number of cylinders, vibration was considerably reduced, with consequent smoother running and lower wear. One of the other claims made by the manufacturer was the ability to run cooler. For this reason, Calkin recommended nothing heavier than SAE 40 oil. This, of course, gave the economy claimed.

The Elf Four, as marketed by Calkin, sold for \$64.50, complete with coil, condenser, and brackets. The engine was guaranteed to give satisfactory performance in every way. Don't you wish you could catch today's manufacturers doing that!

For the technically minded, the Elf Four displaced .396 cu. in. (double of the twin at .198), bore 15/32, stroke, 9/16, all pistons made of forged aluminum, with aluminum cylinders and crankcases. The Model 40 (as it was called) weighed approximately 10 ounces bare. Flying weight, with coil and condenser, propeller, etc., ran close to 14 ounces, a fairly heavy weight for a small Class C engine. (Brown Jr. weighed only 6 ounces bare). The price was another reason for limited sales, as this type of engine only appealed to the specialty modeler.

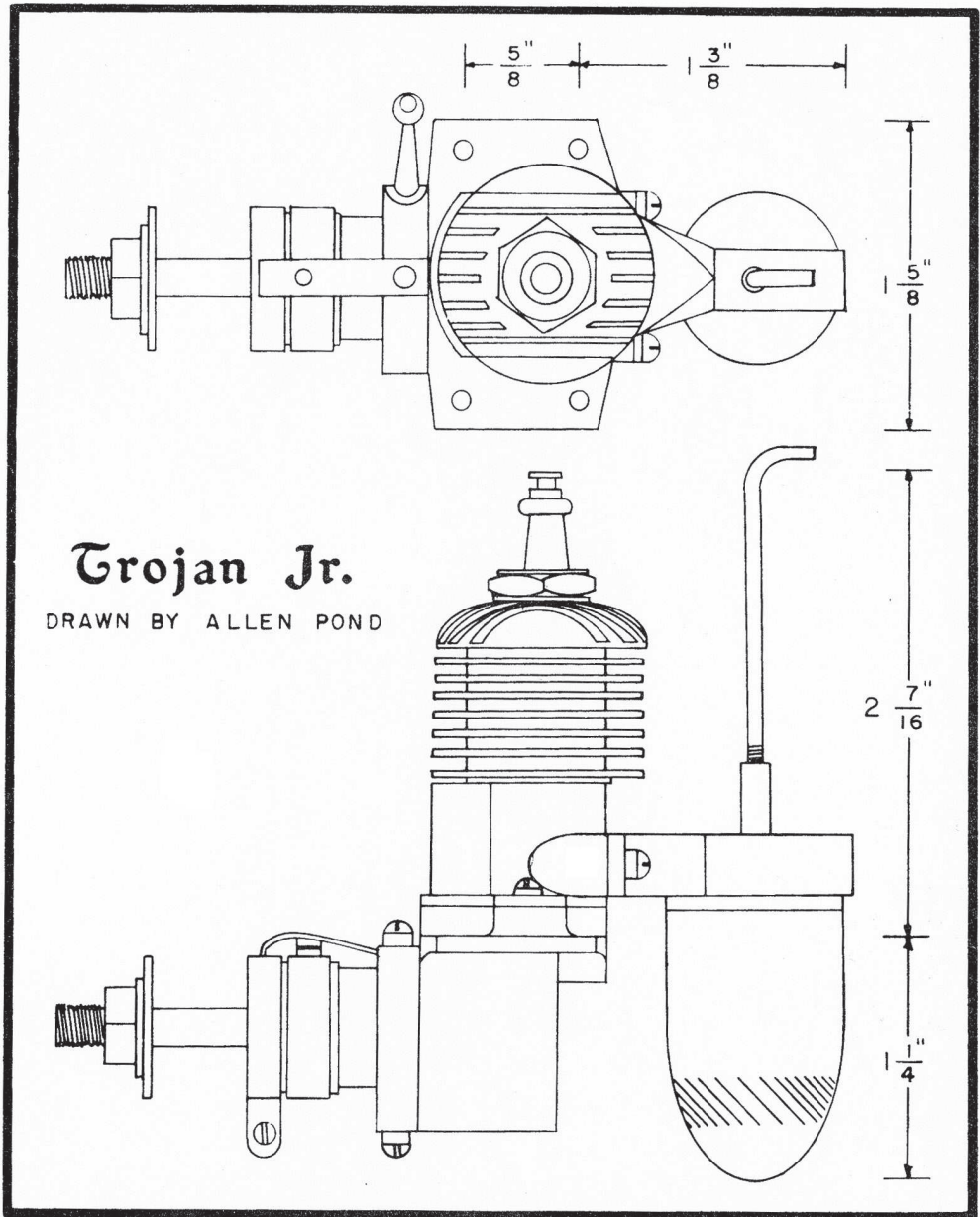

ENGINE OF THE MONTH

Thanks to Bill Caldwell of Dallas, Texas, I am finally able to oblige my Czech friend, Bill Krecek, and provide a writeup on the Trojan engine as manufactured in the Los Angeles area by Hal Atkins.

The Trojan engine, although good for its day, was one of the engines that got swallowed up when the Ohlsson 23 made its appearance. As noted previously in the Ohlsson article, the 23 was such an easy starting small motor, it just naturally ran (a pun!) everyone off the market.

However, in examining the Trojan engine, which had roller bearings, here was a neat little engine. Claims of one pound of thrust using a nine inch prop were not to be sneezed at. A 12 ounce flywheel (for boat operation) would assure a range of 500 to 15,000 rpm.

Like all the predecessor of the Ohlsson 23, models weighing from one to two pounds were the limit for this motor, if performance was to be expected. Of course, the Ohlsson 23 operated best with models in the 25 ounce range, but with proper care, the Trojan could be competitive.

Probably one of the very few things that most people don't know is that Hal Atkins produced a 90 size motor for experimental designs, radio control models, helicopters, generators, and you name it. However, the engine weighed 21 ounces bare, hence the problem of competition with the Forster 99 motor which was considerably lighter and gave better power.

The Trojan Junior, as it was called, featured a 5/8 inch bore and 5/8 inch stroke, giving a rated 1/8 horsepower. The cylinder, made from cast iron and ground to .0001 tolerance, was attached to the crankcase with only two bolts. The fins were 17 ST dural. The cast iron piston came with a solid skirt and four oil grooves. It was claimed this prevented fouling when the motor was inverted.

The wrist-pin was manufactured from tool steel allegedly locked in place by an exclusive method we have been unable to determine. Connecting rod was machined from solid stock Tobin bronze, while the crankshaft was standard heat-treated steel, ground to size.

In the aluminum sandcast crankcase, the precision roller bearings for the crankshaft were installed so as to give an exclusive method of sealing (Press fit would be the answer). Interesting enough, the gas tank was made of Dural 17ST, threaded to the intake tube. This made for easy removal of the tank for cleaning and/or refill (no Gits filler cap).

The Trojan Jr. came ready to run, mounted on a hardwood block with coil, condenser, and hardwood propeller, ready to run for the princely sum of \$18.50. Although Trojan motors were quite popular in the Los Angeles area, they are quite difficult to find now. The writer often wonders how many of these motors are still in someones attic or basement. Just a question of rooting them out.

Tiger Aero

DRAWN BY ALLEN POND

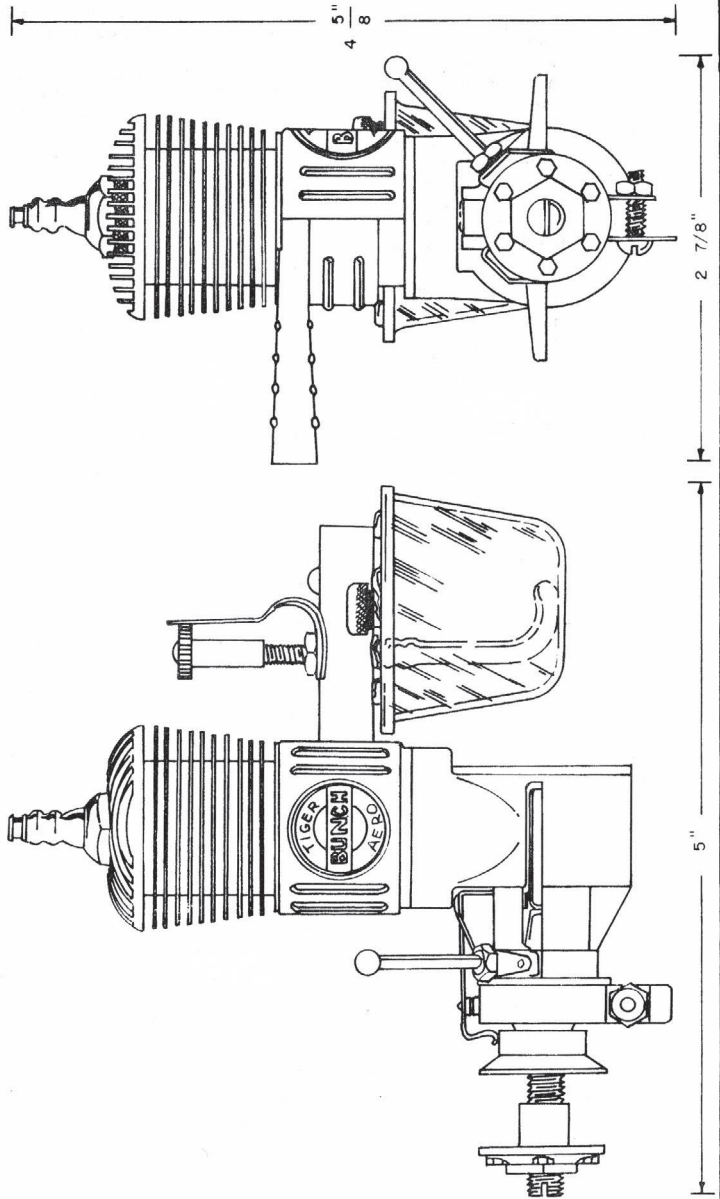
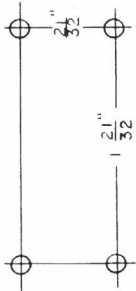

ENGINE OF THE MONTH

In the early days (as today), California and particularly Southern California, was a hotbed of modeling activity. With such a tremendous interest, this served as an excellent development and test background for weeding out the engines that simply didn't have it.

Among the more successful engines in the south, were the series of motors put out by Bunch Mfg. Co. This month's motor, the Tiger Aero, was probably the culmination of development by Danner Bunch, as it was an excellent ringed engine.

According to the brochure issued by the Bunch engineers (Broughton, Bunch, et al), extra performance was obtained by using ethyl or high octane gasoline. With a compression ratio of 7-1/2 to one, the recommended fuel was 16 ounces of ethyl gasoline to 8 of castor oil, with one ounce of ether to make the ingredients blend (Acetone also has the same effect).

Modelers would do well today to review this mixture, as several of the "hot dogs" are using this combination with excellent results. Of course, they are not running around telling everyone their secret. Also, they are going this combination one better by using 3 to 1 and 4 to 1 mixes, utilizing "Blenzoil" for lubrication (Blenzoil is available at your local motorcycle shop).

The Bunch people found better lubrication at the main bearing could be obtained by cutting a spiral groove in the bronze bearing. This effectively gave a force feed (from the crankcase pressure) resulting in better lubrication and smoother running. This resulted in claims of .44 horsepower at 8500 rpm, using a 12 inch propeller. This approached the magic figure (in those days) of one horsepower per cubic inch of displacement.

With the introduction of the Tiger Aero engine, the Bunch Company launched an intensive advertising campaign, with one full page being devoted to reports of winners using Tiger engines.

My good friend and bosom buddy, Charlie Werle, was responsible for popularizing the use of Tiger motors in Jim Walker Fireballs (normally equipped with Ohlsson 23 engines), when he scored a clean sweep at the California State Fair Championships, winning the precision, speed, and acrobatic events. The writer was lucky to be present and aid in the victory. No question about it, the Tiger Aero engine in a Fireball made a great performer out of this Jim Walker design.

Of course, it didn't hurt a bit when Bud Warren and Dean McMillan won the speed and acrobatic championships, respectively, at the First Official Speed and Acrobatic Competition for Controlled Gas Models at the Lakewood Stadium in Long Beach, in July of 1941. Also about this time, the Bunch engineers assisted Dean DeGonia in setting a World's Endurance Record of 3510 laps at the Southern California Gas Model Airport (sometimes called Gotch Airport). In short, the Bunch people were busily pushing a good product and a new fad, controline flying.

Bunch Tiger Aero engines were officially announced in the June 1940 issue of Model Airplane News, priced at \$16.50. A ten-page catalog, costing 20¢, titled "Bunch Gas Model Engines", was offered to all modelers interested in updating the performance of their engine. Of course, being a Bunch publication, the emphasis was on their products, but, by and large, a good number of facts could be gleaned from the booklet.

Interestingly enough, one of the early cartoons in the Bunch Co. advertisements depicted another modeler trying to start a motor saying, "I wish he'd shut off that screaming Tiger. We can't hear our engines run." Believe it or not, that saying has persisted to this day about a "screaming tiger". However, this has degenerated to include about any hot running motor that makes a lot of noise.

For the technically minded, Tiger Aero engines featured a bore of 7/8, stroke, 3/4, and overall height of 4-1/4 inches. Cylinder and head was steel, with the intake, by-pass, and cylinder manifolds welded to the cylinder to eliminate the faults and leaks resulting from bolted parts appearing in the early Ohlsson and Baby Cyclone motors. Displacement was .45 cu. in., with a nominal rating of 1/5 to 1/4 horsepower. As noted previously, more horsepower was obtained with correct combinations of propeller and high octane fuels. Bunch was also one of the first manufacturers to introduce a small ignition coil which later lead to the successful Aero Spark Coil (no relation between companies).

Brownie

MODEL E

DRAWN BY ALLEN POND

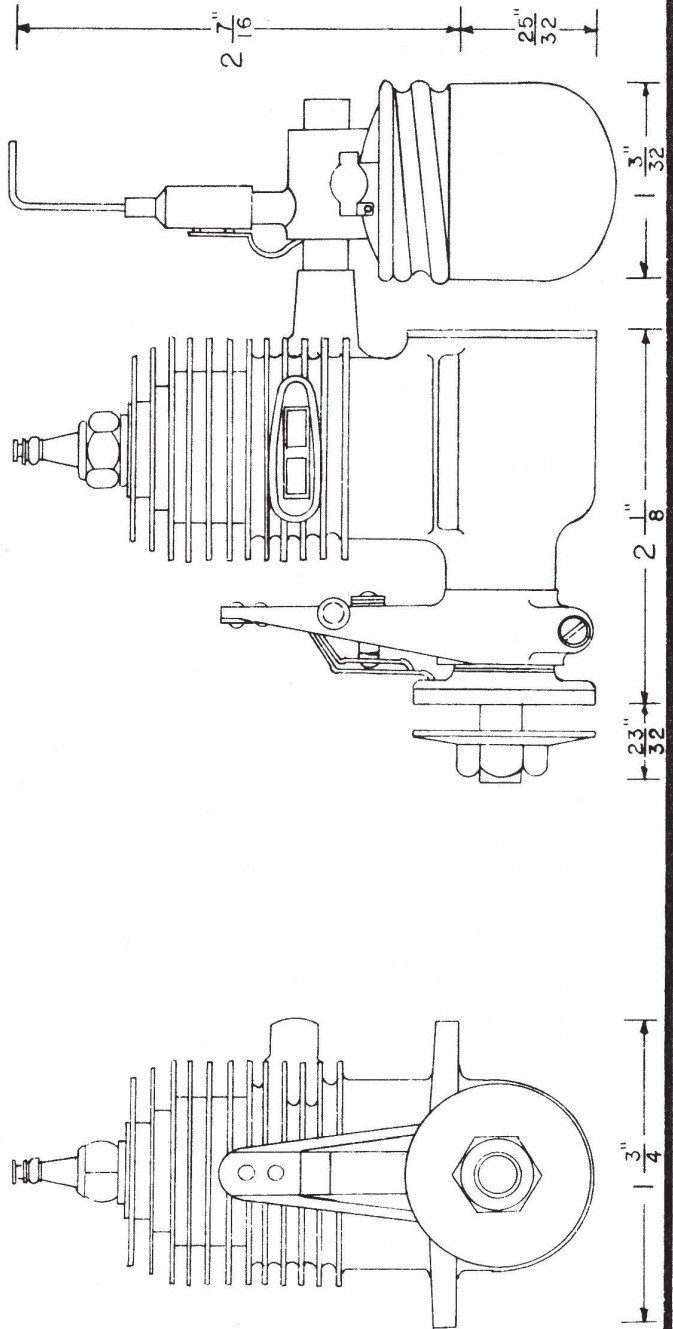
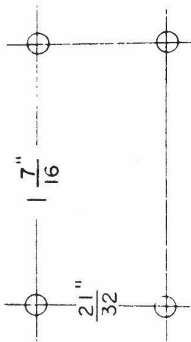

MOTOR OF THE MONTH

This month's motor is the Brown Model E, commonly called the "Brownie". This was the last motor manufactured by Junior Motors Corp.

The Brown Model E was conceived as an answer to the extremely popular Ohlsson 23, as manufactured by Ohlsson & Rice. With production figures running over 50,000, E.J. Roberts decided it was time for his company to try and cash in on the exploding small engine market.

Attractively priced at \$7.50, the Junior Motors Company had high hopes for large sales. Such was not to be, as Bill Brown, employed at that time only as a consultant, warned against rushing an unproved motor into production.

Initially the engine sales were good, but as the modelers tried for performance it was then obvious the engine fell far below its estimated capabilities. The hoped-for shot-in-the-arm sales from the Brownie engine failed to materialize, and the whole line of engines suffered accordingly.

Actually, the Brownie was a .29 size cu. in. displacement, despite its small appearance. The manifolds and crankcase were cast as one piece, with a built-in streamlined exhaust stack. According to advertisements of that day, the one piece steel cylinder embodied a locking device whereby register between port openings and the crankcase manifold is automatically secured.

The crankshaft was made of chromemoly steel, drop forged, heat treated, and ground to size. The main bearing surface in the crankcase was broached and burnished. The timer (where trouble developed) had so-called "pressed" contact points rather than sprung. It was alleged this system eliminated carburizing or pitting of the face of the tungsten points. Needless to say, problems immediately developed.

For the technically minded, the Brownie featured a bore of .770, stroke .625, which gave this three-port engine a 1/7 hp. rating at 5200 rpm, employing a 10 in. dia. 7 inch pitch propeller. Fuel mixture was the same as recommended for all Brown Jr. engines; three parts of low test (white) gasoline to one part of SAE 70 wt. oil.

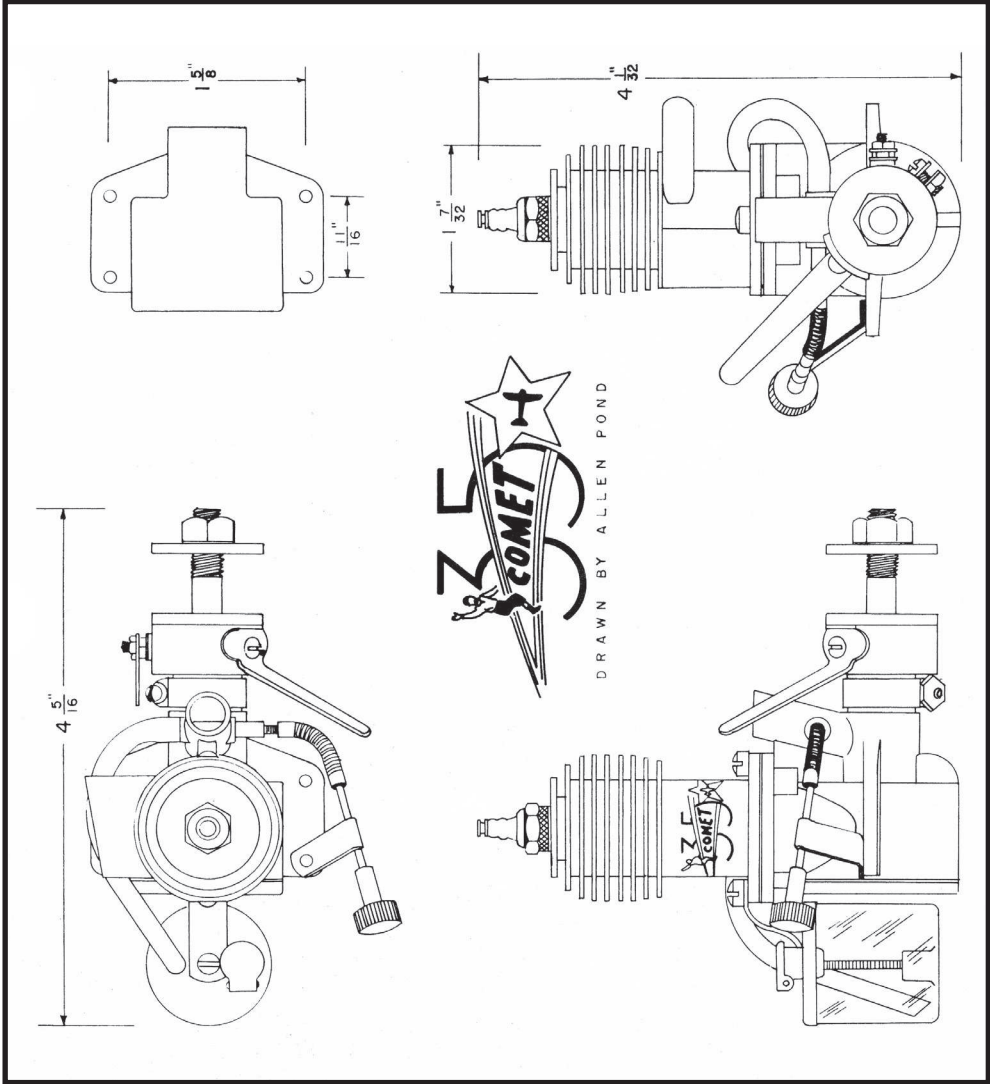

ENGINE OF THE MONTH

With the Zipper enjoying unprecedented sales, the Comet Model Airplane Co. started looking around for a suitable power plant to complement this most successful design. They found their answer on the West Coast, where the designer of the Brat engine lived.

Jack Keener, when contacted, agreed to design and develop a small Class C motor suitable for Comet products. In less time than it takes to describe the action, Keener had a motor ready for production. Comet immediately launched a full page advertisement in the May 1941 issue of Model Airplane News.

The motor, with a .35 cu. in. displacement, was rated at 1/5 horsepower at 6500-7500 rpm, using a 13 inch propeller. Strobotac tests gave a 45 oz. thrust. The engine was advertised at \$12.95, complete with Smith coil, metal-clad condenser, deluxe run-in block, and a Motor Manual. A full guarantee was given with each motor.

Interestingly enough, the recommended 13 inch propeller turned out to be another Comet product called the Comet "Airspeed 35" propeller. You could get the prop in a variety of conditions. At 35¢, you received a hand rubbed and polished glossy prop. For 25¢, you received a finished and lacquered propeller. If you weren't too flush, you could buy the Airspeed 15 at 15¢, which was only partly finished and unlacquered. Props were also offered in other sizes ranging from 8 to 14 inches.

Keener, who did considerable work for Mr. Hurd, of Electro-Spray Corp., contracted to have the Comet 35 produced. With initial sales soaring, the Comet people were delighted and requested more money. Keener, by this time, was feeling the pinch of his investment and requested some back up money. As Jack said in an interview, they gave me everything (compliments, etc.) but money.

Faced with no other alternative, Keener sold out to Electro-Spray and they produced a few more Comet 35 engines. Some old story. Comet was so badly overextended with all the new products they were bringing out that money was hard to come by. Eventually,

Hurd ceased producing the Comet 35, and in conjunction with Earl Vivell, a San Francisco distributor/dealer, started producing the engine under the name of Vivell during the war years. But that is another story we'll tell you later on.

Keener's shop was located at East 17th and 29th Avenue in Oakland not far from Electro Spray. Some engines were produced at this plant, but in very limited quantities. With the war coming on, and its attendant shortage of materials, the engine design was sold to Hurd.

Actually, the Comet 35 wasn't a bad running engine, and would have made an excellent Class C version of the Zipper. However, this was not to be, and Earl Vivell cashed in on the design.

For the technically minded, the cylinder was machined from solid bar stock alloy steel. The piston was cast iron, honed and lapped for individual cylinder fitting. Crankshaft was hardened alloy steel. A special bronze alloy featured the wrist pin, with extra large bearings for the connecting rod and wrist pin.

A transparent gas tank was provided. Exhaust manifold was brazed to the cylinder, while the main bearings were bronze. Two gaskets were used in the engine to eliminate compression leakage.

According to the engine brochure, the engine would not overheat due to its large cylinder fins. Recommended fuel was three or four parts of white gasoline to one part of SAE 70 wt. oil. Bore was .765 inches, with a stroke of .763, making it practically a "square" engine.

The writer is indebted to Karl Carlson (who produced Kiener Brat engine replicas) for the information available on a taped interview with Jack Keener. It was truly a shame that Earl Vivell suffered such an unexpected heart attack before he could be fully interviewed on the Vivell engines he marketed and sold through his distributorship.

Golden Eagle

DRAWN BY ALLEN POND

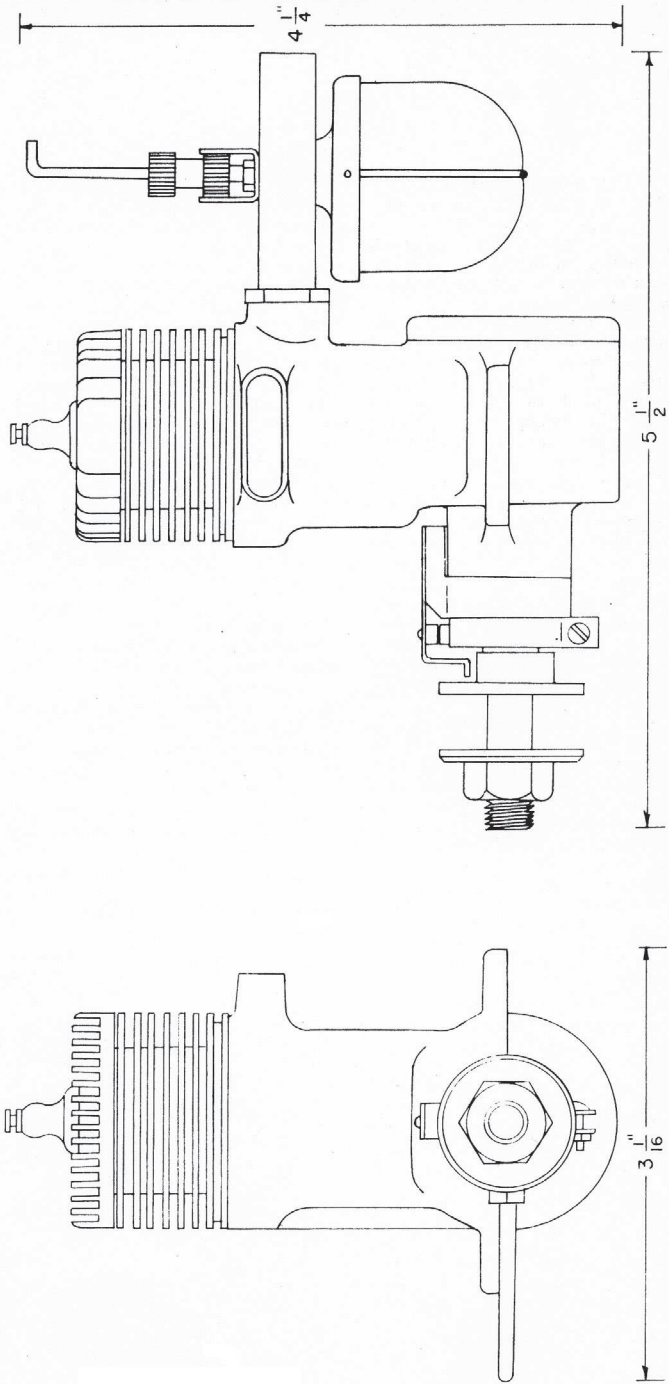
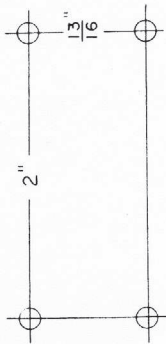

ENGINE OF THE MONTH

Or . . . How to build your own production engine, in one million easy steps! That's about how we should title this month's engine, the Golden Eagle, as developed, manufactured, and marketed by Karl Spielmaker.

As Karl reports in his letter to this columnist, the engine started from a joke. Starting as a fun project, it deteriorated rapidly. Actually, after completing a batch of Dallaire Pee Wee engines, a couple of his modeling buddies (over a few beers natch!) suggested that Karl develop an engine that would look and run like an old timer. Use ideas, but no copying; this engine must have its own personality.

"It's amazing what you can get committed to over a few beers" sez Karl, and he found himself searching through the old magazines for ideas, i.e., a brass tube intake (that'll give it color), a clear gas tank, and of course, a brass timer arm that will be in plain view. After a few sketches, the engine started to fall into place.

Finding a name was something else. By sheer chance, Betty (his wife) and Karl were dining out one evening at the Fred Harvey Golden Eagle Restaurant. Pow! The name hit Karl right between the eyes. Golden Eagle! That was it!

Design problems were numerous, but thanks to help from fellows like Bob Pattison, Bob Reuter, Tim Dannels, and Wayne Cain, the problems didn't seem so insurmountable. Karl recalls some of the more outstanding ideas, such as putting wire under the gas tank (ala Arden) to hold it in place, a brass intake tube so it would break off easily, and a molded tank from clear plastic.

Having now made up the final drawings and doing his own castings, Karl recalls well the help he got from Bob Pattison and Bill Driftmeyer on the machine work. The castings turned out fine and the cylinder was hogged out of

cold rolled steel. A point assembly was cannibalized from one of the Pee Wee engines on hand.

First trials with the engine were great. Started easy and did 4,000 rpm on a 12-6 propeller. Something wrong! Problem was traced to a piston with no baffle. A small piece of aluminum (similar to the trick used on the Rocket engine) bent and bolted to the piston top helped subsequent running. Engine still would two-cycle. Answer; the fuel timing was off on the intake. In side-port engines, the bottom of the piston acts as the intake valve. Problem was blowback with fuel going both ways.

With this problem solved in the 2nd and third prototypes, the rpm jumped to a range of 5750 to 6000 rpm on a 12-6 prop. Time to place an ad in the Engine Collectors Journal announcing the new engine.

If Karl thought the R&D stage of the engine was a headache, the production problems really compounded his troubles. Karl found by producing the small parts first he could exercise better quality control and spot troubles quicker. A run of 6 to 15 engines at a time was standard practice.

Time was the biggest factor. Karl found out there were 32 items involved in the production of each engine, from the prop nut to the shipping box. Karl received a liberal education in tooling, fixtures, and methods to make each part. As an educated guess, 283 machine operations were involved to produce one engine. An outstanding example was the crankshaft, requiring 23 operations.

Of the original 6 to 8 engines, machining problems developed in the crankcase casting at the cylinder connection. Boring for the cylinder cut into the threads for the rear crankcase cover, causing leaks and reducing power. A new and larger crankcase casting was made, which eliminated the long tall look that characterized the first models.

Additional work was eliminated by making the crankshaft a 3-piece silver soldered assembly. Hogging out from solid material was entirely too time-consuming. In 1973 and '74, some changes were made to the piston length and compression, to the point where the engine would now turn 7500 rpm with a 13-6 prop. Not bad for a .53 cu. in. sideport engine!

Timewise, the first engines represented 12 hours. The later engines (the learning curve improves things) showed a drop to eight hours. Karl is still making changes to cut machine operations and save time.

For the technically minded, the Spielmaker Golden Eagle has a bore and stroke of 7/8 inch, giving a .53 cu. in. displacement. Piston and cylinder are cast iron with an aluminum rod. The cylinder receives a bright gold anodize finish, and the fins are painted gloss black. Engine weight is 13 ounces, and is provided with a special decal in the box.

Spielmaster has produced 50 engines in eight years. Some kind of a reverse record when compared to the original production records in 1938. Most Golden Eagles are on collector's shelves. However, several have been used, notably by Tim Dannels, during the early Old Timer Champs at Denver.

Ed Rangus, of the old Chicago Hot Heads, used one in a Shereshaw Cloud Cruiser for the Texaco Event. It was the writer's personal opinion that the engine ran somewhat like an Ohlsson 60. If anyone is interested, engines cost \$75.00, and can be purchased from Spielmaker Engines, 3153 Burlingame S.W., Wyoming, Michigan 49509. A deposit of \$25.00 is required and the waiting period is between 6 to 10 months.

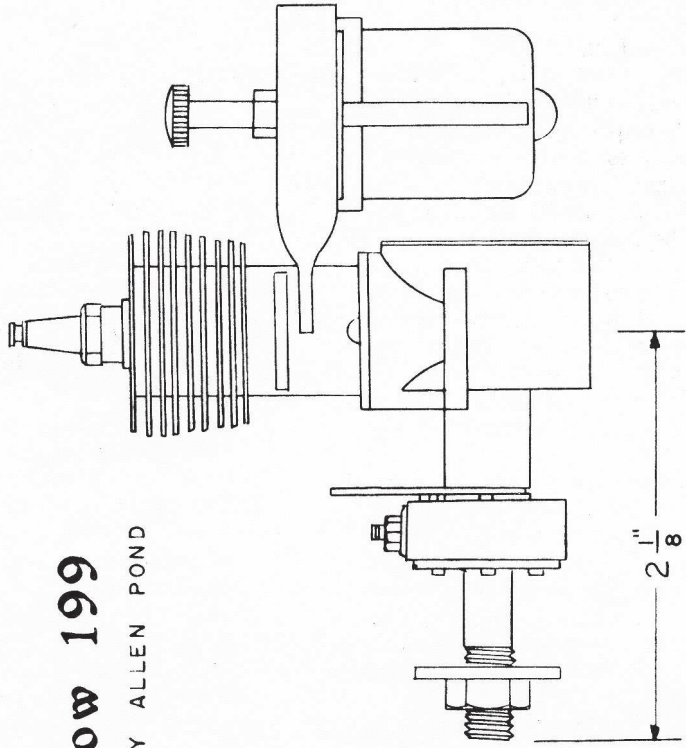

Megow 199

DRAWN BY ALLEN POND

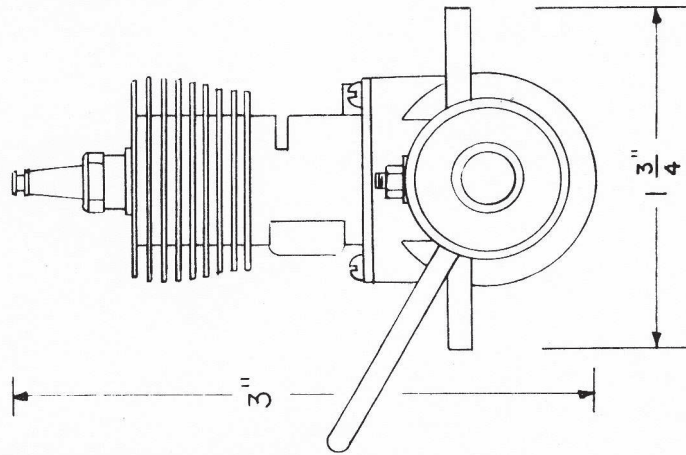

ENGINE OF THE MONTH

When the Comet Model Airplane Co. came out with the Comet 35 engine to complement its Zipper, Fred Megow was not to be outdone and introduced a new engine called the Megow 199, made specially for use in his Megow Ranger.

When the writer was the first on his block to procure one of these engines, he received a definite shock on opening the box. The Megow engine appeared to be quite lightly made, giving the appearance of weakness throughout the cylinder and crankcase.

Fred Megow really took on some tough competition with his engine, as there were already two well-entrenched .19 motors: Bantam and Ohlsson. After the initial sales, that found the modelers comparing performances, the engine was quickly abandoned as sales dropped to a small trickle.

The initial impression one gets of the Megow 19 is that every corner that could be cut, was done in the interests of a cheap engine. The exhaust port was simply milled in the side of the cylinder and no exhaust stack provided. The needle valve, reminiscent of the Brown Jr. Model D "nail valve", was also lacking in fine control.

On the plus side of things, the timer was enclosed ala Bantam/Ohlsson style. This was surprising to the new owner, as exposed type timer points could be made for less. The

bypass was a simple bulge, welded to cylinder to provide for full transfer from the crankcase.

The original brochures of the engine claimed speeds of 2,000 to 10,000, but the writer was never able to realize better than 8,000 rpm. The engine was extremely light, weighing only 3 ounces bare. A very lightweight Ranger could be built with this motor. However, the engine was never that reliable in starting characteristics.

For those interested in the technical details of the motor, the overall height was 3 inches with a 1-3/4 inch width and length of 3-3/4 inches. A transparent plastic tank was provided, along with an extra-long spark advance arm, made, of course, from stamped metal.

Specifications of the engine revealed a bore of 5/8 inch (seems like everyone used this size!) with a stroke of 5/8. The recommended propeller was a 9 inch dia. by 3 inch pitch. Not counting the propeller, the entire engine weighed 6-1/2 ounces. Stripped of the tank, bare weight was three ounces, as mentioned previously.

In summary, one could say, here was an attempt to produce a lightweight, cheap engine; but the quality featured in competing engines was entirely missing in this engine. For that reason, Megow 199 engines have turned out to be quite a collector's item.

HERKIMER
O.K. "49"

DRAWN BY ALLEN POND

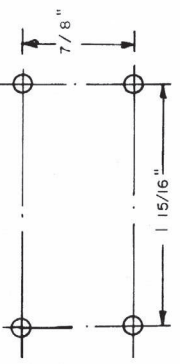

MOUNT LAYOUT

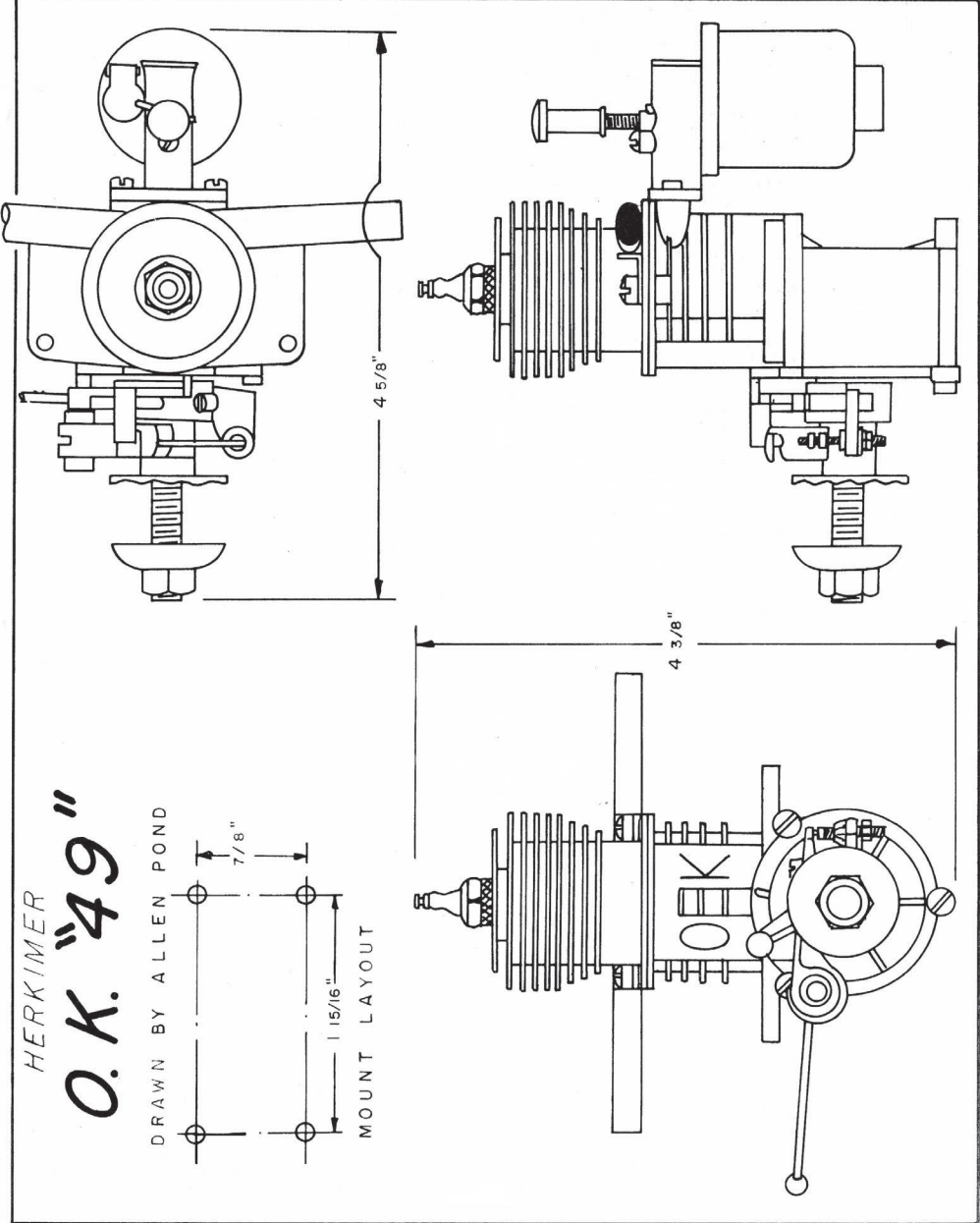

ENGINE OF THE MONTH

A lot of old-time modelers never realized that there was such an engine as the OK 49. This motor, due to its slightly lower power output, was responsible for a considerable number of designs in the five foot wingspan size appearing in the 1941 model magazines.

To back up a little, the gas engine craze was in full swing by 1939, and there was plenty of competition for the market from Brown, Super Cyclone, and Ohlsson. A definite overhaul was in order for the present line of OK engines, and Charles Brebeck proved his ingenuity as a machine man.

In 1940, Brebeck came out with a new look on his engines, while keeping most of the basic parts unchanged. He announced an OK Deluxe (.616 cu. in. displacement), OK Standard (.604 cu. in.), the OK Special (also .604), and the OK 49 (.493 displacement). There was a price for every pocketbook, with the Deluxe starting at \$19.50 (strangely enough, if you wanted it inverted, this was \$1.50 extra), followed by the Standard at \$16.50, the Special at \$12.50 and the OK 49 at \$12.50. Almost a carbon copy of the Junior Motors Corp. of scaling prices on their Brown Jr. models B, C, and D!

Three-view drawings show the cleverness of the engineering at Herkimer Tool & Model, as all of the above engines had interchangeable parts. A commonality of this type allowed Brebeck to drop his prices so as to match Super Cyclone, which was then a strictly mail-order engine at a very competitive price.

To really round things out, the Herkimer concern offered a Raceway and Marine engine takeoff on each of the foregoing engines, in an attempt to capture the car racing and boat trade. With the addition of a flywheel, prices jumped about three dollars on each engine.

The OK 49, which was simply a destroked sixty, featured a three-piece welded crankshaft. The engine was clearly identified by the numbers 49 stamped on the left lug on top. Outside of being a 1/4 inch shorter than the Special, and a 1/2 inch shorter than the Deluxe, it was difficult to quickly spot the difference between the 49 and 60 motors.

It was also about this time that the Herkimer Tool & Model Company launched its intensive campaign of "A Snap to Start", indicating the ease of starting its motors. The columnist owned three in his day and found them fairly tractable. However, with the spark lever slight-

ly advanced, the engines developed a mean streak and left their mark on many an unwary finger.

Although OK engines were generally accepted as pretty fair running engines, they never quite made the big time as did Brown, Super Cyclone, and Ohlsson (incidentally, in that order of succession). OK engines were a very much discussed engine, but one thing was certain, they enjoyed an excellent distributorship and could be found everywhere; even in the Western Auto Stores!

For the technically minded, the OK 49 featured a .900 bore (as did the 60 motors) with a stroke of .775. The OK timer consisted of a steel trunion pin cast into the bracket. It was claimed that by reaming the breaker arm bushing to close tolerances, point flutter was eliminated over full speed range.

Brebeck took out Patent No. 2,179,683 for crankcase and cylinder design, with the cylinder mounting flange forming a separator between the transfer and exhaust ports. With transfer ports located below the flange connection to the crankcase and the exhaust ports above, it was claimed this eliminated (or minimized) the expansion of the crankcase cylinder extension, thereby eliminating leaks between cylinder and crankcase. This allowed the cylinder to be machined from a solid billet of steel, with no gaskets. Pistons (ground and lapped) were machined from solid steel, hardened, ground, and finally lapped. The wrist pins were steel, hollow-drilled, with aluminum pads to prevent scoring. All engines were provided with translucent bakelite type tanks which were impervious to all solvents such as gasoline, ether, benzol, alcohol, etc.

OK 49 motors were rated at 1/5 horsepower turning at 6500 rpm. Weight, complete with coil, condenser, and tank was 11-1/4 ounces. Not bad for a complete assembly!

One point worth noting in the OK brochure on starting and running of its engines is the interesting piece of advice which could be applied to engines of today: "Use a good quality propeller weighing 1-1/4 to 1-3/4 ounces for breaking in the engine. After break-in, select a propeller of one to one-and-a-quarter ounce weight that is *carefully balanced*. The use of a propeller light in weight will cause the engine to be difficult to start due to lack of momentum to carry the piston past compression. A light propeller will also cause the engine to vibrate excessively."

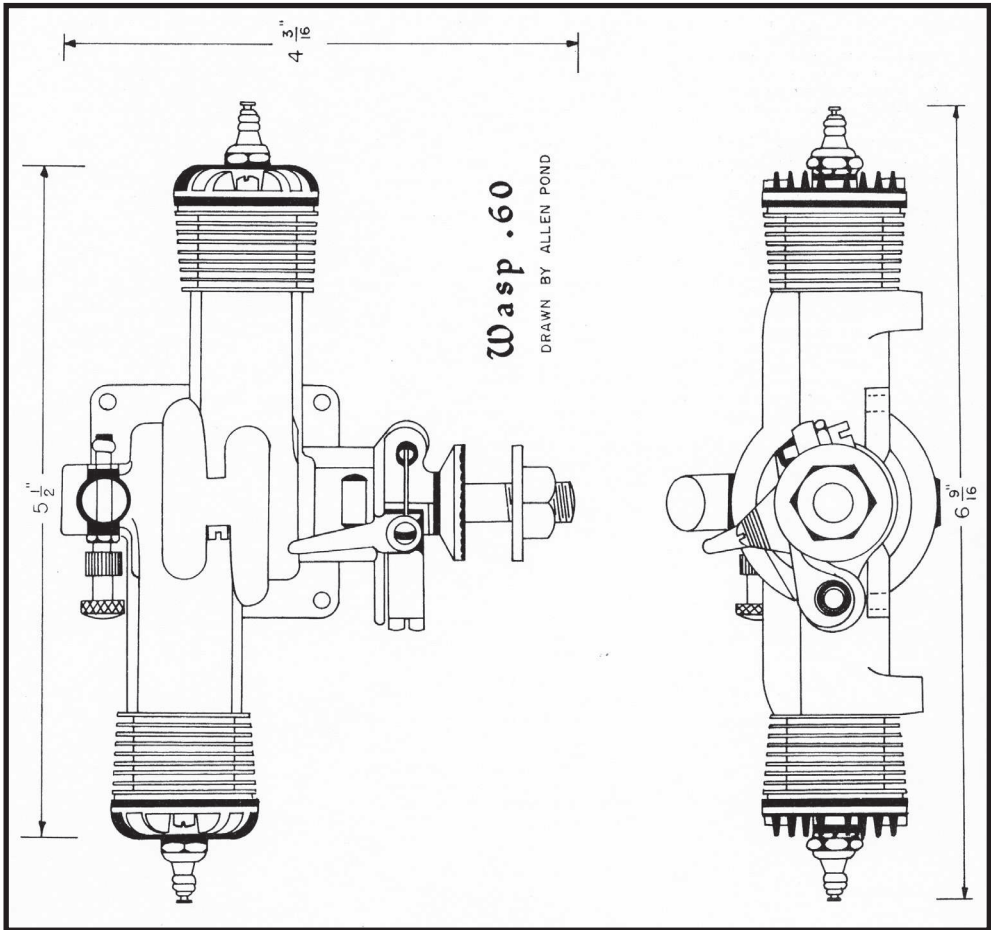

ENGINE OF THE MONTH

The first three or four years after the closing of World War II was a real bonanza period for engine manufacturers. All the money that had been pent up during those four war years burst like a dam, and anyone who had the remotest form of a model airplane engine could go into business.

Of the many "garage" type operations, Dewitt and John Ross started playing around with Vivell 35 parts and came up with a twin that ran creditably. From this humble start, the Wasp Twin evolved in 1944-45. The early advertisements were actually photos of the first prototype, featuring many hours of handwork.

The earliest advertisement appeared in the July 1946 issue of Air Trails, at the interesting price of \$35.00 (Ohlsson 60 Custom sold for \$21.50). Claims were made of rpm up to 10,000 although the best recorded speeds in any tests were about 7,800 rpm.

According to some of the more prominent collectors, the first dozen or so engines featured five screws in the cylinder head. The later production models were all six-screw type, with black crackle finish on the crankcase.

While on the subject of opening announcements, Model Airplane News did not feature any announcement of this new twin until a listing of engines appeared under the GMCO advertisement in July 1947. Almost a year later! Shortly thereafter, Air Trails gave the engine a complete technical write-up in their series of engine reviews.

Of course, the Wasp Twin engines underwent a series of improvements called the "Super-Wasp", Wasp Special, and the Scout Twin, the latter intended for mail-order business

only. Eventually, with the glow plug making big inroads on ignition type engines, the Micro Model Co. offered the Scout Twin (painted bright orange) without the ignition timer assemblies.

The Super Wasp can be regarded as the last gasp attempt of the company to put their product on a good selling basis. Some variations were brought out later (not for the model industry), hoping to catch the market for a self-contained generator unit. Alas, the Ohlsson 1.35 had already captured this phase, and it was only a matter of time before the Micro Model Co. ceased to exist. Interestingly enough, several fours were put together (very similar to the Ross Engine Co. history), but never progressed beyond the prototype stage.

As usual, the problem of uneven flow of fuel to each cylinder plagued the Wasp Twin design. In an attempt to create a motor where the cylinders were an equal distance from the fuel intake, the direct opposed Super Wasp was created. Naturally, one side always ran hotter than the other, as the fuel is taken into the crankcase in a counterclockwise direction from the action of the rotating crankshaft.

The connecting rods in this case were not aligned, but remained straight, with one behind the other. The designers of the motor evidently did not realize that a dynamic couple would be set up this way and would create a serious weakness.

This was evident when the firm attempted to produce a glow engine. The engines ran very unsatisfactorily, with connecting rods constantly "going out". Later on, bronze rods were substituted to help alleviate the problem, but only to a small degree. No question about it, the glow plug sounded the death knell of still another engine.

For the technically minded, the Wasp Twin weighed 10-1/2 ounces and came with two Champion sparks, but no other ignition accessories. A bore of .740 inches and stroke of .702 gave a piston displacement of .60 cubic inches. Height was 2-1/4 inches, length 4-3/16, and width was 6-9/16 (just right for a scale Piper

Crankcase (as noted before) was aluminum alloy, with each cylinder and one-half of the lower case as an individual unit (the two cylinders, when fitted together, were properly offset for connecting rod bearing clearance).

Pistons were stamped steel, hardened and ground to a high finish. An unusual feature of the two-piece I-beam connecting rod was the fact that it had a lower cap reminiscent of full-size automobile practice. The bearing caps could be removed (when the bearing started to pound out) and the cap filled to take up the slack. (Real shady mechanic work here!)

Timer casting was aluminum, with a standard auto type point such as found on OK .60, McCoy engines, etc. As noted by one reviewer, the timer arm was located in an easily accessible place to keep hamburger production down.

For those wishing to run a Wasp Twin, probably the best propellers were 14-6, 13-6, or 12-8 sizes, which gave 5700 to 6000 rpm using standard three-to-one fuels. As with most twins, the spark plugs had a tendency to foul, thereby impairing the starting qualities somewhat. Too bad that sales fell off so quickly as to prevent further refinement of this promising twin.

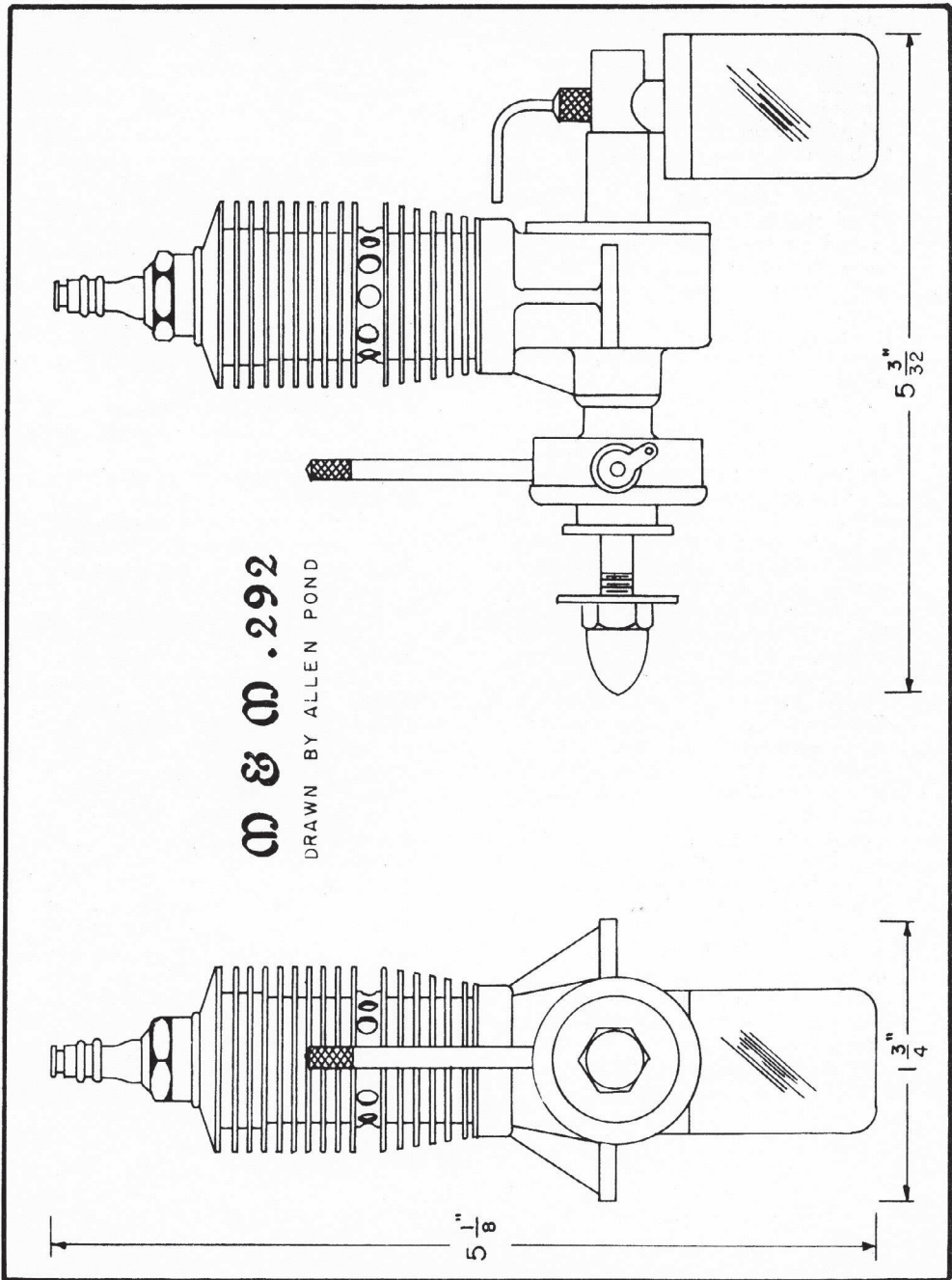

ENGINE OF THE MONTH

This month's engine is another small West Coast engine, manufactured primarily to take advantage of the tremendous interest in small models. In the early days of gas modeling, all the big designs were to be found on the East Coast. Out in California, a six-foot model was considered large; hence, the tremendous sales field for small engines. Numerous engines were produced on the West Coast, among those being; Trojan, Brat, Madewell, Husky, Ohlsson, and many others.

Strangely enough, after World War II, California manufacturers produced a tremendous number of ".60" size engines, such as Ohlsson, Super Cyclone, Atwood, Orwick, Hassad, Hornet, McCoy, Contestor, and many other smaller producers. Big designs were the vogue in California!

The M&M arrived on the screen shortly after the gas allowance type events were abandoned in favor of the limited engine run rule. In 1939, the first M&M engine made its appearance in its first advertisements in the August 1938 issue of Model Airplane News. The M&M Company, based on the tremendous acceptance of their wheels, had gotten into the market with a .23 size motor. Initial price was \$17.50, ready-to-fly.

With the new rules now extending Class B to include .29 size engines, M&M promptly brought out their newest effort, the .292 engine. Surprisingly, this was priced a dollar cheaper at \$16.50, as noted in the initial opening advertisement in the July 1939 issue of Model Airplane News. However, sales weren't that great, as the engine advertisements ceased in the January 1940 issue of MAN.

Basically the M&M 29 was a piston-valve type engine, which the manufacturers claimed was the first major improvement in model engines. Another claim was made that the piston and cylinder being symmetrical would allow the piston to rotate, making for uniform wear and maintaining good compression. In theory, this sounds great, but as the man said, "tain't so". The most successful two-cycle engines are those with the least amount of moving parts.

For those interested in the manufacturing specifications, the M&M engine featured cast iron cylinder and piston. The circumferential exhaust, later exploited in the Arden engines, was advertised as contributing to more power with quicker disposal of gases.

Points were fully enclosed to keep oil from fouling the points. For this reason, the motor operated equally well inverted or upright. Inverting the engine was quite simple, requiring only the intake tube and gas tank to be rotated 180 degrees. Probably took all of two or three seconds' work.

The engine also featured a transparent gas tank, which could be easily removed for cleaning. The so-called pull-tube carburetor needle valve (with micro-gas adjustment) featured no threads or pin holes to get clogged. The whole assembly could be easily taken apart for cleaning.

The motor displacement was .292, with bore of 23/32 and stroke of 32/32 (one inch to you). Base weight was 4-1/2 ounces. The engine was sold complete, ready-to-run, with spark coil. Recommended propeller size was 11-1/2 x 8 pitch. M&M claimed that it was not necessary to run the engine at high speed to develop full power (and naturally induce more wear).

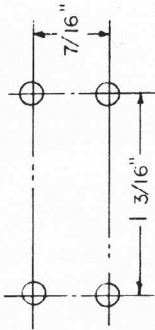

Marvin Junior 'A'

DRAWN BY ALLEN POND

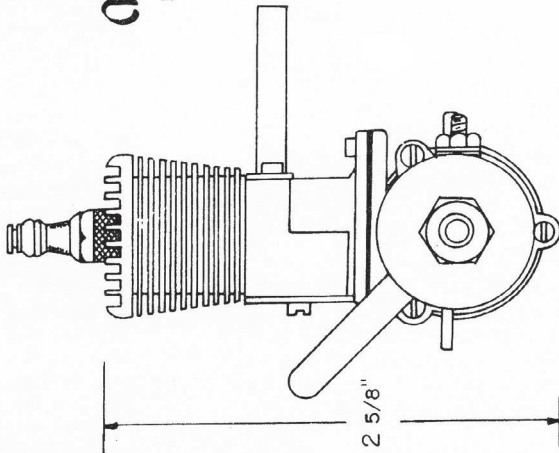
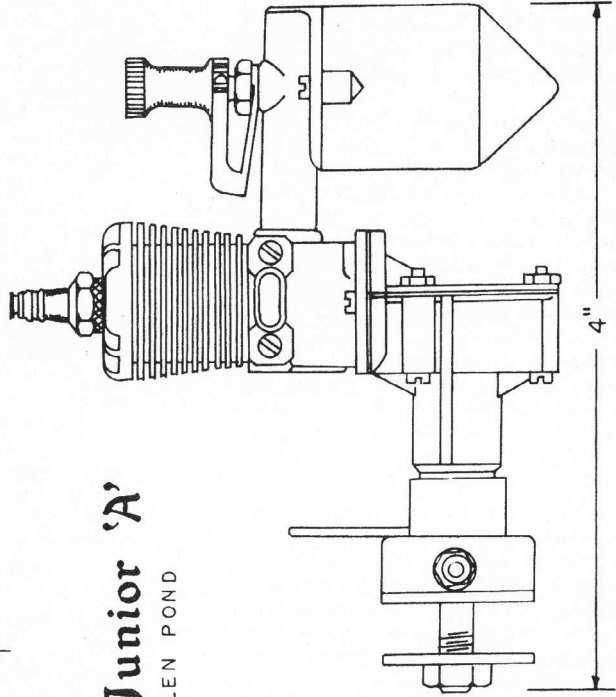

ENGINE OF THE MONTH

We interrupt the program at this point to bring you the monthly engine of the month (Remember the good old radio days?). We had to get the engine description somehow.

The Marvin Junior, Class A engine was actually an outgrowth of the original Dallaire Pee-Wee engine. In the late summer of 1937, the Pee Wee engine was developed by Frank Dallaire in his garage (where else in those days?). It didn't take long for Frank to get swamped with orders, necessitating a move from Frank's home in Detroit.

Sales continued to climb, and production started to fall behind. About this time, Frank was introduced to Ward Marvin through Ward's son, a modeler and customer of Dallaire.

With Marvin's background as an engineer with Chrysler Motors, the partnership was a natural, as Marvin had a home workshop. Starting with making parts only (on a spare time basis), it wasn't long before Marvin was making the entire engine.

Like every manufacturer, Marvin started incorporating changes in the motor to facilitate production. By 1939 Ward Marvin and his neighbor were producing an engine that bore little resemblance to the original Dallaire Pee Wee motor.

Frank Dallaire finally turned over all manufacturing rights to Marvin, feeling that the quality of the modified Pee Wee had fallen to such a poor state that he could no longer put his name on the engine. One of the biggest points that had been omitted was the practice Frank had of running each individual motor. Without this safeguard, some of the high zinc castings did leak in the crankcase, with consequent sluggish performance.

Advertising of the new motor appeared in 1940 Model Airplane News at the attractive price of \$7.95. How well this engine sold will never be known, as a fire in the plant destroyed all the records.

However, after World War II, Ward Marvin came out with the Marvin Jr. A, which differed from the pre-war model in that it had an Ohlsson-type needle valve, new style tank, and the head fins were milled as compared to the spoke fin type head similar to the GHQ. The original advertisements (as does the three-view) showed an enclosed timer, but as near as can be determined by engine collector enthusiasts, the open pre-war timer design was retained.

For the technically minded, the Marvin Jr. A engine featured a bore and stroke of 9/16 inches, giving a displacement of .139 cu. in. Bare weight was claimed to be eight ounces. This was rather rough, as the minimum weight allowed under the 1940 AMA rules was 11.12 ounces! Not much left for the model!

As pointed out before, the castings were 1/3 aluminum and 2/3 zinc, to allow for faster casting (also gave more porosity!). Cylinder and piston were cast iron with tool steel wrist pin and cast connecting rod. The crankshaft was fashioned from tool steel with oilite bronze main bearings.

Height of the engine was 3 inches, with an overall length of 4 inches. Some rather extravagant claims of 12,000 rpm performance were claimed, but never substantiated with propeller performances.

First announcements of the Junior Class A appeared in February 1946 Model Airplane News, followed by a picture of the motor in March at the initial price of \$13.40. By the June issue, the price had jumped to \$15.50, to take advantage of the extra money available after the war.

Advertisements continued until February of 1947, with only the engine being listed by Gotham Model Company thereafter. By June of that year, the sensational Arden 09 came out, which effectively sealed the doom of most small engine manufacturers such as Marvin. Any modeler worth his salt had to have an Arden or two in his stable of engines. So passed another interesting engine from the early 1940 era.

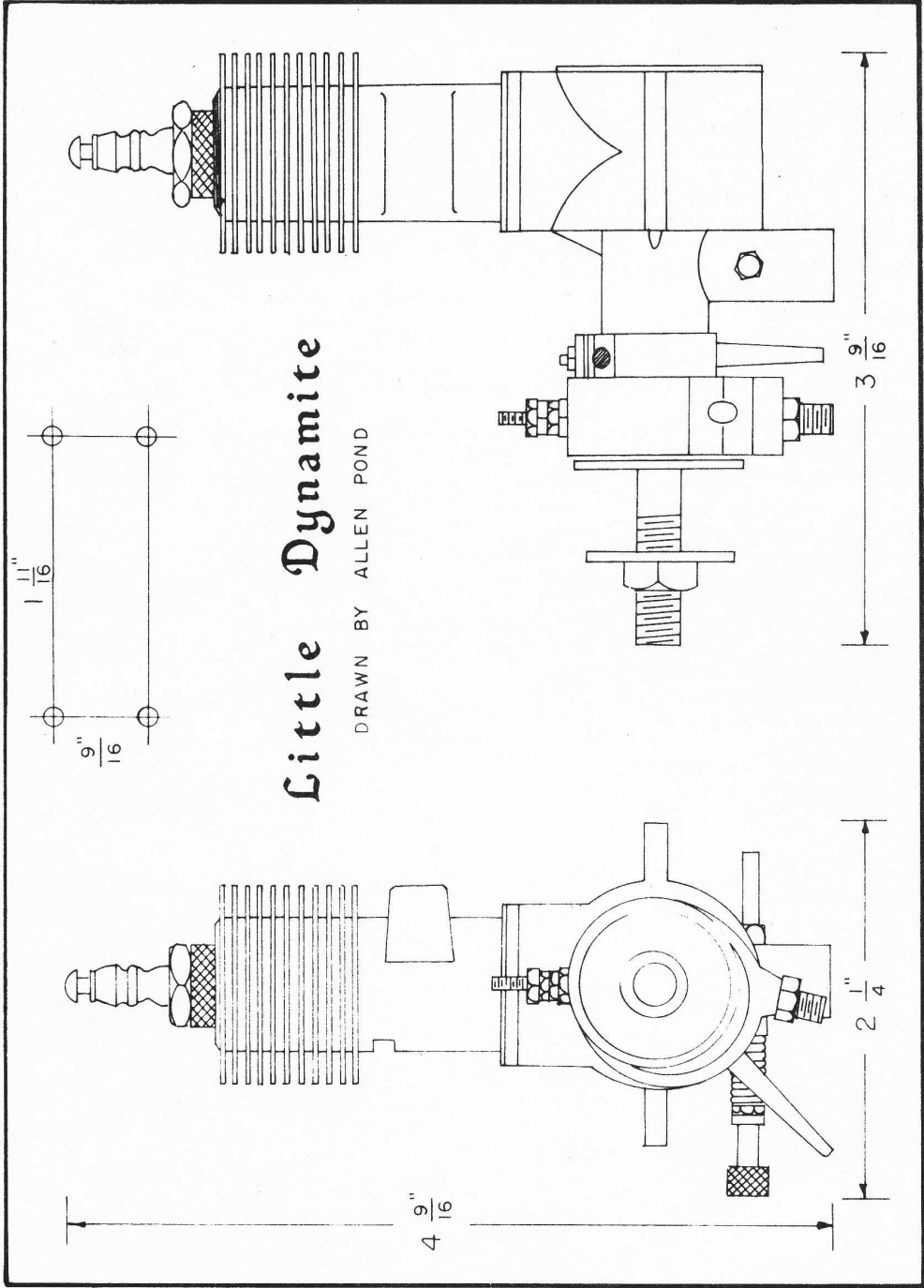

Little Dynamite

DRAWN BY ALLEN POND

ENGINE OF THE MONTH

In the autumn months of 1937, a group of Oakland (that town across the bay from San Francisco) modelers who had been flying 5- and 6-foot designs, such as Folly, Skeeter, etc., got together to discuss the possibility of improving the Baby Cyclone engine. This motor, although indisputably the economy king, left a little to be desired for power in the limited-engine-run events. These events were proving to be quite popular and appeared to set the trend for the future.

It was then that the Brown Motor Gas Engine Company was formed, located at 1933 Ashby Avenue, Berkeley, CA. Forming a "Technical Advisory Committee" were Dick Schumacher, Rod Doyle, Joe Culver, Mel Avery, and W.B. Curtiss. C. Curtis was in charge of sales.

Starting with the basic size of the Baby Cyclone (to which the Little Dynamite owes its ancestry despite all other claims) it wasn't long before Jim Brown, the machinist, and the boys, came up with an engine that ran much better. Best of all, the number of parts and gaskets had been reduced, and all parts greatly strengthened. It took quite a crash to damage this engine.

Jim Brown then started producing engines mostly on demand, as the engine was little known except locally. Dick Schumacher probably did more to popularize this engine than anyone else, as he won innumerable contests with his "Ethy" design powered by a Little Dynamite. It wasn't long before every prominent California model builder had a Little Dynamite in his stable.

In an early letter (March 6, 1938), Jim Brown wrote to Earl Vivell (a hobby dealer and distributor) on the various discounts available, ranging from 33 to 40 percent. At that time, the motor was priced at \$14.95,

Interestingly, when Offenbach took over the distributorship of the Little Dynamite, the price was raised to \$16.50. In all fairness, it must be pointed out that Smith coils and Champion Spark Plugs were included, making it a first class combination package.

For the technically minded, Little Dynamite motors were square; i.e., .781 inch bore and .781 inch stroke; giving a cubic inch displacement of .374 (same as the Baby Cyclone). Weight bare was 6-1/2 ounces, attesting to the ruggedness of the motor. The motor was rated at 1/5 horsepower at 6000 rpm, although the boys were able to get these engines to run much better than that.

The original timer on the Little Dynamite was a vertical exposed type, somewhat like the early Bunch engines. However, this was quickly replaced by the enclosed type which used automobile type points. These points made the engine very reliable in starting, as it would take a considerable amount of oil and grime to keep the points from operating effectively.

Overall height (including spark plug) was 4 inches, and length, from prop nut to crankcase cover, was 3-1/8 inches. Main bearings were large, being made from Johnson bronze. The needle valve was a carefully ground steel rod that was quite susceptible to dirt. Although the fine needle adjustment gave excellent performance, it also had its faults in that one could "needle" the engine a little too lean for flight.

With the advent of the war, production on all engines stopped in the Brown factory. After the war, a few engines were put out, but the parade had passed Jim by. Before he could develop a competitive engine, his untimely demise signaled the end to the line of Jim Brown engines.

complete with coil and condenser, and \$11.50 if you preferred it bare.

Shortly thereafter, Offenbach's Hobby Craft Supply (the largest Northern California distributor at that time) negotiated an exclusive distributorship with Jim Brown for the sale of Little Dynamite engines. In September, 1939, the initial announcement advertisement appeared in Model Airplane News. This proved to be only a "one-shot" deal. The glowing pictures painted by the distributor failed to materialize. Although many Little Dynamite motors were sold, the actual net profit was not much more than when he was selling direct to dealers. For this reason (one of the many), Jim eventually dropped production of the Little Dynamite in favor of his downdraft carburetor version known as the "Thermite".

Little Dynamite motors, when they first hit the market, were sensational. Here was an engine the same size as the Baby Cyclone, but what a difference in performance! Class C models featuring Little Dynamite motors quickly dominated the West Coast competitions. Only one model, Foote's Westerner, was the exception to the case, using Super Cyclone, Ohlsson, and other size 60 motors.

Little Dynamites were a bit mean to start, particularly if you flooded one. Once one got the hang of operating the engine, they were extremely reliable. Probably the biggest bugaboo facing the modeler was the careful removal of a broken propeller. If you pulled the cam off with the prop, you had to be extremely careful to note its exact position. There were eight different locations for the cam! Once you lost track of the position, one could spend a considerable amount of time finding the correct cam orientation.

Torpedo Special

DRAWN BY ALLEN POND

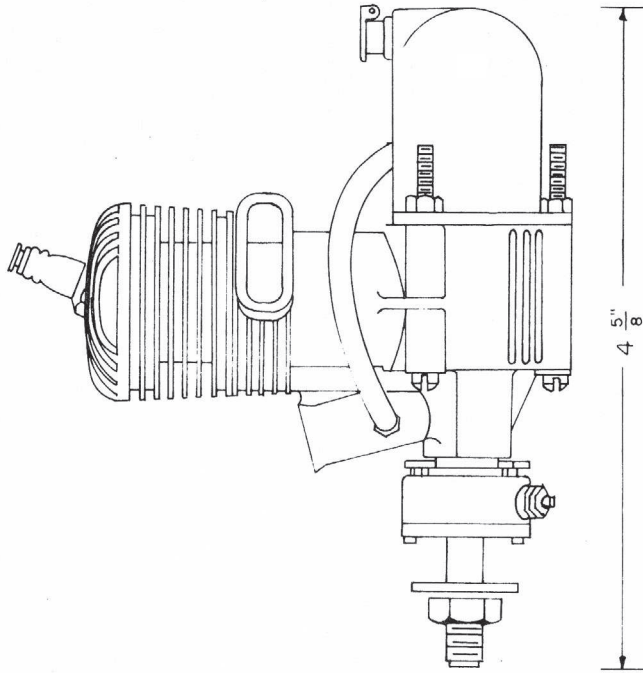
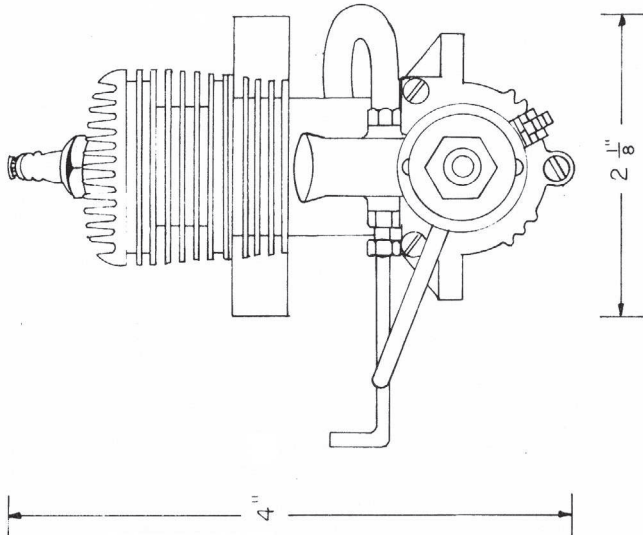
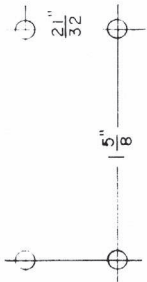

MOTOR OF THE MONTH

As mentioned previously, this column features a monthly old-time engine review primarily to show what the old engines looked like, and in addition, to supply motor mounting information to help plan your next old-timer project.

The September 1946 issue of Model Airplane News featured a full page in the front section announcing that Torpedo was back. This was the Torpedo twin stack as manufactured by Miniature Motors, Inc., of 8400 Higuera St., Culver City, California.

(However, if you went back a few issues, this ad began to look more than a little suspicious. Several months earlier, Miniature Motors had placed ads for the Bullet motor, one of several designs by Bill Atwood, which he had sold to Miniature, inventory, name, and all.

Meanwhile, back at the ranch, Lud Kading and Johnny Brodbeck [K&B, get it?] had teamed up and started production of their own engine. Discovering that Atwood still had the name and inventory on the Torpedo, they purchased it all, and assigned the name to their new engine. Their first order amounted to half of the first production run, for Bob Morgan's Model Supply Co., 3473 Tweedy Blvd., South Gate, California, a large West Coast distributor. Morgan ran an ad in the July 1946 issue of M.A.N., with the following headline "BACK AGAIN, and hotter than Ever, The Record Breaking TORPEDO '29'."

Getting back to the Miniature Motors ad which appeared two months later, close examination verifies the fact that the illustration was indeed a clever artist's air-brushed modification of a photo of the K&B Torpedo!

Obviously, Kading and Brodbeck slapped a lawsuit on Miniature Motors over its illegal use of the Torpedo name. Miniature, in the meanwhile, went into production on the twin-stacker that apparently didn't even exist at the time their ad appeared. The suit dragged on for about a year, and just when K&B was about to collect a sizeable payoff. . . Johnny Brodbeck laughingly says he had already figured out how to spend it. . . Miniature Motors declared bankruptcy, and that was that! wcn)

For the above reasons, Torpedo Specials are a little rare and harder to find than the standard K&B Torpedo. Actually, in retrospect, the glow plug made the K&B Torpedo the tremendous success it was, as it fit perfectly with the new glow fuel and plug. This helped hasten the demise of the Torpedo Special.

The Torpedo Special when first placed on the market, sold for \$18.50 less coil and condenser, though deliveries didn't start until late in the year. The rival K&B Torpedo sold for exactly the same price. However, the specifications of the two engines differed slightly as the Torpedo Special (commonly called the twin-stack) featured a .300 cu. in. displacement, with a .711 bore and stroke of .750, giving all-up weight of 7 oz.

Compare this with the K&B Torpedo, claiming a .299 cu. in. displacement, with a .725 bore and stroke of .724 inches. Their weight was set at 7-1/2 ounces. Not too much to choose from!

For the technically minded, the Torpedo Special featured a steel honed cylinder, one-piece heat-treated steel crankshaft, mehanite piston (ground to 5RMS finish, or so claimed), with bronze bearings for the crankshaft and connecting rods. The con rod was aluminum alloy, with a bronze wrist pin. The cases were die-cast aluminum alloys.

Here was an excellent example of competition forcing one company to give up its motor manufacturing because of the efforts of the dynamic duo, Kading and Brodbeck. The twosome was smart enough to cater directly to the modeler and his wants. An excellent example of this was the K&B booth at the Nationals every year, starting in 1946. They would repair or replace every motor broken at the Nationals. This was a terrific deal for the contestant whose model had just crashed, and found the only thing keeping him from flying was the lack of a complete engine.

Of course, the wise guys always took advantage of this deal, as many modelers used to take their motors, ruined over the regular season, and pawn them off on John Brodbeck as broken at the Nationals. Despite this, the offer still goes on. Starting in 1973, the booth was moved into the well-known orange and purple van, which visits all of the event sites.

Forster 29

DRAWN BY ALLEN POND

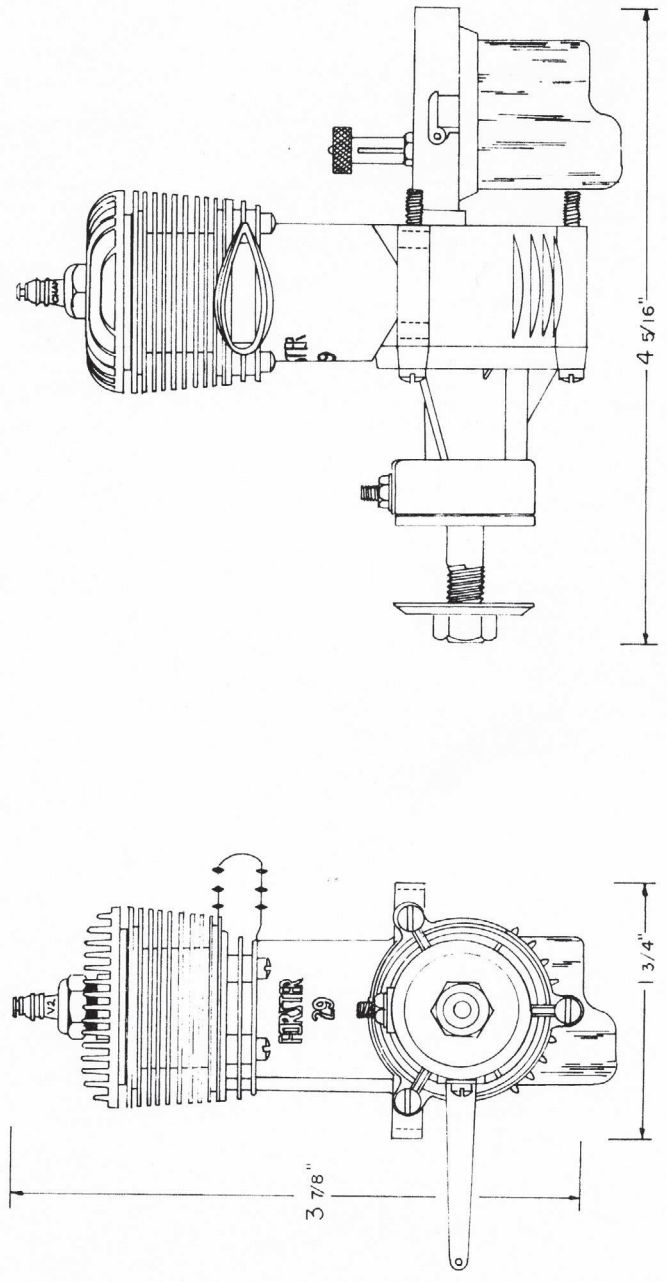
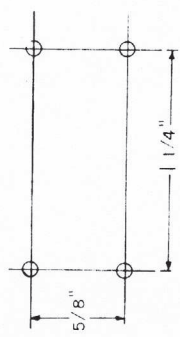

ENGINE OF THE MONTH

No question about it, the advent of the Zipper gave Class B the impetus needed for development of new engines for this event.

With everyone coming out with 27 to 29 size engines, it didn't take the Forster people very long to realize that here was the bonanza they were looking for. The Forster 99 sales had fallen off badly, as the demand for smaller engines was overwhelming.

In the May 1940 issue of Model Airplane News, an announcement appeared in the Forster Bros. advertisement, with news of a "blessed event". In short, a new .29 cu. in. size engine had been developed by the Forster concern.

This was followed very quickly in the June issue, wherein it was stated that the new engine was now ready for delivery at the price of \$15.50. If you were still doubtful, the engine was to be debuted at the Chicago Gas Show, May 7 to 11.

Finally, in the July MAN issue, a half-page advertisement appeared, with the Forster 29 illustrated for the first time.

Claims of dependable power based on the new rotary valve (actually a rear rotary) were made of 1/5 horsepower; the same rating as a Brown Jr.! What most people didn't know at the time was that all rpm and power curves derived on the Forster 29 were based on the use of alcohol and castor oil, instead of the standard three-to-one gas and oil mix.

In a review of this engine in the July 1947 issue of Air Trails, using standard fuel, the Forster 29 turned 6800 rpm on a 12/5 Flo-Torque propeller, 7,200 rpm on a 10/8 Mercury prop, and 10,600 rpm on an 8/10 X-Cell propeller. It didn't take the boys long to start using alcohol in the Forster 29 engine!

According to their advertising brochure, the new Forster 29 was a quality engine based on the concern's long experience with the

Forster 99. Claims for the superior performance of 1/5 horsepower were attributed to the new "supercharging" rotary valves, special "oilite" high speed bearings, and a new type domed, high-turbulence, high-compression chamber said to result in faster power impulses. In addition to this, a feature called "clutch" propeller lock was advertised as making it the safest motor on the market for not throwing propellers not properly tightened.

The Forster 29 was a good engine and was well made. For the technically minded, the new 29 featured a bore and stroke of .750 x .6718 inches, giving a displacement of .297 cubic inches. Weight was 5-3/4 ounces. The mounting feature was the same as Ohlsson, giving the modeler the choice of beam or radial type mounting. An aluminum crankcase featured cooling fins, as the Forster people felt this provided better cooling and appearance. An alloy steel crankshaft, hardened and ground to size, was provided, with a tubular crank pin. The alloy steel high dome piston was lapped to a cylinder machined from solid bar alloy steel stock. The wrist pin, of tubular steel, was fitted with "snap" lock retainers. To round things out, the connecting rod was an aluminum alloy I-beam, bushed with oilite bearings.

Like all engines that are not updated to compete with others, in this case the hot K&B Torpedo, the Forster gradually lost sales and eventually, production was discontinued.

For those fellows who are interested in obtaining a post-war model (actually the glow version fitted with timer points) of the Forster 29R or 35R, these are now being manufactured by M-G, based on the old dies purchased from Forster Brothers. Price for either engine is \$49.00, less coil and condenser. These can be obtained from M-G Engines, P.O. Box 6026, Denver, CO 80206.

Brat

DRAWN BY ALLEN POND

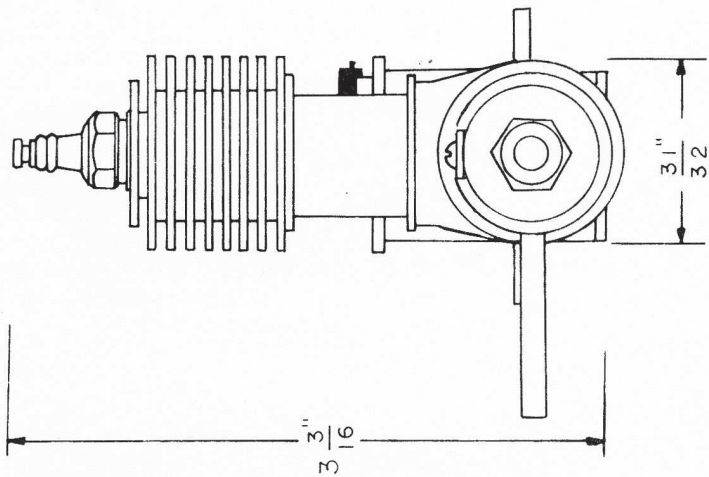
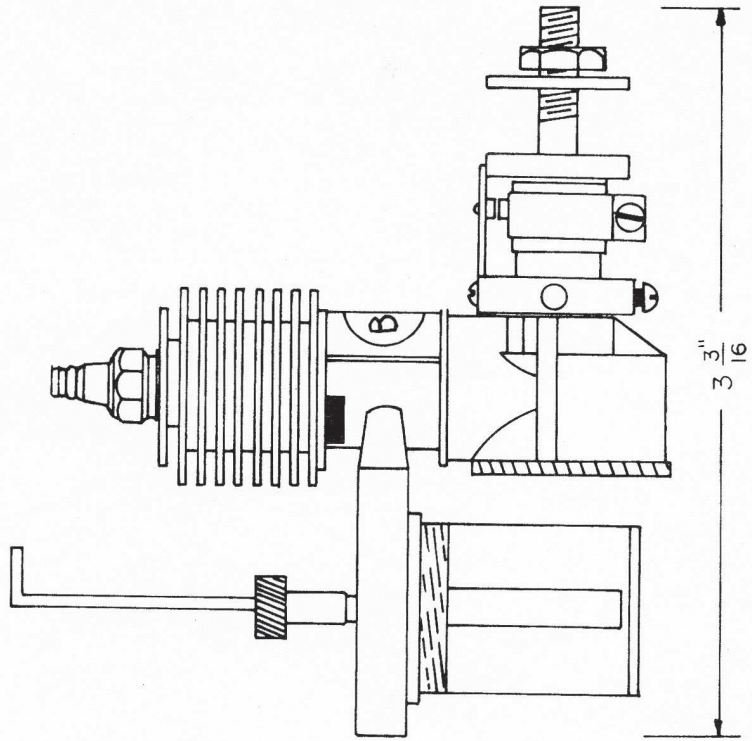
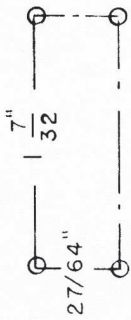

MOTOR OF THE MONTH

It was 1937 in the Los Angeles area, a real hotbed of model aviation at that time, and the precision model was king. With the large soarer unnecessary (in direct comparison to the huge floaters being produced on the East Coast), the popularity of small models increased.

Small models had obvious advantages: low cost of construction, quicker to build, easy to transport, and best of all, they didn't break as easily! It was then that Jack Keener, living in Los Angeles at that time, produced a fairly reliable engine of approximately .14 cu. in. displacement.

Although the claim of easy starting was made, this was only in comparison to the other small engines on the market, which were miserable to start. Brats ran pretty fair, and according to Karl Carlson, who produced about 100 Hex head-type Brat engines (which he called "repro" engines), Brats started fairly easy. Nowadays, with better batteries, better wiring techniques, and better coils, it is no great surprise.

Jack Keener made about 5,000 Brat engines in all, first beginning production at his shop at 2429 W. Washington in Los Angeles. Continuing production of Brat engines, Keener moved to Oakland, where he resides today.

The 1938 version, which is illustrated featured a bore of $17/32$ of an inch and stroke of $5/8$ of an inch. With an overall height of $3-1/4$ inches, the motor weighed in at $3-1/3$ ounces. Although claims of 3500 to 7500 rpm were made, most Brats turned in the 5 to 6000 rpm area.

The Keener Aircraft Industries sold the Brat engine for \$16.50 complete. This included transparent fuel tank, coil, condenser, plug, propeller, and a can of S.A.E. 70 wt. oil! How about that last item for the unhappy modeler who had no motorcycle shop in his town, and 70 wt. oil was hard to find!

Bullet

DRAWN BY ALLEN POND

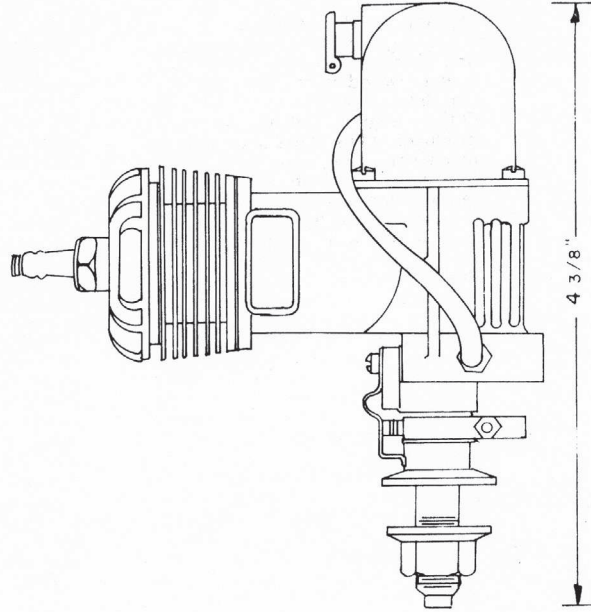
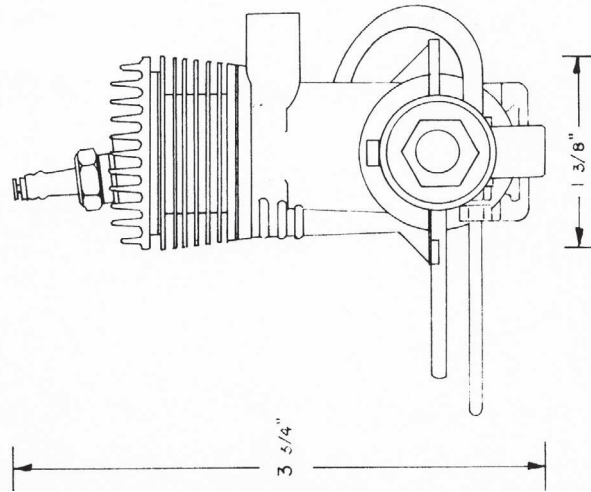
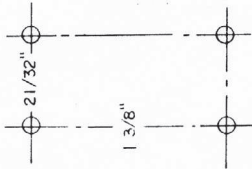

MOTOR OF THE MONTH

The engine featured this month is one of the many designs produced by Bill Atwood during the 1938-1941 era. Bill can be likened to the "Joe Ott" of engines. Ott was a prolific producer of kits. It has been known that, when selling a line of 25¢ kits to a department chain, if they preferred a line of 15% kits, Ott would produce them in less than two days!

So it was with Atwood and his motors at that time. Starting with the Bullet, Phantom, and Torpedo, it was indeed hard to tell which part belonged to which, and why. All his engines had their individual idiosyncrasies, but all ran quite well. And the prices! Were they ever attractive! Most engines ranged from 10 to 13 dollars, which was considerably less than most competitive engines.

The particular model Bullet we are showing was the so-called 1946 version. By this time, the manufacturing rights had been taken over by Miniature Motors, of Culver City, California. In 1946, there was plenty of money that had been dammed up by wartime restrictions. Now, anyone who had an engine that would perform halfway decently, could make sales and prosper. Hence, the reason for so many of Bill Atwood's designs on the market at that time.

The original engine (1939 version) was called the Phantom Bullet,

actually being manufactured by the Phantom Motor Co. When the motor was again produced in 1946, the revised version was known as the Bullet 100. Sold for the attractive price of \$12.75, the motor came without coil or condenser.

For the technically minded, the Bullet was a .275 cubic inch displacement motor, with 3/4-inch bore and 5/8-inch stroke. Weight was 4-3/4 ounces. The motor castings were all die-cast of Dow metal (magnesium alloy), with mehanite piston and honed steel cylinder.

All Dow metal crankcases of the early days were extremely susceptible to crashes. Although die-casting did lend itself to extremely fast production, the crankcase lugs broke quite easily (same problem with Baby Cyclone cases). For this reason, these series of Atwood engines are difficult to find in original (undamaged) condition. Later models employed die-cast aluminum crankcases to improve strength.

Early Air Trails issues note, in a review of the engine, that strobotac tests show the following figures:

7,500 rpm with 9 x 9-1/2 Hi-Rev
Prop

8,500 rpm with 10 x 4 Flo-Torque
Prop

All tests were based on use of standard three-to-one gas and oil mixtures. No tests were run using methanol-based fuels.

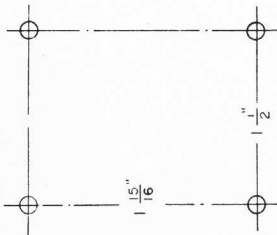

EDCO Skydevil

DRAWN BY ALLEN POND

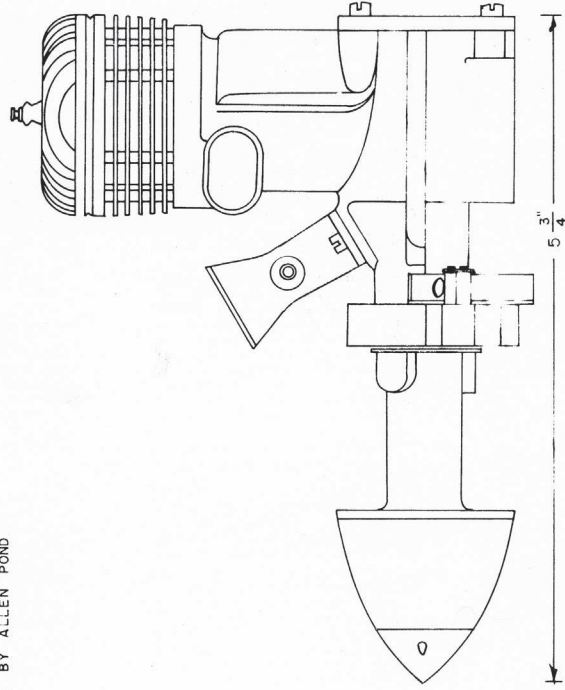
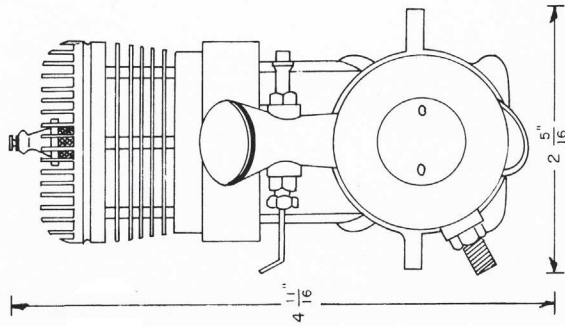
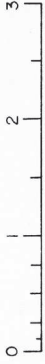

ENGINE OF THE MONTH

Not many modern day modelers are aware of the Edco Sky Devil, as produced by the Engineering Development Company (Frank Howarth, Pres.) and designed by Ira Hassad.

This engine, a mass produced version of the Hassad Custom, came out directly after World War II. Interestingly enough, the name, Sky Devil, had been employed before, as quite a few Hassad Customs were sold under this name. The name, incidentally, was derived from the airplane club associated with Tom Herbert's Westchester Hobbies in White Plains, which first sold the engine. With the "Sky Devils" promoting the engine in contests, it was a natural to name the motor.

To back up a little, Ira Hassad, who is still actively running a machine shop in San Diego, was one of the early pioneers of model engines. He and Irwin Ohlsson attended Polytechnic High in Los Angeles, where they singly and collectively attempted to build miniature gas engines. After graduation in 1934, Hassad first worked for McFarland motors, along with Irwin Ohlsson.

When the company folded, their paths separated and Hassad caught on with Grand Central Air Terminal at Glendale, the center for Curtiss-Wright. About this time, Major C.C. Moseley decided to produce a model gas engine based on Bill Atwood's design, and Hassad and Mel Anderson were hired along with Atwood. But, that is another story we will run in the future.

Edco advertisements (primarily in Model Craftsman for the auto racing trade) showed two versions of the Sky

Devil, a 1500 SD for airplanes and a 1500 SDR for race cars. The airplane version featured a .bore of .940 inches and a stroke of .935. However, the race car version, to comply with the .61 cu. in. engine limitation, had a stroke of .935 inches, with a reduced bore of .910.

When interviewed by Bill Thompson, an ardent engine collector residing in San Diego, Ira readily admitted that the Sky Devil production version never did meet the performance standards of the Custom. According to Bill, the thing that was missing in mass production was the care that Ira Hassad took when assembling each engine. However, many owners were aware of Hassad's rework service, and for \$15.00 could have Ira turn their engine into a first-rate winner.

With the year of 1947 starting and the demand for engines finally satisfied, it didn't take long for sales to start falling off, especially in view of the demise of big time model race car competition. With the advent of the glow plug and the introduction of the powerful small motors, the company quickly fell into financial trouble and discontinued production. All in all, about 1,000 to 1,500 Edco Sky Devil engines were produced.

The columnist would be remiss in not acknowledging the tremendous amount of research work done by Bill Thompson, who published a very complete history of all Hassad engines in the Model Engine Collectors Journal back in 1973. Many thanks are due to Bill for most of the foregoing information.

Orwick 23

DRAWN BY ALLEN POND



$1 \frac{7}{16}$ " B.C.
3 4-40 NC
BOLTS
120°

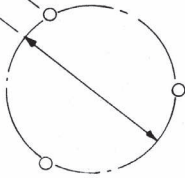

MTG. LAYOUT

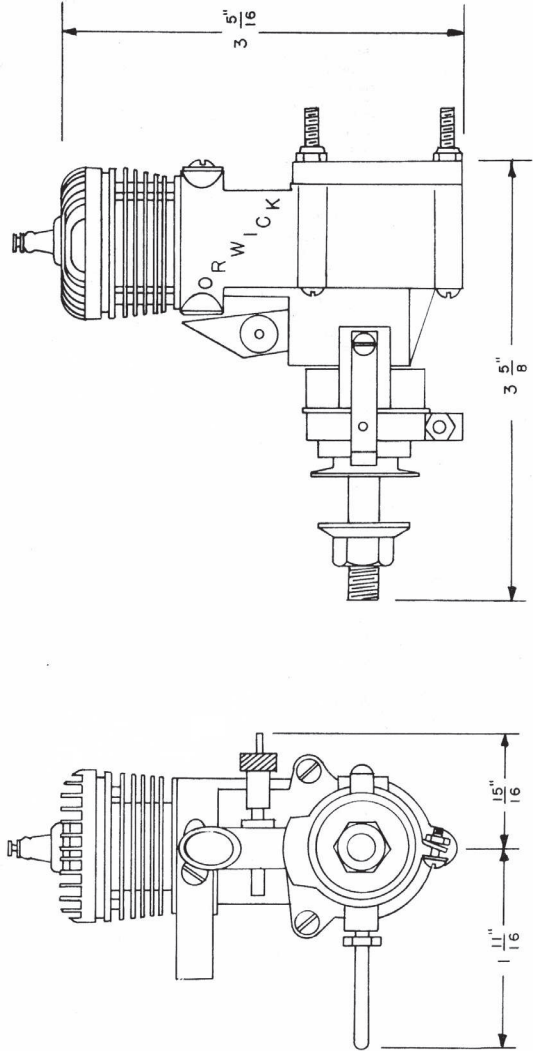

ENGINE OF THE MONTH

Most modelers are quite familiar with Hank Orwick's .64 cu. in. engine that was so highly successful, but few know that H.C. Orwick put out other sizes of engines, notably .23, .29, and .32. There was also a .73 cu. in. engine known as the "Miracle 60" (it was a miracle if it ever was a 60). This engine, incidentally, led to the AMA restriction of a maximum .65 cu. in. motor displacement.

In describing the Orwick .23 this month, we are indebted to Karl Carlson, who obtained a considerable amount of correspondence between Orwick and Hoffman Model Supply, of Sioux City, Iowa. In those days, Orwick had just broken up with Cunningham and was operating out of 1523 West 70th St., Los Angeles, CA. The breakup of the partnership was inevitable, with Orwick, the perfectionist, always delaying production, and Cunningham, the impatient one, wanting to get into immediate production regardless of minor faults of the particular engine.

In one of his letters to Hoffman, Orwick gives out the following on his Orwick .23: "We have a pleasant surprise for you . . . an Orwick .23 has been mailed to you yesterday. We haven't received our literature yet, so I will attempt to give you a few instructions on it. The engine requires very little choking, due to the size of the crankshaft in comparison with the engine. Once or twice, with the propeller being pulled through, is usually plenty. The needle valve is not a bit sensitive, so it can be screwed in or out by the round (turn) if necessary without taking the engine from one extreme to the other. The top of the tank should be at least level with the needle valve. A little bit above won't hurt.

"The engine you receive will require a small amount of breaking in, but after about 15 minutes, it should run wide open if you leave the needle valve set in a rich two-cycle. We have had more success in flying with a 9-inch propeller by letting it wind up. The 10-inch prop appears to hold the rpm down. The Comet 9-inch prop has proven good for us and should be available in your part of the country. The engine should turn in excess of 10,000 rpm for most efficiency."

In another letter, Hank again hands out some advice which many modelers today would do well to heed:

"You (Hoffman) mentioned that this customer couldn't get the engine to run more than half advanced. We check-ran it here and the motor gets up and really arcs, but it is a little tight to run more than 10,000 rpm. Over that speed, it shows a slight tendency to stick, but please inform your customer there is nothing to be gained in taking one engine apart to see why it is tight. Disassembly is bad medicine for any engine, and should be avoided entirely except in the most extreme emergencies."

In his letter of March 6, 1947, Hank Orwick reveals some rather interesting philosophy regarding the use of bushings versus ball bearings. We pick up his letter at this point:

"You mentioned that you had prospective customers who would not buy the Orwick engine because it had no ball bearings. My personal opinion is that this is not the reason they won't buy it. Addition of ball bearings would increase the weight by 5 or 6 ounces. Then they would complain about the engine being too heavy. Besides, it isn't simply a matter of adding ball bearings. It would require an entirely new engine design. In the first place, we couldn't use the front rotary anymore. You say OK (Herkimer) does it, but they use only one bearing instead of two. The shaft isn't supported on both ends, and they knock out their mains all the time. After you have covered all of this with those hard-to-sell customers, ask them why it is that General Electric, on their high-speed motors that turn 125,000 rpm, uses bushings instead of ball bearings. We don't want you to misunderstand us, but this is our opinion and all our experience with the engine in *free flight* has born us out in this contention. If your customers really insist on ball bearings, why not sell them a McCoy?"

In the light of the foregoing, it is no great surprise that the basic engine was continued by Hi Johnson when he took over the Orwick concern after Hank's unfortunate demise. As they say, the proof is in the pudding, and Johnson proved it for another ten years with the same basic design. No question about it, Orwick was an excellent craftsman who knew his engines, and they were the most powerful of their time.

Bluestreak

DRAWN BY ALLEN POND

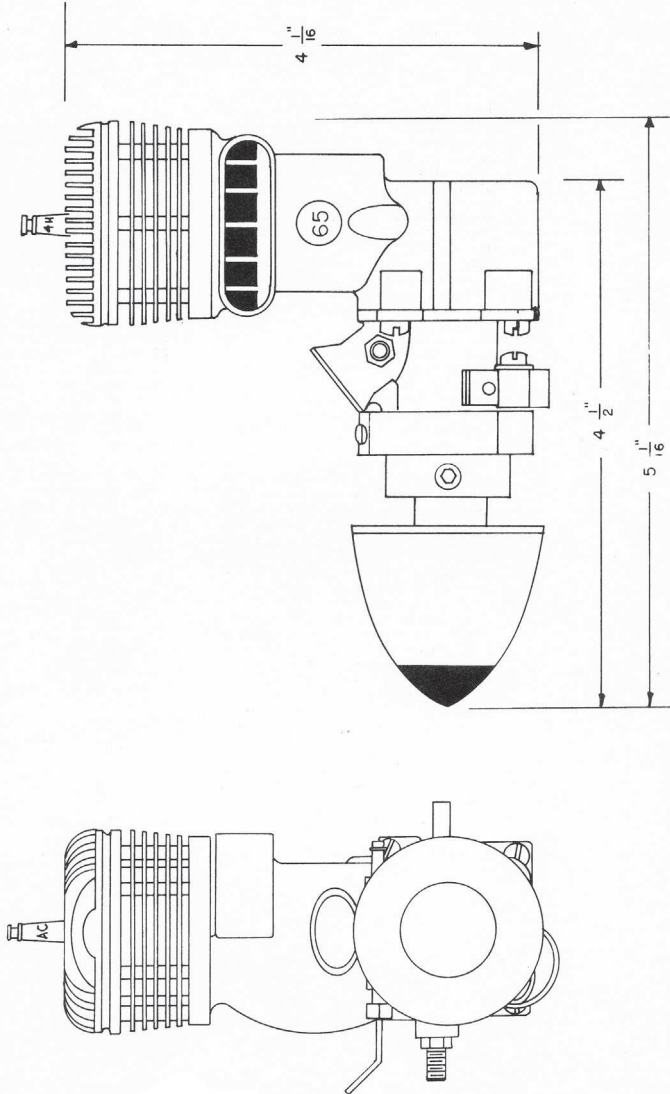
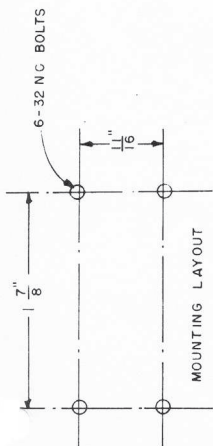

ENGINE OF THE MONTH

This month's engine is a follow-on to the Hassad Sky Devil we wrote up several months ago.

Actually, the Hassad Bluestreak came about when the Engineering Development Co. (EDCO) got into financial trouble and had to declare bankruptcy. Among the main creditors were the Tyce Brothers of Chula Vista (a town south of San Diego), known as the International Tool Company (Aircraft Engineering Service), who found themselves the owners of a large supply of Sky Devil parts.

In an attempt to salvage some of their investment, the company hired Ira Hassad to come up with an engine that would use the parts on hand. Race cars had run their course and it now being 1947, there was a tremendous demand for a large, hot controlline and free flight aircraft motor.

By early 1948, Hassad had come up with a new design. To show his versatility, he made up the dies for the permanent mold castings. This included crankcase, cover, and extension. The rest of the motor was made up from the Edco parts. A slight difference in machining for the pistons and heads was evolved to allow for a left-hand exhaust.

As far as can be verified, about 1500 to 2000 engines were produced. Surprisingly, there were a few left to be sold by Ted Tyce as late as 1972. By April of 1973, the firm announced that all parts to make any engines had been sold.

It was no great surprise that the engine turned out to be a good one, inasmuch as it used all internal parts of the Model 1500 SD Sky Devil. Specifications, of course, remained the same as the Sky Devil, with the exception of the exhaust and bypass ports being rotated 90 degrees.

Although the new engine promptly won the championship stunt event at Santa Anita in 1948, the Hassad engine was unable to hold its own against all the other new racing engines coming on the market. A remarkable similarity to the problems of the Sky Devil arose, as the Bluestreak still did not perform as well as the original Hassad Custom. No question about it, that extra finishing touch Ira gave to his reworked engines made a definite difference.

Interviewed by Bill Thompson, of San Diego (to whom we are indebted for this information), Hassad stated that the Bluestreak was his last engine. I always felt bad that the engine did not become popular. It just didn't have what was needed to pull controlline speed planes. Until this day, I can't tell you why.

By this time, Ira Hassad finally had enough money and equipment to start his own machine shop to specialize in work on full-size hot rods and racers. This may come as a surprise to many, but Ira had always wanted to work with full-sized machines. Actually, working with models had ceased to be fun, and here was the chance to launch a new business into the automobile racing business. A quote from Ira might be in order: "I don't know if I was getting tired of models, or the others were getting better."

To this day, Ira and his wife run a large machine shop in El Cajon (a town east of San Diego). The business is known as Lomar Machine Works (Lomar from his wife's name, Lois Marie). As noted by Bill Thompson, Ira said the secret of his success was "Dare to be different".

Hetherington Meteor 23

DRAWN BY ALLEN POND

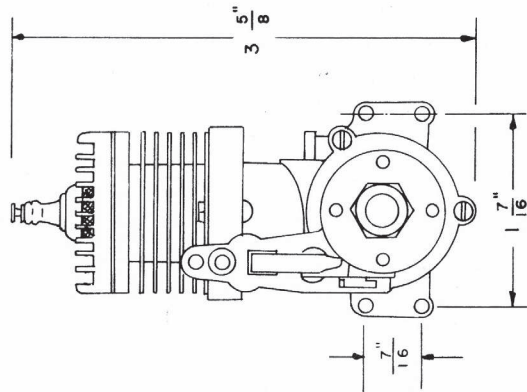
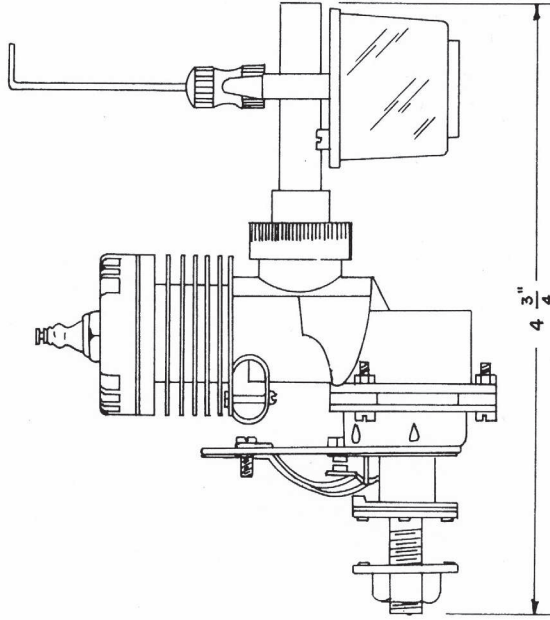

ENGINE OF THE MONTH

For this month's motor, the Hetherington Meteor, we are indebted to Karl Carlson for all the literature and information. Karl Carlson and Dick Dwyer purchased all of the dies and stock from Bob Hetherington and hope to put out about 100 copies of this engine. However, that is another story we will relate and get into in more detail.

Bob Hetherington is one of the real old time engine manufacturers, beginning in the late twenties. Compressed air motors were the big thing then, and Hetherington produced all types of air motors. Bob was actually pretty successful in marketing this engine, as it was not until 1932 that he actually became interested in gasoline motors and produced his first.

If you think the forgoing was strange, R.J. Hetherington was a pharmacist by trade! His father was a machinist with an old shop that eventually Bob fell heir to.

This shop has had little improvements for over 40 years. According to Karl Carlson, when he first walked into the place, it resembled a museum with an overhead shafting and pulley set-up for all the old machines. Among those were a 1918 lathe, a 1908 punch press, and other old drill presses. Actually, the machinery was in good shape and capable of turning out good work.

In the early days when Hetherington was developing his production engine (he made over 30 prototypes!), he did commercial work, such as manufacturing scrapers, a mixing device for adding the coloring to oleomargarine (in the thirties, a California law initiated by the butter industry forbade the coloring of oleomargarine, so it looked like lard and was therefore unappealing), and best of all, small gold dredges for those wishing to speed up gold mining.

The Meteor engine, which has been selected as this month's motor, was first produced in the late thirties. His first engines were sold in 1933 for airplanes, boats, and race cars. Although not extensively advertised, Meteor engines were good engines and had a fairly good reputation. Seventeen years later, Bob was producing a glow version of his

ignition, Meteor 23. At that time (1950), the engines were available in both styles, ignition or glow.

These engines could be run inverted, sideways, or upright, as the locking nut would allow easy movement of the tank to suit engine position. Matter of fact, the engine could be run at any angle with this neat locking device.

The engine came with a beam mount. The only mounting plate is shown in the front view. For an additional sum, beam type mounts could be purchased. Probably the surprising thing about this motor was the two-to-one mixture of gasoline and SAE 70 wt. oil. According to their figures the power output, weight, and speed of the ignition motor was essentially the same as the glow motor!

Meteor engines were usual in construction, being fabricated of pressed steel, brazed together. The crankcase required thirteen different pieces to be spot-welded together. Even the piston was die-stamped, requiring twelve machining operations to finish it. The ideas, although novel, were not entirely original, as the Crosley motor was made of sheet metal. Why did Hetherington make his engines this way? Bob said it was the challenge of making the most difficult engine.

For those hoping to find Hetherington in his shop, forget it. Bob had a stroke in 1978 which impaired his health. He retired shortly after that and closed the shop.

For the technically minded, the Meteor 23 featured a bore of .6875 inches and a stroke of .625 inches. Fuel intake is accomplished by the use of an automatic (or flutter) valve at the rear of the engine. The valve discharges directly into the bypass between the crankcase and the upper cylinder. This is the main reason for being able to run the motor in any position. Rated horsepower was 1/6 at 8000 rpm, using an 8x9 propeller. Weight was 6 oz. The engine could be made to run clockwise by simply adjusting the location of the timer, a neat feature if one wanted to build a twin-engine model.

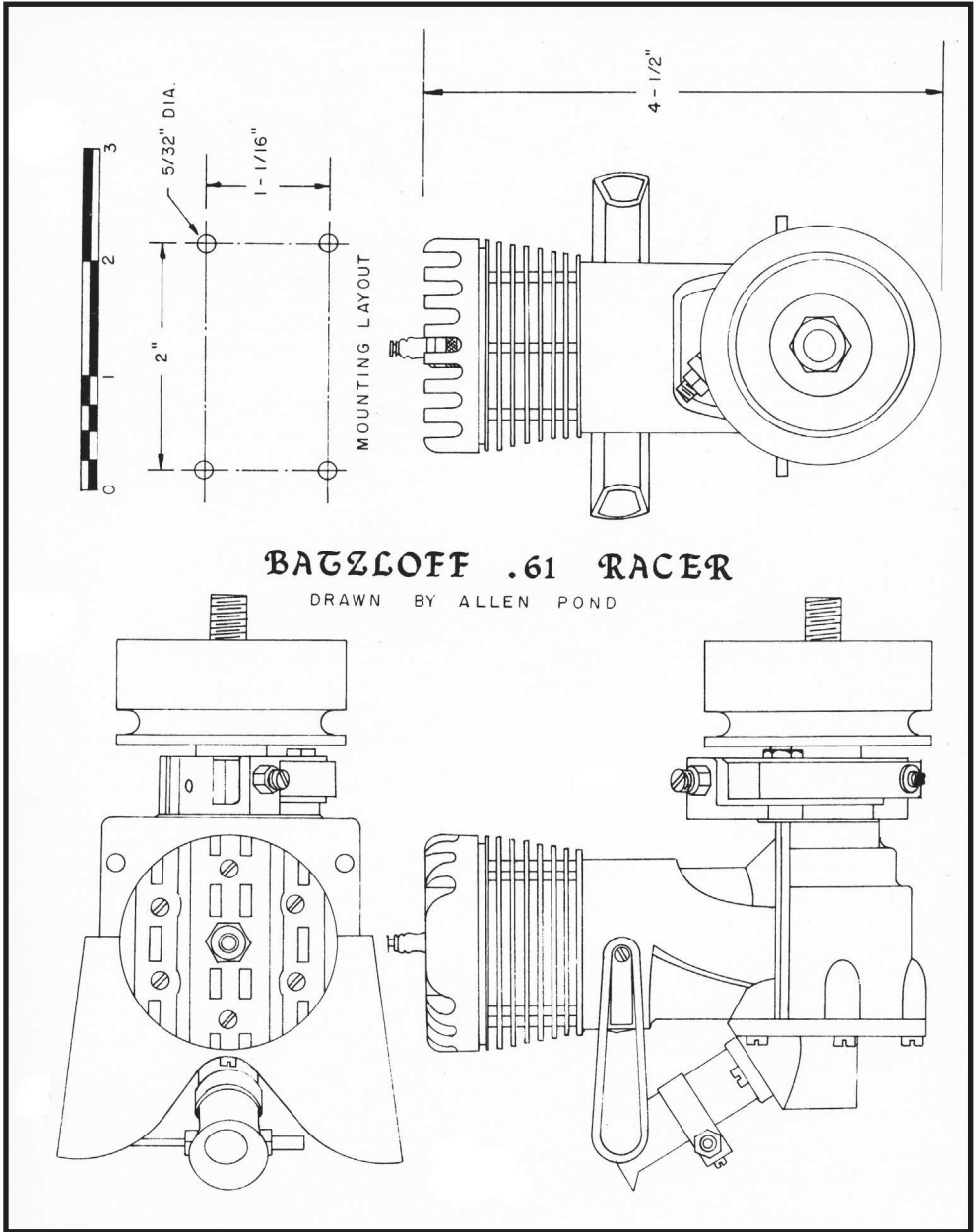

ENGINE OF THE MONTH

This month's engine is a rare one indeed, the Batzloff racing engine, which highly resembles the Hassad, a very successful race car motor. Small wonder, as Bill Batzloff and Ira Hassad were fairly close buddies and ran race cars using Hassad engines before World War II.

Batzloff and Hassad first attracted national attention at the National Miniature Race Car Championships at Chicago on July 4, 1941. Hassad preferred to race on the rails, as his motor really turned on when coming out of the turns. This was due to the terrific amount of torque developed by the Hassad, as compared to the free-running Dooling and Hornet motors. The latter engines were virtually unbeatable on the cable lines, where drag was a low factor.

Although many felt Hassad had the best engine on the field, in one of his qualifying runs the high tension lead vibrated loose with two laps to go.

Surprisingly, the first four places went to the Los Angeles boys, with Kenny Clark leading the way with a Super Cyclone powered Rexner Zipper car. Disappointed Ira Hassad was second with his Richter car, using his unbeatable Hassad engine; his time of 70.80 mph barely losing to Clark's 71.03 mph. Interestingly enough, Bill Batzloff placed sixth with 67.16 mph.

Another unknown fact was that Wally Francisco (later of Francisco Fuels, Powermist, etc.) was blending fuel for the two boys using cologne as a blending ingredient! No problem in knowing who was making a run with that fuel! Actually, the Easterners were so taken with the performance of Hassad and Batzloff that all 12 engines Hassad had taken with him were promptly sold.

As can be seen from the drawings, the Batzloff engine was heavily influenced by Hassad. We are indebted to Russ Barrera, who had original Batzloff castings, and Karl Carlson, who did the machining and assembly work to produce the actual engine to work from. As Carlson pointed out, the similarity of a Batzloff engine to a Hassad is quite pronounced when the intake is placed directly behind the timer points. Voila! A Hassad engine!

Of course, World War II knocked off all engine developments at this time, but as soon as the Japanese waved the white flag, and materials were again available, all engine manufacturers were hard at it.

From best estimates and records, it appears there were only several dozen of these engines were actually completed and sold. The engine had the intake and exhausts similar to the Hassad, except for being reversed. The large butterfly exhaust stacks, so much a Hassad trademark, were freely used.

Bill Batzloff, by trade, was a deep-sea diver employed by Scripps Oceanographic Institute in La Jolla, California. Bil was also a machinist of sorts, which accounted for his interest in racing engines. Ironically, Batzloff died in the doctor's office while waiting for an examination. Bill passed away in August, 1966, at the age of 54.

For the technically minded, the displacement was .61 cu. in. with a bore of 29/32 of an inch and stroke of 15/16 of an inch (not quite "square"). Flywheel figures showed a range of 12,000 to 13,000 rpm (similar to Hassad). Inasmuch as the engine was just another racing engine with no real improvements over existing designs, the engine dropped quickly from the racing scene.

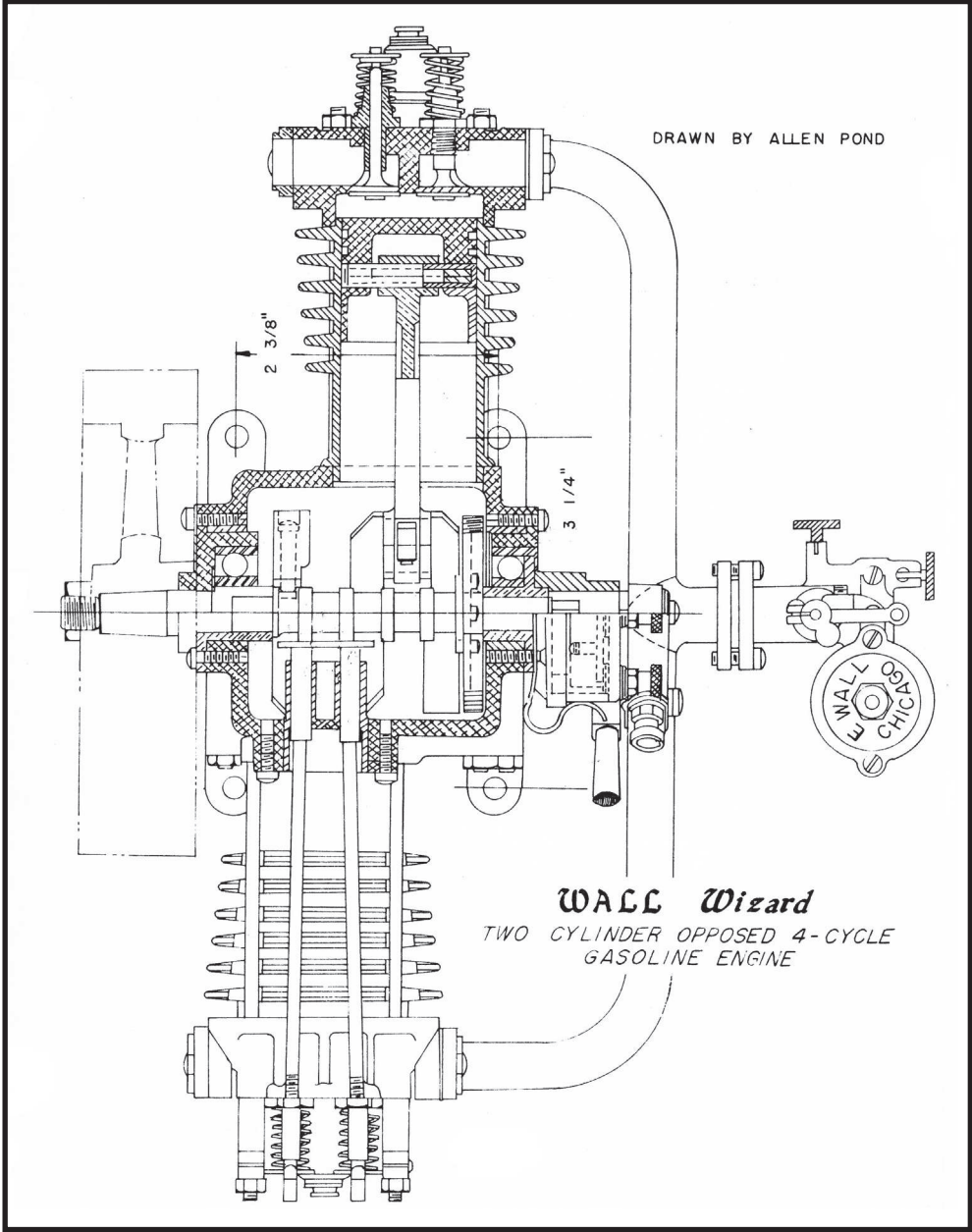

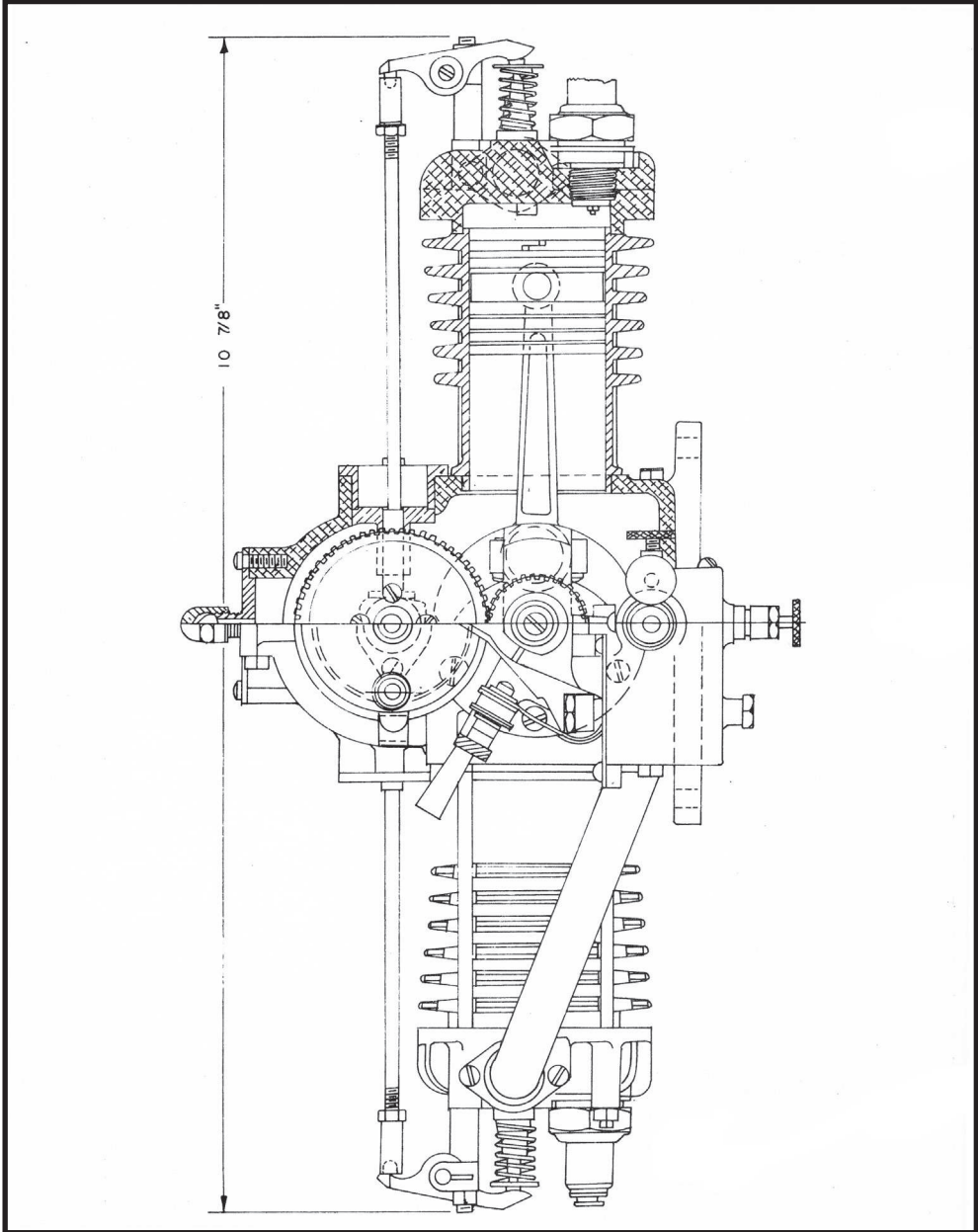

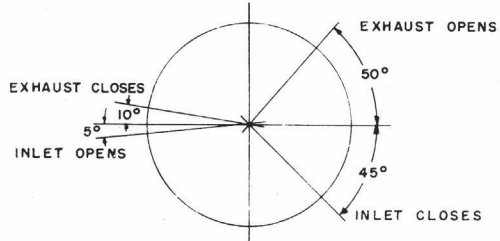

INLET OPENS 5° B.T.C.
 CLOSURES 45° A.B.C.
 EXHAUST OPENS 50° B.B.C.
 CLOSURES 10° A.T.C.

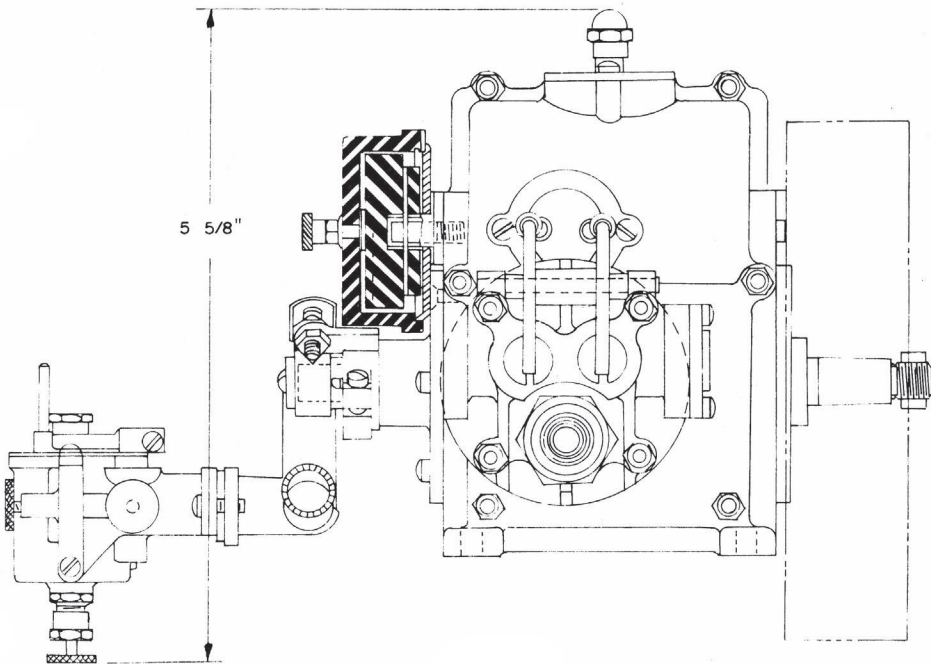

ENGINE OF THE MONTH

For this month's engine, we have reached way back in the early Thirties to bring you what the early gas model pioneers were using prior to the advent of the sensational lightweight Brown Jr.

Elmer A Wall, located in those days at 5900 North Fairfield Avenue, Chicago, had a shop devoted particularly to the development and production of gasoline engines. As noted by R.E. Dowd, the Experimental Model Editor of *Aero Digest*, Wall had about every type gas engine you would want at that time: air-cooled and water-cooled; two ignition types, both horizontal and vertical inline; and two cycles and four cycles. The laboratory (if you could call the shop that) was simply loaded with all sorts of ideas and engines.

Wall ran most of his engines with mufflers, otherwise the noise indoors would be ear-splitting. Demonstrations in his shop were commonplace, as Wall had been developing gas engines for over 40 years. Most all of his engines reflected his long experience in building his own engines, carburetors, and ignition systems.

Wall offered a service to the modeler in those days who was interested in building his own engine from castings.

Many a classroom used a Wall Wizard or Wall Jr. (single cylinder version) as a machine shop project. The best part in building one of these engines was the implied guarantee of success based on a proven engine design.

Wall engines were big and heavy, generally necessitating an eight to ten-foot model weighing over ten pounds, ready to fly. Although most of his engines only weighed about two pounds, by the time you added propeller (always hand-carved in those days), gas tank, ignition coil, and batteries, you could figure on another 1-1/2 pounds. With an initial weight of 3-1/2 to 4 pounds, it took a stout heart indeed to venture on a gas model project.

Wall engines featured aluminum crankcases with bronze bushings for the

crankshaft bearing. The crankshaft of about 7/16-inch diameter (!!) was cast steel furnished with cast-on extensions to facilitate machining by providing the eccentric centers. Brass counterbalance weights were attached by four 5-40 machine screws. The crankshaft terminated in a No. 1 Morse taper. The journals also featured oil retention grooves near the ends.

Rather than use steel connecting rods with bushings in each end, Wall used bronze conrods. Although the connecting rod was provided as an integral casting, after machining, it had to be split to put it on the crankshaft. Two 5-40 screws then held the bearing cap on (as in standard automotive practice). Lubrication holes in each end were provided for oil access.

The Wall engines featured cast-iron cylinders, generally with six cooling fins. However, the transfer port cover and the cylinder head were aluminum, the head being equipped with radial fins for cooling. The head was tapped for a 12-millimeter Bosch spark plug.

Wall designed his own carburetors, generally of the horizontal multi-jet type. These carburetors featured cork float, needle valve, and adjusting screws for idling and air bleed (and we thought we had something new in model engines when this feature was added to R/C stunt engines about 10-15 years ago!!).

Both the intake and exhaust manifolds were made of aluminum.

Wall employed a standard Delco-Remy breaker arm for his make-and-break ignition system that was actuated by a cam on the shaft. A small automotive type spark coil was provided in the engine kit. The timer was located in the rear of the crankcase (like the later OK .60 engines) where fingers can be kept in one piece.

Interestingly enough, Elmer Wall used a fuel mixture of 15 parts gasoline to one part oil. Every indication is that Wall engines were fairly economical, as they only turned in the 2000 rpm plus area.

CONDOR

KOPPER "6 0" KING

DRAWN BY ALLEN POND

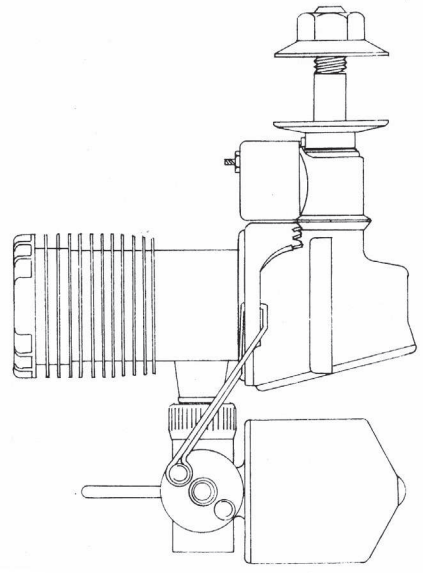
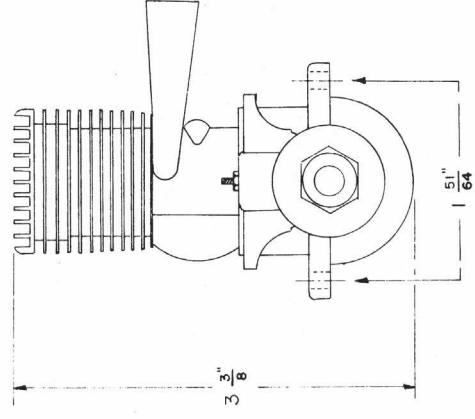
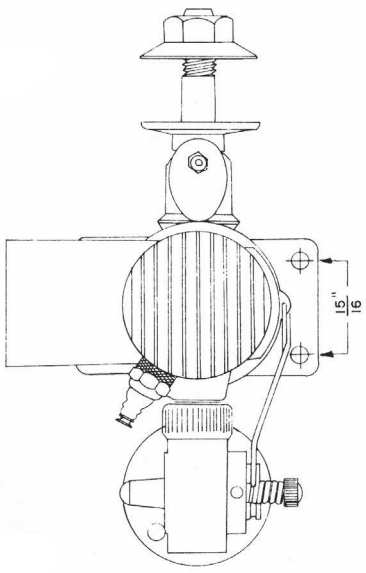
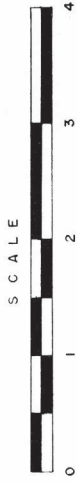

ENGINE OF THE MONTH

This month's motor, the Kopper King 60, known also as the Condor 60, was a very compact .60 size engine. The most unusual feature of this engine was the combined control of gas, spark, and air with only one lever. One could choke the motor by closing the throttle arm and then opening the air intake, at the same time advancing the spark timing. Certainly did cut down on the amount of items to adjust to produce the best running condition.

According to Charlie Folk, who also wrote an article for the Engine Collectors Journal, the engine was actually designed by an English toolmaker, Roy Lloyd, in the late thirties. To start with, like most engines of that era, production was strictly a garage operation, being produced in Bob Gardner's basement in Pittsburgh, Pennsylvania. Of course, Lloyd and Gardner produced other engines such as the Condor Midget, but we are primarily concerned with the Kopper King 60.

As mentioned, the first engines were produced in the basement shop using only a South Bend lathe, a drill press, and several other pieces of small equipment. Surprisingly, Lloyd and Gardner employed two apprentice machinists. Each engine was hand-lapped and carefully fitted (they didn't have a honing machine) utilizing a special lapping compound. Each engine was bench run, disassembled, cleaned, then reassembled and boxed for shipment.

About this time, the Pittsburgh Brass Manufacturing Co. became interested in obtaining the manufacturing rights for this engine. The deal as completed gave 50% to Pittsburgh Brass for all rights and privileges to the patent rights. Before WW-II started, and during the time Lloyd and Gardner were associated with Pittsburgh Brass, most of their time was spent in perfecting the design for production purposes. Actually, only about 100 engines were produced before a lack of materials brought on by WW-II shut production down.

Around 1943, Gardner and Lloyd formed the Rob Roy Co. (ROBERT Gardner and ROY Lloyd) to get in on the defense production work. So, when Pittsburgh Brass was approached in 1945 by Robert Edward Miller, of Miller

Machine Products, Chicago, Illinois, to purchase all rights to the Condor 60 engine, he had to pay \$2,000 to Pittsburgh and a like amount to the Rob Roy Co. to obtain full rights.

Miller then assembled engines in his plant and set up production of those parts needed (pistons, etc.). Condor Kopper King 60 engines were sold through a large hobby shop known as Aerocrafters in 1946. The actual amount of production is unknown, as the serialization of the engines does not appear to be uniform.

As noted before, the Kopper King was one of the smallest .60 engines produced; however, it did turn 13x6 and 14x6 propellers quite creditably. The unusually good finish on the piston and cylinder wall was in no small part responsible for this performance. For those who get slightly confused on the pre-WW-II and post-war models, there was little difference except the shaft size was reduced from 9/32 to 1/4 inch (to take advantage of standardized parts), and the connecting rod was changed from bronze to steel.

For the technically minded, the Condor Kopper King 60 featured a bore of .960 and stroke of .937, giving a displacement of .60 cu. in. The weight was advertised at 7-3/4 ounces (pretty light for a .60). A standard Champion V-2 plug was mounted horizontally at about ten o'clock looking down from the top with the prop shaft on the right.

The Condor .60 featured a neat way of inverting the motor. All that was necessary was to loosen the split nut on the carburetor, detach the spring wire connecting link, reverse position of the carburetor, tighten the split nut, and reattach the spring wire on the lower brass boss of the carburetor throttle body and to the opposite side of the timer segment ring. This method was quite reminiscent of the system used by the Hetherington Meteor. Recommended fuel mixture was four parts of high test or ethyl gasoline (not regular or low-lead!) to one part of S.A.E. 70 oil.

In conclusion, the Condor .60 was just another good engine that failed to survive, simply because the market was already flooded with good and proven .60 size motors having good capital backing.

Hetherington .49 Meteor

DRAWN BY ALLEN POND

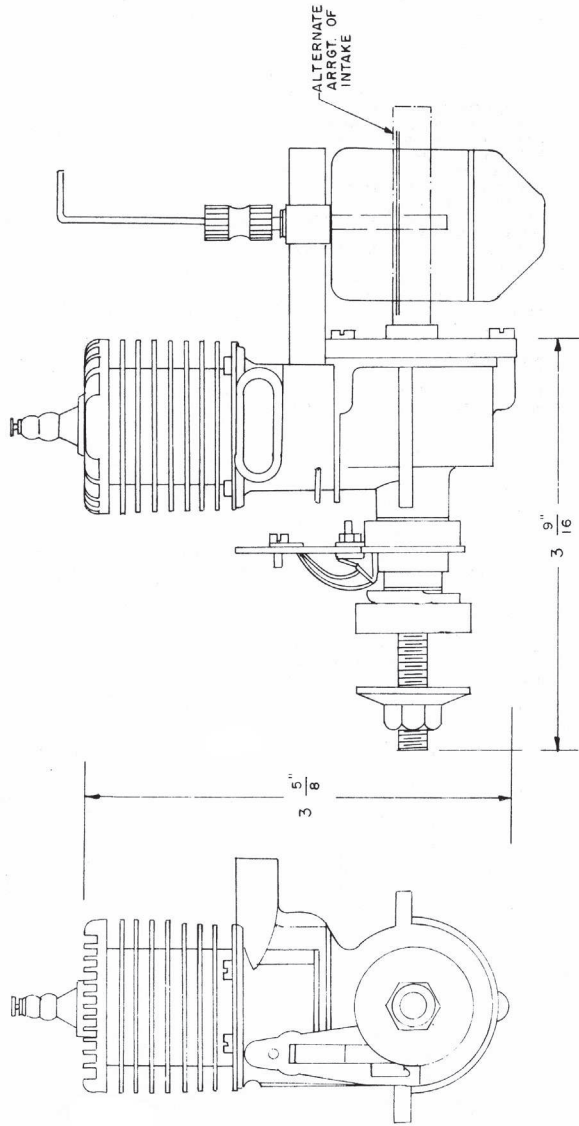
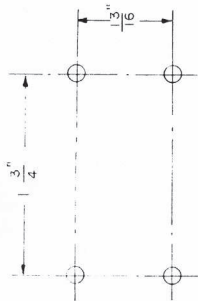

MOTOR OF THE MONTH

This month's motor is more or less a follow-on to the article we did on the Hetherington Meteor. Of the many size engines made by Bob Hetherington, the next most common to the Meteor .23 was the .49 cu. in. size, drawings of which are featured. The columnist is indebted to Karl Carlson and particularly Dick Dwyer for obtaining information from Bob. He states the following sand-cast engines were produced:

	Manufactured	Sold
Meteor .15	1	None
Meteor .19	6	3 or 4
Meteor .23	175-200	All
Meteor .49	30	All

The last two motors were of copper-brazed steel manufacture. Bob states the above figures may not be entirely accurate, but are the best he can recall from memory. In addition, he made and sold 120 compressed air engines, primarily through Desmond's Store in downtown Los Angeles and Terrence Vincent, who ran a concession in the Fifth Street Store. No mail orders were ever filled to the best of his recollection.

As Bob pointed out in the previous article, Hetherington got started in the engine business by first building compressed air motors of aluminum. (Most C.A. engines were built of brass. Bert Pond, of Hoosier Hot Shot C.A. fame, used brass fishing ferrules for pistons and liners.) When Bob's motors came out, the Depression was in full swing, and although all motors were sold, the demand wasn't that great to warrant continued production.

Hetherington got started in gasoline two-cycle engines early in 1932. The motor looked somewhat like a Brown Jr., but was anything but a howling success. The bore was .875 inches with a 1-inch stroke. Far from discouraged, the next engine was a .49 with a .875-inch bore and .812-inch stroke. The cylinder was made of cast iron, with an aluminum sleeve with fins to cool the cylinder. The head was screwed into the bore. The finned sleeve worked but was not en-

tirely practical. Cylinder heads that screwed onto the outside of the cylinder sleeve were also tried.

Another brainstorm tried was the attempt to remove the piston baffle (Bob was 30 years ahead of his time, with Super Tigre and Fox using flat-head pistons). This was done by drilling holes at an angle through a thickened section of the cylinder wall. (A novel bypass idea!) The idea worked, but the engine would not two cycle unless the needle valve was very carefully adjusted.

The biggest problem was that as fuel in the tank dropped, the fuel mixture would lean out, and in many cases, the engine would stop even if adjusted rich at first. Bob feels the cause was not enough capacity in the bypass holes.

All sorts of ideas were tried. Some engines were made with the cylinder screwed into the crankcase, and some cylinders were flanged and bolted in the crankcase. Still other cylinders were attached to full crankcases which included the exhaust port and exhaust (as per drawing). After making several .49 size engines like this, about a half dozen .19s and one .15 engine followed. To the best of his knowledge, Bob says the .15 was never run.

About 1940, Bob got the idea of making an engine of steel, held together by copper brazing, as a result of a magazine article describing a European automobile engine made that way. Work on the Meteor .23 commenced in 1940 and continued for ten years. At the end of that time, business fell off sharply and any work done thereafter was experimental.

For those collectors wondering where the serial numbers went, Hetherington states he never bothered to number his engines in any way. So, if you have a Hetherington engine, hang on to it; there weren't that many made!!

To back up a little, when Hetherington made his first engine, he had no experience on which to draw. There simply wasn't any information available on engines small enough to be used to

power airplanes and boats. A few engines had been made by individuals, and some of these engines were described and pictured in library books. Information was generally so sketchy that to make an engine, the most basic principles and methods had to be learned the hard way, through experience.

After the first engine, the .875-inch bore was employed and used on all engines until the introduction of the .23. Various designs were tried. All early engines had sand-cast aluminum crankcases. Cast-iron cylinders were used, as were steel cylinders. More than half of the engines were made in the large size (.49).

As previously noted, all sorts of experiments were made; cast-iron pistons without rings, aluminum pistons with rings, and various ideas for timers. Spark plugs were not available and had to be made using glass tubing with a very small hole through it. Later on, this problem was solved when one of spark plug manufacturers made up a batch of very small plugs to be given away at the Chicago fair. These plugs, incidentally, would be considered large by today's standards.

As can be seen on the drawing, various porting ideas were tried. The first idea was to have the intake port just below the exhaust port. Some intakes were placed in the rear of the engine, while others had the intake placed on one side with the exhaust on the opposite side. Still other designs were made in which the intake was through a thin plate, or flutter valve, located at the rear of the crankcase cover.

The name "Meteor" was adopted in 1935 and a few more engines were sold locally. Occasionally, a few orders from distant states were received as a result of some small advertising. All the large engines had a stroke of .812 inches to give a displacement of .495 cubic inches. Although he made many experimental engines, Bob always felt that lapped pistons made the best runners.

Barker .60

DRAWN BY ALLEN POND

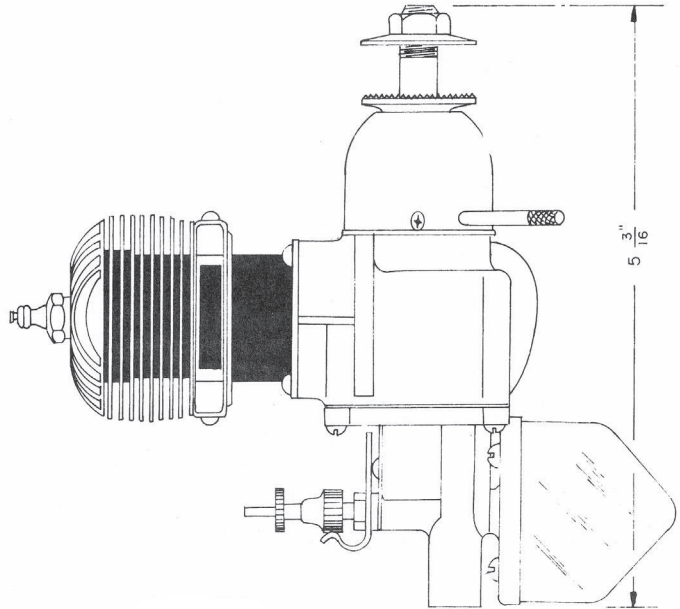
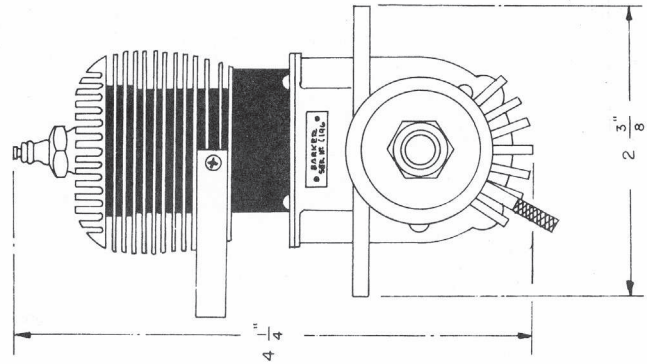
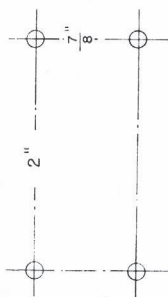

MOTOR OF THE MONTH

Most modelers don't know it, but the Barker engine, this month's subject, was actually produced before World War II in four versions: the Model C, with transparent fuel tank; Model B, with metal tank; and Model A, and the same as the B, but set up for inverted running. The last of the pre-war engines was the Barker Spitfire, which looked snappy with a cast metal tank, not unlike the Syncro Ace engine.

After the Japanese had run up the white flag, with all the money that had pent up during the war, there was a terrific demand for motors, and *right now!* This had been brought on by the tremendous increase in controlline flying with consequent unheard-of prizes, like a full-size Piper aircraft for first place.

All engine manufacturers were naturally interested in cashing in on this sudden windfall, and the Barker Engineering Co. was no exception. One of the earliest advertisements of the new Barker engine appeared in the April 1946 issue of *Model Airplane News*. This advertisement billed the "Great new Barker sensational Man-U-Matic valve engine." Their claim of terrific speed with easy starting interested this columnist.

So there was nothing else to do but invest \$24.50 in a new Barker to see how it compared with the Ohlsson, Super Cyclone, and Orwick .60 engines. Upon inspecting the engine and reading the directions, a definite surprise was in store! The induction system, which the writer thought was a rear disc rotary valve, was actually a disc-driven rotary valve. As several engine collectors have pointed out, this was actually an automatic choke. By that, we mean the following: When starting the engine, the instructions said to revolve the propeller in a clockwise direction until a small click was heard. What was taking place was that the disc was being revolved backwards until only a small hole opened to the intake tube. The columnist soon found that it was difficult to flood the engine and as a consequence, made for easier starting, as per their advertisement.

Once the engine was running, the engine was adjusted for maximum running condition; i.e., advancing spark lever and leaning out the fuel mixture. The engine actually ran quite respectably with this set-up. Then, following the instructions, the writer pushed the button on the intake tube while the motor was running and the disc then turned counterclockwise and opened up a large slot (a la McCoy) to the intake tube.

With such a large volume of gas now being admitted to the crankcase, the engine immediately went to a fast four-cycle. The needle valve then required more adjustment, with the engine coming on stronger all the time.

With a 14x6 prop, the engine outperformed comparable engines such as the Ohlsson and Super Cyclone. Not content with the bench performance, the writer then flew two identical Playboy Seniors, one with a Super Cyclone and the other with a Barker. This was the most pleasant surprise of all, as the Barker version outclimbed the Super Cyclone powered Playboy, which was considered by most as no slouch in getting altitude. Alas, several contests later, the Barker version disappeared and with it, the last of the available Barker engines in the area, as the Barker Co. was succumbing to the advent of the glow plug.

Barker engines had a real touch of class about them, as they featured a nameplate as is done in full-size aircraft engines. The magnesium castings were quite well done, and coupled with a shiny aluminum timer cover and a black enameled head having deep fins and a cadmium plated exhaust, this engine was indeed attractive.

Barker timers were not the easiest to adjust, having 15 parts (Ohlsson has 11). Despite this, very little intermittent spark was encountered when the points were correctly adjusted. The excellent fit between the cylinder and piston generally typified the workmanship of this engine.

For the technically minded, the bore was .9375 inches with a stroke of .875 inches, giving a displacement of .604 cu. in. The overall weight was 11 ounces, including tank. Two castings, both of magnesium, are used in this engine. The steel cylinder and head was integral and blind bored like an Ohlsson .60. The piston was steel, with a tubular wrist pin having aluminum wrist pin pads to prevent scoring the cylinder walls. A ground, machined steel crankshaft was fitted to a bronze bushed crankcase using an Ohlsson type thrust bearing.

In conclusion, the Barker was just another good engine that failed to find popularity with the modelers. Whether it was lack of availability at all hobby stores, the higher price, or the newness of the engine, one or all factors prevented it from competing with the established engine manufacturers. Another good engine that has become an engine collector's jewel.

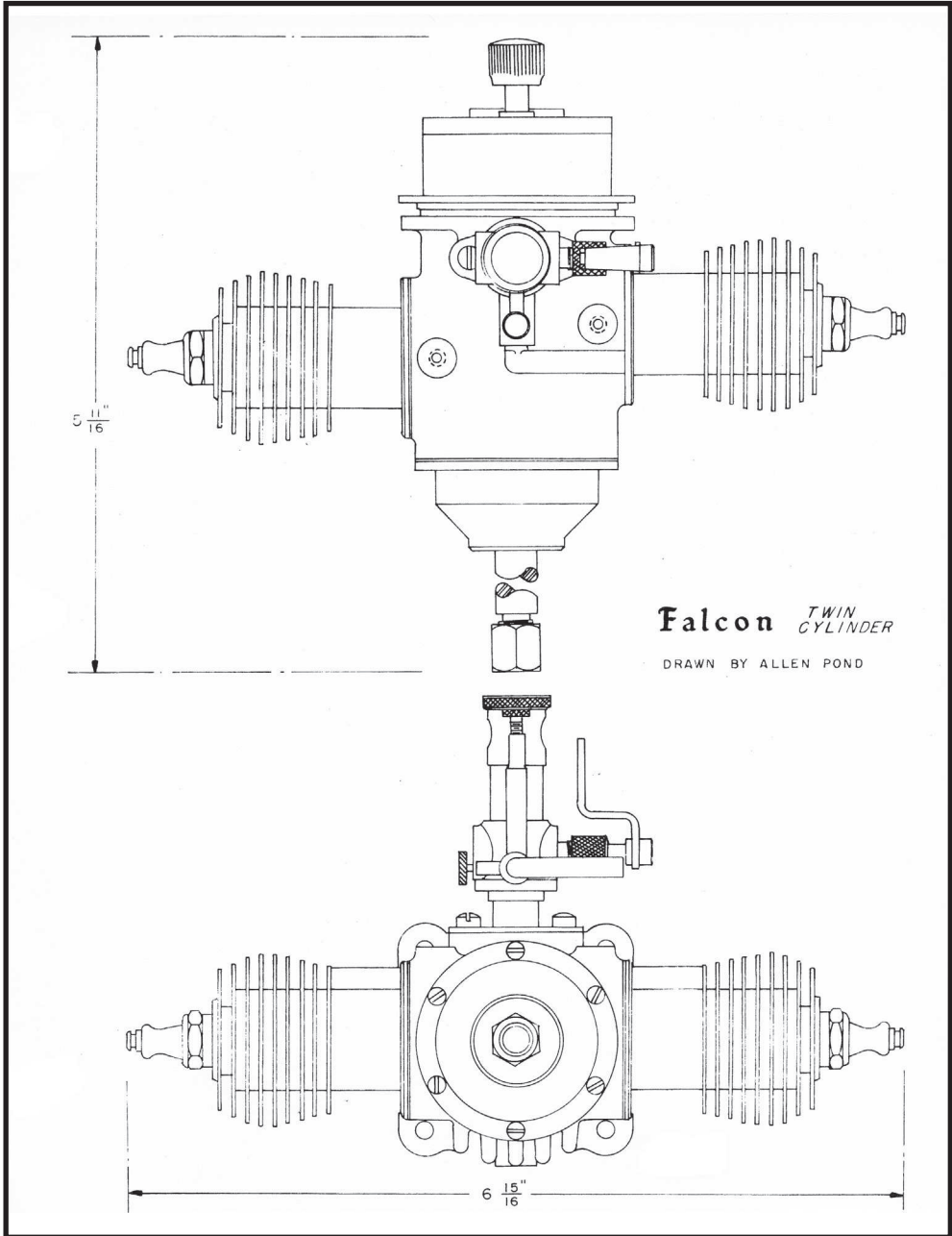

ENGINE OF THE MONTH

This month's subject, the Fergusson Twin (advertised as the "Falcon"), derives its name from the designer and manufacturer, John T. Fergusson. What may surprise most modelers is that the John T. Fergusson Co. was connected with the manufacture of aircraft for the United States Army Air Corps. The main product of this company was sub-components such as struts, landing gears, guy wires, fittings, and other small gear.

For twenty years, this company was associated with full-sized aircraft and earned the title of "Air Corps Inspector in Charge" of no less than five leading aircraft firms.

About 1926, Fergusson became interested in model airplanes as a hobby. Model flying in those days called for extremely light construction, something Fergusson found not to his liking, as models broke rather easily. In place of balsa John tried substituting spruce, mahogany and the like. Of course, this made the model quite heavy, requiring more power. To decrease the wing loading, bigger models were tried until the size was beyond the capability of rubber.

About this time, Bill Brown came out with his sensational Brown Jr. engine that became the model for all others to follow. Fergusson, who was by now convinced that gas power was the answer after the large rubber model fiasco, was not quite sure the single-cylinder engine was the answer.

Fergusson felt that, from an engineering standpoint, two cylinders were more

reliable than one, as there would always be power to carry the propeller over despite a misfire, relying on the prop's weight to carry it through another revolution.

According to the brochure issued by the Fergusson Company, three years were spent on a model engine design. As always, the bugaboo of weight constantly haunted him when considering an engine for models of four or five foot wingspan. With the advent of the large models (such as the KG, Miss Philly, etc.) as dictated by the fuel allotment rules, Fergusson suddenly found the answer with his twin-cylinder engine design. Here was an engine suitable for a ten-foot model that would run with less vibration, deliver more power, and in general be much more reliable than a single-cylinder engine.

Manufactured at first in small lots, the price of production was prohibitive for the average modeler. (Times were tough in 1932!) It was then that Fergusson drew on the talents and advice of two engineers and formed a company to produce engines.

Three engines were designed and put on the market: the "Eagle" (single cylinder), Falcon (twin cylinder), and the Condor (four cylinder). All engines were designed around one cylinder size, to enable the modeler to progress from one size to the next largest.

The engine we're featuring this month (the Falcon) had a cylinder bore of .875 inches and stroke of .625 inches. This gave a displacement of .376 cu. in. per cylinder or .75 cu. in. for the twin. Claims were made for the short stroke as the

main contribution of high rpm and excellent low vibration characteristics.

Fergusson engines feature 4130 steel bar stock cylinders with the fins integral with the cylinder barrel. The transfer port was brazed (like Brown Jr.) to the outer cylinder wall. The cylinders in turn were bolted to the crankcase.

In the machining kits provided by the Fergusson Co., cast iron pistons were provided with an option for aluminum type pistons. The crankcase was machined from a solid steel billet.

The front of the crankcase was fitted with a ball bearing. Ahead of the bearing was a long bronze bearing with annular oil grooves. The rear bearing was also bronze with a felt oil retainer ring.

Ignition, using a 3/8-24 AC Spark Plug, was accomplished by means of a cam and breaker points at the rear of the crankshaft.

Fergusson engines were first advertised in *Model Airplane News* in 1935 after some desultory advertising in *Aero Digest*. Speeds from 2500 to 7500 rpm were claimed, with a weight of 27 ounces (a wee heavy for a .75 cu. in. size engine!). The twin was rated at .4 horsepower and sold for \$35, less propeller. Propellers, incidentally, were also manufactured by the Fergusson Co., but that is another story for later.

All Fergusson engines came finished with red crankcases, black cylinders, and unpainted aluminum, making for an attractive looking motor. All engines came fully guaranteed with no charge for handling. Naturally, if the engine was abused, no engine manufacturer in those days would give an unconditional guarantee.

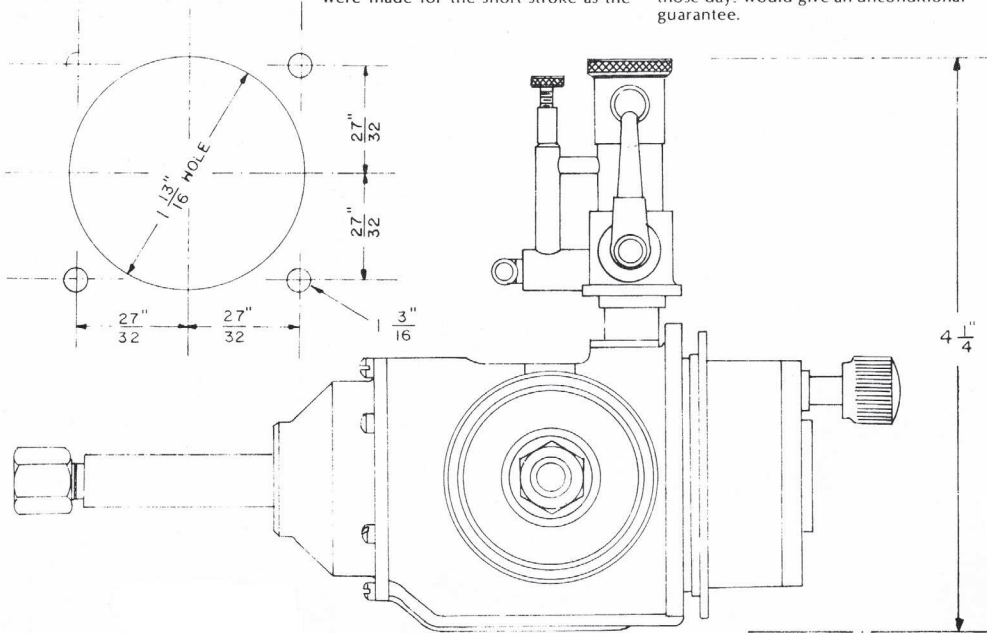

Chunn "Chum"

DRAWN BY ALLEN POND

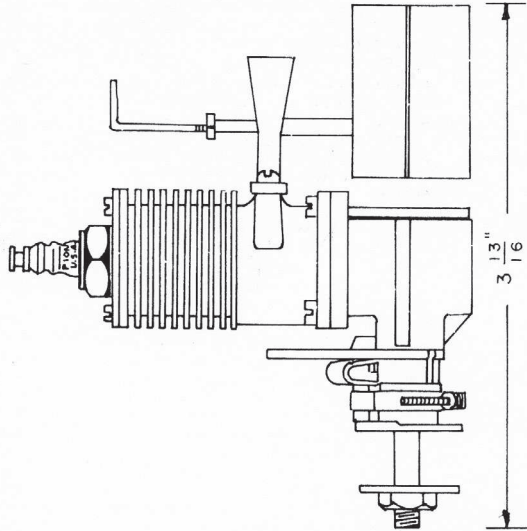
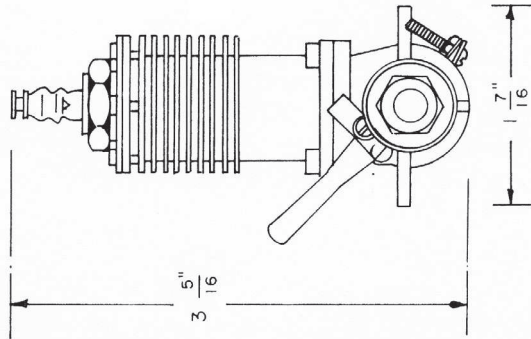
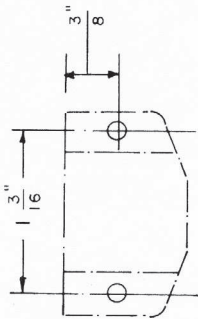

ENGINE OF THE MONTH

This month's Old Timer engine is the Chunn "Chum," second model. The reason for doing the second model first is because this was the only Chunn engine Karl Carlson had on hand to use as a model from which to take measurements.

The Chunn engine was developed by Bob Chunn, who was a barber at the time he started tinkering with model engines. Using the Elf engine as a basis for ideas, it wasn't long before Chunn had produced his own engine based on his idea of what an engine should look like.

His first engine (which we will cover later on) was greatly influenced by the Baby Cyclone fixed timer idea. By 1937, the so-called "redesigned, greatly improved" Chunn engine, Model Two appeared in the advertising pages in the January 1939 *Model Airplane News*. This engine became known as the "Chum." It featured a movable timer which aided greatly to the performance. The timer, with a sand cast body, employed a wipe type point system.

Engines were initially priced at \$17.50 or \$18.50, depending on the particular advertisement you happened to run into. With the demand increasing for small motors, Chunn's second model enjoyed a considerable modicum of success, over several hundred being produced. Not bad for a barber who started operations in the back room!

However, despite President Roosevelt's attempts to prime the economy (the great depression was a real dinger!), a mild recession set in during 1938, with the net result that Bob Chunn was forced to drop his prices (competitors such as Bunch motors were selling at \$10) to maintain sales.

Of course, with profits low and very little capital to weather the recession, Chunn finally had to turn over what he

had left to satisfy the stockholders. Bob Chunn continued in a small shop to produce "specials" and to repair and rework the old Chunn engines, but that's another story.

For those who are technically minded, the bore and stroke of the "Chum" was .625 x .531 inches, giving a displacement of .163 cu. in. The cylinder, of cast aluminum, featured a pressed steel liner. The lapped piston was machined and lapped with two oil grooves. A flat finless head was drilled for a large 3/8 V-1 spark plug. Most all parts were turned from bar stock, such as the back plate (steel) and the connecting rod (bronze). A sand cast aluminum crankcase completed the engine.

Interestingly enough, according to John Krickel, who wrote an article for the early issues of the *Model Engine Collectors Journal*, spark coils were wound in the Chunn shop utilizing a homemade coil winding machine. Credit should be given to an expert German machinist known as Schaeffer who helped immeasurably in the manufacture of the Chunn coils. As with most coils of the day, the Chunn coil used waxed paper insulators between the primary and secondary windings with a waxed paper cover plainly stamped "Chunn."

Not too much can be said about the enthusiasm that Bob Chunn's small engines aroused in Nashville, Tennessee. In those early days, small engines were regarded as a novelty, and even Bob himself was unsure of the market possibilities. Just about the time the demand for small engines arrived, the Ohlsson .23 appeared on the scene. This excellent starting and running engine put many of the small engine manufacturers out of business, and Chunn was no exception.

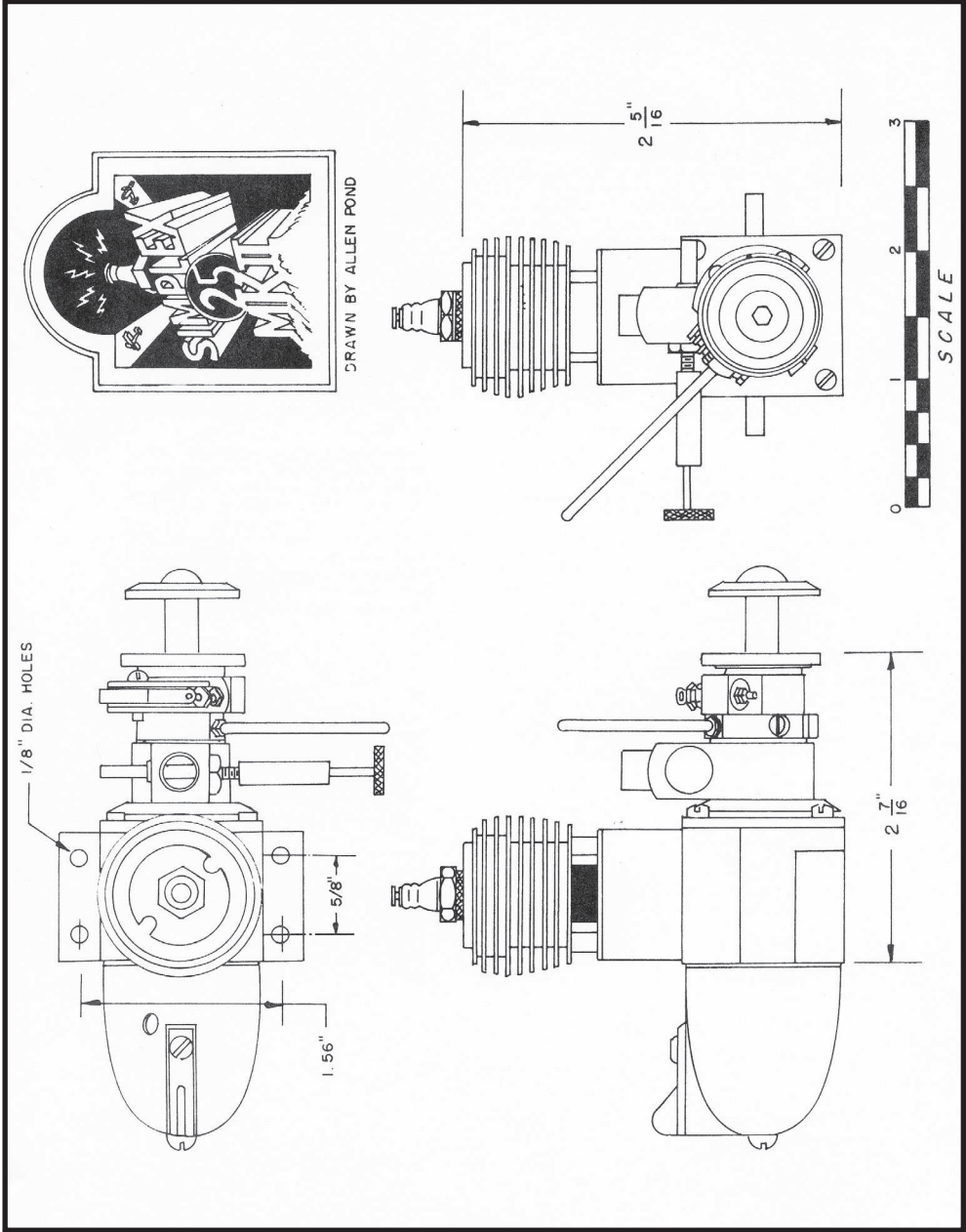

MOTOR OF THE MONTH

For those engine collectors and modelers who have been looking forward to the monthly three-views, we apologize for the lack of them in the last few issues. We had so much to report on the SAM Champs and Old Timer events at the AMA Nationals, we simply ran out of room.

For this month's motor, we have selected a "make your own" designed by Louis Garami. Drawings and instructions appeared as a two-part article in the March and April 1947 issues of *M.A.N.* Called the "Simplex 25," this was about the simplest machine shop project involving an engine that could have been presented. To help the inexperienced would-be machinist, many parts were the same as the Forster 29.

It remained for John Morrill to revive interest in this Garami motor. John built six engines as an experiment to see how they would run. Surprisingly, as predicted by Louie Garami, the engines ran quite well. However, when the engine was used in flight tests, it became apparent to Morrill the Simplex 25 needed more power to compete against the contemporary engines of its day.

So back to the drawing board to improve the power output. As John points out, the intention was not to produce a hot engine, but to make an engine with adequate power, keeping within the spirit of the Old Timer movement.

During the next two months of development, the major changes were altering the port timing, increasing the port openings, elimination of the con-rod/piston ball-and-socket joint, a separate cylinder head in place of the blind bore (popularized by Ohlsson), and a separate phosphor bronze main bearing was substituted for running the crankshaft in the front plate material. The timer proved unsatisfactory, so a new design was made up.

The prototype engine was designated the Mark II Simplex 25 and pleasantly exceeded all expectations. Starting was no problem, and best of all, after four-hours of running time (using a 9x4 Top Flite propeller), the engine ran at 11,000 rpm. With a 10x3-1/2 prop, power output was 10,000 rpm . . . 2,000 rpm better than claimed for Garami's engine!

Of course, bugs always crop up, and the prototype was no exception. The crankshaft would have to be hardened, as the main bearing was galling. To keep the pressed-in crankpin feature, Morrill decided to hard chrome plate the shaft and grind to fit.

With shop drawings now completed, 50 engines were built. Morrill did all the machine work, leaving the finishing (chrome plating, anodizing, and black oxidizing) to other sources. For the benefit of the engine collectors, Morrill states that Simplex engines were numbered as follows: Nos. 1 thru 6, original prototypes; No. 7, Mark II prototype; No. 8 and above, Mark II production run.

For the technically minded, the Mark II Simplex features a displacement of .25 cu. in. with a square bore and stroke of .688 inch. Weight is seven ounces with a clear plastic gas tank. Recommended fuel is 3 parts unleaded gasoline to one part SAE 70 wt. oil.

The engine itself is primarily machined from aluminum; cylinder head, crankcase, front plate, and timer frame. The cylinder is Ledloy steel, mehanite piston, steel crankpin, 2024 T-6 connecting rod, and tubular wristpin retained with wire circlips.

Simplex engines can be obtained from John Morrill, 143 Richmond St., El Segundo, CA 90245. Price is \$160 without spark plug. If you want a plug, this is \$3.50 extra. Be sure to include \$2 for postage and \$1.75 for insurance.

Anderson Vivell Simplex Torpedo Brown Feeney OK Hornet Ball Syncro Elf

Thermite Madewell Bungay Ohlsson Gwin Supercraft Condor Micro Knight Tlush Little Dynamite Viking Bullet

Cobey Waite Deeziil A two wood Phantom Sky Charger Falcon Brat Luxor Golden Eagle Atom Husky Rogers McCoy Ken

VINTAGE ENGINES of YESTERYEAR

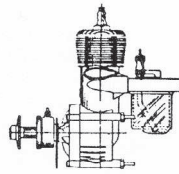
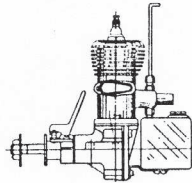
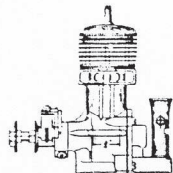

Vol. 2

Fleetwind Trojan Hetherington DeLong Bunch Orwick Forster Molnar M&M

TABLE OF CONTENTS

FERGUSON CONDOR FOUR.....	118
VIVELL 35.....	122
BALL 604.....	124
LUXOR 48.....	126
GWIN-AERO.....	128
HURRICANE.....	130
FLEETWIND.....	132
DELONG.....	134
PHANTOM P30.....	136
HORNET.....	138
ROGERS.....	140
DRONE DIESEL.....	142
KENCRAFT.....	144
BUNGAY 600.....	146
AIR-O DIESEL.....	148
THERMITE 60.....	150
ATOMIC 60.....	152
VIKING TWIN 65.....	154
BUNCH WARRIOR.....	156
ATWOOD TRIUMPH 49-51.....	158
MOLNAR 78.....	160
MICRO 19.....	162
SUPERCRAFT SKY CHIEF.....	164
KNIGHT.....	166
DEEZIL.....	168
SIMPLEX HORNET 19.....	170
SYNCRO BEE.....	172
COBEY-WAITE.....	174
CLEVELAND TOM THUMB.....	176
SKY CHARGER.....	178
TLUSH SUPER ACE.....	180
FEENEY 4 CYCLE.....	182
MC COY 19.....	184
CONTESTOR.....	186
MADEWELL 14.....	188
APEX SKYLARK.....	190

HORNET A.....	192
C.I.E. 10.....	194
MELCRAFT 29.....	196
BAAB-FOX.....	198
PEGASUS.....	200
KRATMO 60.....	202
STEELE'S "R.B." SPECIAL.....	204
VIVELL TWIN 60.....	206
OHLSSON CUSTOM 60.....	208
DIESEL 60.....	210
HI-SPEED TORPEDO.....	212
CANNON 300.....	214
HURLEMAN ARISTOCRAT 48.....	216
PACEMAKER 59.....	218

FERGUSON CONDOR FOUR

2.4 CU. IN. DISP.

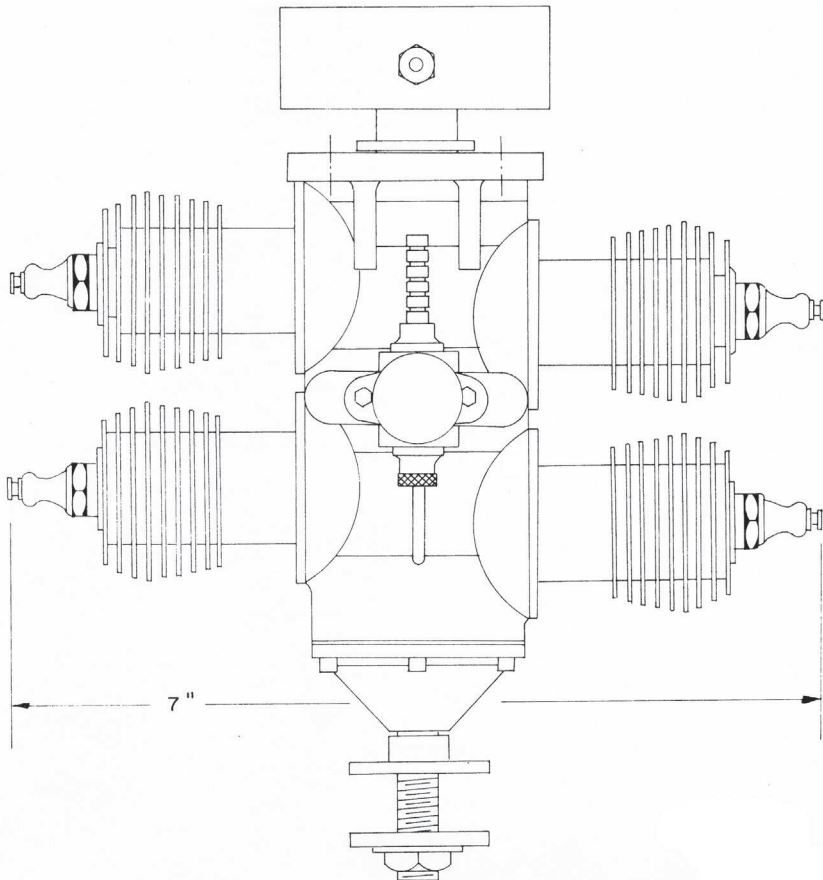
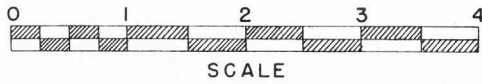

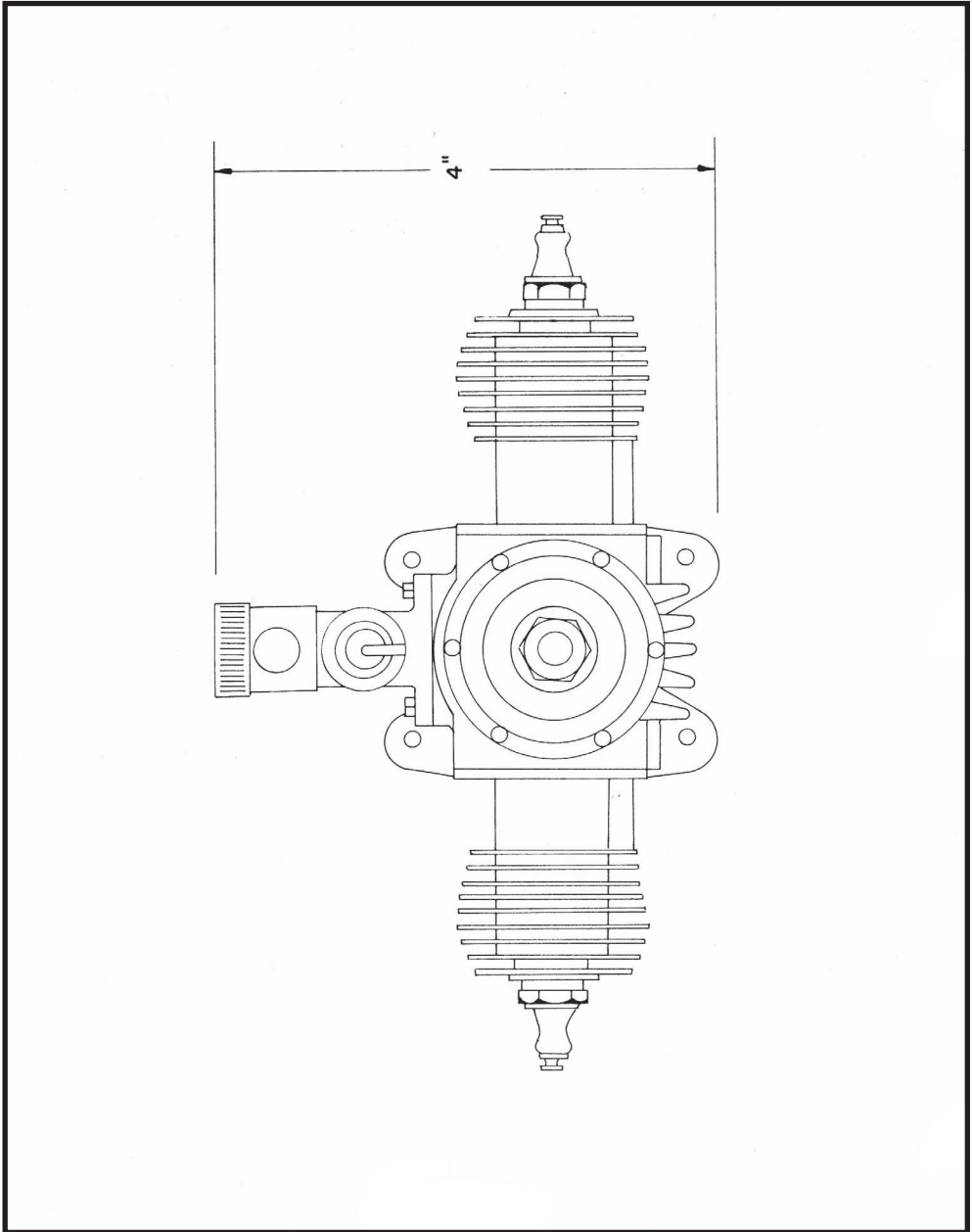

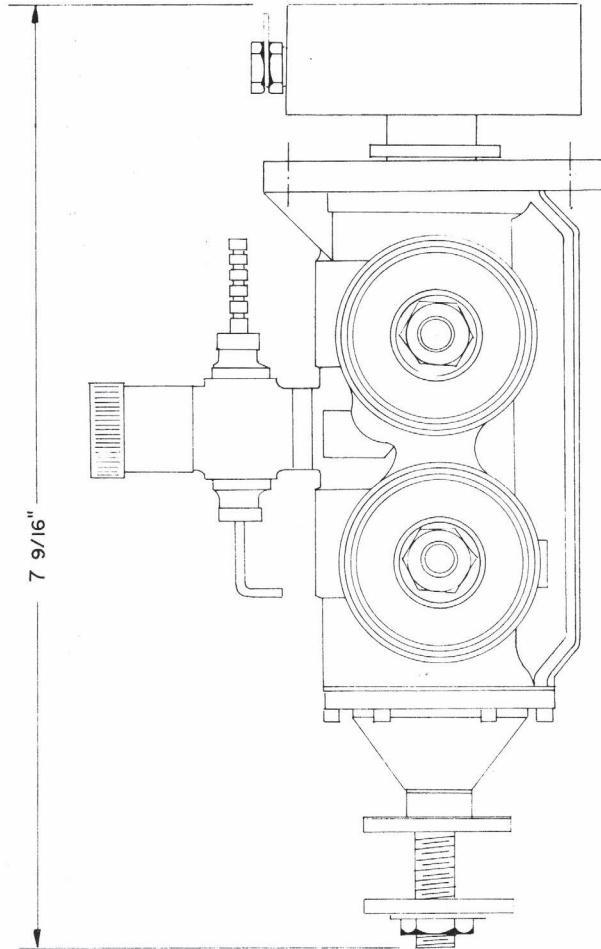

DRAWN BY ALLEN POND

ENGINE OF THE MONTH

As reported in the September 79 issue of **R/C Model Builder**, John Fergusson produced three production type engines for the modeling game. This month's motor is the Fergusson "Condor" Four, which was developed for large model airplanes and boats.

In the interests of keeping production costs low, all cylinders and pistons were alike regardless of the type engine being produced. This made for easy replacement of parts.

Rather than talk about the old manufacturer, we would prefer to comment on the modern producer, Replica Engines, a joint venture of Karl Carlson and Dick Dwyer. As has been reported previously, this firm produces castings for those fellows who like do-it-yourself projects.

Not many readers know it, but most all engines that are published in this column are drawn direct from an engine thought to be complete and most representative of the original. In that line, we are indebted to Karl Carlson who has so kindly loaned us his original to copy.

This particular engine was machined and assembled by John Nuovo of Pittsburg, California. John needs no introduction to engine collectors, as he has made up many engines to order. Among his more well known have been the Atwood Racing series of engines known as Silver Crown, Blue Crown, Red Crown, etc.

Those interested in these type engines are advised that the engines do not come cheap. John is a painstaking craftsman and his work reflects the cost of manufacture. Those who have obtained engines made up by Nuovo highly prize these items, and high asking prices are no surprise.

For those interested in other motors such as the Anderson Spitfire, the Replica Engine Company is gradually making headway. At present, the shop is still undergoing rewiring and rearrangement. There has been considerable speculation that Mark Fechner, a successful engine manufacturing man himself, may join forces with Replica Engines and become their main engine production source. One thing for sure, it can't be for lack of machinery and equipment!

Oivell .35

DRAWN BY ALLEN POND

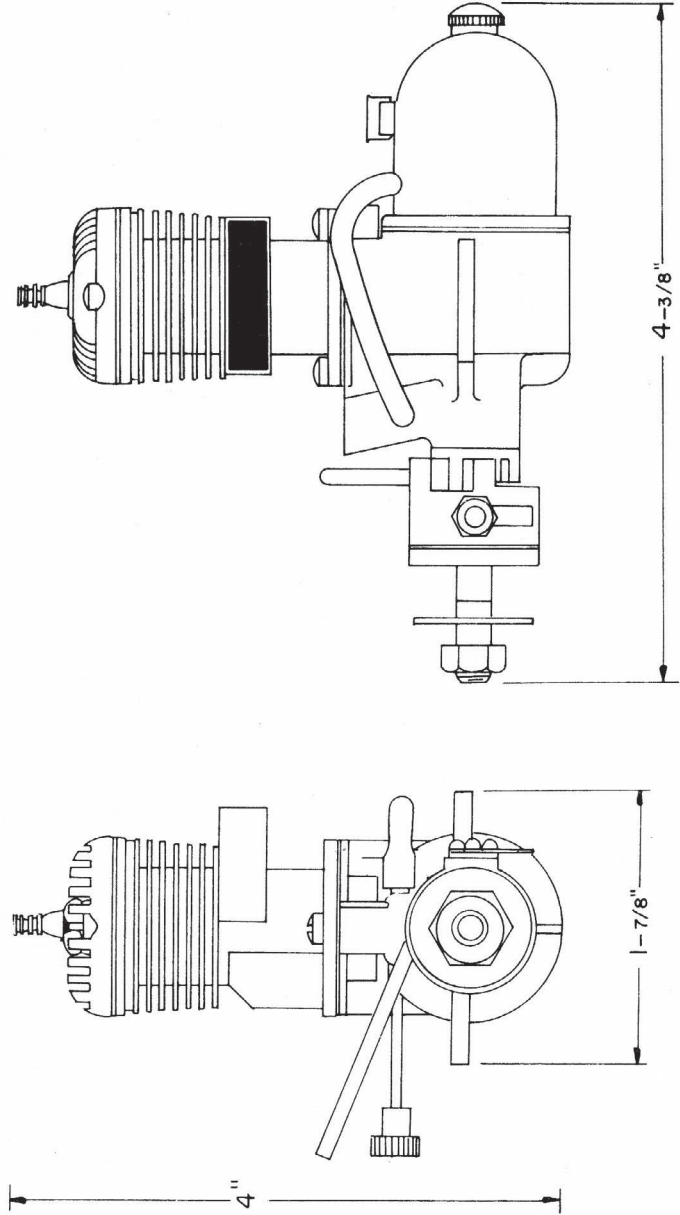
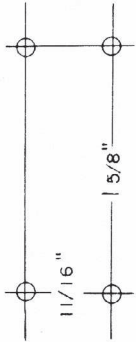

MOTOR OF THE MONTH

Back in the August 1977 issue of *Model Builder*, we ran the Comet .35 as the featured engine of the month. If this and the Vivell .35 seem similar, there is an excellent reason: they were both designed by the same guy, Jack Keener!

As explained in that issue, Jack simply didn't have the money to continue production of the Comet .35 engine. With World War Two going full blast in Europe and the United States on the brink of declaring war, Jack was approached by Earl Vivell, a local hobby dealer. Earl's idea, of course, was to distribute the motor being manufactured by Keener.

The first motor that came out bore a remarkable resemblance to the Comet .35, even to the cadmium plated cylinder. This is generally considered to be the first model of the Vivell .35. This engine was sold all through the war under the guise of "a few engines available."

Having purchased all engine parts and arranged for Jack Keener to stay on, production of engines was assured, based on a nice backlog of parts.

Naturally, the engine underwent several improvements, with the second model having an improved timer assembly and housing. The motor now featured a dull black oxide finish on the cylinder. Cylinder head thickness was also reduced.

According to Don Belote, who wrote a short history of the Vivell engines in a 1964 issue of the *Model Engine Collectors Journal*, there were actually five distinct models, each with varying improvements. Some of the changes included enlarging the bypass and squaring the exhaust ports. In the fourth model, a streamlined metal tank was added to the backplate.

The fifth model (the one we are illustrating) had a higher compression head, angled intake venturi, and the same enlarged bypass and exhaust. (It appears the fourth model was a combination of crankcases from No. 3 that evidently were left over from that model.)

Vivell engines, particularly the large port versions, were good runners. The early models had a tendency to vibrate and were sensitive to needle valve adjustment. The points tended to float at high speeds with a resultant miss. However, this was not noticeable at normal speeds used in free flight models, giving the extremely steady power so desirable in the climb.

Strobatic tests conducted by the *Air Trails* magazine staff in February 1946 stated the Vivell engine turned 8,150 rpm with a ten-inch low-pitch propeller and 7,000 rpm with a ten-inch high-pitch prop. Use of larger props such as a twelve-inch low-pitch gave 7,000 rpm, while the corresponding twelve-inch high-pitch propeller gave 5,650 rpm. Peak speeds were obtained using a ten-inch prop on control line type models.

The Vivell .35 motor featured a bore of .768 and a stroke of .750 in., giving a displacement of .35 cu.in. Motor weight was seven ounces without coil and condenser. For the technically minded, the cylinder was machined steel with a brazed bypass and exhaust stack. The cylinder featured a flange which allowed two Phillips screws to attach the cylinder to the crankcase.

Conversely, the machined aluminum head was held to the cylinder by four fillister head bolts. Piston was of steel (unhardened as of last reports) with oil grooves in the top end and a milled bypass slot in the side of the piston.

The rest of the engine was pretty much of standard production of the day with a brass wrist pin, connecting rod of cast aluminum fitted with bronze bushings, a one-piece crankshaft of hardened steel with the rotary valve milled in the shaft.

A bronze main bearing provided the support for the crankshaft and this was pressed into a permanent mold aluminum crankcase. Back cover, which screwed into the crankcase, was also of the same material. Also of cast aluminum was the timer, an enclosed type. Needle valve was very much like the Universal needle valve being marketed at that time.

The engine was neatly finished off with a light sheet metal tank that fitted into the crankcase cover, being held with a long screw. The unit sold for \$18.50 at that time and was considered one of the better engines of that class displacement. Like all engines that fail to keep up with the competition, the Vivell .35 gradually faded from the competition scene. By 1946 several new models bearing the Vivell name (built by Jim Brown of Little Dynamite fame) made their appearance, but this is another story we will feature in a future issue.

Ball .604

DRAWN BY ALLEN POND

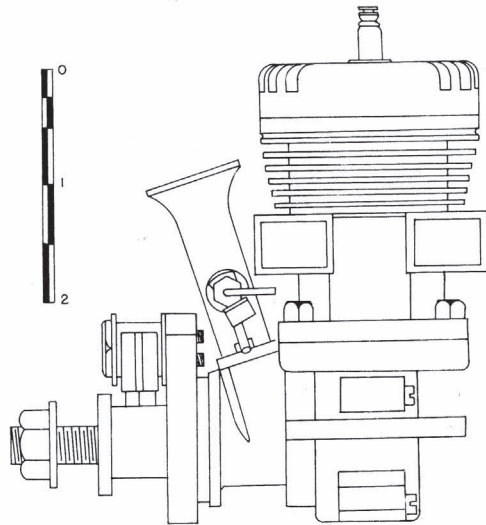
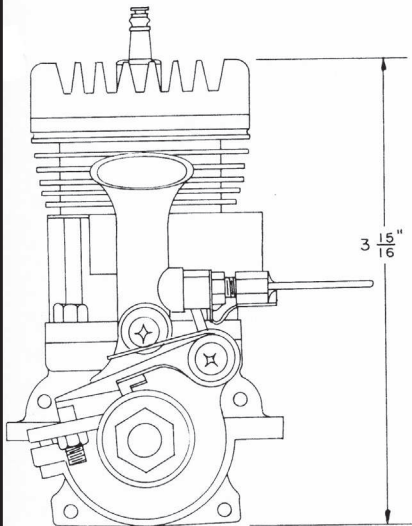
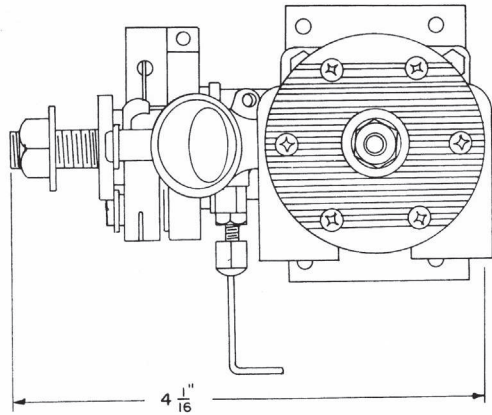
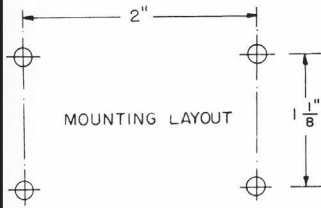

ENGINE OF THE MONTH

It was 1946 and the control line craze was at its zenith, with Ernie Babcock Jr. and Sr. winning fantastic first place prizes . . . such as a full-size Piper aircraft!

The emphasis was on the big motor at this time, so it was no great surprise when a new racing engine, the Ball 604, was announced in the November 1947 issue of *Model Airplane News*.

Built so that the engine could be used in all phases of modeling, i.e. airplanes, boats, and race cars, the promised performance was speeds in excess of 20,000 rpm. The engine was initially priced at \$35.00, which seemed to be the going price at that time for all big .60 engines (Hornet, McCoy, etc.).

The engine advertised was an outgrowth of the original 1946 design, which featured spoke type cooling fins on the cylinder head. However, the final production model, as marketed by B&D Racing Engine Laboratory, P.O. Box 262, Drayton Plains, Michigan, featured machined fins as shown on our three-view.

Of course, all fads either fade out or undergo subtle changes over a period of time that makes the trend for the manufacturer to recognize.

With the astonishing successes enjoyed by the Arden .19 and K&B Torpedo .29 engines, it was no great surprise that most of the subsequent kits and magazine construction articles featured these engines. The real indicator was at the 1948 Nationals, when the Class A and B events enjoyed twice the entry of Class C and D models. And all of this before the 1/2A engine craze!

Well, it wasn't long before the price on the Ball engine was dropped to \$29.95 in the June 1948 *Model Airplane News* issue. Although designed and still supplied as an ignition engine, the advertisement tried to take advantage of the new glow plug development by stating "the engine operates to perfection on glow plug ignition."

The handwriting was now on the wall. Only those .60 engines such as McCoy were able to survive the tremendous competition for the modelers' pocketbook. In the April 1949 *Model Airplane News*, the price was again dropped, this time to \$21.50. This was a last-ditch stand, as advertising in *Model Airplane News* ceased for all practical purposes in the August 1949 issue.

The engine from which we have produced this three-view was kindly loaned by Dave Brodsky, a relative newcomer to the collecting game who is rapidly gaining an enviable reputation and collection to go with his fair dealing. This particular engine was in excellent shape and looked like it could run right now!

For the technically minded, the Ball engine featured a displacement of .604 cu. in., a size pitched for the model race car fraternity. With a bore of .924 and stroke of .900, the compression ratio was a startling 10 to 1. Initial performance claims were 1.1 hp at 20,000 rpm. Weight of the base engine was 15 ounces (seems like all hot .60 engines were in this weight bracket). Notable features of this engine were the double bypass, double exhaust porting, rotary inlet shaft, double ball bearing supported crankshaft, aluminum piston, and lightweight connecting rod. All in all, a well-built engine that failed to catch on in those late fabulous forties.

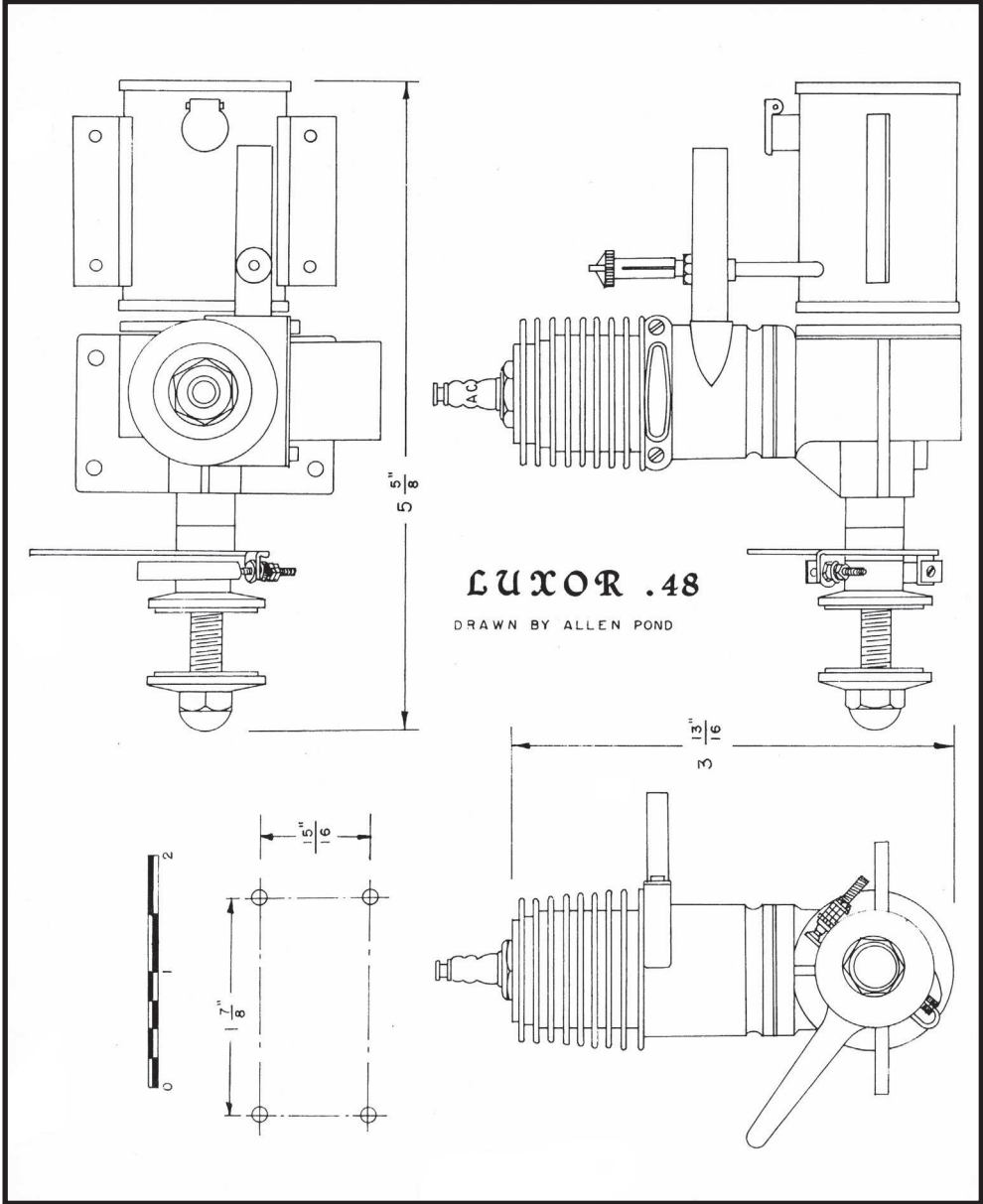

MOTOR OF THE MONTH

This month's motor is truly a rare one; one, this columnist will bet, that 50% of the engine collectors are unaware of. The writer is indebted to Karl Carlson for the use of his rare motor (complete with motor mounted on wood skids similar to a Brown Jr.) and to Dick Dwyer who supplied the information sheet written by Dwight Hartman.

The Luxor engines bear a very marked resemblance to the popular Brown Junior motor; however, the engine we are featuring is a .48 cu. in. displacement. Actually, there were two sizes of Luxor motors built, the smaller being .30 cu. in.

Designed and built by Stephen R. Feiler of 451 Lake Avenue, Bridgeport, CT 06605 (present address), only one of the smaller engines was actually completed by Feiler. Later on, Dwight Hartman acquired parts for 14 more of the .30 size Luxor. Hartman later put these together.

Feiler manufactured 36 of the .48 size Luxor engines, of which 33 were sold through the Bridgeport Model Shop during the summer of 1939. With sales at a very low rate, it was no surprise when manufacture of these engines was discontinued.

The Luxor engines feature a cast aluminum cylinder head and crankcase, utilizing two machine bolts for attachment. For those who want the exact specifications, the .48 has a bore of 7/8 in. and stroke of 13/16 in., giving a cubic inch displacement of .48.

Continuing with the specifications of the Luxor motor, the rear crankcase covers were turned from 245T aluminum. Installation and removal were

facilitated by two spanner wrench holes drilled in the cover. A steel liner of heat treated 4140 steel was used for both engine designs. Pistons were cast from cast iron, machined and ground to a lap fit with the cylinder liner. No rings were employed. The 4140 steel provided the strength for the crankshaft counterbalance. The wrist pin was also made from drill rod. As with most motors of the day, the crankshaft bearing was a bronze bushing.

The engine came mounted on a wood skid quite reminiscent of the early Brown Jr. motor packaging. A Champion spark plug and Smith "Firecracker" spark coil formed the basic ignition components. The timer featured construction of 1/16-inch brass stock and tubing with an adjustable stationary point.

To round out the assembly (and again, make it look like a Brown Junior), a tinplate gas tank of 2 oz. capacity was provided on the wooden skid. The tank was neatly fitted with a Gits filler cap over a 5/16-inch fill tube.

One interesting feature of this engine was the provision of knurled faces on both the propeller drive and prop washer to insure a good grip on the propeller. Only the prop drive was splined to the crankshaft, and the rear face was machined for the timer cam flat.

No performance figures are available on this motor; however, the motor appears to be well made. As pointed out before, the look-alike motor offered nothing new except for displacement size, so was known only locally, never gaining national recognition.

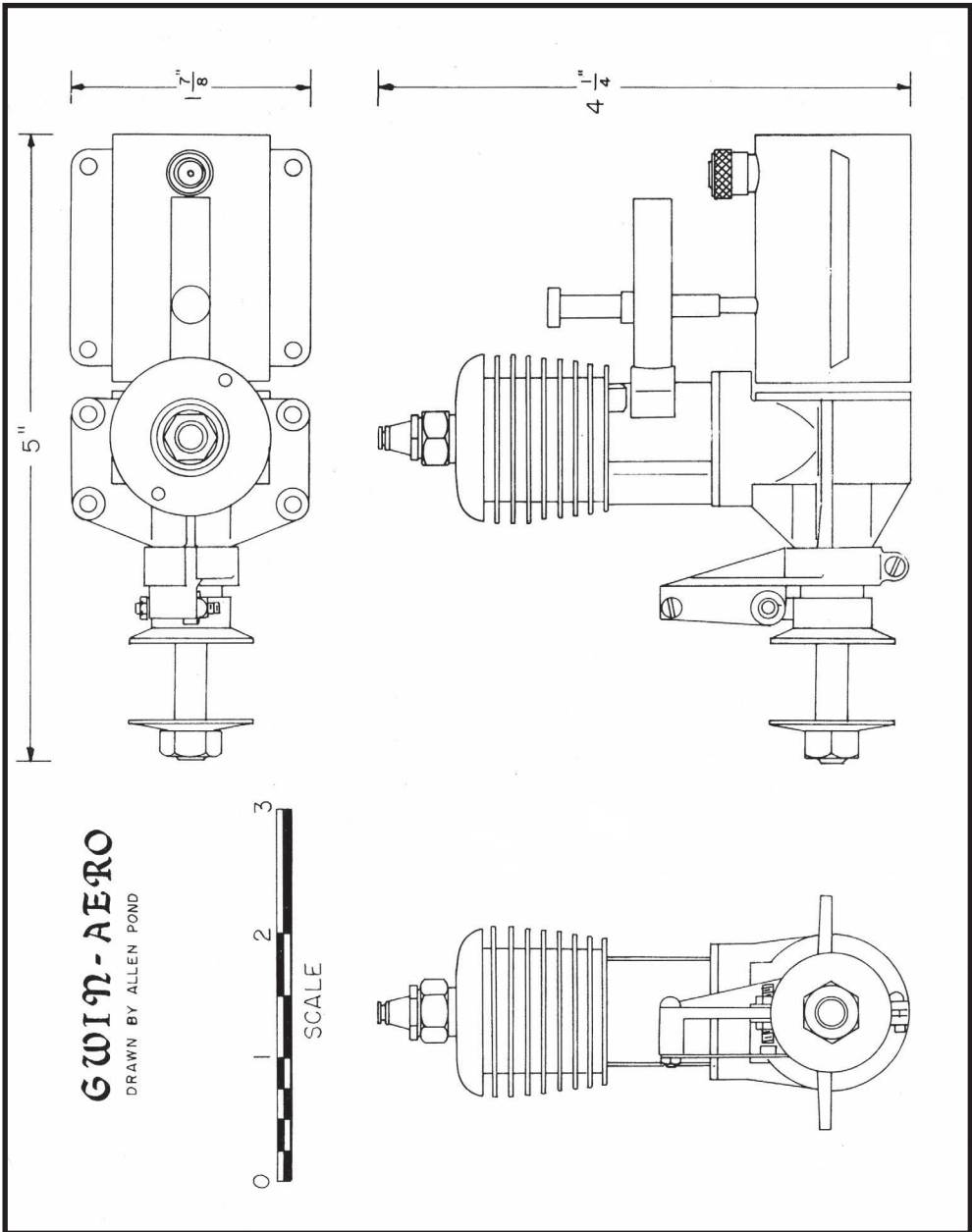

ENGINE OF THE MONTH

The origin of this month's engine, the Gwin-Aero, is one of those things that has been lost in antiquity, but it has been pretty well determined that the engine was originally manufactured in Indianapolis, Indiana. With Danner Bunch dead, there seems to be no way to actually pin this down.

When the first advertisement came out in June 1936 issue of *Model Airplane News*, the size was given as bore and stroke of 13/16 inches. This gave an initial displacement of .42 cu. in. This was followed rather quickly by an engine review article in the November 1936 issue of *Flying Aces*.

For some reason or another, the manufacturing firm name has never been published, as it appeared that Bunch wanted the engine as his exclusive. When first marketed, the engine was sold jointly by J.D. Bunch and Polk's in New York, but very shortly thereafter, all manufacturing was transferred to the West Coast under the name of Bunch Model Airplane Co., located first on Hoover St. (two addresses) and later on McKinley St. in Los Angeles, California.

As noted in the *Flying Aces* engine review, the Gwin-Aero was brought out for bench and flying trials, then returned to the shop for some needed improvements. Most of these were minor and included an aluminum tank, aluminum spinner, and a much desired ratchet system for the needle valve adjustment. The reviewer took particular notice of this feature, as this stopped that annoying habit needle valves have of changing settings under engine vibration.

One of the more striking features about the original production version of the Gwin-Aero was the one-piece aluminum cap which formed the head and fins. This outer aluminum cylinder then screwed down the entire length of the inner steel cylinder tube. Another advanced feature for those days was the adjustable timer points, which were easily accessible. This was one of the faults of the early engines, where the manufacturer took the viewpoint that the less fooling around with the ignition timer, the better.

The Bunch Model Airplane Co. was headed up by J. Danner Bunch, with Howard Broughton and Jim Cain having titles of Project Adv. Mgr. and Production Engineer respectively. The initial price of the Gwin-Aero was \$17.50, complete with coil and condenser.

It didn't take the Bunch boys very long to start making changes once the engine

was produced in L.A. The basic Gwin-Aero engine was now called the Mighty Midget, based on their slogan for the Gwin-Aero: "A midget in size and weight; a giant in power and stamina." This engine was offered both in assembled and kit form.

To really confound the modelers (and later the collectors), the Gwin-Aero engine was again put out, this time with a side exhaust stack. Size of the engine was increased to .45 cu. in., resulting from an increase of the bore to 7/8 of an inch. In 1937, more changes were made, the biggest being the introduction of rings instead of the carefully fitted piston. This change was also reflected in the Mighty Midget. If not thoroughly confused by now, consider the Tiger-Aero, which was a follow-on development of the later model Gwin-Aero featuring very large (comparatively) bypass porting, oversize intake tube, and better exhaust system.

When first introduced on the West Coast, Bunch engines were immediately accepted, as the emphasis was on the small model for the precision type contests being held in California. Compare that with 30-40 years later, when the big free flight model is now king in California and other western states where huge flying fields are available.

Bunch motors were very much in demand, to the point that the original Gwin-Aero engine sired a complete line of Bunch motors that included the Mighty Midget, Tiger-Aero, Warrior, Mighty Marine, and Speedway. Later on, engines were produced for Cleveland Model Airplane Co., called the "Tom Thumb," which was later taken over by Bud Warren in California.

In summary, Bunch engines were good running motors that were rated at 1/5 hp (same as the .60 cu. in. Brown Jr.), with rpm figures running between 7,000 to 7,500. The writer owned an original Gwin-Aero, and it was always his contention that when the Bunch firm dropped the lapped piston in favor of the ring version, they cheapened the engine. Little did he know this was to become the standard type piston arrangement 10-20 years later!

Hence, it was not surprising that the Bunch motors held most of the existing airplane, boat, and rail car records. They were great for control line flying in the early days, particularly in combination with the Jim Walker Fireball. Ah! Those were the days when life was a bit simpler from a rule standpoint. . .

HURRICANE

DRAWN BY ALLEN POND

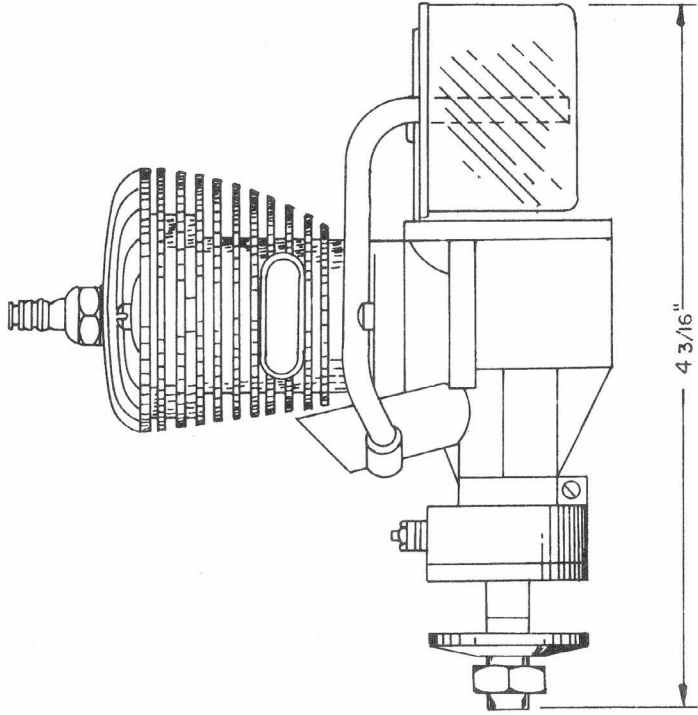
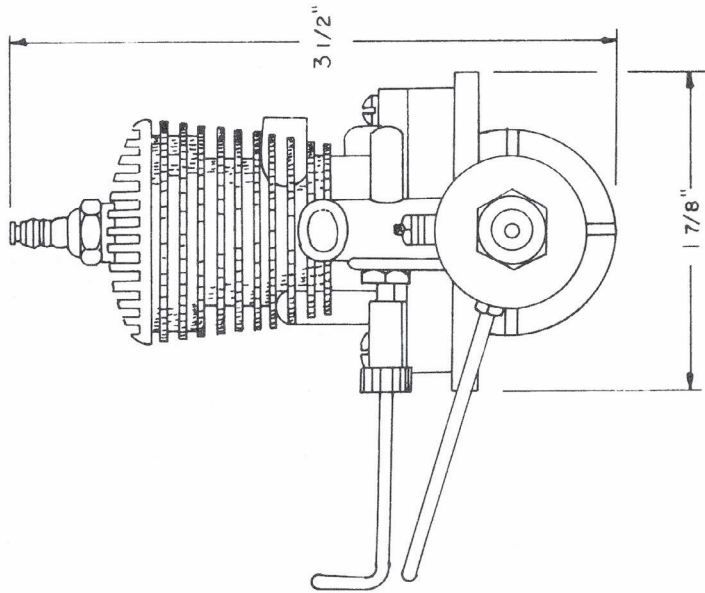
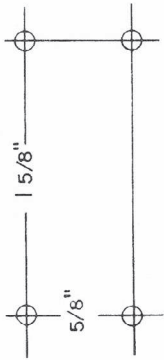

MOTOR OF THE MONTH

Most all of the engines featured in this column have been American designs, produced by U.S. manufacturers. This time we are featuring the Hurricane, an engine produced in Canada.

Hurricane engines (of which there were quite a few variations) were the brainchild of Ray Hunter, a quiet and unassuming man. Ray's background consisted of being trained as a journeyman machinist. His interest in models soon led him to tinker with gas engines in the late thirties.

Ray built a few home-brew type engines but it was not until he took a page from the Forster .99 engine brochure and actually produced one of these large engines from scratch, including all castings and machining, that he had a really successful engine.

Convinced that he now had the know-how for producing engines, Hunter was actually able to obtain an Education Priority to purchase critical wartime materials for the manufacture of model airplane engines.

Of course, on the first several models, considerable expense was involved during the learning process. The first Hurricane motors were produced by the lost-wax method (known as investment casting). It wasn't long before Hunter went to die castings to reduce costs.

The engine we are featuring this month is the fourth version, the Mk. II type, where the molded plastic tank on a bracket was replaced by a steamlined tank, forming a completely sealed unit.

Hurricane engines came out during a time (World War II) when new motors were extremely hard to find. This writer, of course, had to be the first on his block to have one. Running the engine presented no great problems, as the engine was very similar in shape and size to the very popular Ohlsson .23. Starting and running characteristics were remarkably alike! It was a great substitute until

the close of the war when the U.S. manufacturers, notably Ohlsson & Rice, got going full blast again on engine production. This firm, in producing extremely reliable engines, ran many of the smaller engine manufacturers (including Hunter) off the market. When the O&R firm dropped its price by half when competition starting getting a little stiff, it really did in those manufacturers that were barely hanging on.

For the technically minded, the Hurricane 24 had a bore of 11/16 in. and a stroke of 21/32 in., giving an actual displacement of .287 cu. in. Weight of the base engine assembly was five ounces. Hurricane motors for the most part were made of cast magnesium parts (head, cylinder, and crankcase). Crankshaft was of one-piece unhardened steel with a small size counterweight. Main bearing was made of bronze alloy and press fitted to the crankcase.

The piston was machined from mehanite iron, and the first models featured a bronze alloy wristpin. This was found inadequate and the later models such as the Model 4 featured hollow drill steel for wristpins. Liner was machined from steel with a milled slot for the bypass cast integral in the cylinder.

Rotary valve engines were quite popular in this immediate post-war era and the Hurricane engine reflected this trend. Enclosed timer points as popularized by Ohlsson were employed. A V-3 type plug was recommended for best performance.

Strobatac tests, as run by *Air Trails* back in 1946, revealed that the Hurricane ran best with a 10x4 propeller at 7,500 rpm. When using a 10x6 prop, rpm dropped to 6,300 rpm. The *Air Trails* engine test group reported the Hurricane motor was one of the steadiest running engines tested to date.

Fleetwind

DRAWN BY ALLEN POND

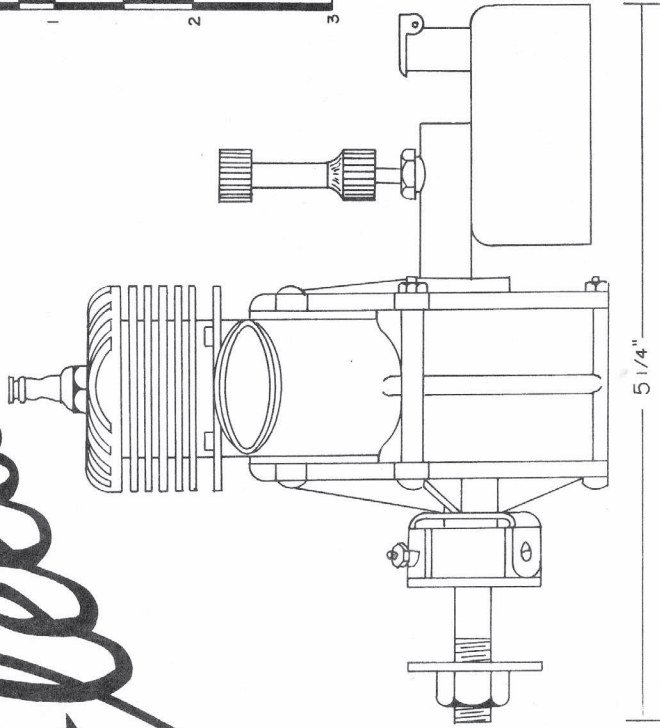
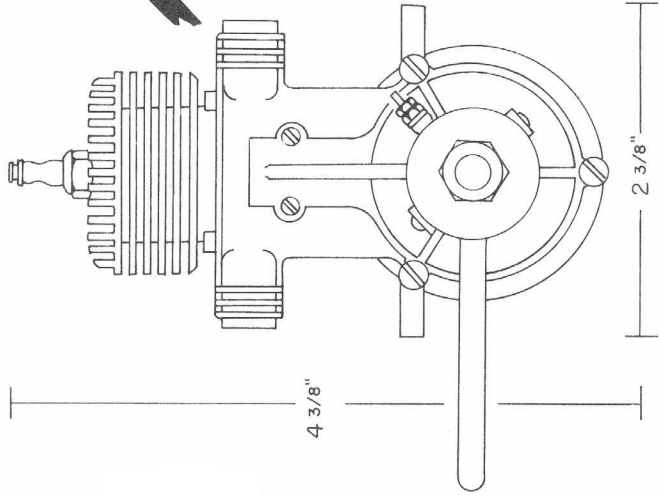
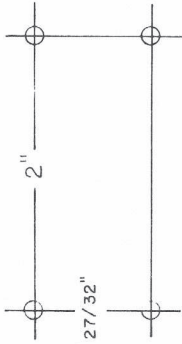

ENGINE OF THE MONTH

In trying to trace the ancestry of old engines through advertisements appearing in the old model airplane magazines, one can easily get tripped up as some engine manufacturers advertised in only one magazine!

Such is the case of this engine of the month, the Fleetwind 60, as produced by the Hoof Mfg. Co., then located at 6543 S. Laramie Ave., Chicago, Illinois. The initial advertisement of the Fleetwind appeared in the March 1946 issue of *Air Trails*, featuring a full page (and those old *Air Trails* pictorial magazines were large pages!) extolling the virtues of this new engine. Credit for development of this engine has generally been given to V.S. Jennings.

After two consecutive full-page advertisements in *Air Trails*, the advertising was abruptly dropped in favor of a photo appearing with a dealer/distributor, the first being Gene Robertson's in Charlotte, North Carolina. *Model Airplane News* finally broke through with an advertisement by Ace Model Shop, featuring the Fleetwind in the May 1946 issue.

Advertising by various distributors still followed with R&H Hobby crafters of Chicago, Illinois, featuring the Fleetwind in their August 1946 ad in *Air Trails*. In an effort to generate sales over the Christmas holidays in the December 1946 issue of *Air Trails*, the Hoof Co. came out with the idea of a complete mount with a complete ignition system (designated Model E-2) which consisted of a 5 x 6-inch plywood base with suction cups to hold the mount on any table, box, etc. This item sold for \$29.75 as compared to the unmounted version less coil and condenser for \$24.75.

Advertisements were far and few between thereafter, with only American Hobby Center carrying the Fleetwind on their list of available engines. In August of 1947, the price was dropped to \$19.50 in an effort to spur sales, but to no avail, as the last mention of the Fleetwind was in the February 1948 issue of *Air Trails*. Another engine that succumbed to the tremendous competition for the .60 size motor market.

Many of the engines that came out after the war were the fertile brainwork of many engine designers who had four years to think up novel ideas for producing a better engine with subsequent additional power. Among those, like the Barker with Manumatic valve, Melcraft with a front ram induction, etc., the Hoof engine was quite innovative in the method of removing engine parts.

The dual bypass covers offered a new method of removal. Another feature was the removable cylinder head and barrel. This was removed simply by loosening the four hexagonal head bolts. Instructions say, do not remove

the bolts as they are mounted in the crankcase. After loosening the bolts, simply twist the cylinder, and the whole assembly pops off. Of course, a special wrench was provided for the bolts. However, this did not prevent the modeler from making his own wrench from a nail file. This interesting "bayonet" type cylinder removal only required a quarter of a turn to lift it from the crankcase.

As if this wasn't enough, the Fleetwind motor also featured removable front and rear crankcase covers, the front carrying the crankshaft and rear cover having the rotary disc valve attached.

Actually, the engine was self-defeating, as so many parts required constant attention to keep everything tight to insure good running qualities. Irwin Ohlsson found this fault in his early Miniature and Gold Seal engines, where removable bypass cover plates could be over-tightened, hence warping the covers.

For those interested in the fabrication of the Fleetwind, the cylinder barrel, and head (one piece) was machined from steel, as were the piston and crankshaft. The crankcase, bypass covers, connecting rod, and timer housing were made from aluminum. Incidentally, the connecting rod was riveted to the piston, eliminating the need for wrist pin pads. (Strange, with so many other parts removable.)

The bearings were made of bronze, and the gas tank was made of light sheet metal with a light sheet metal cover pressed into the tank. The gas tank was held in place by hexagon nuts screwed over the needle valve body and locked onto the intake tube.

Performance figures were not the most encouraging to the modeler looking for the best available power plant. With a cylinder bore of 15/16 inch and 7/8 inch stroke, giving a displacement of .60 cu. in., and weight of 12 ounces bare, the engine was rated at .35 to .40 brake hp by the Hoof people. Claims were also made of 10,000 rpm using a 13-inch diameter propeller with a 3-inch pitch.

Strobatac tests by the *Air Trails'* personnel in charge of the engine analysis found the engine only turned 6,500 rpm using a standard 14 inch F/F propeller. Using a high-pitch 12-inch prop, performance was increased to 7,600 rpm and finally with a 10-in. dia., 9-in. pitch prop, the best rpm obtainable was 9,600. However, at the top end, the needle valve was noted to be quite critical, as the points had a tendency to float. It was generally conceded that a heavier spring or augmenting spring, such as produced by Bunch, would eliminate this problem.

Fleetwinds: Where are they all now? You'll have to contact your local engine collector as this is where most of them ended up.

DE LONG

DRAWN BY ALLEN POND

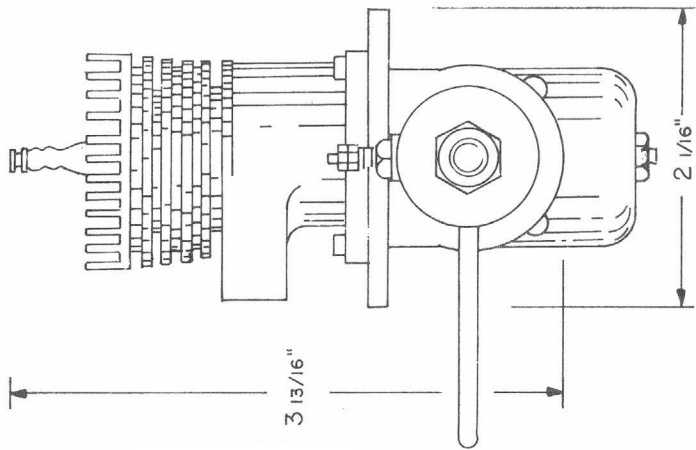
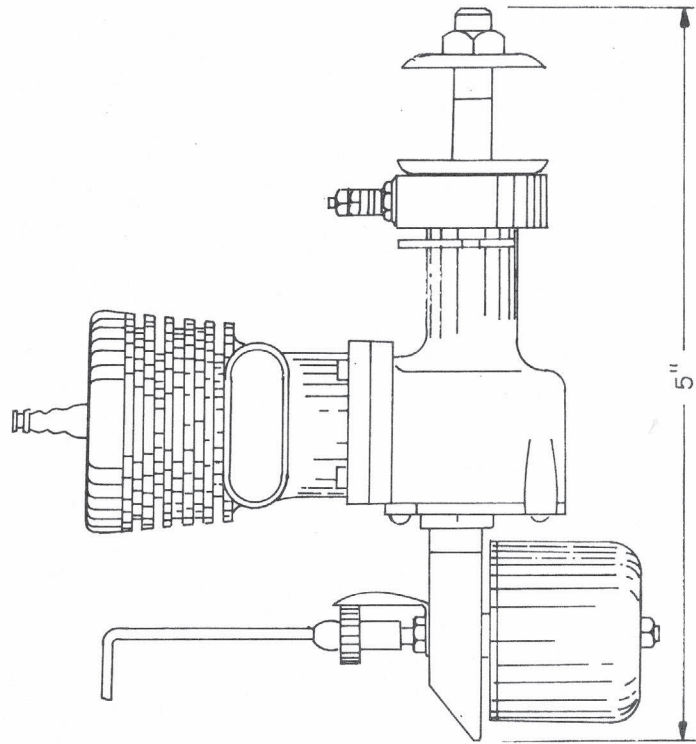
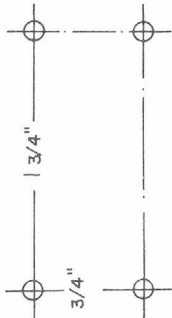

MOTOR OF THE MONTH

Of all the engines that came out right after World War II, the Delong .30 (as manufactured by Super Motors, 2093 E. 19th St., Cleveland, OH) appeared to be the answer to the prayers of the Class B contestants. At the beginning, Delongs were credited with winning all the C/L speed events, then into free flight, where they started scoring well.

With all this publicity, everyone, including this columnist, had to have one. Sales of Delong engines skyrocketed until it seemed this was THE Class B engine. It was then that the columnist discovered, like a lot of other fellows, that the Delong engine they had purchased did not perform like those championship figures they had been reading about. When the facts came to light, it was found that only a specific few had the "hot" ones to go out and set records.

One of the big problems with the Delong motor was that you could never break it in (somewhat like the Veco .45). This reporter can remember Joe Bilgri trying for hour after hour with no results. It wasn't long before the bubble broke and the Delong engine was discarded in favor of Torpedo and McCoy engines.

Delong engines started very auspiciously in small advertisements appearing in *Air Trails* and *Model Airplane News*, February 1946, with four speed contest results running from 92 mph to 100 mph. That really knocked the boys for a loop! (Incidentally, the Delong .45 and .60 were also mentioned, but no real production was ever undertaken.)

By December 1946 the highwater of sales was arrived at with full-page ads

extolling the virtues of the engine and the victories scored at the '46 Nationals. To keep things rolling, the original price of \$24.50 was cut to \$19.50. However, it was only a matter of time, as the K&B Torpedo was making itself felt more and more at the contests.

Large scale advertising in all major model magazines abruptly ceased in May 1947. Ironically, that was the issue that *Air Trails* featured the Delong in its Engine Review. After that the only mention of Delong motors was in one-line ads such as carried by Four Star Model Builders Supply of Schnectady, New York. It was all downhill from then on.

The Delong was a well-made engine of the rotary disc type intake. With a mehanite (iron) cylinder sleeve and a steel alloy piston, it was difficult to get the engine in top running shape. One needed a good honing machine, and of course most of the modelers in those days did not enjoy this luxury.

Delong motors had a bore of .750 in. and a stroke of .680 in., giving a displacement of .299. Weight of engine was eight ounces with a rating of 1/5 hp. An 8,000 rpm claim was made using an 11x9 or 8x10 propeller. The strobatac tests run by the *Air Trails* test section revealed 7,500 rpm with a 10x8 propeller, 9,200 rpm with 9x8 Mercury prop, and 11,000 rpm with an 8x10 Hi-Thrust propeller.

In summarizing the Delong engine, it was a well-made motor but like many of its contemporaries, failed to keep up with the progress of other engine manufacturers, notably K&B, McCoy, and Ohlsson & Rice. The years 1947 and 1948 brought out a lot of new engines, and at the same time saw the demise of some of them.

P H A N T · P 30

DRAWN BY ALLEN POND

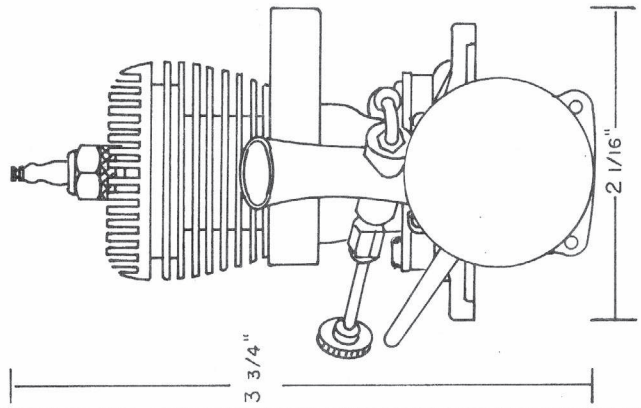
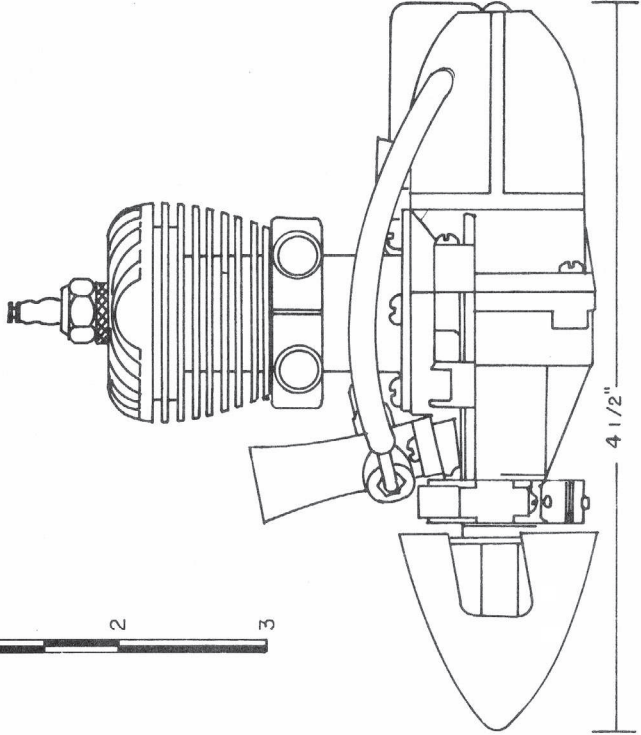
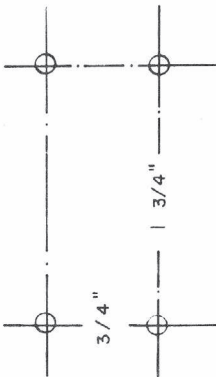

ENGINE OF THE MONTH

This columnist is willing to bet the average modeler is not aware of the tremendous talent, ability, and prolific output of William W. "Bill" Atwood, model engine man supreme.

Just about the time World War II broke out, the advertisements for Atwood designed motors filled the model magazines. After getting away from the Curtiss-Wright Institute in Glendale, California, where Major C.G. Moseley ran things (Baby Cyclone and Super Cyclone), Bill immediately went into production of a series of front rotary valve engines. Among these were the Hi-Speed, Phantom, Bullet, and Torpedo (yes, the Torpedo of today owes its existence to this one). Not content with this, Atwood had a flock of .60 size engines known as the Red Crown, Silver Crown, etc., about four boat engines and one aircraft engine. In between, he found time to come up with the Atwood Champion.

This month's engine, the 1941-1946 version of the Phantom, known as the Phantom P-30, is another Atwood engine that became the property of someone else. It certainly was amazing the way Bill could design an engine, put it in production, and then promptly sell off the design and manufacturing rights.

Although the Phantom engine dates back to 1938 (we'll run the old engine one of these days!), the complete re-design in 1941 was called the Phantom P-30. One of its claims was that it was the first engine to feature the "impinging column."

The new 1941 Phantom featured a split crankcase, cast of aluminum in two halves. The exhaust stacks were "clamp-on" type, this style being carried over to 1946 with a change in shape from square to dual exhaust. The entirely new design featured a long stroke, small bore combination. This "new" principle of bypassing was claimed to give at least 20% more power. The square valve was supposed to increase power by another 10%. We didn't know how good we had it in those days!

The P-30 was a typical good-looking Atwood engine with features like the needle valve angled back to clear the propeller, a dual method of mounting the engine (beam or radial), and clear plastic gas tank. Also, claims were made that the new patented principle of bypassing to eliminate the piston baffle was the better way to go.

Phantom P-30 engines featured a bore of .715 in. and stroke of .750 in., giving a cubic inch displacement of .295. The original weight in 1942 was listed at 5-1/4 ounces but the lightweight Dow metal castings proved to be entirely too weak, so 1946 saw the return of aluminum castings with a consequent increase of weight to 7-3/4 ounces. Horsepower rating was 1/5 (same as a Brown Jr!).

Strobatac tests as run by the *Air Trails* test division showed the P-30 turned 6,700 rpm with a Flo-Torque 12-inch low-pitch prop, 7,500 rpm with a Ritz 11-inch medium pitch, and 6,800 rpm with a 10-inch Hi-Thrust high-pitch prop.

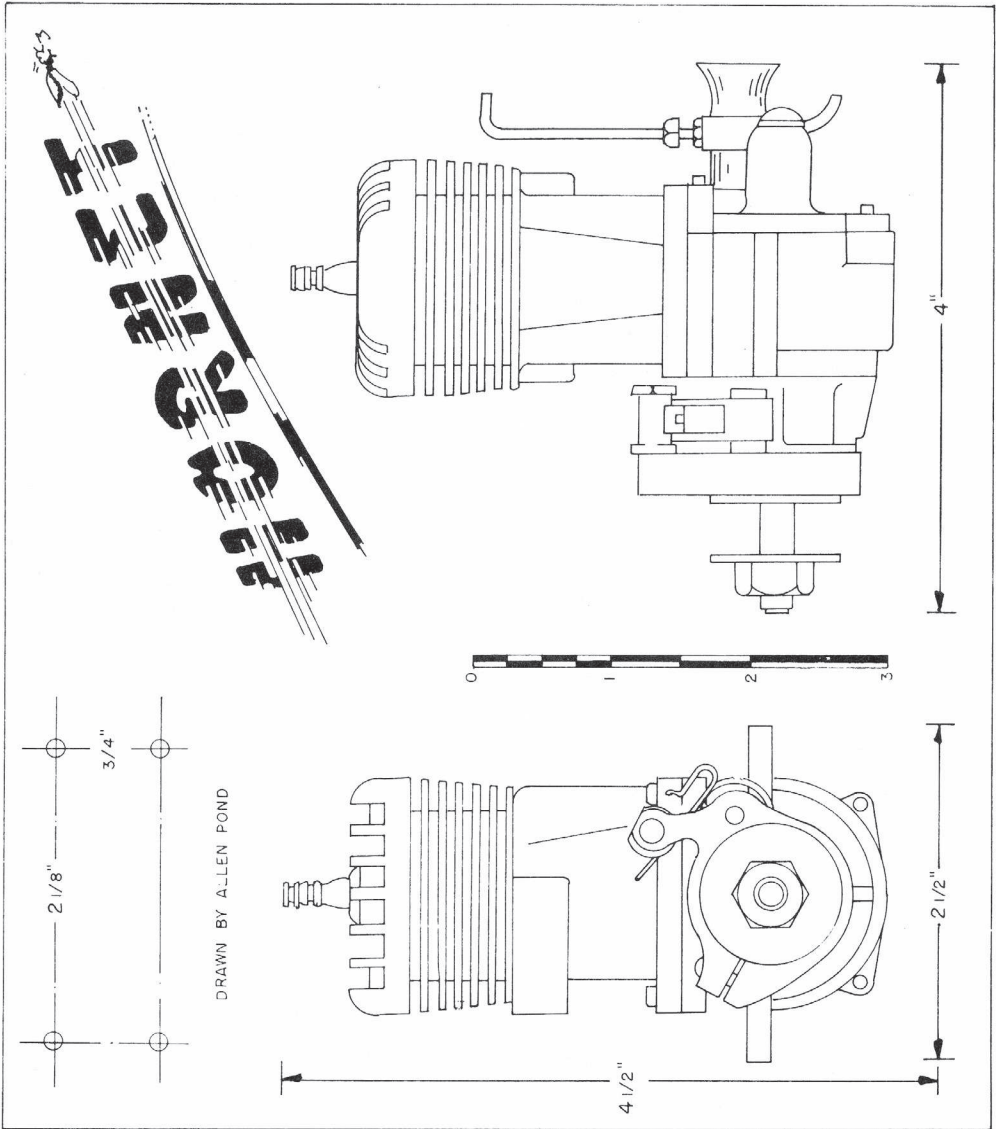

ENGINE OF THE MONTH

In the late thirties, interest developed in model race cars to the extent that quite a few rail car motordrones were built in California. Naturally, the race cars were powered by Dennyrite and Super Cyclone motors. Quite a few modification kits (the Berg being the most notable for the Dennyrite) were put out to help coax a few more rpm out of the motors.

About this time in Fresno, a city located in central California in the San Joaquin Valley, two race car engine enthusiasts, Walt Cave and Ray Snow, put their heads together to produce a first-rate racing engine.

Developed for their own use to start with, the Hornet motor became an overnight sensation with a series of eight consecutive wins! In no time flat, the partnership was simply snowed with orders. It was then that the Hornet motor went into production.

The boys were so confident of the performance of their motor that they came out with the flat statement that if the engine being sold did not do at least 70 mph in the test runs, that engine was not sold. Snow claimed the high quality machine work was responsible for the Hornet reputation of "no lemons."

Snow also produced an aircraft version that scared the majority of fliers, as they had never seen such power available. One of the big problems was the weight of 16 ounces, in many cases almost double that of the existing free flight engines available to the modeler. To put it frankly, most of us in those days didn't know how to handle that much power!

Then too, the price of the Hornet was not cheap, being priced at \$35 with flywheel. In those days, terms were a \$5 deposit and then wait until the plant at 3912 Kerckhoff St., Fresno, California, could produce the engine for you.

What made the Hornet so good? The first point of manufacture was in the heavily-built crankcase and cylinder head. These engines did not come apart under stress. Made primarily of aluminum castings (cylinder, piston, rod, and crankcase), about the only things that were hardened ground steel were the crankshaft, rings, and wrist pin.

With a bore of 15/16 in. and stroke of 7/8 in., giving a displacement of .604 cu. in., the Hornet was one of the first "square" engines. Compression ratio was 9.5, which gave a rather modest claim of 3/4 hp at 15,500 rpm. (Later engines such as the McCoy claimed 1-1/2 hp.)

With such a good engine, what caused it to go out of production? Actually, Ray Snow let the other manufacturers literally steal the market right out from under his nose. When Dick McCoy came out with his successful .60 engine (somewhat resembling a Hornet), the Duromatic Co. immediately launched on a high-powered advertising campaign with promises of immediate delivery to the dealers at a 40% discount, rather than the 33% discount offer by Ray Snow.

The Duromatic Co. made sure they had the control line speed engine market sewed up but good, by coming out with engine sizes for each class: A, .19; B, .29; Class C, .49; and of course the .60 for Class D.

With the distributors and hobby dealers now pushing McCoy engines for a better profit and almost immediate availability, it wasn't long before the Hornet Co. folded its doors and ceased mass commercial production. You have to be able to sell what you are making!

Arguments to this day still wage around the race car and model plane circles as to which motor was actually the best. A good Hornet fan will never admit a McCoy will outperform his motor. However, that's what makes horse racing, a difference of opinion!

Koppers

DRAWN BY ALLEN POND

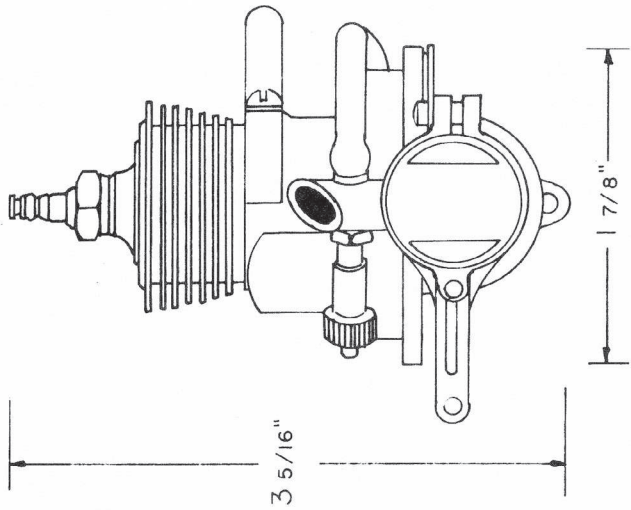
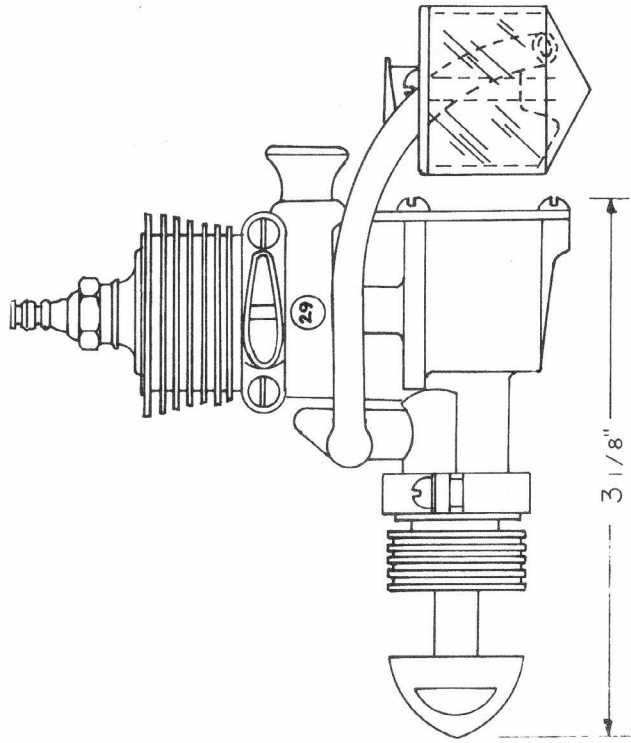
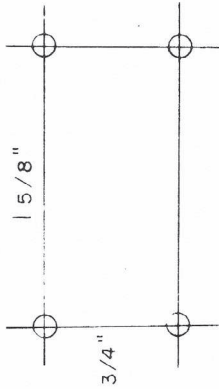

ENGINE OF THE MONTH

The year 1940 found Clifford William Rogers leaving the Syncro Devices organization to make his own brand of cheap engines, which eventually had the name of "slag engines" appended on them. Rogers put out a motor known as the Rogers KD-29 (KD = Knockdown), which was practically the same as the Syncro B-30 and Syncro PC-2. Bob Reuter, in an article on slag engines, noted that the patent drawings for the KD-29 were of the B-30/PC-2 combo. What the heck, when you have a winner, why yell "whoa" in the middle of a horse race!

The price of the Rogers KD-29 was extremely attractive at \$4.95. At this price you had to mail order the engine from Rogers himself. As far as can be ascertained, the motors were actually produced by the Judson Co. of Philadelphia. (Now you know where the Judco engine came from.)

Rogers got a terrific break from the Hobby Industry Association when they came out with their Air Youth program, aimed specifically at young people. Rogers promptly had his motor approved for the younger set, added a coil and condenser to the knockdown kit, and priced it at \$6.95. Without exaggeration, he must have sold a million of them, as every kid on the block had one!

In this same year, Rogers came out with an assembled engine in response to the requests of those who had very little mechanical ability. This engine featured a front rotary valve but still had the rear intake upon which the tank was hung. Why throw away all those thousands of castings because of a "new" design?

The engine we are featuring is the postwar version known as the Rogers 29/35 (another "new" design). The engine still had the same crankcase, shaft, and timer. About the only real change was a new, more deeply finned cylinder and a stub outlet where the original intake was previously.

The Rogers .29 featured a bore of 13/16 in. and stroke of 9/16 in. giving a displacement of .292. Almost all the parts were claimed to be made of an aluminum alloy. This so-called "V-alloy" had a high zinc content which wore very quickly when used in cylinder and piston combinations. The timer was the same as the prewar model, being a commutator brush or wipe-type employing a fiber insulator to keep the points from making continuous contact. Actually, this system gave a constant and even pressure on the point mechanism without resorting to the usual spring or cam type of contact. One thing for sure, you didn't have to adjust the points under this system!

The *Air Trails* test team, under the direction of Walt Schroder (this guy gets into everything!) and Louis Garami, found the strobatic tests of the Rogers .29 turned a standard 10x4 at 8,200 rpm, while higher pitch 10-inch propellers only turned 6,300 rpm. A high pitch 9-inch propeller was tried and gave 7,000 rpm. Walt noted the engine was extremely consistent at all stages with all sizes of propellers.

In summary, the author realizes that in order to keep costs to a minimum, the use of aluminum alloys was dictated. It truly was a shame that some parts (such as the piston, cylinder, etc) weren't made of steel. The Rogers would have been a nice running sport engine.

Interest in "slag" type engines (Syncro, Rogers, Judco, Genie, Buzz, et al) has recently arisen due to the efforts of Mark Fechner, of Salt Lake City, who has single-handedly championed their cause and sponsored a "Slag" event at the SAM Championships. If you want a lesson in futility and frustration, not to mention humility, try your engine starting prowess on a slag engine!

DRONE DIESEL

BY ALLEN POND



SCALE

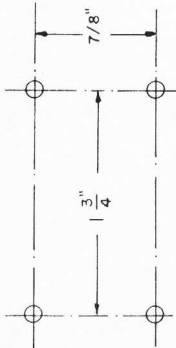

MOUNT LAYOUT

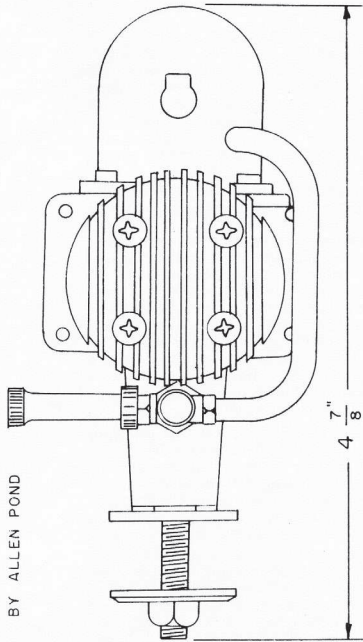

4 ⁷/₈

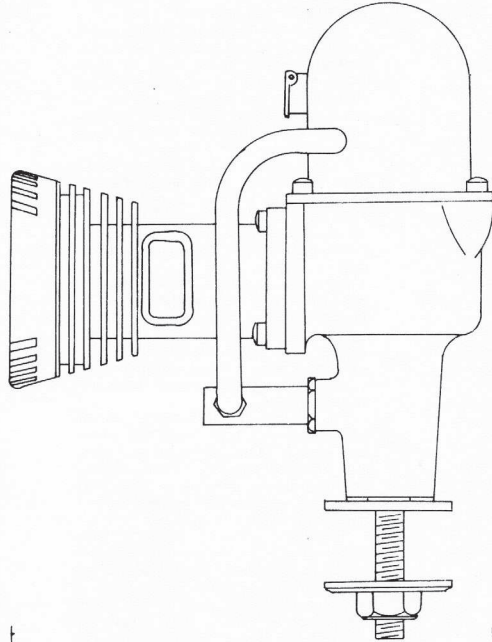

3 ³/₄

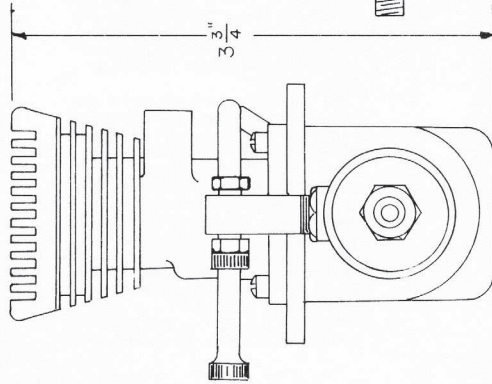

ENGINE OF THE MONTH

A lot of O.T. modelers are not aware that Leon Shulman got into the engine manufacturing game back in 1946. Known primarily for his out-of-the-rut designs such as the Wedgy, Zomby, and Banshee, Lee's postwar free flight designs of the Zoomer, etc. failed to catch on like his pre-WW-II designs.

Having gotten out of the Air Force, Shulman (between jobs) hit on the idea of producing a motor. It was the late 1945/early 1946 era where all that pent-up money earned during the war was just crying for a motor . . . any type of motor that would run.

The new engine by Shulman was first announced in the January issue of *Model Airplane News* just in time to catch the Christmas trade. The new engine was new in comparison to the others; it was a fixed compression, compression ignition motor, popularly called a diesel.

The Drone Diesel featured an all-black case with gold head. Of course, the engine came packaged in a black box with gold lettering. Priced at \$21.50, the engine was claimed to have been designed, engineered, tested, and approved by Leon Shulman (whew!).

Manufactured at 125 Broad St., Elizabeth, New Jersey, the new engine was an immediate success. The biggest selling point, of course, was the elimination of the pesky ignition system. By the March 1947 issue of *M.A.N.*, their slogan was "out of the carton, ready to run." This was no idle claim, as it turned out to be a bonanza in the control line game which was enjoying unprecedented popularity during this time.

The operating instructions for the Drone B indicate that a fuel mixture of three parts ether to one part of mineral oil was the desired combination. For warm weather operation, the firm recommended adding five drops of SAE 70 oil to the mix. The author, with his Drone Diesel, found that the standard diesel mix (1/3 ether, 1/3 kerosene, 1/3 castor oil) worked excellently. Of course, there always were those tinkerers who would add either amyl nitrate or amyl nitrite in small quantities.

The main drawback to the Drone was its fixed head, which did not allow for

weather changes, both in temperature and humidity. Using a mechanical starter (most of us used converted hand-turned aircraft starters) worked fine, but there was no thrust washer on the shaft that kept the crankpin from rubbing on the backplate when starter pressure was applied. Eventually the Drone people came out with a variable head and roller bearing shaft, but by that time the glow engine had come into its own and dominated the field.

Drone engines were produced from aluminum, with the crankcase, backplate cover (a punched plate), and cylinder made of aluminum alloy. The steel crankshaft, of rotary valve type, featured a squared intake for improved performance. Cylinder liner was of steel with a cast iron piston, both ground to a smooth finish. The piston employed a unique baffle design which was also claimed to produce more power.

The head was a flat-top multiple finned arrangement with gold anodizing, making for the distinctive appearance of the Drone. Connecting rod was also aluminum with bronze bushings. A full-floating steel wrist pin with brass pads rounded out the finish.

The *Air Trails* engine review gave the Drone a good write-up by stating the engine started easily and consistently. Strobatac tests gave results of 4,850 rpm with a 14x6 prop, 5,500 rpm with a 12x8 Hi-Thrust, and 5,290 rpm with a Testors 10x10 propeller. Frankly, the writer had the best luck in using a 13x6 Ritz propeller which seemed to give the best performance.

Drone diesel engines had a bore of 21/32 in. and a stroke of 7/8 in., giving a displacement of .297 cu. in. The compression ratio was fixed at 18 to 1. Surprisingly for a diesel, the engine only weighed 9-1/2 ounces. In summary, the Drone was a good engine for its time but became outclassed by the Torpedo, Orwick, and other hot Class B glow engines.



DRAWN BY ALLEN POND

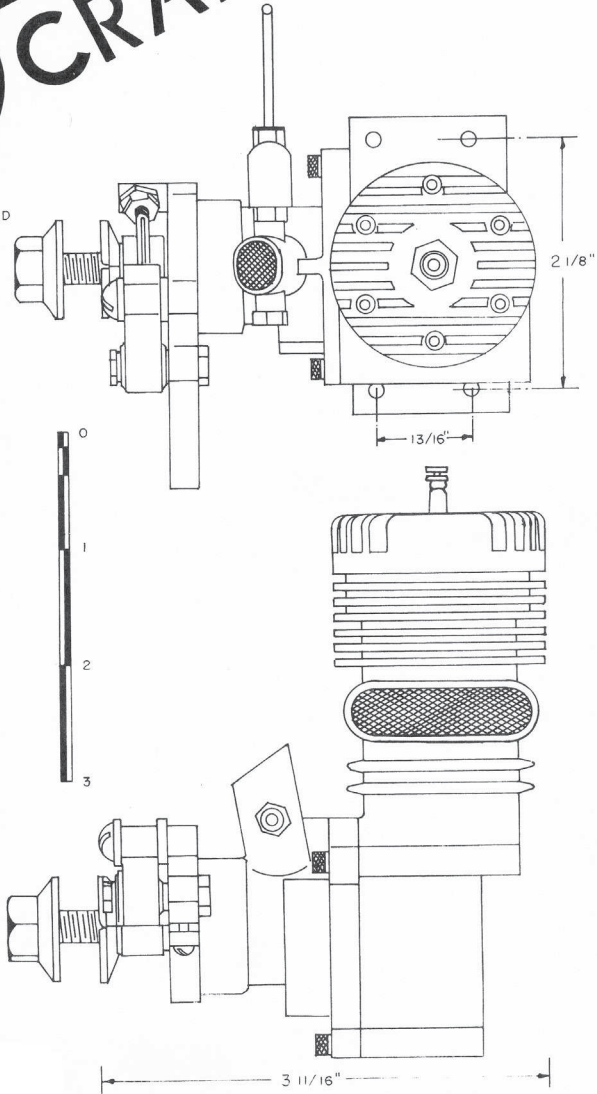

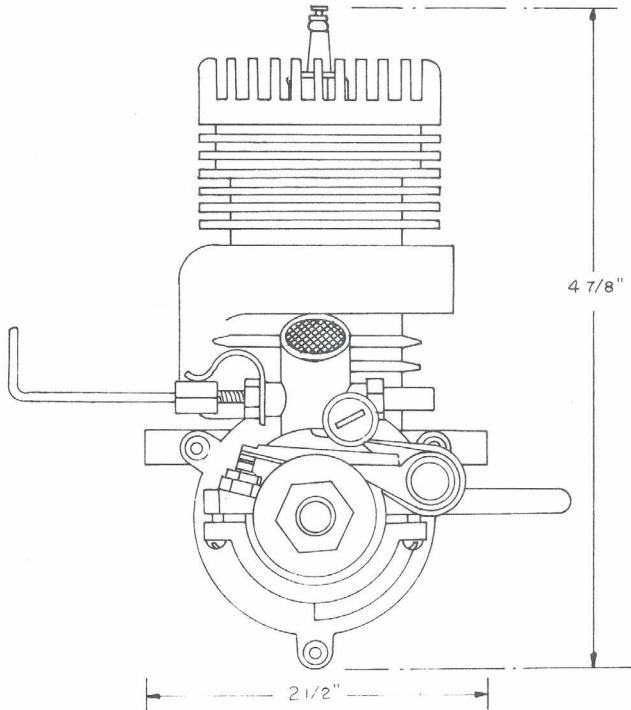

ENGINE OF THE MONTH

In the August 1945 issue of *Model Airplane News*, a new engine appeared in the advertisements. This engine, the Ken .61, was aimed directly at the tremendous popularity of control line modeling.

The Kencraft Co., located at 225 N. Seventh St., Garden Grove, California, featured this new racing engine at \$32.50 less coil and condenser. Weight was given at 17.5 ounces but later charts indicate the motor weighed 15.5 ounces.

Ken engines, when they first appeared in Southern California, were first tried in control line speed models. Even with their boasted "turbo valve," the performance was somewhat disappointing. The factory brochure indicated the turbo valve, although rarely needing adjustment, should be looked at if performance was not up to par.

Model Craftsman magazine ran a series of tests on all engines and found the Ken turned, on ignition, 5,650 rpm with a 14x8 propeller, 7,900 on a 14x6 prop, 7,000 on a 13x8, and 9,700 on a 9x10 prop. When compared to the contemporary speed king of the day, Ray Snow's "Hornet," the Ken motor suffered by comparison, as the Hornet turned 13,650 rpm on a 9x10 prop.

All tests, of course, were run on standard 3:1 mixes; hence, like in the case of the Forster .29, the Ken probably ran better on methanol. Actually, the performance obtained was quite creditable on ignition, but the engine was rather large and bulky. Worst of all, its overall performance did not compensate for the weight. Although a good engine in its day, it was simply out-classed by the Hornet and later the McCoy, in the speed circles.

The Ken engine featured an "over-square" ratio of bore/stroke, with the bore of .937 and stroke of .875. *Model Airplane News* rated the motor at .60 horsepower at 14,000 rpm (using a flywheel). The *Model Craftsman* people reported 13,700 rpm utilizing a seven-ounce flywheel. Compare this with the Hornet at 14,750 rpm . . . better than a 1,000 rpm difference!

Although the Ken engine did lend itself to "hopping up," the competition for the motor market was just too rough and another engine passed into oblivion.

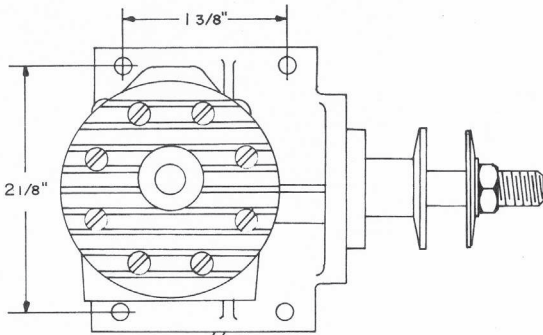

Bungay 600

DRAWN BY ALLEN POND

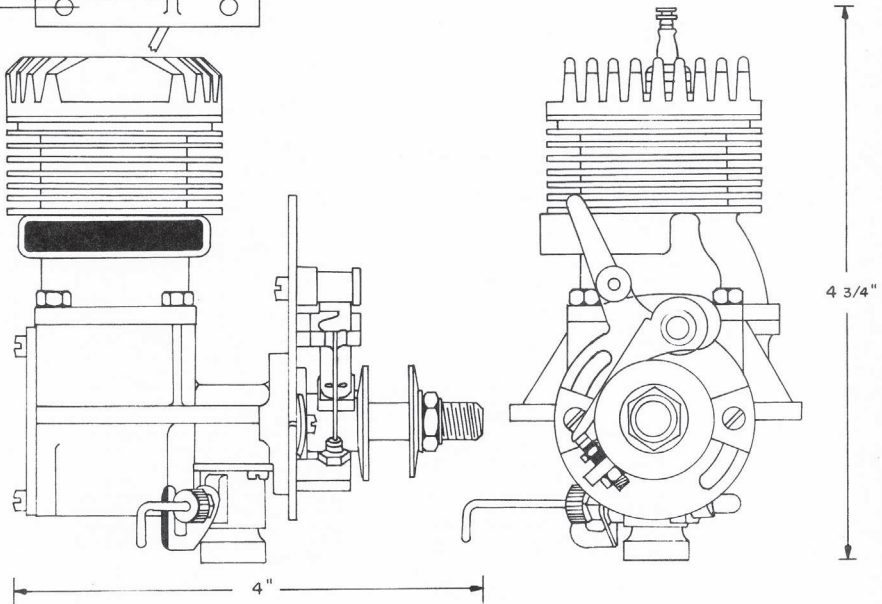

ENGINE OF THE MONTH

Every so often, an excellent product will come out only to fail because of the bad timing of the market demand. Such was the case of the Bungay "600," this month's engine of the month.

The Bungay 600, produced by the Bungay Brothers, located at 323 East 30th St., New York City, NY, was based on extensive research pointed at developing the best racing engine for high output. Advertisement appearing in the last four months of 1948 in *Model Airplane News* made the claim the Bungay developed over 40% more power between 18,000 and 19,000 rpm than any other engine in its class. This was backed up with a money-back guarantee!

Ed Ingram, in an article in *Model Airplane News* describing the Bungay motor, stated he observed an aluminum 8-inch dia., 6-inch pitch propeller being driven at 19,400 rpm. Tests with flywheel showed results of 28,000 rpm. Best part of all was that the fuel employed was a straight methanol-castor mixture. One often wonders what performance would have been obtained using heavily nitrated fuels.

The Bungay engine was different from the regular run of high speed motors such as the Hornet, McCoy, etc., which employed rear rotor induction disks. The Bungay, on the other hand, employed the old reliable rotary shaft induction with an updraft carburetor. To eliminate the end play so prevalent in this type crankshaft induction, the Bungay people provided a steel disk cast in the end of the aluminum alloy crankcase.

The size of the updraft venturi diameter was one that led to considerable experimentation. Like all tests of those days, the diameter was determined by "cut and try" methods. The Bungay Brothers found that too small a venturi opening severely restricted engine performance, while a large opening made for hard starting and critical needle valve settings. Of course, in those days, pressurization of the tanks was not considered (or even used!). This would have eliminated the problem of fuel draw with a large venturi opening.

One notable fact that many modelers overlook in running their old time motors is the use of 4-1/2 volts rather than the prescribed three-volt input. Many old timers have found the added voltage makes engines much easier to start, run better at high speeds, dwell time on the points can be increased and point clearance setting reduced to as little as .004 inch. Now that's close!

The compression ratio is another favorite topic of modelers who like to "hop-up" their motors. Increasing the compression will, in some cases, increase performance. Again, there is a diminishing return of gain as compression is increased. So it was with the Bungay people as they went as high as 18 to 1 in compression ratio, only to find they had to settle on an optimum ratio of 9.80 for general all purpose racing.

For the technically minded, the Bungay motor featured a bore of .940 and a stroke of .875 inches, giving a displacement of .607 cu. in. Piston rings and cylinder liner were steel fitted with aluminum piston and drop forged 14ST aluminum connecting rod. The cylinder head and crankcase were cast aluminum alloy using a claimed special casting method to eliminate pin holes and rough finish. Weight of the engine was 16-1/2 ounces without coil, condenser, and battery (practically the same weight as all hot 60 engines of that period).

The arrival of the Bungay engine on the market, when it was finally released after much experimentation, coincided with the arrival of the new Dooling .61 engine.

The Dooling Brothers were no newcomers to the speed circles, so a decided advantage went to their product. Then, too, most all the hot engines were being produced on the West Coast: Hornet, McCoy, Hassad, Cave, Atwood, to mention a few. The only other engines, the Howler and Ball, were being produced in the Midwest. Here was a newcomer in the East Coast, struggling for recognition in a field of already plentiful, well recognized, red hot engines.

Only a few Bungay engines were actually sold and unfortunately, the top names in racing did not use this new engine. As usual, in the modeling circle, if a certain engine or kit does well, there is an implied guarantee that you, the purchaser, will have the same luck and possibly win. So it was with the Bungay engine. With no national records to claim, no big contest wins, and no outstanding big name in speed utilizing the engine, it was a foregone conclusion that the engine simply could not succeed no matter how good it was. Another well made engine joined the ranks of model oblivion.

Air-O-Z
DIESEL

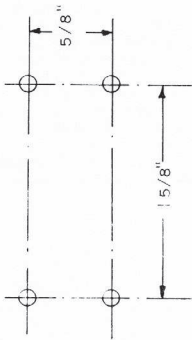

DRAWN BY ALLEN, POND

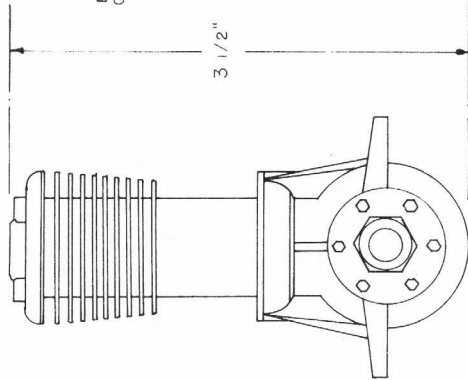
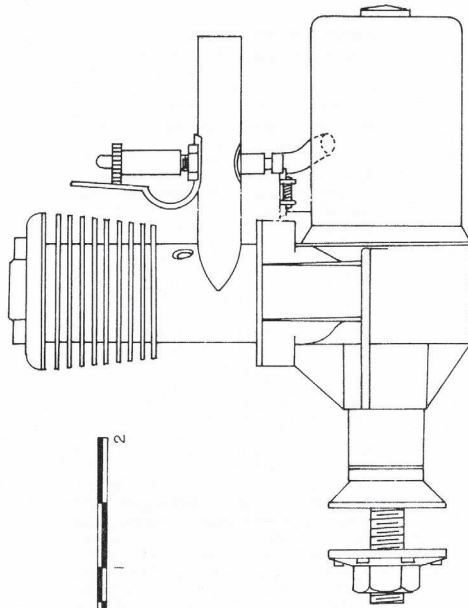
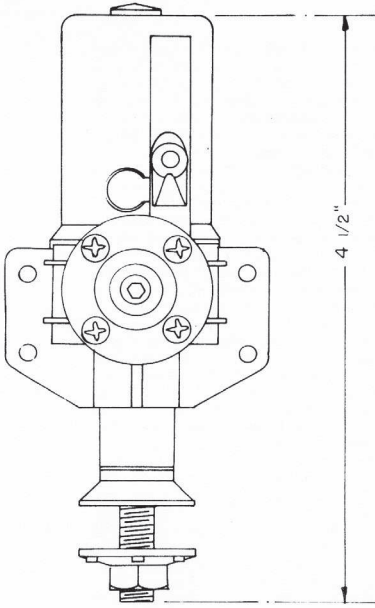

ENGINE OF THE MONTH

In the February 1981 issue, we ran the Drone Diesel as the featured Engine of the Month. No question about it, Leon Shulman did much to popularize the use of diesel engines over the then prevalent ignition engines.

Shulman did so well with his Drone diesel in controline, winning the N.Y. Mirror meet and later on, the 1947 Nationals, that it wasn't long before similar type diesels would make their appearance. Among those were the Deezil, Mite, Vivell, Edco, Micro, and this month's engine, the Air-O.

Always with a sharp eye to the trend of model competition, Ray Acord (who has bought up the Bunch engine stock) decided to enter the diesel motor market. This was done with such little fanfare, the motor went almost unnoticed, until a picture showed up in the Air-O advertisement in April 1948, *Model Airplane News*. Up to that time, Gotham Models had been listing it in their available engines.

To quickly get into the market, Acord used the existing crankcase and shaft from his Mighty Midget G-P (glow plug) engine and put on a small bore cylinder, reducing the total displacement to .278 (Quite a drop from .45!) The motor features no by-pass on the outside, being a three-port engine. To save further money, the head was fitted with a screw (to operate the contra-piston) that would accept an Allen-type wrench. This was the adjustable head setup. Acord felt once you had the ideal compressions setup for the day's flying, no further changes would be required. Of course, there was always the claim of the advantage over a fixed compression head, a feature of the Drone engine.

Surprisingly, the manufacturer also claimed the use of diesel engines in model race cars yielded speeds of 50 mph plus in Thimble-drome cars. Small race cars were the new fad at that time, in Southern California, and Ray was looking at that angle also.

The new diesel was rated at 1/5 hp at 6500 rpm. The Air-O people also claimed the engine could be made to develop

1/4 hp at 16,500 rpm. The latter rating was made using direct drive in race cars.

Those interested in the technical aspects of the engine, will find the .278 cu. in. displacement yielded a bore of .687 and stroke of .750 inches. Weight was 7-1/4 ounces; not a bad weight for a Class B diesel type engine that includes a metal tank. The cylinder and cooling fins were machined from steel bar stock. The piston and contra-piston were made of heat treated alloy steel, centerless ground and lapped to the cylinder. The connecting rod was chrome molybdenum with no bushings. The crankcase was fitted with bronze bearings for the crankshaft.

The crankcase, taken from the Bunch Tiger Air-O, was produced from aluminum alloy die castings. Of interest is the crankcase casting for the diesel engine that still has the place for timer used on the Tiger. No question about where that crankcase came from!

Everyone has his own pet diesel fuel. The Air-O people recommended using a mixture of seven parts ether, six parts castor oil, and four parts kerosene. Compare this concoction with that recommended for the "Speed Demon Diesel"; 4 parts SAE 30 oil, 4 parts ether, and 2 parts distilled wood turpentine.

Probably the best running fuel this writer has run into is the fuel recommended by Jack Bayha, who experimented with diesel engines and fuels at quite some length: 20% SAE 20 motor oil, 20% ether (diethylene glycol monobutyl type), 20% ether (ethyl oxide, good old sleep inducer), and 40% diesel truck fuel. Add to this 2% amyl nitrate and you have a real hot diesel fuel.

The writer in his experimentations during the late forties, found that 20% castor oil, 40% light grade diesel fuel, and 40% ether (preferably high grade) worked the best. Use of amyl nitrate (which works better than amyl nitrite, having one more oxygen molecule) is to be used quite cautiously. Any more than 2% and detonations will actually shear the crankpin on the shaft. In any respect, in running diesel engines, you will always end up smelling like a hospital ward!

THERMITE 60

DRAWN BY ALLEN POND

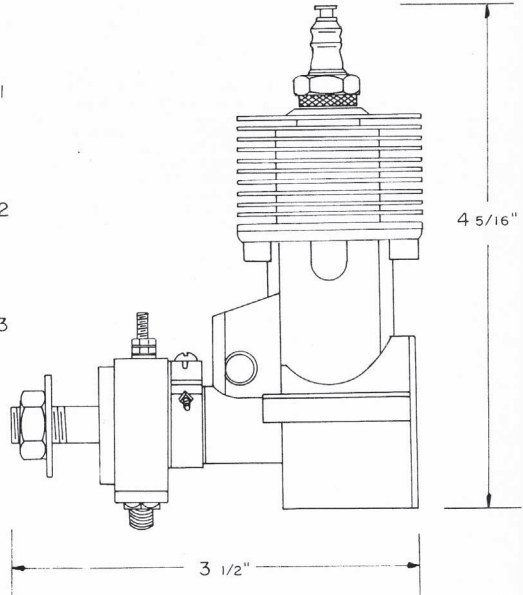
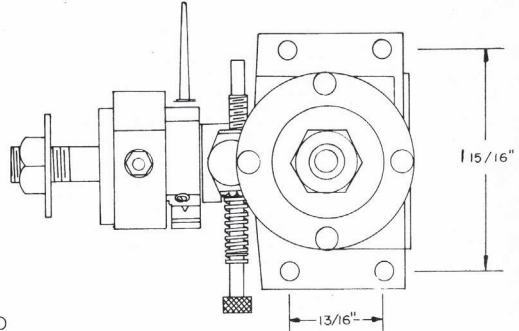
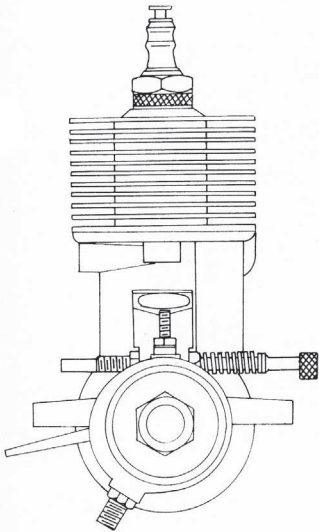

ENGINE OF THE MONTH

Every so often, this columnist likes to feature a rare engine that the average now-a-day modeler knows little or nothing about. A comment is in order here. All rare engines as featured are taken directly from an actual example. The columnist is indebted to Karl Carlson for the use of this month's motor. Matter of fact, Jim Brown, manufacturer, turned out several versions and we have picked out the Thermite 60, that best represents the 60 series. Most variations appear to be in the timer drive washer size.

As reported earlier in the article on the Little Dynamite, the first production engine produced by Jim Brown, the manufacturing facilities consisted of a backyard shed and garage type set-up with a lathe, drill press, etc., to form a simple machine shop. However, this is not intended to detract from Jim Brown, as he proved to be an excellent machinist and engine man. Engines were designed in collaboration with Dick Schumacher and Charlie Pottol, who represented the modeling fraternity's needs and trends.

Actually, after the distribution rights to the Little Dynamite were assigned to Offenbach Hobby Supply Co., of 489 Hayes St., San Francisco, California, Jim found himself in the peculiar position that he could no longer retail the engine over the counter. This led to the development of a motor series known as Thermite which were little more than a downdraft carburetor version of the Little Dynamite.

The small Class C Thermite was basically the same size as the Little Dynamite. Shortly thereafter, Jim began experimenting with larger size engines in response to the demands of modelers for such an item. The success of the Super Cyclone and the Ohlsson 60 did much to influence this thinking.

A series of 60 engines was produced but never in any great quantity, as Brown preferred to cater directly to the modelers after the Little Dynamite experience. With only word-of-mouth among modelers as his form of advertising, this naturally led to a small demand, and a corresponding small output of Thermite 60 engines.

Unfortunately, the writer has no performance figures to report, as one simply does not run old collector type motors. The value is such that if the motor is damaged, there is simply no way of repairing same unless one has a source for casting and machining new parts. Then too, with Jim Brown's death in the early '50s, there seems to be no record of what happened to all the dies, forming tools, etc. Truly a shame, as reports had the engine highly rated in the early '40s.

The Thermite 60 utilized all the proven construction features of the Little Dynamite, particularly the enclosed timer which worked excellently. As pointed out before, one had to be quite careful in removing the drive cam, as there were no less than four to eight different ways to reset the timing cam.

Thermite engines were made of a one-piece aluminum alloy crankcase with a backplate screwed to the rear of the crankcase. The cylinder fins were machined from steel with a hardened cylinder liner. The whole assembly was bolted to the lower case with four machine screws. Actually, a very simple assembly set-up.

Jim believed in adequate crankshaft support, as he featured Johnson bronze bearings carefully fitted to eliminate oil leaks and end play. Needle valve was the same as all previous motors produced by Brown. All in all, the Thermite 60 was a typical Jim Brown engine, a minimum amount of parts, well made, carefully assembled, and in general, a more than satisfactory engine.

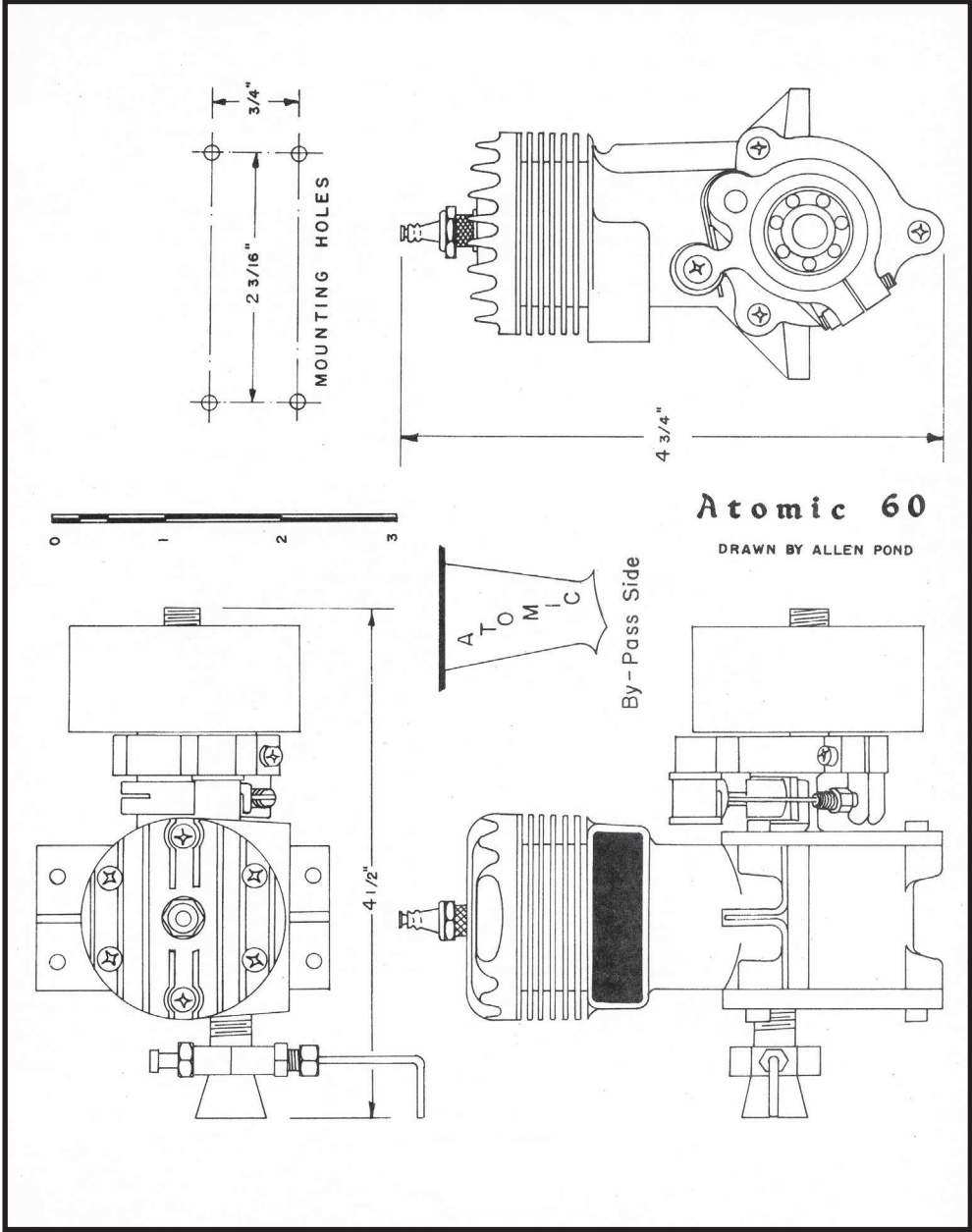

ENGINE OF THE MONTH

In line with our policy of introducing rare or little-known engines we are indebted to that well known engine collector and manufacturer, Karl Carlson, for the use of this month's engine, the Atomic 60.

When one first sees this motor, one is immediately struck with the similarity to a Hornet or McCoy engine, particularly the latter. Despite protestations to the contrary, this writer still feels the root of all good racing engines was the Hornet, as developed by Ray Snow and Walt Cave.

The Atomic, as it was called, was the brainchild of William P. Cubitt, San Francisco Bay Area Marine Operating Engineer. It might also be of interest to note the Talisman motor, now being offered by Replica Engines, was also a design by Cubitt.

According to Carlson, the initial output was to be 100 engines, with 1000 castings made up for future orders. This writer ran into the castings in a San Francisco foundry shop unclaimed (and unpaid for). At the time of this discovery, the foundry was busy reclaiming the aluminum alloy by remelting the existing castings. The author was able to salvage enough castings to make three engines, but alas, lacked the necessary lathe and sundry machining tools to complete the motors. Eventually the castings were given away to some forgotten modeler.

Bill Cubitt's background indicated he was no slouch at motor design, as he participated heavily in rail track and tether cable race cars during the forties. Of course, during World War II, most of this activity declined as there simply were not enough engines and parts for the average modeler to maintain a good backlog of repair items.

Carlson relates that John Gracie, a noted collector in his own right, made many attempts to contact Cubitt during WWII, but was unable to locate him. Carlson, when put on the track of Cubitt, simply did what every good detective does first; look in the telephone book of the surrounding area of suburbs. Sure enough, there was Cubitt's name listed not more than a mile distant from Carl's home at that time!

The Atomic engine had several features worth mentioning, the most notable being the by-pass idea which was taken from Evinrude outboard motors. This, of course, was one of the trademarks of the later McCoys. Another interesting feature was the elongated slots in the rear back plate to allow small angular adjustments of the rotor valve. This was for those modelers who were looking for every little bit of rpm they could obtain from minute adjustments of their motor.

The Atomic was also one of the first racing engines that featured a hemispherical head with a domed combustion chamber, giving a displacement of .604 cu. in. (the top displacement allowed under race car rules). Hornet engine influence can be seen as the bore and stroke (.937 x .875) are identical, with a rated power of 3/4 hp. The Atomic, due to its one-piece crankcase, was slightly lighter at 13 ounces.

For the technically minded, the Atomic featured an integral sandcast aluminum cylinder and crankcase fitted with a Mehanite liner. The aluminum alloy piston was fitted with a bronze bearing for the wrist pin which in turn was fitted to a Dural 245T connecting rod. The sand cast aluminum alloy head was fastened with six screws. A hardened steel crankshaft was carried by ball bearings with a thrust bearing to prevent the shaft from rubbing on the case. Intake, of course, was the popular speed method of the day, the rotary disk type intake.

Horsepower ratings were arrived at on the basis of 16,000 rpm. However, the manufacturer claimed 18,000 rpm using a 10-inch, 12-inch prop. Unfortunately, the fuel employed was not specified.

In conclusion, the Atomic 60 appeared to be a well made engine, but unfortunately, offered no specific advantage over the hot-selling McCoys or the ever dependable Hornet. It was simply another case of a good engine being pushed off the market for lack of sales and capital.

VIKING TWIN 65

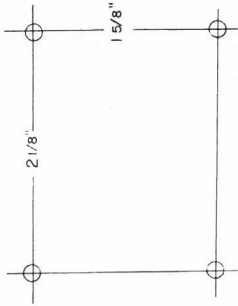

DRAWN BY ALLEN POND

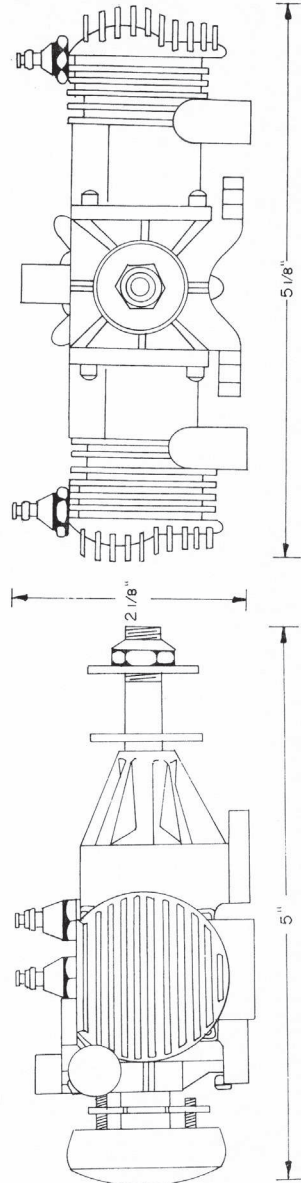
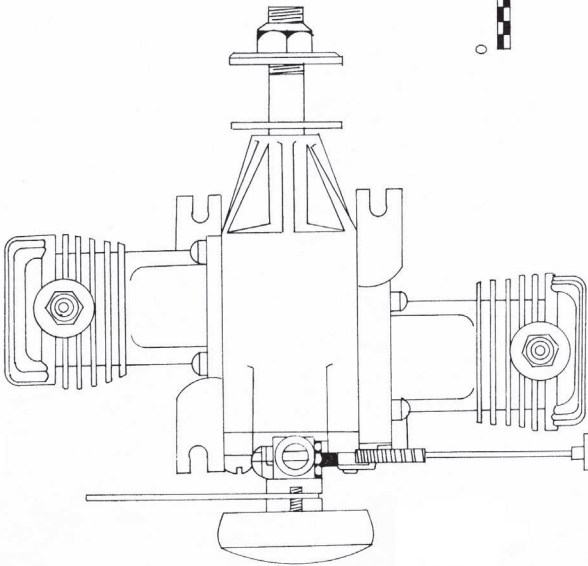

ENGINE OF THE MONTH

In the September 1946 issue of *Model Airplane News*, a full page color ad appeared announcing the arrival of the Viking 65, a new twin engine illustrated with red case and red three bladed variable pitch propeller.

Called in the early days "The Red Knight of the Sky," the selling price of the motor was \$24.75 with an additional \$2.35 for the fancy three bladed prop. The two items could be purchased on a package basis for \$26.50.

Built by the MacVal Mfg. Co., 3223 Burton Ave., Dept. 9MA, Burbank, CA, this motor was another attempt to produce a twin for the control line scale model, the craze presently sweeping the country in the late forties.

The Viking 65 was actually .647 cu.in. displacement brought about by a bore of .812 and stroke of .625. Weight of this twin was 11 ounces, quite light compared to the OK Twin at 22 ounces. Surprisingly, the competitive Scout Twin and Ace Twin engines weighed only 11 oz. and 9.5 oz. respectively showing quite some similarity in design construction.

The Viking engine featured die cast aluminum alloy cylinder head and crankcase. Crankshaft was machined from Chrome Moly steel with steel piston and liner. The timer case was plastic, located in the rear for ease of adjustment. Two ball bearings supported the crankshaft.

Performance figures are pretty meager on the Viking with only the manufacturer claiming 1/2 horsepower at 8,500 rpm. However, there is no indication these figures were obtained with the advertised three bladed propeller. As a matter of fact, the prop shown in the advertisements was a wooden model. According to reports received, the plastic three bladed propeller never went into mass production. Hobby dealer Art Swift (at that time) stated the propellers were completely unsuitable with the red plastic propeller blades separating under high rpm from the two piece die cast hub.

As for Viking engines, back in 1964, Dan Sitter had all the molds, patterns, dies, etc. to the engine. Where and who has the parts now is unknown to this columnist as he has not kept up with the engine collectors that closely. If we receive more information on the status of the engine, we will be sure to let you know.

BUNCH "WARRIOR"



DRAWN BY ALLEN POND

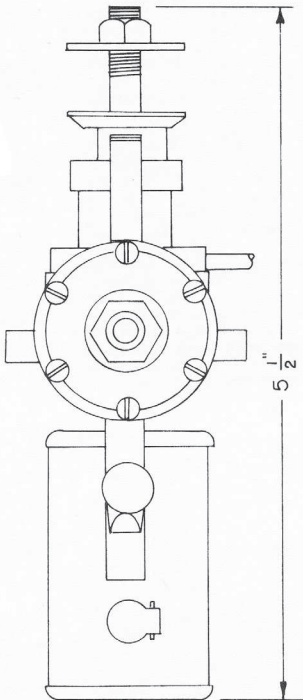

(3) 1/8" HOLES
1 13/16" B.C.

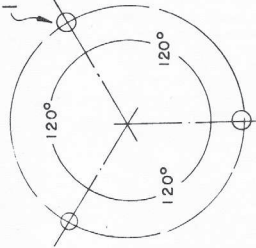

MOUNT LAYOUT

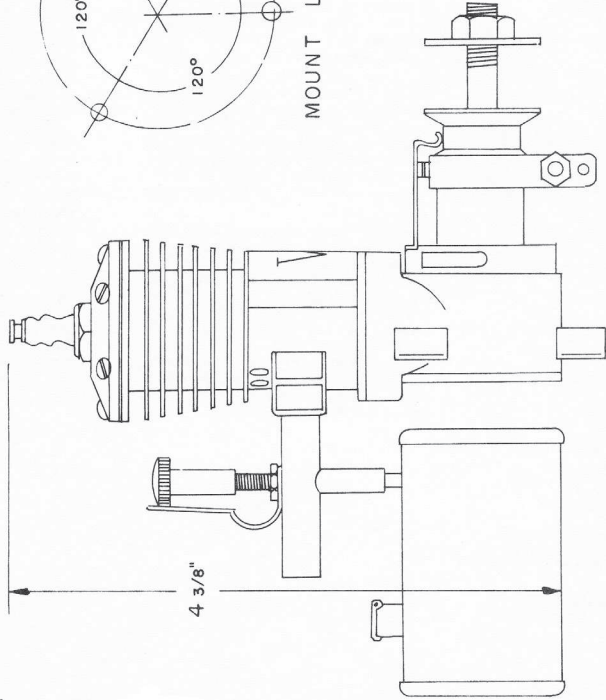
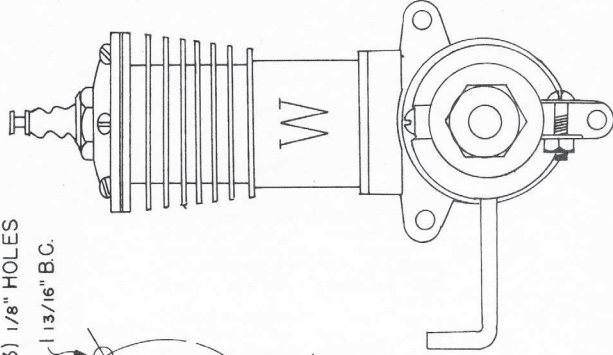

ENGINE OF THE MONTH

Of all the controversial motors produced by Bunch Motor Co., of 5011 So. Hoover St., (at that time) Los Angeles, CA, the "Warrior" takes the cake. Inasmuch as not too many of these engines were absorbed by the American market, these engines keep popping up in England. Evidently, when the motor failed to appeal to the U.S. modelers, the main production run was shipped abroad.

The "Warrior" first made its debut in the January 1938 *Model Airplane News* issue. Later advertisements carried the engine with the entire Bunch line (6 motors) showing the Mighty Midget upright @ \$9.85, the Mighty Midget inverted @ \$10.10, the Gwin Aero upright @ \$11.35, the Gwin Aero inverted @ \$11.60, the Mighty Marine @ \$11.40, and the Warrior at \$12.00, the highest of the series.

Some speculation by engine collectors have led to the assumption the Warrior was produced to compete with the Baby Cyclone, but actually the radial mount feature was incorporated in the Bunch line to compete with the Ohlsson Gold Seal, which was enjoying tremendous popularity with model plane designs especially designed for radial type engine mounts.

Among the new features of this Bunch engine were the adjustable spark advance with locking screw, and the provision for easy point adjustment. Other features advertised were the use of a steel cylinder (no cheap iron or die castings, as they claimed), aluminum piston with two steel rings, aluminum crankcase with three-bolt radial mounting, tempered steel spring with tungsten points, and a Champion spark plug (the best in this writer's opinion).

As reported in a previous column, the name of the "Warrior", according to Howard Broughton, then the Project Engineer of the firm, was derived from the automotive red paint they were using called Buick "Warrior Red". The engine, which owes its parentage to the Might Midget, was clearly stamped with a "W" on the bypass front.

With the tremendous competition for the motor market in Southern California, it didn't take long to sort out the shortcomings of this new engine. The main bearing was weak, and even worse, the straight and thin sleeve was unsupported (a la Baby Cyclone). With no bracket support, shafts could bend easily or the whole assembly could break off suddenly on impact (like a bad landing).

With this glaring weakness, it wasn't long before advertisements of the Warrior engine by the Bunch Co. were abruptly dropped (June 1938), barely six months after its initial inception. Truly a shame, as the adjustable locking feature of the timer was an excellent item.

For those interested in statistics, the Warrior featured a bore of 7/8 and a stroke of 13/16. Height of the engines was 4-1/2 inches, with an overall weight of 6-3/4 ounces, which included the metal tank. As reported previously, the engine sold for \$12.00, complete with coil and condenser, on a vertical wood mount. Powerwise, the motor was rated at 1/5 hp, turning 5500 rpm (propeller figures not given).

Many modelers complained about the engine being dropped, but the Bunch people were smart enough to realize the motor would do their reputation more harm than good in the long run.

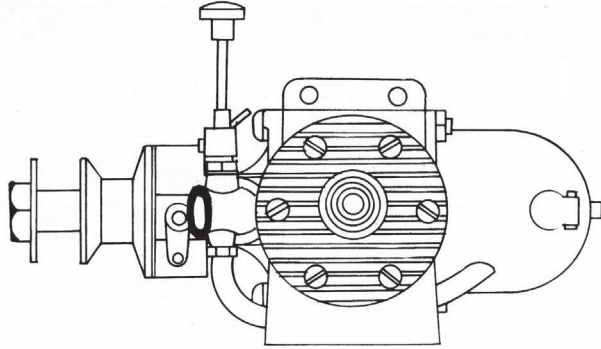

**ATWOOD
TRIUMPH
.49-.51**

DRAWN BY ALLEN POND

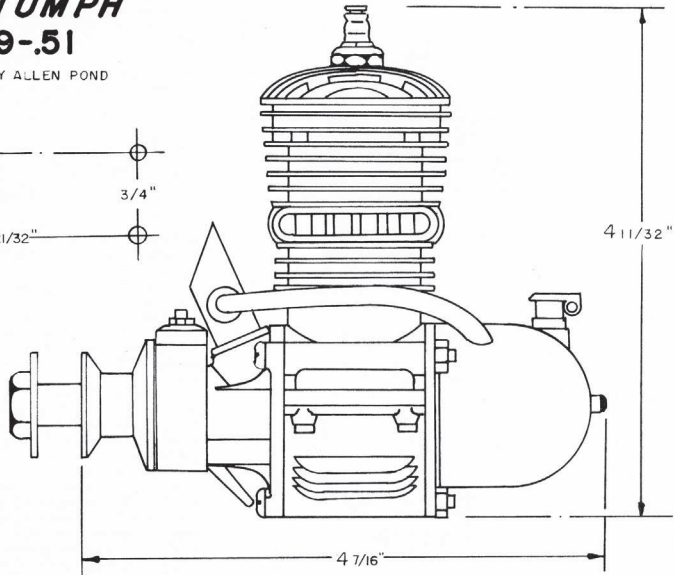
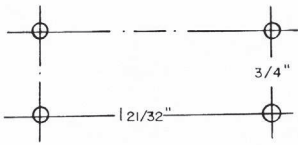

Engine of the Month

Of all the engines produced by that fantastic engine genius, William E. (Bill) Atwood, the Atwood Triumph probably stands out as an engineering "triumph" in die casting. Developed over a long series of engines, the Triumph represented the best to be had in die casting; crankcase casing, cylinder head, gas tank and forward section containing intake, crankshaft bearing, and timer housing.

The Triumph engines, in this case the "49" and "51", were first advertised in Model Airplane News, October issue of 1947. Coinciding this announcement was the advertisement from Micro-Bill Inc., extolling the virtues of the new Arden glow plug; an omen presaging the obsolescence of ignition engines. Matter of fact, the advertisement offered a choice of the 49 or 51 ignition engines at \$20.00 or the same duo on glow for \$18.00 less glow plug.

Actually the engine was created to compete in Class C (max .50 cu.in. displacement) and Class D (.51 cu.in.). This idea was to be employed again and again by Atwood and other manufacturers, notably K&B Mfg. Co.

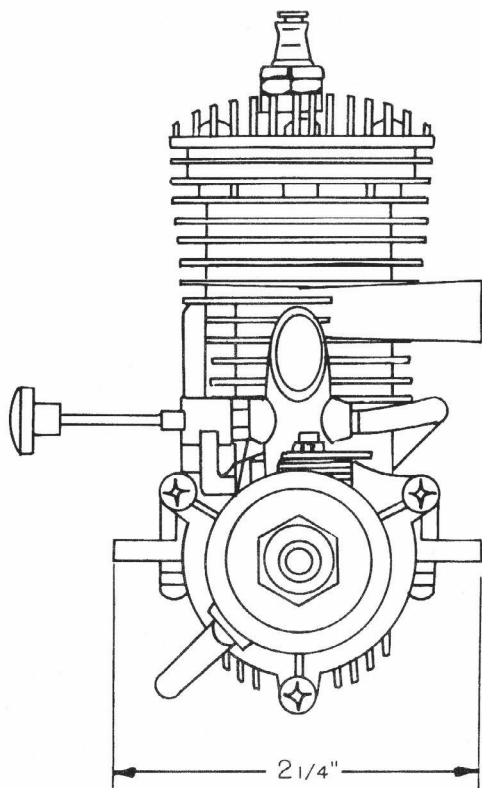

However, Atwood ran into tough luck with this engine as it did not prove out in the control line circles and worse yet, the free flight events were reorganized to accommodate the new 1/2A engines. This meant Bill had two engines in Class C (.301 to .65 cu.in. displacement).

Actually, the engine was quite good and featured several gimmicks to attract the prospective buyer's attention. The so-called Atwood "Repak" induction claimed to produce increased performance based on the new style air accumulation chamber. Of course, the Atwood "Justex" timer was the thing that was to simplify trouble shooting the gap of those pesky points. The idea was simple, loosen lock screw, rotate the hardened timer bearing to the adjustment required. Then tighten the lock screw. Actually, this was a variation on the old Orwick timer adjustment.

Another Atwood feature, not normally seen in other engines, was the aluminum alloy split crankcase. This lower section was screwed to the upper just inside of the mounting lugs. This allowed for quick inspection of the lower end of the engine.

On the technical end of things, the Atwood 49 and 51 engines both had the same stroke, .790, with different bores, .890 in. and .900 in. respectively. Weight was the same for both, 8-1/2 ounces. The compression ratio also same: 7-1/2 to 1.

This rotary valve type engine featured a solid alloy steel crankshaft, centerless ground and hardened. Crankpins were produced the same way. The connecting rod was bushed on each end and supplied with oil holes. The two-ring type piston was actually a permanent mold, 195 steel alloy, heat treated, and fitted to an alloy steel cylinder with full 180 degree porting. The engine was provided with mounting lugs to allow beam or radial type mounting.

Flying Models magazine ran some strobatac tests and found the best rpm was 15,000 using a 9 dia. 8 pitch Tornado prop. The testing team indicated the motor actually ran better than this as the measuring limit of the strobe was 15,000 rpm.

For the free flighters, a 12 in. dia. x 6 inch pitch Hi-Thrust propeller would turn 13,800 rpm using standard Red Devil glow plug fuel. A not too shabby performance!

Despite the advanced design and performance of the Triumph motors, their death knell was sounded when they were rule changed to have to compete with .60 engines. This was true of other engines such as the Madewell 49, Rocket 46, OK 49, and others that were designed to the top limit of the then Class C division.

MOLNAR 78

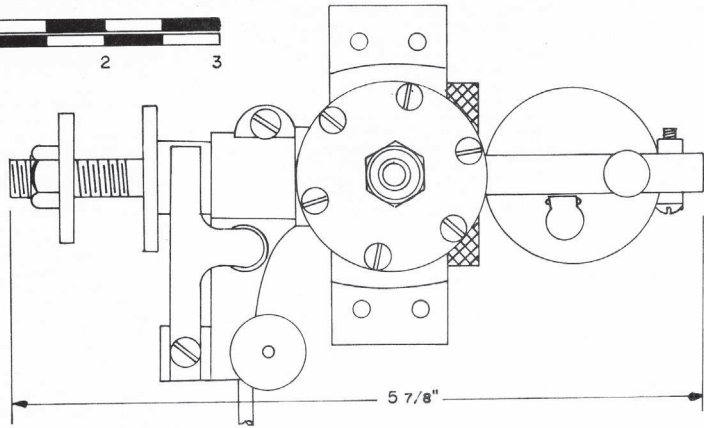
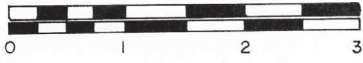

DRAWN BY ALLEN POND

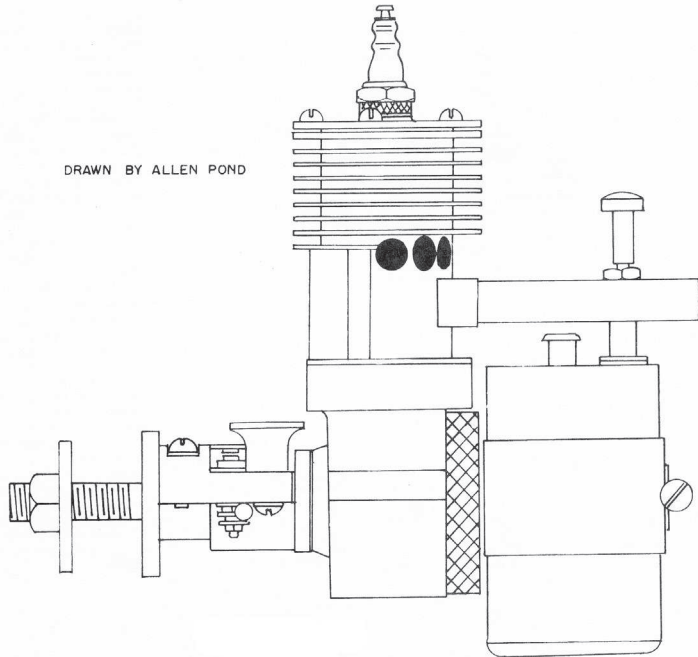

ENGINE OF THE MONTH

Some engines came on with a very large fanfare, with heavy advertising in hopes of boosting immediate sales. Other engines, like our engine of the month, the Molnar 78, appeared very unobtrusively with only one advertisement. After that, the Molnar people were content to allow the Polk Bros. to act as distributors.

In some respects, this did prolong the life of the motor, as Irwin Polk was able to find ways to publicize the motor at little or no expense. The publication, "The Model Airplane Annual, 1941-42", written by Graham and Cleveland, published by McBride, featured a photo

and three-view drawings of the Molnar 78. The book sold quite well and was responsible for many dealers stocking the unpublicized motor.

Designed and manufactured by the Molnar Model Motors Mfg. Co., 118-120 Albermarle St., Trenton, NJ, the Molnar 78, a reduced version of the Molnar 98, was aimed at the modeler who liked big models and also to the then budding would-be radio controllers looking for something else besides a Forster 99 to power their heavily loaded models.

As indicated in previous articles, all engines are drawn from actual examples. This month we are indebted to David Brodsky, 5542 Lauren Dr., San Jose, CA 95124, for the use of his fine specimen. At first glance, this Molnar appears to be rather crude, but on close inspection, the modeler finds the work has been put inside where performance depends on good fits.

The Molnar people advertised their ringless piston was made from solid Chrome Moly bar stock, heat treated, ground, and lapped within one ten-thousandth of an inch. Based on this fine fit, a claim was made for 12,000 rpm using 15 or 16-inch propellers. The engine came guaranteed to perform as advertised.

For the technically minded, the Molnar engines feature cylinders turned from solid chrome molybdenum. This material was also used for the head and piston, as noted above. Wrist pin was tool steel with two keys to prevent sliding and scoring of the cylinder walls.

High speed bronze was used for bearings in the connecting rod, held in place by a split washer. The crankcase, made of aluminum alloy, featured Oilite bearings pressed into place. A balanced crankshaft was machined from Chrome Moly, heat treated, and then fitted with a cam on the outer end of the tapered crankshaft to help promote good compression and vacuum in the crankcase. Aluminum alloy was used for most of the miscellaneous parts, such as the timer arm, air intake, etc.

The Molnar engine was square (one-inch bore and stroke) with a displacement of .7854 cu. in. Actual bare weight was 16 oz., with advertised flying weight of 18 oz. Strangely enough, no horsepower claims were made, but on the other hand it was stated the engine would handle nine-pound models easily.

Like so many of the post war engines, the Molnar was no exception and ended a victim of the new glow plug craze. Another interesting engine passed into limbo.

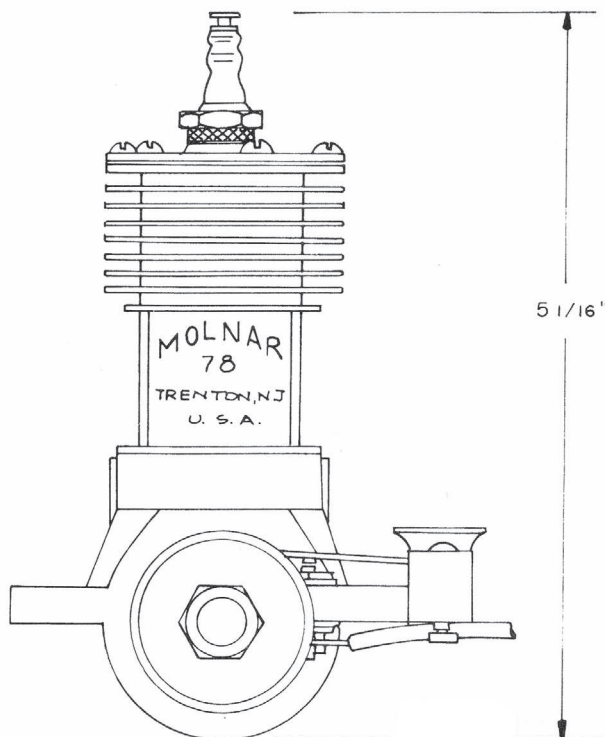
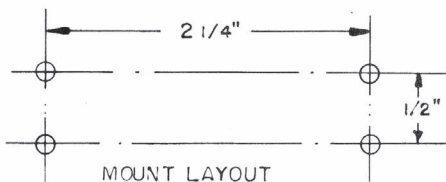

MICRO 19

DRAWN BY ALLEN POND

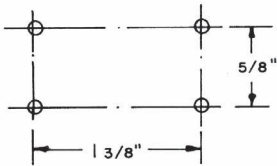

MOUNT LAYOUT

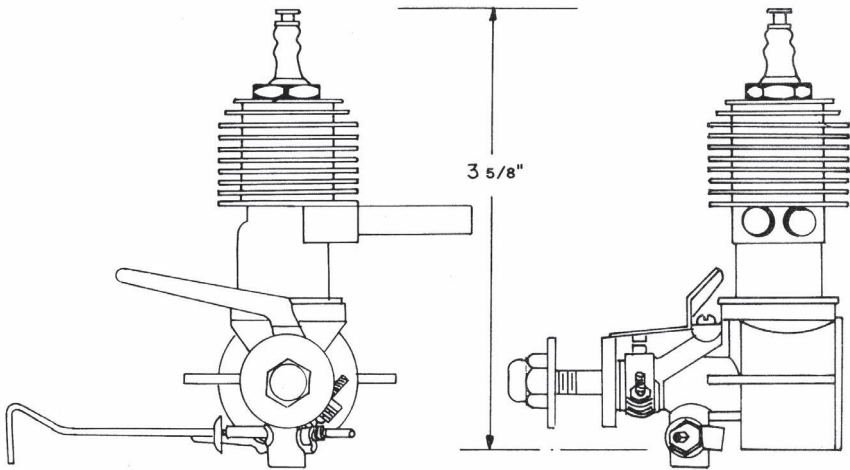
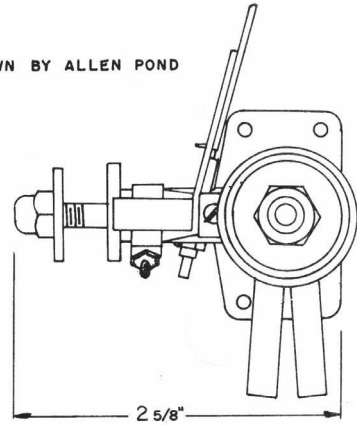

ENGINE OF THE MONTH

This month's engine is one of those local engines that never attained national prominence although used rather extensively on the West Coast. In this case, we are referring to the Micro 19 engine as produced by the Hovsepian Brothers, of Berkeley, California. Strangely enough, the company still exists under the name of the "Model Airplane Co." but the title is completely misleading, as they have nothing to do with model airplanes now.

The Micro engine first made its debut in 1938, with Al Hovsepian flying a model designed by Dick Schumacher called the "Microbe" (tricky name!). This writer, who first saw the Micro engine run, was not overly impressed with this small engine. The big engines, such as the Brown, Ohlsson, Denny, etc., were the reliable motors and for this reason most everyone flew the large models.

With the advent of Class A, Al Hovsepian kept plugging his engine and eventually induced Jack Dyer to use his motor. Dyer, in those days, was one of the few modelers who preferred the smaller size motor. Dyer was able to start and run the engine with some modicum of success, as the motor exhibited hard starting tendencies. (We didn't have any starters in those days.)

When the Ohlsson 23 flooded the market with its excellent performance, the Micro engine, along with many other engine manufacturers (Hal Atkins, Jack Keener, etc.) were promptly bypassed by the modelers desiring reliability and power.

Information was rather scarce on the Micro, so this writer had to lean rather heavily upon Bruce Chandler's analysis of the Micro engine. From a technical standpoint the engine appears to be a .20 cu. in. displacement based on a bore of .64 and stroke of .65. No power figures are available, but a 1/10 h.p. estimate appears to be about right.

The Micro engine, as drawn from engine #107 presently in the Dave Broadsky collection, appears to be quite well built, with good workmanship and finish. The lone drawback to the overall appearance is the timer, which seems rather "Mickey Mouse", with stamped sheet steel housing, stamped aluminum timer arm, and stamped aluminum back plate cam, also serving as a prop drive washer.

Weight of the Micro was approximately 3-1/2 ounces. The basic components of the engine were primarily aluminum: a permanent aluminum mold crankcase, fitted with a bronze bushing, was threaded top and rear for cylinder and back plate attachment. The cylinder, comprised of a thin wall seamless steel tubing, was fitted with a machined 10 fin aluminum cooling jacket. The by-pass was a stamped operation; in this case, quite similar to Atwood's P-30 late model.

Probably the most attractive part of the engine was the 1/4 inch dia. brass tubes that served as the exhaust pipes. These were only pressed into the cylinder exhaust block with no apparent welding. It was a shame to break one of these exhaust stacks off.

The piston design was a little ahead of the times, being flat, ala the much later Super Tigre engines that proved so successful in FAI Competition. Without a baffle plate, starting the Micro engine by hand was no easy chore.

In closing off, it should be noted that the crankcase design shows the influence of Jim Brown, a later manufacturer of the Little Dynamite and Thermite engines. Actually, not many modelers are aware of the fact that the San Francisco Bay Area was also a hotbed of engine manufacturers. However, because of advertising and larger production, most all modelers assume all of the California engines were made in the south.

We will continue to bring all engines to the readers attention, particularly those little known engines of Northern California.

Supercraft
SKYCHIEF

DRAWN BY ALLEN POND

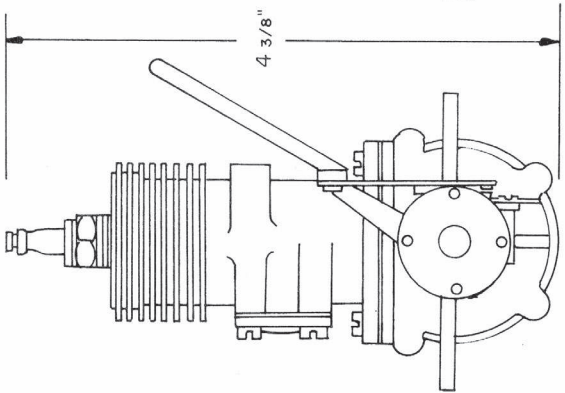
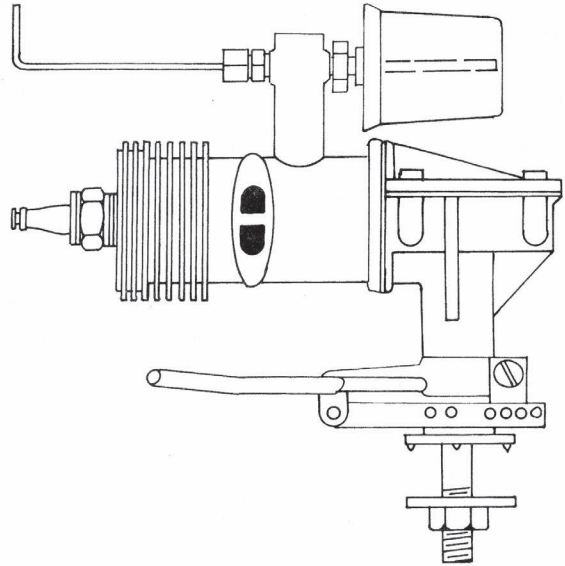
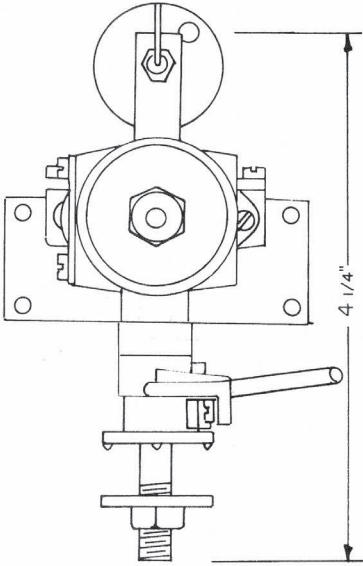
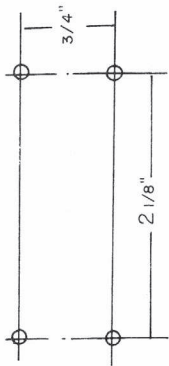

ENGINE OF THE MONTH

Talk about a look-alike, the "Sky Chief", as manufactured by American Supercraft Corp. was practically a dead ringer for the Dennymite engine. It should be pointed out the Sky Chief had a displacement of 52 cu. in., as compared to the Denny engines of 56 cu. in.

In the January issue of *Model Airplane News* (just in time for the Christmas trade), a startlingly priced engine called the Sky Chief was introduced at the price of \$6.95, which included the coil and condenser!! Made primarily of cast iron, this engine was no junk and was absolutely guaranteed to run.

Even the box that the engine was packaged in was a durable item. Matter of fact, it made an excellent parts box, small tool box, you name it. To assist the engine owner, a complete pictorial list of the parts was printed on the inside. There could be no mistaking the part you would need to keep your motor in running condition.

The Sky Chief, a product of the American Supercraft Corp., located at Union and Lake Streets, Chicago, Illinois, was offered through the jobbers who in turn wholesaled it to the dealers. With less than seven dollars to play with, one wonders just what the actual cost of the engine was.

In that same line, the writer, who has known Irwin Ohlsson for all these many years, was startled to hear Irwin say (this was in 1947) that he could produce engines for \$1.75 each. In retrospect this was not an impossible figure, as the Ohlsson firm had acquired all those automatic machining tools during the war to comply with Federal directives in the manufacture for wartime parts provided by O&R. So it would be with a large manufacturing firm like Supercraft.

The engine we are illustrating this month is the 1941 version, which had the two holes in the exhaust instead of the one oval hole. Basic specifications are

bore .0875"; stroke .0875" giving a displacement of .52 cu.in. Base weight was 10 ounces to which you added four ounces for coil, condenser, and batteries. This four-port engine was rated at 1/5 hp at 10,000 rpm, although the manufacturers claimed an rpm rating of 15,000 (probably on a flywheel for a boat engine). Propeller used for the tests was a 13 dia., 7 pitch type.

For those technically minded readers, the Sky Chief featured molybdenum iron cylinders and mating piston; the latter being centerless ground and micro-lapped to one ten thousandth. A heat treated crankshaft, made in three pieces, was made of steel, ground and polished, heat treated to proper strength. The timer, greatly resembling the Dennymite timer, was equipped with a so-called "positive firing" cam. A small low cost type plastic tank was provided along with a positive lock for the needle valve.

Also noted was that the Supercraft people provided their own coil called the Sky Chief "Lightning", but a high tension lead apparently was not supplied.

The first model Sky Chief engines were ringless pistons, which were more expensive to manufacture. In 1941-42, rings were added to the piston and the price raised to \$7.95. Whether this was due to added machining costs (which should have been less) or whether materials were more costly due to the wartime requirements.

Like many engines of this era, World War II effectively stopped most all model engine productions, with the result that many engines, including the Sky Chief, were not manufactured again. Regardless of what was good or bad about the Sky Chief engine, the important thing was that it was the first Class C engine to be sold under \$10.00. This did lead to more competition for price among the manufacturers, which helped out the average model builder's pocketbook.

Knight

ONE CYLINDER ENGINE
MFD BY POWER MODEL BOAT
& AIRPLANE CO.

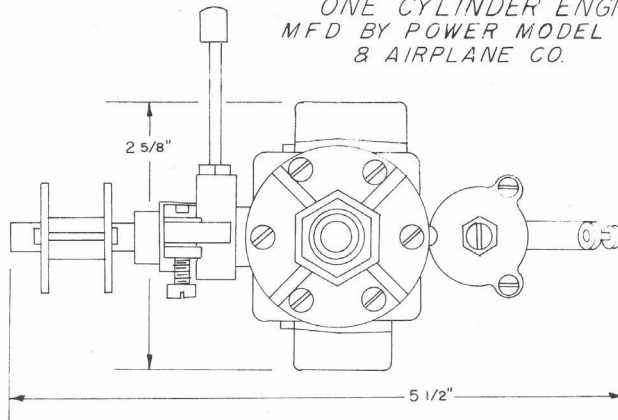

BOSCH PLUG

DRAWN BY ALLEN POND

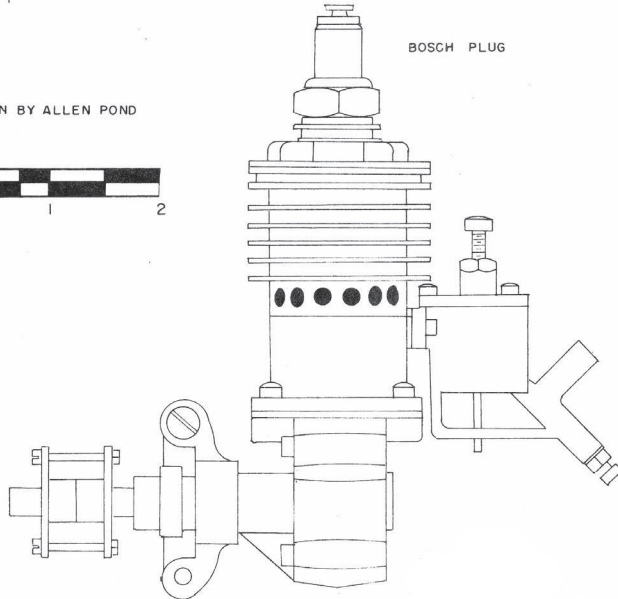

ENGINE OF THE MONTH

The engine featured in this month's column is one of the main reasons that model gas engines were not popular in the early thirties. Until the advent of the light-weight Brown Jr. at 6-1/2 ounces, gas models with these heavy motors were generally heavy and clumsy, easily prone to breakage.

The Power Model Boat and Airplane Co., then located at 134 South Clinton St., Chicago, Illinois, were the manufacturers of typical engines of that era. The engine, which had no name to start with, was designed for boats employing fly-wheels to keep the motor running. The aircraft version was offered by the simple expedient of press fitting the drive washer on a slightly tapered shaft.

First advertisements appeared in the boat oriented magazines. When it appeared, gas models were gaining unprecedented popularity, the PMB&A Co. put out brochures featuring a black knight motif and calling the engine, the Knight Single Cylinder engine. For its day, the motor had a progressive look to it, although it was quite heavy for airplane use.

The engine was made mostly of cast iron with bronze bearings and bronze con rod. Actually, the buyer was offered two versions; one with alloy aluminum and the other in cast iron. (The alum. alloy engine is a very rare engine as very few were made.)

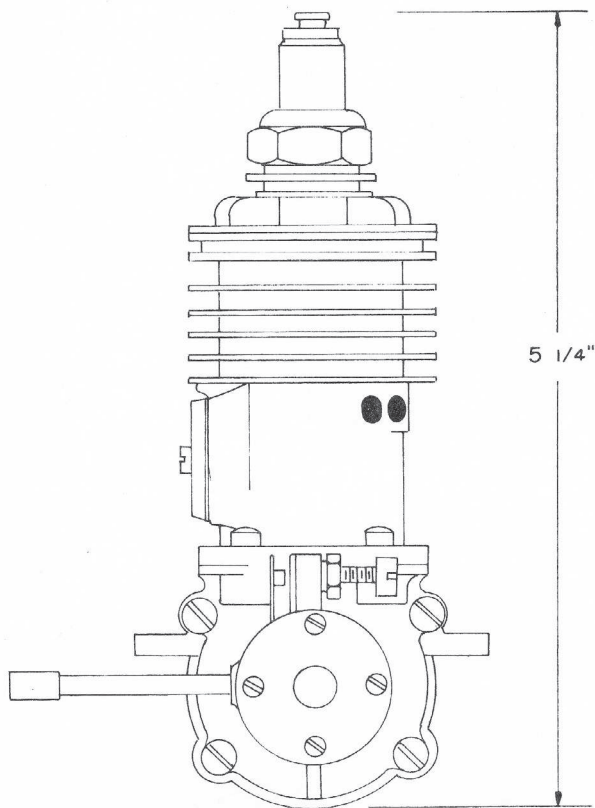

A variety of options were offered. If one was inclined mechanically, he could machine the parts (an alum. alloy casting set for \$5.75 or a cast iron set for \$6.75). If he lacked the expertise and still wanted to build an engine, the finished parts cost \$10.75 and \$12.75 respectively. For those who wanted an engine ready to run, prices were \$18.75 for the aluminum alloy model and \$19.85 for the cast iron version.

Much of the history of this line of motors has been lost to antiquity, but the general consensus is that the engines were the brainchild of Gilbert Knight, who was also responsible for the large Gil (bert) engine. The latter engine was a huge engine that we will feature in one of our later columns.

Rather surprising in spite of its rather modern looks, the engine was only rated on their brochure at 4000 to 6500 rpm. Looking over the engine from the Karl Carlson collection (from which this drawing was derived), the exhaust porting is quite reminiscent of the early Loutrel engines. As in the case of the Loutrel, the exhaust porting was generally insufficient to allow the engine to "breathe" hence the rpm was limited.

Another of the attendant problems in running the engine was the float type carburetor. The check valves were forever giving trouble, in many cases requiring a micrometer to set. Then, too, at any high revolutions, the valves had a tendency to flutter, which would flood the engine. Modern modelers don't know how simple things are today with the spray bar and needle valve setups to run engines.

Advertising brochures claimed the tank supplied was good for 20 to 30-minute run time (the tank must have been huge). This, of course, could only be attained by running the engine slowly, hence, again, lack of power. The recommended propeller for the engine was a 15 inch dia., 10 inch pitch, as produced by the PMB&A firm. For \$2.25, this beautiful walnut prop was cheap for its day!

In addition, the firm also produced boat and airplane kits. The airplane offered was a 90 inch wingspan Stinson Reliant. Kit was priced at \$17.60, which included all materials, plans, and wheels. Weight of the model was an astonishingly light 2-7/8 lbs.

For the technically minded, the Knight engine featured a 1 inch bore with 7/8 stroke, rated at 3/16 h.p. Weight of the aluminum alloy version was 10 ounces, while the cast iron model ended up at 15 ounces. A simple flat type tension arm, provided with the point, allowed for an adjustable gap.

As mentioned before, the cylinder was cast iron or alum. alloy with a cast iron piston having two rings. Later brochures had a different engine, slightly smaller, with 7/8 bore and 3/4 stroke, giving 1/8 horsepower. This was basically the same engine, although specifications only gave 3500 rpm with a 12 inch propeller.

There are not too many of these engines floating around these days, as 50 years is a long time for an engine to survive the scrap heap.

DEEZIL

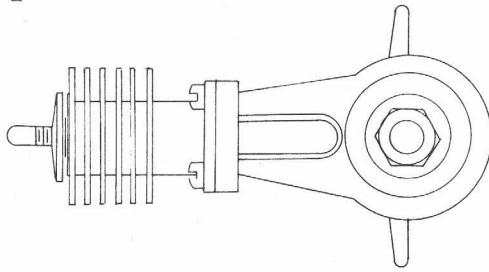
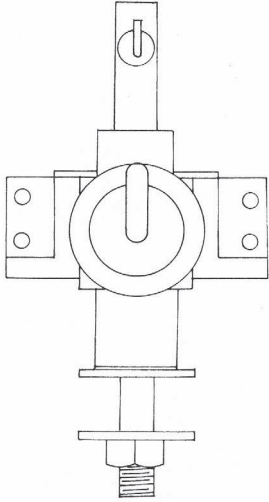
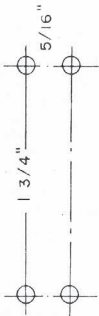

DRAWN BY ALLEN POND

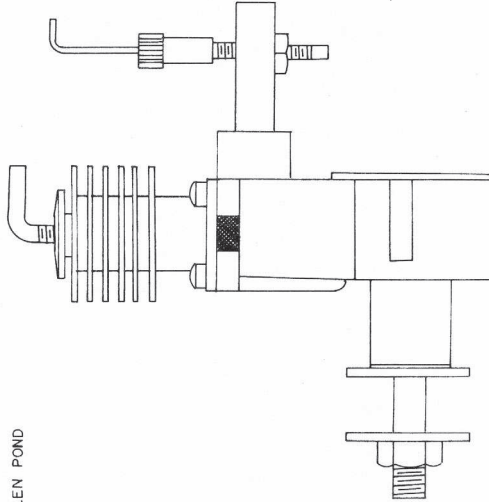

ENGINE OF THE MONTH

In 1947, most every modeler was looking for a way to get around the weight and trouble of the ignition system. One method, as marketed by Art Hasselback of Consolidated, was to sell a nitrated fuel known as "Liquid Dynamite".

Here, the motor was started on an external ignition pack. When the motor had warmed up, the unit was disconnected and the electrode of the spark plug would glow. This eventually led to the production of the glow plug by Ray Arden. Surprisingly, the announcement of this revolutionary way of running a motor was rather quickly announced in the lower section of that advertisement featuring engines and parts in the November 1947 issue of *Model Airplane News*.

Another school of thought, based on the European success, thought diesel engines were (or compression ignition engines, as they really are) the way to go. This was thoroughly exploited by Leon Shulman with his Drone Diesel engine.

Many other companies thought this was the way to go and started producing various versions of diesel engines. In the February 1948 issue *Model Airplane News*, the Gotham Hobby Co., 107 East 126th St., New York, announced a new engine called the "Deezil".

This Class A engine was competitively priced with the Ohlsson 19 and 23, as the O&R firm had just dropped the prices of its motors by over 40%. This action not only caused a rumble with hobby dealers who were stuck with engines at the old price, but immediately undersold all the rest of the engines on the market.

The Deezil was Gotham's answer to both problems; i.e., ignition and price. At \$12.95, this engine was instantly accepted as a real bargain. Incidentally, not many collectors know, but a ball bearing version was offered at \$17.95, but was never produced in quantity as the lower priced engine commanded the modelers purse.

Gotham was flooded with orders and production of engines mounted. As production increased, quality fell off badly, something that cannot be tolerated in a diesel. It didn't take long for the modelers (the competition

oriented flyers) to sort out this engine and proclaim it a "turkey" on the basis of poor workmanship and resultant poor performance.

However, Gotham had invested heavily in this engine and in an effort to recoup its lost sales, the price of the motor was abruptly dropped to \$2.95 in the November 1948 issue of *Model Airplane News*.

This succeeded in prolonging sales until the word finally got around to even the newest tyro in the modeling game that this engine was a bad investment. In some respects, the sale of this engine was quite similar to the drop suffered by the GHQ Loutrel. The latter was saved by four years of war where no engines were available and consequently many a modeler got burnt.

Sales went on for about a year after the price drop, but the handwriting was on the wall. Eventually, sales stopped completely and the engine dropped into obscurity.

The Deezil engine was simplicity itself, with only a variable compression lever to set and a needle valve to meet the flow of fuel. Also offered with the engine was a flock of accessories ranging from propellers at 50 cents to a gamut of items consisting of shut-off valves, spinners, a vibro-tak (!), flywheels, boat couplings, fuel, and many miscellaneous tools.

For the benefit of the technically minded, the Deezil featured a bore of .473 in. and a stroke of .708 in., giving a displacement of .125 cu. in., which stamped it as a Class A engine. Weight of the engine was five ounces, with an overall height of 3-1/2 inches. The cylinder, piston, crankshaft, and connecting rod were made of alloy steel, while the crankcase was die-cast aluminum. The latter, in many cases, were produced so quickly, the flash was still on the casting.

The manufacturer claimed 8000 rpm using a ten inch propeller for free flight. Controline flying called for an 8-10 prop (no rpm figures given) which gave a claimed 1/6 HP (same as the Baby Cyclone!) Rather extravagant claims!

The writer is indebted to Karl Carlson for the use of his engine to produce the accompanying drawing of this article.

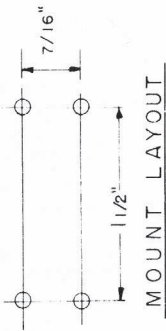

DRAWN BY ALLEN POND

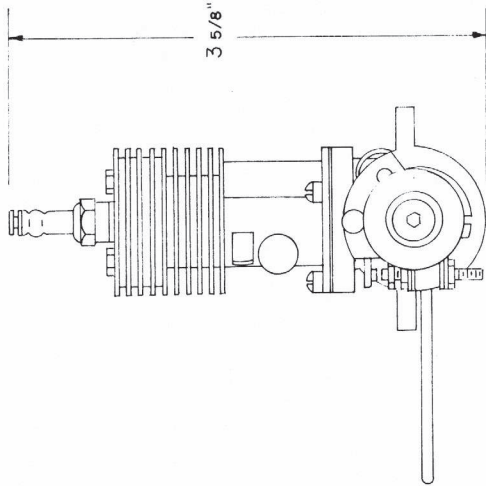
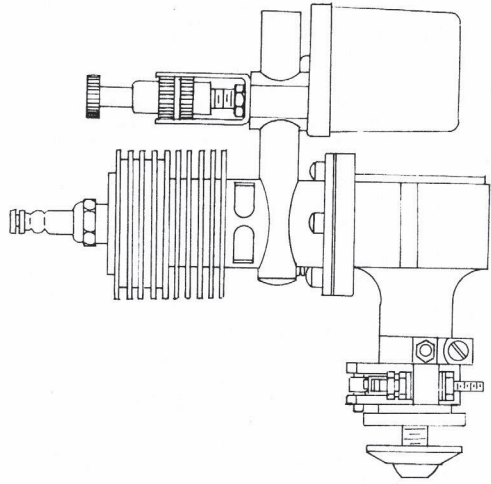
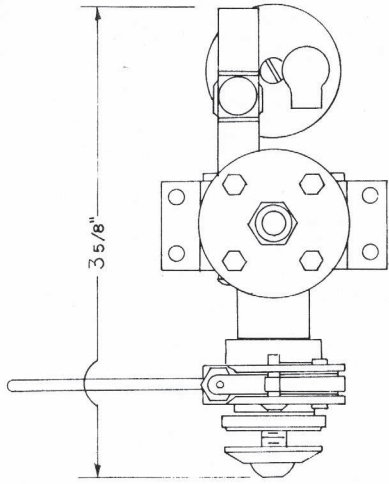

ENGINE OF THE MONTH

You don't really qualify as an old timer if the name Paul W. Lindberg fails to ring a bell. For the benefit of the uninitiated, Paul Lindberg first came to national attention when he became model editor of *Popular Aviation*, then the biggest and best aviation magazine on the newsstand.

Joe Ott first headed up a model section in *Popular Aviation* beginning in 1929. About 1933, due to the press of business, Jack Knoble took his place for about six months. Of course, the "drag" of having to put out a completed model with drawings every month proved to be too much for even the most ardent modeler.

However, Lindberg was more than qualified to accomplish this. A series of half-inch scale rubber models were his first selections to be presented . . . an excellent set of plans that have been plagiarized by more than one kit manufacturer.

Along about 1936, Lindberg became absorbed in the gas engine, and put out his first gassie, the Rearwin Speedster. Although badly out of scale, the model (and later kit) proved to be so tremendously popular that Lindberg embarked on a program of one gas model design per month. The real kicker was that most were very good flying scale subjects!

Eventually Lindberg became involved in the manufacture of kits, sometimes farming out his designs to nationally known firms such as Megow, National, etc. Lindberg himself got involved with solid scale models and I.D. kits for the national defense effort.

This, of course, led to the demise of the model section in *Popular Aviation*. After all, who could follow an act like that? One of the best articles Lindberg did was to feature construction of a model engine known as the Lindberg "Hornet A". This two-part article appeared in the January and February 1940 issues of *Popular Aviation*.

Many years later, John Morrill was looking for a model engine design to produce. After his success with modifying the Garami Simplex engine to the point where it would run quite respectably, John selected the Hornet A as his next project.

In going over the drawings, Morrill immediately found the bore and stroke gave a .23 cu.in. displacement, making it a Class B engine. It was no great problem to reduce the bore, as John discovered the motor as manufactured directly from the drawings did not perform anywhere near to the output of the contemporary engines such as Ohlsson, Bantam, etc.

A lot of hard work and experimentation went into the "re-design" of the Hornet motor. As John says, about the only thing that is exactly the same as the original engine is the name. However, all due credit to Morrill, as all of the features and appearance of the original engine have been maintained.

Probably the trickiest idea John came up with was to have the crankcases made from extruded aluminum rather than make up castings. Although more machining time was involved, the extruded crankcase would be stronger than a casting and the cross section more consistent.

John readily admits to changing the sideport area, timing, and compression ratio. After many hours of comparing notes with many good motor men, John finally came out with an engine that retained all the classic looks and handling of the old motors, but yet would run comparably with the contemporary engines of its day.

For those who are interested in how the engine is fabricated, the crankcase, cylinder head, back plate, timer frame, and tank cover are machined from 6061 aluminum. The crankshaft and crankpin are precision ground, case hardened 1117 steel. Connecting rod was machined from 2024 aluminum. Of course, good old mehanite was used for the piston, to ensure long life.

Technically speaking, the Morrill Hornet features a bore of .625 in. and stroke of .640 in., giving a displacement of .196 cu.in. Weight of base engine is 5.4 ounces. Performance-wise, the motor has turned 10,000 rpm using a 9-4 Zinger propeller.

Morrill wishes to point out, due to numerous changes to Lindberg's Hornet, the Simplex Hornet cannot be regarded as a true Lindberg Hornet, as he does not intend to do this. He freely credits Lindberg for the inspiration for the present engine.

SYNCRO BEE



DRAWN BY ALLEN POND

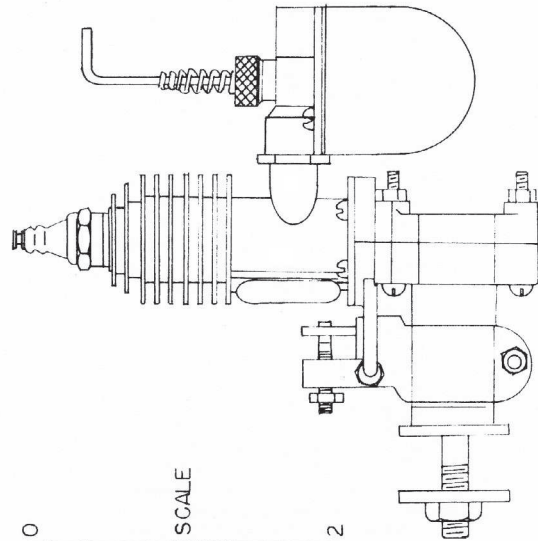
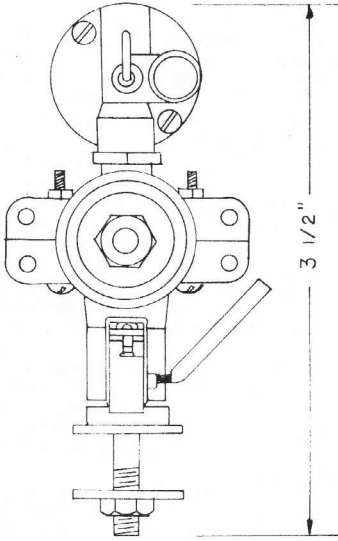
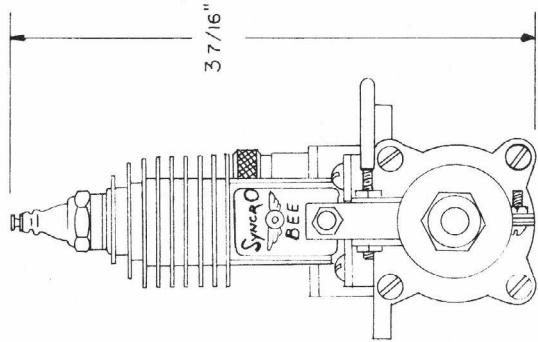

ENGINE OF THE MONTH

This month's engine of the month is that much maligned motor known as the Super Bee, as produced by Syncro Devices, 611 Boydell Bldg., Detroit, Michigan.

The Syncro Bee first made its appearance in the 1938 July issue of Model Airplane News. Attractively priced at \$12.50, this motor was a follow-on to the Syncro Ace.

The reaction of the experts was after the Syncro Ace fiasco, what can you expect from the Syncro Bee? Actually, the motor had two strikes on it before it ever hit the street. The original design by John L. Doll lost something in the transition from prototype to production model.

Actually the Syncro Bee was the forerunner of the Syncro B-30, the first of the "slag engines". From then on, it was Rogers, Thor, Genie, Buzz, ad nauseam. Most all the engines looked so much alike, one wonders what was the correct sequence of motor designs (?).

For \$12.50, the Syncro Bee wasn't a bad buy, as it included coil and condenser. Interestingly enough, the Syncro people marketed their own spark coil known as the "Super Light".

Performancewise, figures are pretty hard to come up with, as apparently no interested party, company, or magazine took the time to run strobatac tests on the Syncro Bee. The Syncro Devices Co.

claimed rpm figures of 1000 to 8000 using a nine to ten inch prop with 6 to 6-1/2-inch pitch.

Specifications of the Syncro Bee shows a bore of 1/2 inch and stroke of 5/8 inch to give a displacement of .122 cubic inches. Weight was 3-3/4 ounces, so-called flying weight of 8 ounces (probably includes B or C size batteries).

As far as metallurgy went, the later Bee models featured a "chapmanized" steel piston. This gives a very hard surface for long wear. This improvement did not seem to alter the performance appreciably.

One feature of the engine was the split-type crankcase held together by four bolts, which allowed for quick disassembly and inspection of the front bearing.

Reading of the operating instructions gleaned a few interesting facts, to wit: They sold no partly finished knock down kits, something which was employed by later slag motor manufacturers to help spur sales.

When a motor was returned for repairs, a 50 cent charge was made for inspection. The guarantee covered workmanship and materials. One wonders what the actual production cost of the engine was, in light of similar charges by other manufacturers such as Scripto pens asking for 35¢. This was more than the cost of manufacture!

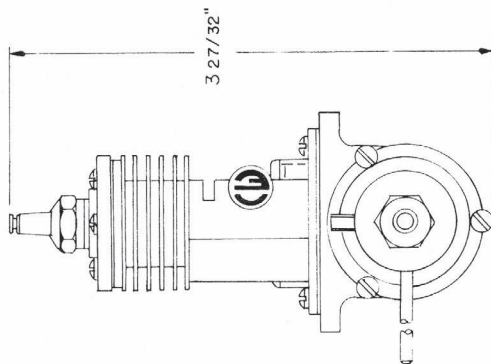
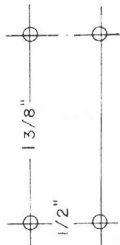

DRAWN BY ALLEN POND

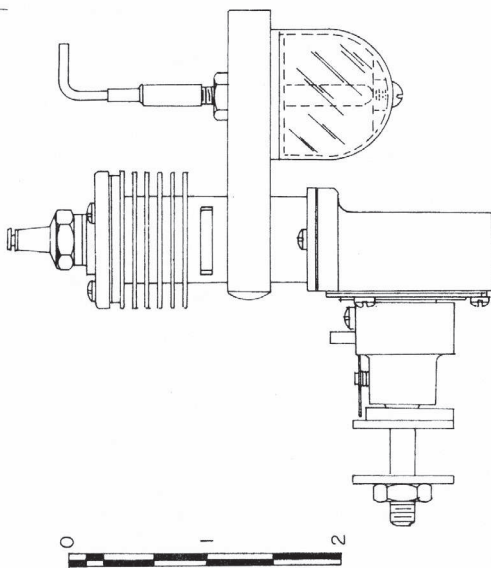
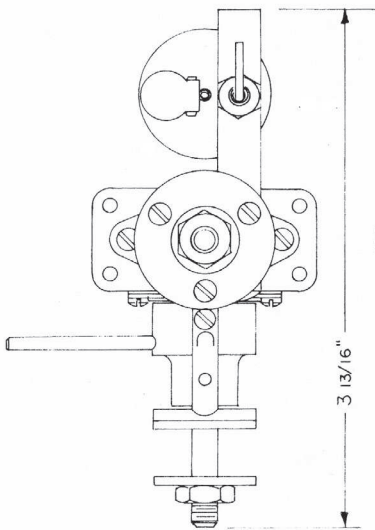

ENGINE OF THE MONTH

This month's engine is another one of those look-alike engines as put out by the Cobey-Waite Co., 335 E. Price St., Philadelphia, PA. The 1946 Cobey-Waite "Cobra", as it was called in those days, was a dead ringer for the Madewell 14. This engine is often referred to as the "Post War Madewell".

Regardless of whether Jack Keener (designer of the Madewell) inspired their engine or not, the engine had a very short life on the market. Actually there was a follow-on engine called the Scout, on which we have even less data.

The Cobey-Waite appeared in the "Engine Construction Data" article by Edward G. Ingram (Model Airplane News, April 1947). He reports as follows:

"The latest offering in Class A is the Cobey-Waite, which has a displacement of .147 cu. in., is rated at 1/10 h.p. at 8500 rpm (manufacturers figures), and is stated to weigh 3-1/2 ounces. Bore of this engine is .562 in. with a stroke of .593 in., practically a square engine, this type coming into popularity based on the success of the racing engines then dominating the field. A compression ratio of 4.5 to 1 was used."

For those who are interested in the metallurgy, the cylinder was steel honed to a piston of the same material. Grinding accomplished the finish. The cylinder head, connecting rod, and a die cast crankcase were all aluminum alloy.

The brochure put out by the Cobey-Waite people was absolutely top drawer, with three-views and a sectionalized elevation. Instructions for starting and running the engine covered a complete page in this slick paper brochure. One could apply the directions to most any ignition engine of this period.

Careful research among the various model magazines has failed to turn up much information on this little known and short lived engine. Just another engine that succumbed to the pressure of the big manufacturing concerns.

**CLEVELAND
TOM THUMB**

DRAWN BY ALLEN POND

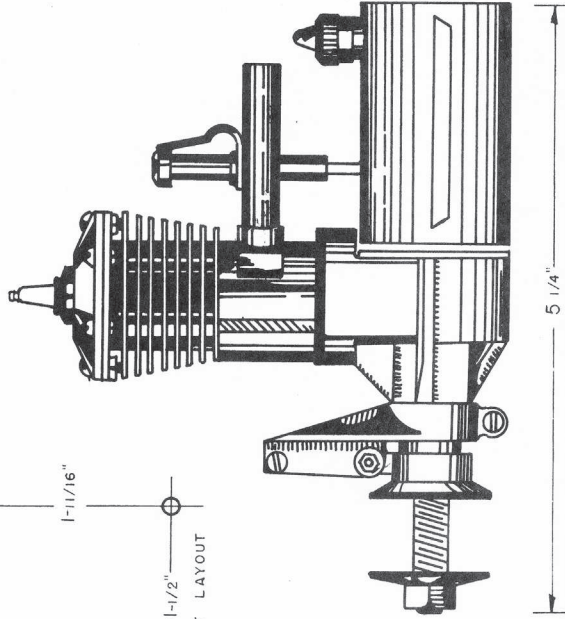
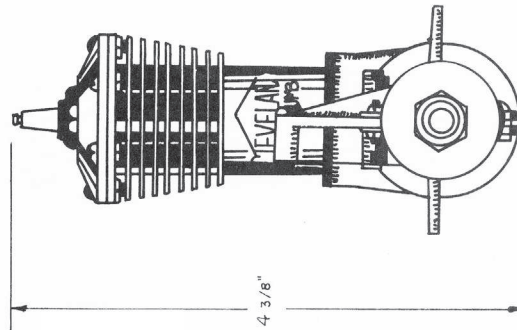
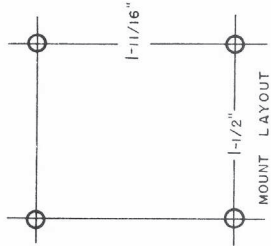
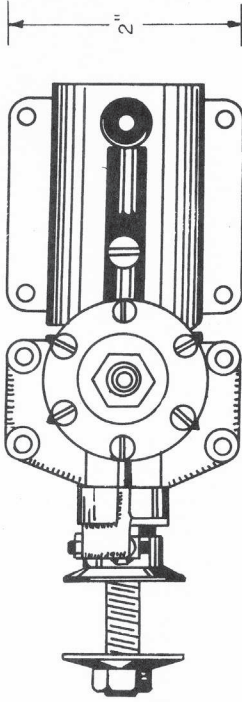

ENGINE OF THE MONTH

One of the earliest companies to feature a gas engine to complement their gas powered kit models was the Cleveland Model Supply Co., then of 1866 N. 57th St., Cleveland, Ohio. Reginald Denny, on the West Coast, was the other manufacturer to feature a combination motor-kit, but that is another story we will feature in a subsequent issue.

The first advertisement appeared in the November 1937 issue of *Model Airplane News* announcing the availability of the new "Tom Thumb" engine. The prospective buyer was offered two ways to go, in ready-to-run form at \$17.50 or the kit style at \$9.75.

There was no doubt about who was producing this engine for Ed Packard of Cleveland. The engine was a carbon copy of the "Muff-head" Mighty Midget engine. Interestingly enough, the Tom Thumb was marketed in the same manner as the Bunch people; i.e., assembled or in kit form. However, the Cleveland engine was priced higher.

The Instruction Manual which accompanied the Tom Thumb engine was very heavily based on the Bunch Model Airplane Company's *Mighty Midget Brochure*. All features of the *MM Manual* were adopted in the Tom Thumb brochure even to the instructions on how to carve a "Tom Thumb" (Mighty Midget) propeller. No questions about it, the Cleveland Co. had picked a thoroughly proven engine to go with their new Stinson Reliant and Rearwin Speedster gas model kits.

The drawing of the Tom Thumb engine we are presenting this month is actually a simplified version of the original plan. The original three-view drawing showed methods of assembling the crankshaft, connecting rod, and piston. The wiring was shown both in the form of a wiring diagram and a pictorial hookup on the three-view. Special emphasis was made on this point, as many a modeler will recognize the majority of engine starting problems was the weakness or lack of spark to the plug.

Not many of the old timers will recall the old way of describing carburetion in those days, regarding only "four-

cycling" for slow running and "two-cycling" for top power setup. In the early pamphlets, running of motors was described as "Rich" (sluggish and cool), "Normal" (correct and reliable), and "Lean" (sensitive to temperature, hot, and unreliable). Operation of the gas needle valve was outlined stating that a "4-cycle" running could be obtained by screwing the needle valve out, producing a considerable amount of smoke. On the other hand, screwing the needle valve in produced extreme speed with a very clean exhaust. To this writer, it is amazing that 45 years later, many modelers still don't know the difference!!

Performancewise, claims were made for 500 to 7500 rpm using the "Tom Thumb" propeller. However, these figures could vary considerably depending on the skill of the modeler carving the propeller and the particular airfoil and shape of propeller selected (assuming 12 in. diameter was maintained).

The Tom Thumb specifications were very slightly different from the *Mighty Midget*, with a 7/8" bore (instead of 13/16") and a 13/16" stroke. Flying weight probably with two standard flashlight batteries) was listed as 18 ounces.

Like the *Mighty Midget*, the Tom Thumb engine was made of steel with aluminum alloy crankcase. Surprisingly, the head was of lead, presumably for better heat dissipation. All bearings were bronze, SAE64 specification. The coil was the standard Bunch coil, supplied with a Bubulier condenser.

The Tom Thumb engine was no "hokey" engine like the later "slag" engines that followed in the early forties. However, with the closeness of design to the *Mighty Midget*, the Tom Thumb engine really offered nothing new except for the highly regarded C-D emblem, a symbol then of good quality.

Around 1938, Bud Warren took over the Tom Thumb line of engines that were stockpiled in the Bunch manufacturing plant. With on-the-field demonstrations and good publicity, Warren was able to maintain a steady flow of sales until the outbreak of WWII. At the close of WWII, the engine was never produced again, as the newer designs had passed it by.

SKY CHARGER

DRAWN BY ALLEN POND

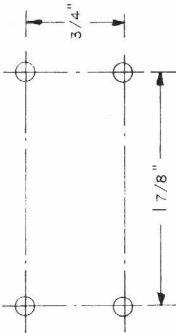

MOUNT LAYOUT

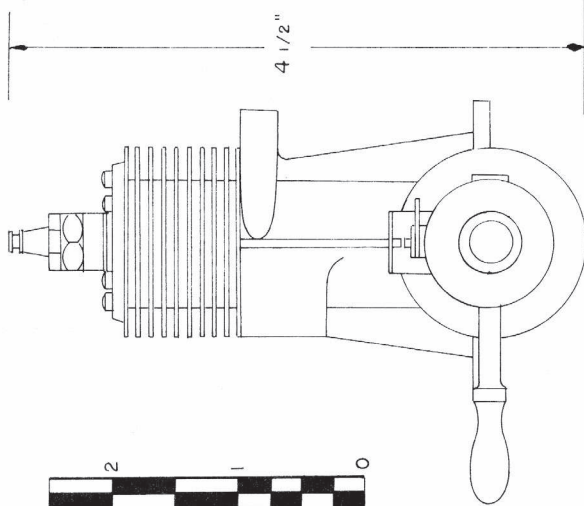

BROWN JR.
SPARK PLUG

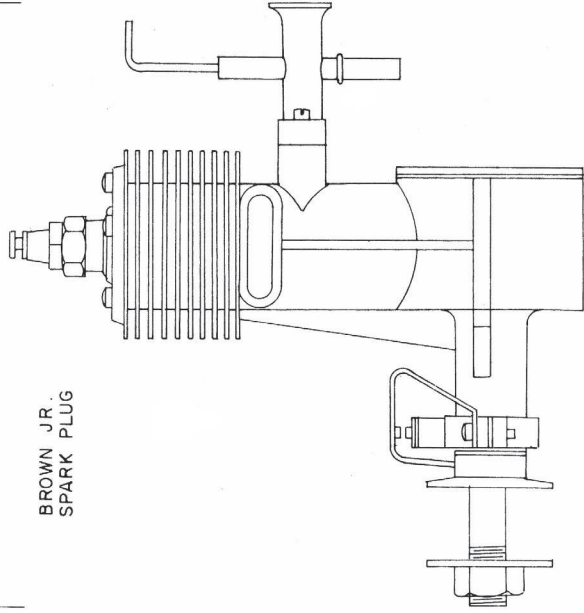
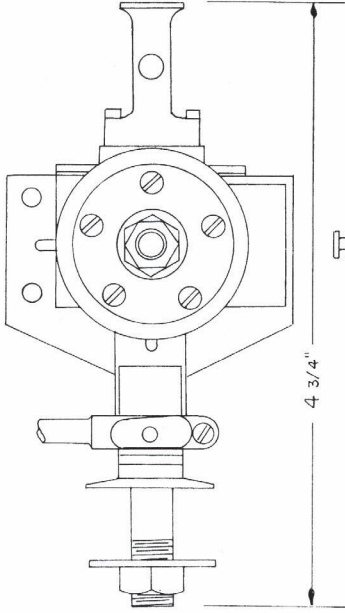

ENGINE OF THE MONTH

One of the most interesting engines to the engine collectors is the "Sky Charger", as originally announced by the Reginald Denny Co. in *Model Airplane News* from the January to April 1937 issues. Suddenly there was absolutely no news and no full page advertising as had been done in the previous issues. The highly advertised content using the Denny motor was shelved.

The mystery deepened even more when the Reginald Denny people again took a full page ad in the December issue of *Model Airplane News* extolling the virtues of their new engine, the "Dennymite". What had happened to the "Sky Charger"?

Well, thanks in part to Bob Veir of California Hobby Distributors (successors to Reginald Denny Industries), and to Jim Dunkins who wrote a tremendous article on the line of engines in the January-February issue, 1969, (#30), of the *Engine Collectors Journal*, we have been able to piece together a story of what happened.

With most of the kit manufacturers producing models to suit the availability of engines, Brown Jr., Ohlsson, Bunch, etc., Reginald Denny decided he must have an engine to complement his very successful Dennyplane model.

Denny then issue a set of engine specifications to various manufacturers, with the proviso all test engines (generally ten to a dozen) would run trouble-free for fifty hours. This running figure came from real full-size aircraft engine tests. Denny figured if this was good enough for the man carrying aircraft, his engine should be no less in quality.

One of the companies that responded to the Denny request was Aircraft Industries of the Curtiss Wright Technical Institute, Grand Central Airport, Glendale, California. President C.C. Moseley had his boys (Atwood, Anderson, Hassad, et al) cook up a design. In short order, twelve engines were delivered to Denny for the 50 hour test.

When it was found by the tests the Sky Charger (as produced by the makers of the Baby Cyclone) could not pass the 50 hour requirement without breakdown, this left Denny Industries in a spot as they had embarked on a rather extensive advertising campaign. All due credit to Reginald Denny should be given as he steadfastly held to his original specification. Actually, the Sky Charger ran quite well and could have been marketed except for the promised 50 hour duration figure that Denny was hoping would attract sales on the basis of proven reliability and durability.

About this time, Walter Righter had designed a model engine that ran quite well. Righter was looking for a buyer and heard about the Denny requirement. Righter quickly produced ten engines and the rest is history; the Dennymite engine was born. The rugged cast iron parts easily passed the wear test.

We are indebted to Bob Veir, of California Hobby Distributors who kindly allowed this writer to remove the Sky Charger from the Dennyplane that has been on display at the various trade shows all these years. The engine we have borrowed has #9 stamped on the case and #12 on the backplate. This was probably the result of switching parts during the long runs. The only other Sky Charger known to this writer is #8 in the Larry Boyer collection, i.e., at last reports.

Actually, the Sky Charger was a very ruggedly built engine with full length reinforcements running from the fins to the mounting lugs. Inspection of the motor reveals the only weak point of the motor appears to be in the spring leaf ignition system. This arrangement, based on a Baby Cyclone design, would never have lasted the 50 hour requirement.

One interesting feature of this engine was the needle valve body and intake

tube being cast in one piece. Of course, production methods would have eliminated this by drilling the intake tube for a removable needle valve so necessary for inverting the motor.

The Sky Charger, according to Joe Wagner's *Model Engine Index*, has a displacement of .573 cu. in. As measured at Replica Engines (Carl Carlson), a stroke of .8125 and a bore of .75 gives a .358 cu. in. displacement. This is very similar to the Baby Cyclone in size (.37). In any respect, the engine never made a full production line, as the Baby Cyclone was still selling very good.

A noticeable Ira Hassad feature on the engine is the five-bolt arrangement on the cylinder. Also, the propeller drive washer had ten holes (a multiple of five). Any Hassad engine collector will recall Ira's penchant for the use of five or ten divisions in his engines. (At one time, every motor manufacturer worked for C.C. Moseley; Atwood, Ohlsson, Anderson, Hassad. What a design team!!)

A typical Baby Cyclone practice incorporated in the motor was the left hand thread on the retainer screw holding the connecting rod on the crankshaft.

The engine also was made with a cast iron sleeve with a specially machined piston consisting of an aluminum top pressed into a steel sleeve. The wrist pin pads were then drilled and tapped into the piston top extending into the piston sleeve. The wrist pin actually held the top of the piston in place!!

Another neat gimmick was the drive washer being screwed unto the 3/8" dia. portion of the crankshaft and then pinned in place. That one would never come loose!

In retrospect, the engine was quite advanced in concept for its time. Truly a shame the ignition system wasn't as rugged as the rest of the engine!

Flush SUPER ACE

DRAWN BY ALLEN POND

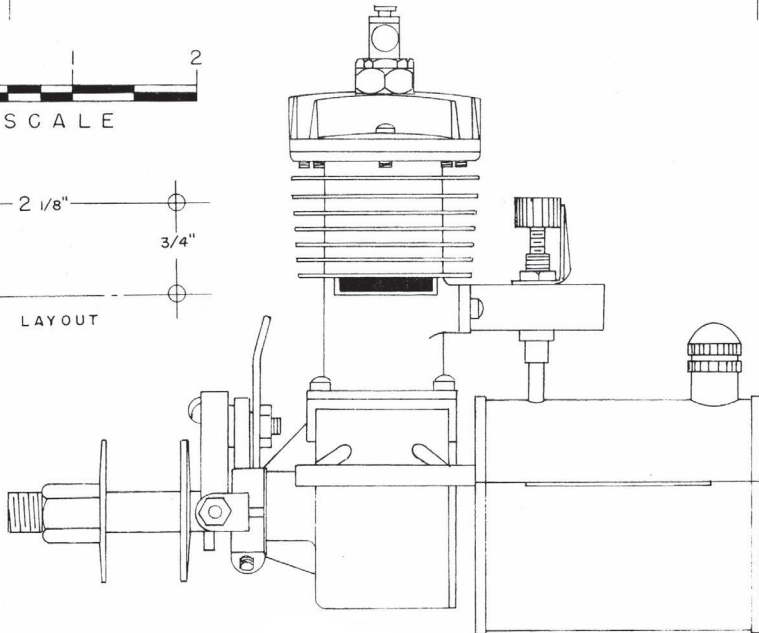
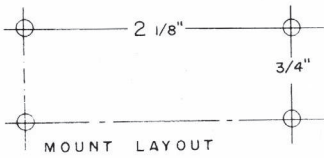
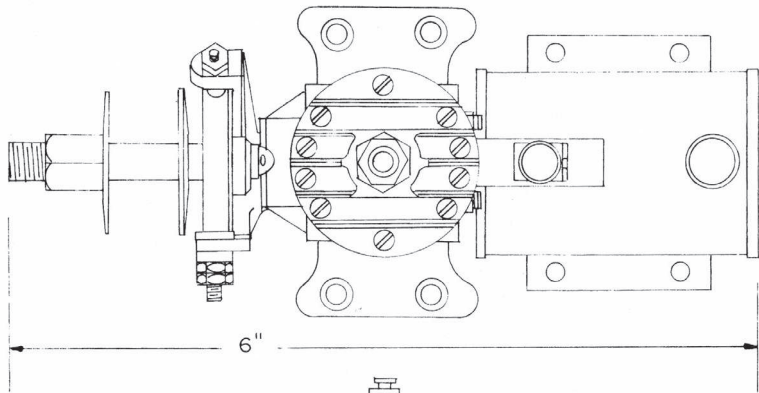

ENGINE OF THE MONTH

"Nothing succeeds like success" could well be the motto of the Tlush engine, as it was comparatively unknown, even on the East Coast where it was being manufactured by the Tlush Brothers.

The "success" this writer is referring to is the win at the 1936 National Model Airplane Championships, held at Wayne County Airport, located about twenty three miles southwest of Detroit.

Francis Tlush entered his 9 ft. model, somewhat resembling a Cavalier, and rode to victory in the Texaco Event (age limit 16 to 21) with a beautiful flight of 45 min., 34.5 seconds. According to some of the eye witnesses at this meet, Tlush's model was on its way down around the twenty minute mark when it encountered another gorgeous thermal that carried the model to victory.

Up to this point, most of the information surrounding the performance of the Tlush engine was extremely sparse, as little or no advertising was done. The results of the Texaco Event on page 45 of the September 1936 issue of *Model Airplane News* was opposed on page 44 with one of the first advertisements extolling the virtues of the Tlush "Super Ace." Interestingly enough, the engine was priced at the same level as the Brown Jr., \$21.50. Only one more ad followed, in the November issue, and little was heard from the plant thereafter.

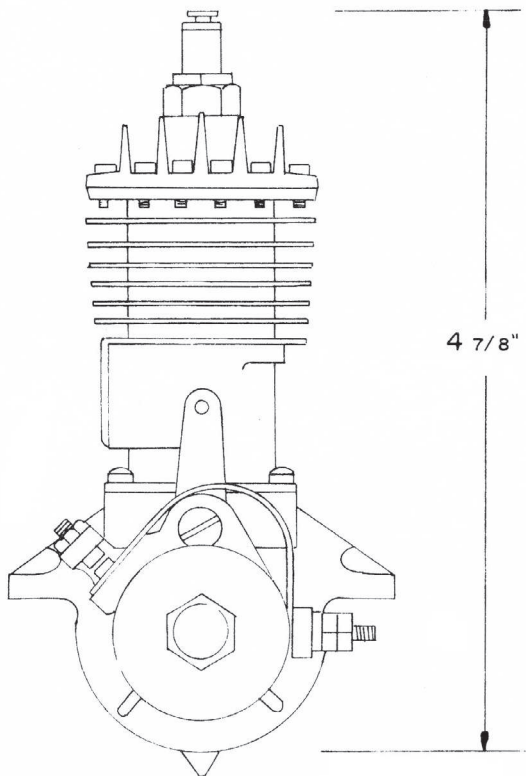

In spite of the non-advertising, the engine was produced until the war shut off material in 1941. In defense of the Tlush brothers, it must be pointed out that the reaction to their ads was rather poor. Estimates have been made by Francis that no more than 500 units out of the 7000 castings were sold in the United States.

Sales abroad were quite another story, as the majority of their motors went to South Africa, and particularly, Australia. As a matter of fact, the Tlush engine was so popular, an identical copy was produced in Australia, called the "Whirlwind." Some of these have come through the U.S. customs, and a few of the engine collectors have this particular version.

Actually, the design of the Tlush motor was taken mostly from Louis Loutrel's engine of the same name, Loutrel, until taken over by G.H.Q. Model Airplane Co. In 1934, the first Tlush engines were tested locally and found to be as good if not better than the Brown Jr. The main drawbacks to the Tlush was the weight of the engine, 16 ounces with all ignition gear. This discouraged local sales, but did open the door for export sales, where weight was of no particular importance.

It was during the old timer events held at the Willow Grove Nationals in 1969 that enough engine collectors were able to convince Frank Tlush to put together another hundred engines from the few castings left. These were priced at \$125, and were quickly snapped up by the MECA members. However, to this day, this writer has been unable to find anyone who is presently using a Tlush engine in his O/T oride and joy.

For the technically minded, the Tlush Super Ace engine featured a 7/8 bore and 1 inch stroke, giving a displacement of .60 cu. in. Horsepower rating was the same as contemporary engines of its day (Brown, Loutrel), at 1/5 H.P. Power ratings were rather vague, as specifications gave 900 to 12,000 rpm speeds without mention of propeller size. Total weight, with coil, condenser, and mount, was given at 16.5 ounces, while the bare motor was rated at 7 ounces.

The Tlush Super Ace featured an aluminum head, alloy (magnesium) crankcase, cast iron piston and cylinder, with an SAE alloy steel crankshaft, heat treated and ground to fit. The coil, made by the Tlush people, was quite light, being only 1-1/2 ounces, when compared to contemporary coils of Bunch, Brown, etc.

An interesting gas tank was fitted to the Tlush, the lower end being made in triangular form with a round top. No question of the gas feeding in a steep climb!

All in all, the Tlush was a good engine. Just another well made gas type that was passed up by the competition.

FREENEY CYCLE



DRAWN BY ALLEN POND

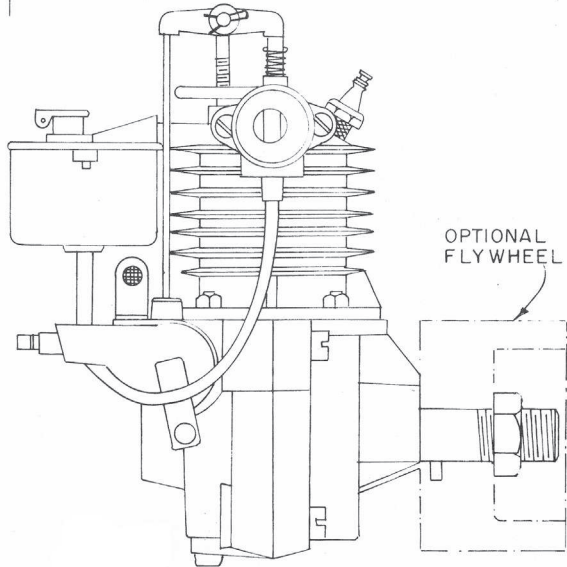
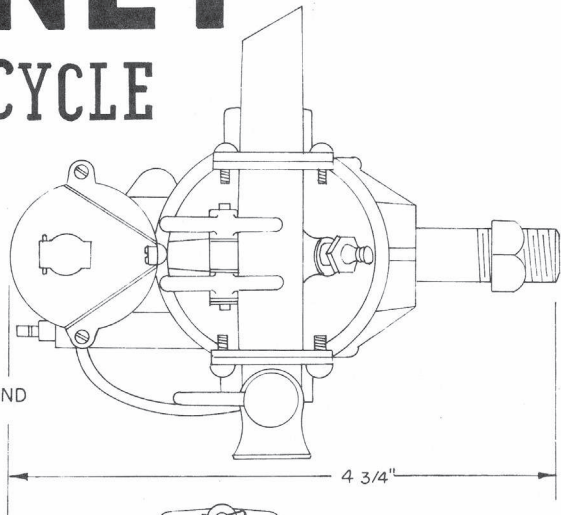

ENGINE OF THE MONTH

In many respects, it is ironic how the four-cycle engines, built by various Japanese firms (O.S., Enya, Saito, etc.), have caught the modern modeler's fancy and are heavily used in old timer Texaco Events and flying scale contests.

Back in the late thirties, a modeler-turned-machinist, produced a four-cycle engine known as the Leja 4-cycle, named after its developer, Casimer Leja. This engine, the subject for this month's column, is called the Feeney 4-Cycle.

Leja caused a small sensation with his engine when he first appeared on the contest fields, but unfortunately, he was never able to make any flights that would be considered competitive. Most modelers, after looking at the engine, would give up any thoughts of operating his engine, as the two-cycle counterparts were hard enough to get running reliably.

During the development stages of this four-cycle engine, Jack Feeney became quite interested in the possibility of producing this engine. Casimer Leja, not having the capital necessary to finance the production, sold the design and manufacturing rights to Feeney, who promptly made plans to start marketing the Feeney (as it was renamed) in the 1939 season. A rather ambitious program of engines was first introduced in April of 1940. Three engines (or models) were presented, each at the same price, \$29.50:

Model A:
20 cc (1.8 cu. in.) displacement
1-3/16" bore
1-1/16" stroke
2/3 H.P.

Model B:
15 cc (.914 cu. in.) displacement
1-1/16" bore
1-1/32" stroke
1/2 H.P.

Model C:
10 cc (.617 cu. in.) displacement
15/16" bore
7/8" stroke
1/3 H.P.

Also offered were the casting kits at \$13.75, which included spark plug, coil, and condenser. Setting up business under the name of Feeney Engine Co., 2700 South Michigan Ave., Chicago, IL, it wasn't long before the engine cost jumped to \$49.00. About this time, the firm moved to 1516 South Wabash in the same city.

To help spur sales, engines were offered on a basis of \$15.00 down, the balance due when the engine was completed and ready for delivery. Also at this time, the Model A engine was being offered for radio controlled ships and similar large models.

Operation of the four-cycle engine was truly "four-cycle" as the oil was not mixed with the gasoline (aviation gas of 80 to 90 octane was recommended). In its stead, the oil was placed in the crankcase and periodically checked. Changing oil frequently was also recommended although no indication was given of how often.

A rather neat idea was evolved on the Feeney engines, which allowed you to buy various parts of the A, B, and C models to make the changeover to any size engine desired. The firm's claim was that these were "screwdriver" kits, as it was stated to be so simple to change. In short, you could have a "3-in-1" engine.

For those interested in the manufacturing features of the Feeney engines, most all parts, (crankcase, cylinder, etc.) were made of aluminum alloy (type not specified). The connecting rod was also heat treated aluminum, as was the piston. The crankshaft, made of aluminum-bronze, featured a worm timing gear on the end of the shaft, hobbled to give one piece construction.

Valves and rocker arms were of heat-treated aluminum-bronze, but the push rods and tappets were still alloy. Interestingly enough, the push rods could be lengthened (or extruded) slightly by hammering the rod-while rotating it on a flat surface. Clearance was recommended at .007 clearance. As they noted, as clearance is decreased, the engine can be run at higher R.P.M. By increasing the clearance, the engine will idle better.

For summarizing the Feeney (Leja) 4-cycle engine, the old saying, "Born thirty years too soon" was never truer. This columnist is indebted to "Red" Garlough, the District 2 MECA Coordinator, for his generosity in allowing us the use of his Feeney engine. We are sure this engine should be of interest to all.

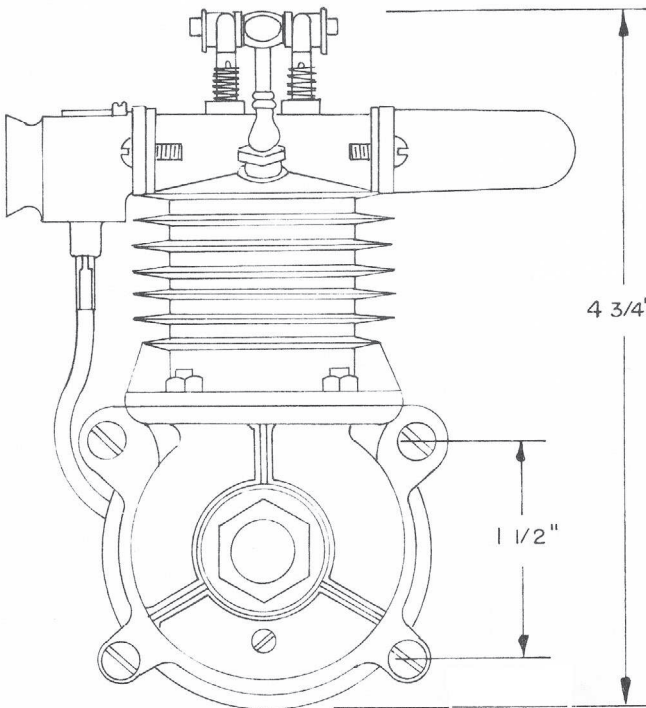

McCOY "19"

DRAWN BY ALLEN POND

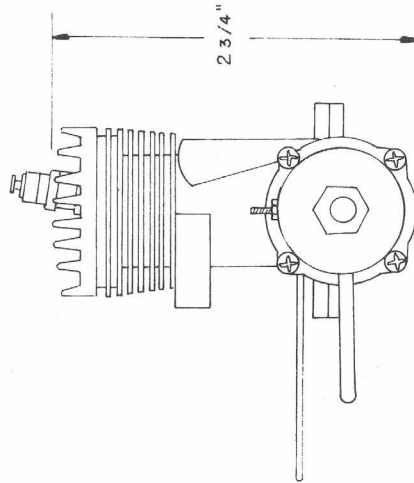
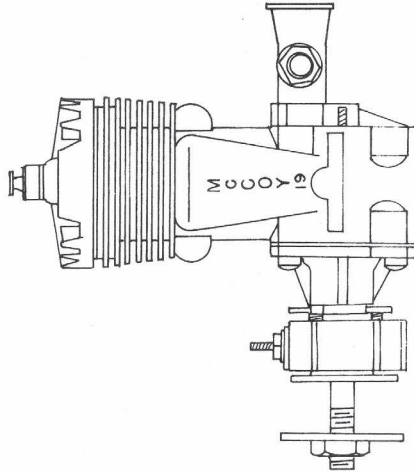
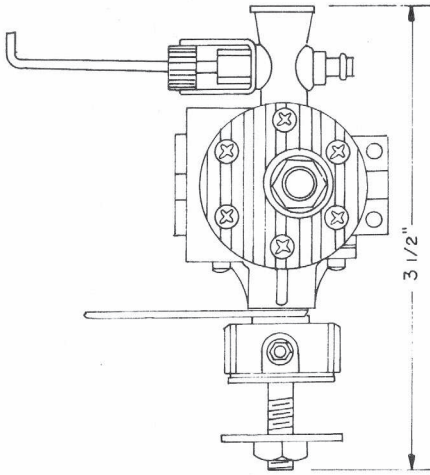
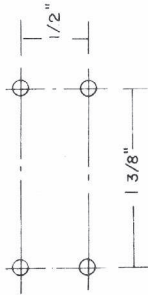

Engine of the Month

This month's engine is the ignition version of the McCoy 19. Not too many modelers were aware that the Duro-matic Corporation actually put out such a version.

Of course, with the glow plug gaining such popularity based on ease of starting and operation, in less time than it takes to tell about it, all engines were converted to glow (sometimes with disastrous results) to capitalize on the latest trend. McCoy engines (as were K&B Torpedo engines) were ideally suited for worth his salt. McCoy 19 powered Zeek type contests were quite popular on the West Coast. It was quite some time before K&B was able to overtake the McCoy 19 engine for popularity with their new Green Head 19.

The McCoy 19 engine we are illustrating is the ignition version. At the time of review (Flying Models 1950), the three-views shown were of the glow version. A point was made that the engine was offered in two models: ignition or glow. Naturally, most competition oriented modelers chose the glow version.

No question about competition bringing out the best in manufacturers, as the tremendous craze for control line flying made exacting demands for performance and durability in model engines. The McCoy 19 was an ideal example developed from the requirements for a low priced high performance engine with beautiful die cast parts.

As was the design feature in the McCoy 60 and 49, the cylinder block, including the crankcase and intake tube, were cast in one-piece aluminum. The

disc rotor valve was also an aluminum casting mounted in the main crankcase by a stub steel shaft. Also of aluminum was the front crankcase plate which was secured to the main crankcase with four Phillips head screws. This particular McCoy had a steel shaft in a full length bronze bearing, a departure from the usual practice of ball bearings.

The only other item that was not aluminum was the steel sleeve force-fitted in the crankcase block. Of course, this was fitted to an aluminum piston machined to accept two cast iron rings. Interestingly enough, the steel crankshaft and counter-balance were machined as one piece.

The McCoy 19 engine also differed from the larger McCoy engines by the use of a spray bar type of fuel induction. Claims were made that even the rankst beginner could start this engine easily.

To say the least, the McCoy 19 was attractively priced at \$10.95 for the ignition version and \$9.95 for the "hot point" (glow) ignition. Early engines came with the standard red head, a trade mark which was quickly abandoned as the demands of production did not warrant the extra time and expense.

The McCoy 19 featured a bore of .625 and a stroke of .630, giving displacement of 195 cu. in. Weight, excluding tank, was about four ounces. Performance was sensational, being rated at 1/3 h.p. at 14,600 rpm. Using glow fuel, the engine ran at 12,300 with a 10/4 O&R prop, 10,500 rpm with an 8/8 Power Prop, and 10,200 with a 9/6 Power Prop. That engine could run!!

LUCAS & SMITH

CONTESTOR

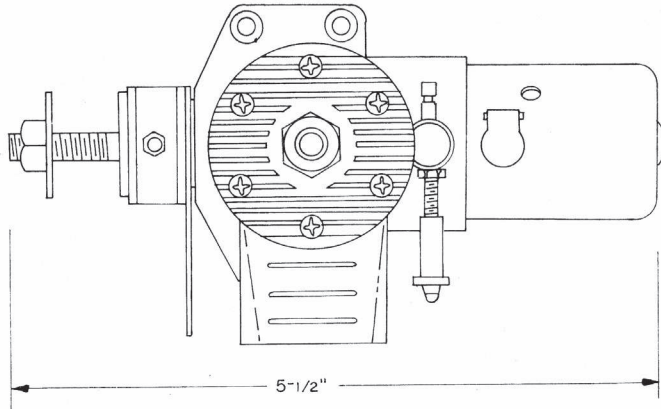

DRAWN BY ALLEN POND

SCALE

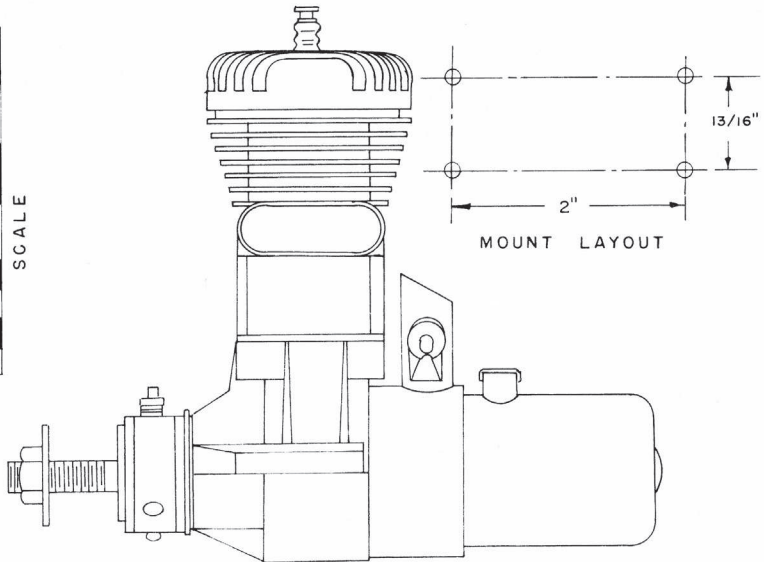

ENGINE OF THE MONTH

This month's engine of the month was the last hurrah for Danner Bunch, as far as engine design and manufacture went. During the war, Danner had sold off all his engine rights and parts to various people.

During this time, Danner, like a lot of other engine designers, spent his time developing an engine that would be superior to all others. However, it was not until January 1947 that the first advertisements appeared for the Contestor. Bunch had found backers, Lucas & Smith, located then at 2636 Humbolt St., Los Angeles, CA, to produce his first post-war engine, the drum rotor version priced at \$28.50 for the D60R model.

Sales were not the most encouraging at this time. In the July 1947 issue, the L&S firm announced a new price of \$18.50 for the engine less coil and condenser. However, this was not in time, as the following issue, Ohlsson & Rice pulled the rug out from under practically every engine manufacturer by reducing their Ohlsson 60 from \$18.50 to \$11.95. With Ohlsson's unimpeachable reputation for good engines, no manufacturer could compete with an excellent engine priced so low. Not only was the 60 size engine reduced in price, but also the entire line of Ohlssons. Many a manufacturer went under when faced with competition like that.

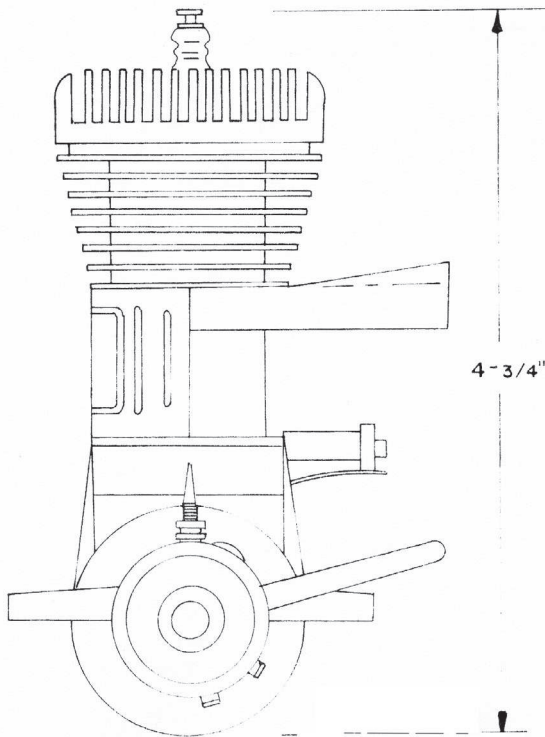

In a last ditch effort to regain the engine market, a variance of the Contestor was introduced, looking for all the world like a large size side port Bunch Tiger. There has been considerable speculation by the modelers who own these versions as to which runs the best. This writer regards the sideport as less troublesome and possibly easier starting.

Regardless of the engines being offered in two versions at a reduced price, the O&R price change doomed all but the well heeled manufacturers. Companies like Duromatic (McCoy), K&B (Torpedo), Herkimer Tool (O.K.), etc. were able to continue and compete with the new prices.

The Contestor was actually a pretty fair running engine, rated all the way from 7,000 to 14,000 rpm. Half horsepower was claimed, but no strobatic tests are available to indicate the optimum propeller size.

The Contestor 60 was actually .596 cu. in. displacement, sporting a bore of .945 in. and a stroke of .850 in. Weight was 11 ounces, considerably under the other big engines such as Spitfire, Hornet, McCoy, etc.

For those who have a technical quirk, the engine featured a polished cast aluminum head with fairly large cooling fins. The cylinder followed the standard Bunch practice of being carbon steel with by-pass and exhaust silver brazed in place. The cylinder is then broached and honed to final fit.

One interesting gimmick was the two rings, claimed to make for more positive starting and long lived compression. Crankcase was die-cast aluminum alloy employing a one-piece hardened steel crankshaft. To prevent connecting rod failure, this item was produced from drop-forged chrome moly steel.

Embittered by his lack of success, Danner Bunch died shortly thereafter, with many saying by his own hand.

MADEWELL 14



MOTOR MOUNT

DRAWN BY ALLEN POND

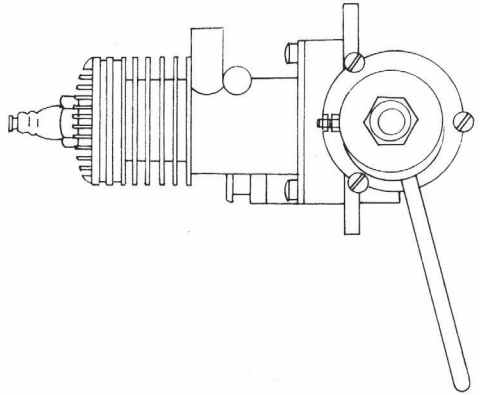
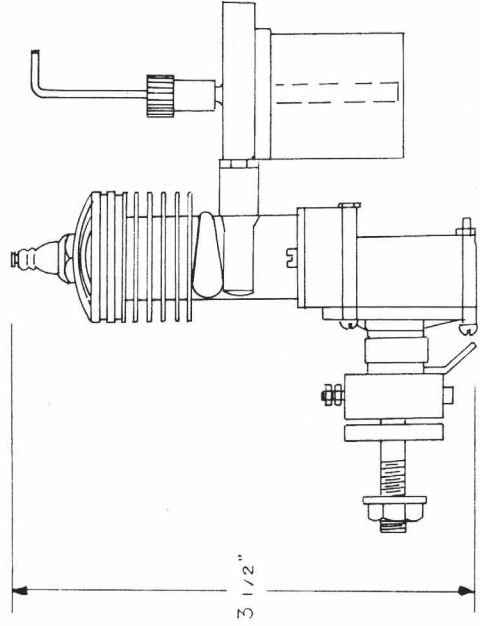
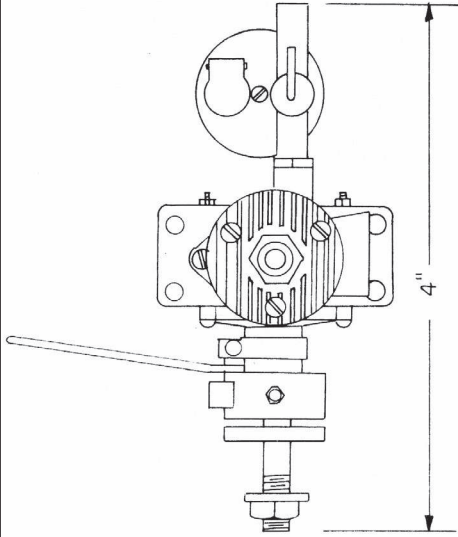

ENGINE OF THE MONTH

This month's subject is the 1940 version of the Madewell motor as produced by the Madewell Mfg. Co., 2901 E. 7th St., Oakland, California. We are indebted to Bill Simpson, who kindly loaned us a complete engine to copy. Matter of interest, this engine was originally in the Dave Brodsky collection.

Not too many old timers are aware of this motor manufacturing interest in the San Francisco Bay Area, as the large companies in the southern portion of California such as Ohlsson, Cyclone, etc., took up most of the publicity. Be it as it may, there was also a hot bed of engine manufacturers in the northern portion consisting of Madewell, Keener, Vivell, Brown, and a host of small manufacturers. We didn't mention Hornet motors as this is considered central California.

The motor illustrated this month is a follow-on to the original which featured a displacement of .147 cu. in. compared to the 1940 version at .140. This was made possible by reducing the stroke from 19/32 to 9/16, making it a "square" engine with a bore of 9/16 in. For its weight of four ounces, this Class A engine enjoyed a rating of 1/8 hp.

With an original price of \$17.50, the advertisement in the January 1940 issue of *Model Airplane News* proudly announced the new Madewell version at \$12.50. As their slogan went, "If it's a

Madewell, it's well made", was certainly an improvement over the first model.

Among the features the Madewell people pointed out in their advertisement was the new enclosed timer, the option of radial or beam mounting, transparent tank, and a fabricated steel cylinder wherein it was claimed there were no trick covers to come loose and leak.

A Smith coil designed to run on 1.5 volts was claimed as an exclusive for Madewell motors. Other features, as designed by Jack Keener, were aluminum from permanent molds. Piston and cylinder were cast iron lapped to fit after the bypass intake and exhaust manifolds were brazed onto the steel cylinder. A final cut on the bore was then made assuring a perfectly round bore free from welding distortion. The aluminum head was fitted to the cylinder with only three screws. To go this one better, the cylinder was attached to the crankcase with only two screws. Certainly didn't take much work to disassemble this motor!

Like all small motors in 1940 that were made in small lots, it didn't take Ohlsson very long to run all the rest off the market with his new Ohlsson 19. Only the Bantam as produced by Ben Shershaw was competitive (in many cases considered superior).

APEX SKYLARK

DRAWN BY ALLEN POND

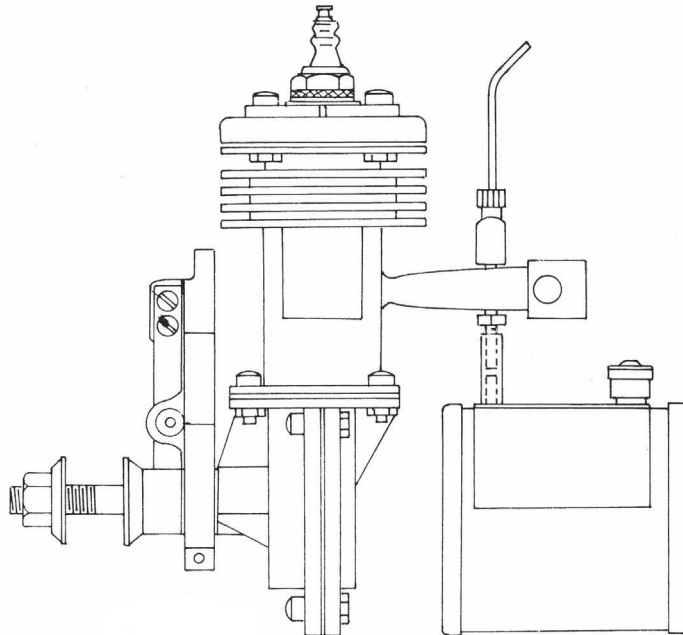
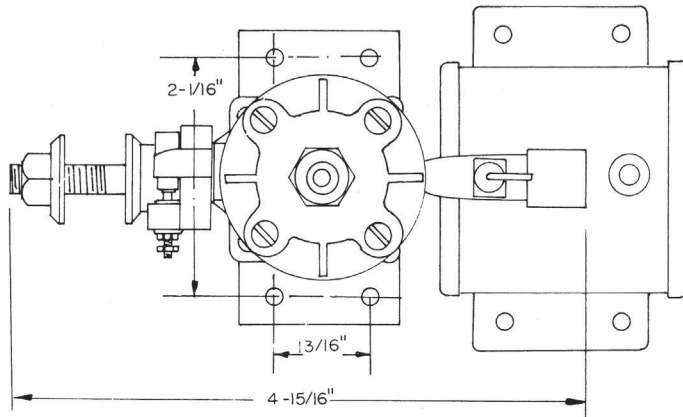

ENGINE OF THE MONTH

This month's feature engine is another one of those little known engines originating in the San Francisco Bay Area. We are indebted to David Brodsky for the kind use of his engine to make the correct drawings. (This writer no longer trusts manufacturer's drawings, etc.)

The Apex Skylark as it was known in the '40s, was produced by Apex Motors, Berkeley, California. Actually, the engine was produced in three variations, completely ready-to-run for \$14.75; a semi-finished kit for \$5.75 each; or a semi-finished kit with unfinished cylinder at \$5 each.

The Skylark was aimed at the machinists and students taking machine shop practice. The semi-finished kit was extolled as a good deal for pleasure and profit. The company claimed the finished engines would find a ready sale among their friends. The company recommended using a regular auto coil and battery for testing to avoid the more costly coil which was also offered.

For the neophyte machinist, a complete set of assembly and working drawings were provided showing every operation quite clearly and simply. Fortunately, for the newcomer, finished parts in the kit included: cylinder assembly, piston pin, piston ring, spark plug, timer spring, ignition parts, and gas lines.

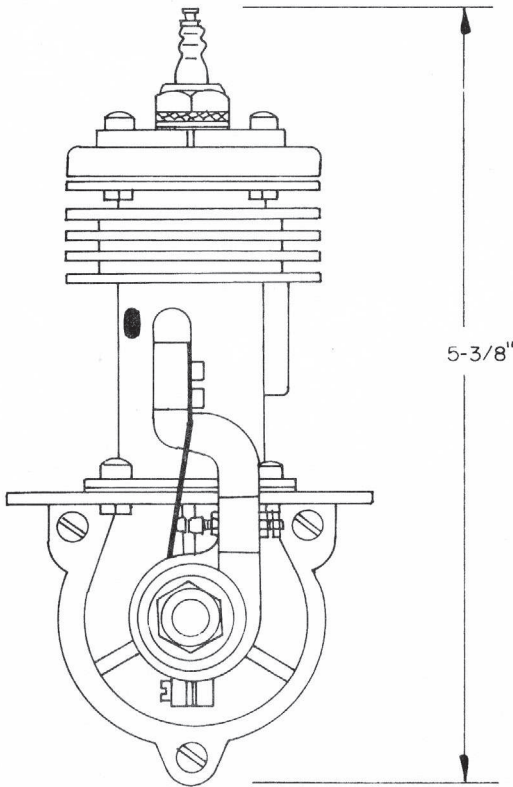

To top things off, all materials and castings necessary to complete the engine were provided. This also included bolts, nuts, and gaskets. Spark coils would have to be purchased separately.

For those who were interested in saving a buck, for 75¢ less you could do your own brazing of the cylinder attachments. However, the trick was that you had to hone the cylinder after welding.

The directions for running the motor called for six parts of gasoline to one part of SAE 70 oil. The description of how to hook up the motor (without a wiring diagram) was rather sketchy. Unless you knew your ignition setup, this writer could see problems for the beginner. One interesting fact was gleaned, and that was a setting of .010 gap for the ignition points. Good info!

For those collectors who have missed out on getting one of these engines complete, the cylinder was made of special steel tubing with the manifold and port housing brazed to the cylinder. After welding, the unit was heat treated (stress relieved), bore reamed, and honed to finish fit.

Cooling fins attached to the cylinder were pressed-on aluminum. The engine featured a silicone alloy piston; other parts were a piston ring of gray iron, a hardened and lapped steel piston pin (hollow), a connecting rod of light-weight dural with phosphor-bronze bushings, a crankshaft of hardened and lapped steel, and a balanced dural web. The crankcase was made up of split aluminum castings utilizing phosphor-bronze main bearings.

A dural timer of "banjo" design, employed auto ignition type adjustable points with the breaker cam and propeller washers made from dural. The carburetor was quite simply an Austin type needle valve with a choke quite reminiscent of the Brown Jr. engine.

Running instructions revealed that the engine was rated from 400 to 5000 rpm, propeller size not specified. Interestingly enough, when starting the engine with the spark lever perpendicular (so that the spark would occur at top dead center of the piston travel), it was claimed the engine would do equally well in either direction. This meant you advanced the timer against the direction of the propeller rotation. How about that?

The last bits of technical dope would be the bore at 7/8 in. with a stroke of 7/8 in. giving .67 cu. in. displacement. Rated horsepower was 1/5, either air or water cooled. Weight of the air cooled version was 7-1/2 ounces.

Actually, for the price, the Apex wasn't a bad motor. One often wonders what happened to its production. No question about it, the war did stop a lot of would-be manufacturers, but there doesn't seem to be much postwar information on this engine.

HORNET A

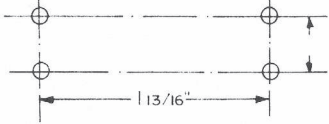

DRAWN BY ALLEN POND

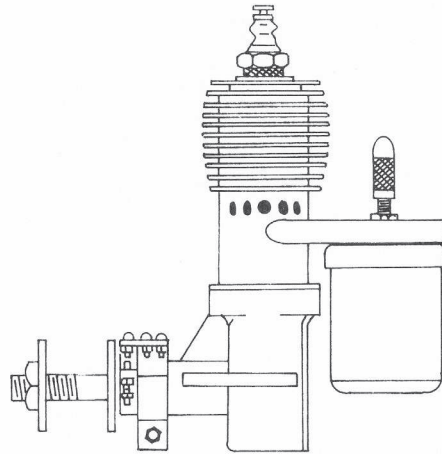
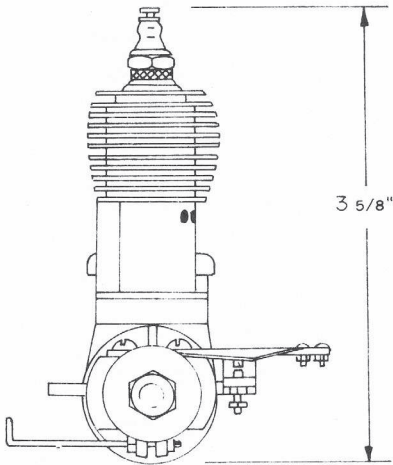
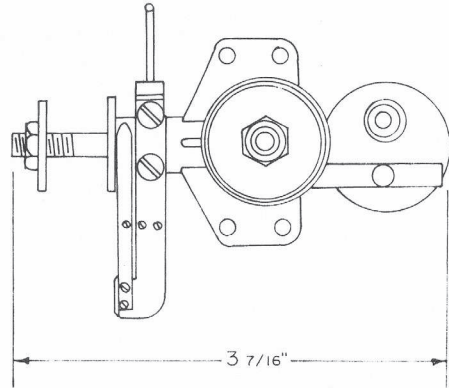
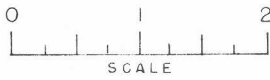

ENGINE OF THE MONTH

In the May 1982 "Plug Sparks" column, we featured an engine known as the Simplex Hornet which was produced by John Morrill. The engine we are featuring this month is the original Hornet engine as designed and built by Paul W. Lindberg, then Model Editor of *Popular Aviation*.

Lindberg had been producing a series of gas powered models (one every month for three years!) with most of the designs featuring the Hornet engine as motive power. Finally, in answer to the many requests from readers (and modelers), Lindberg prepared a two part article on how to construct this engine. These articles appeared in the January and February 1940 issues of *Popular Aviation*.

According to Lindberg, over 60 of these engines were produced at that time for use in his models and for those modelers who were associated with Lindberg. Nowadays, original Lindberg Hornet engines are to be found only in the hands of engine collectors.

This month we are again indebted to Dave Brodsky for the use of his engine. The engine has made a rather circuitous journey, at one time being owned by Bob Bowen who purchased the Ray Bunnell collection. One never knows when one of these engines will surface.

Naturally, with homebuilts such as the Hornet, variations will crop up, particularly in the timer design, tank, and needle valve arrangements. However, Hornet engines can be readily recognized even with these superficial changes.

The Hornet engine (as presented in 1940) was strictly a small type machinery job requiring at most, a simple machine lathe. Claims were made that material costs to make an engine would not exceed \$2.50. As Lindberg pointed out in his article, the biggest problem was the crankcase casting which would require the making of a pattern. This was carefully detailed in the drawings.

In making the engine, cold rolled steel was specified for the cylinder and piston. He stated the denser the material used the better. I think what he was trying to say is that the harder or better tempered material would lend itself to better machining and fit, not to mention longer wear.

Interestingly enough, the piston was ground to five ten-thousandths oversize and then lapped with the cylinder, making sure the piston was of harder steel than the cylinder.

Also made of steel are the connecting rod and the crankshaft. Lindberg recommended the crankshaft be hardened (after the flats are fitted for the breaker points) and ground to suit the crankcase. The crankpin is simply riveted or screwed into the crankshaft counterweight flange.

Probably the biggest problem facing the neophyte machinist was the handling and machining of the crankcase casting. Chucking it in the lathe for the initial drilling and back cover work goes fairly easy. To drill and tap the top of the crankcase to accept the cylinder would require a method of holding the crankcase. Lindberg recommended using an angle plate to bolt to the crankcase holes. This portion of the work is accomplished after the crankcase bearing is pressed in place.

Regardless of the foregoing, the Hornet was a good home project for learning about internal combustion engines. It's just a shame that Lindberg didn't think to provide casting kits for this motor.

As pointed out previously in the Simplex Hornet article, the Hornet A was not truly a Class A engine as its 5/8-inch bore and 3/4-inch stroke gave it approximately a .22 cu. in. displacement, a bit large for Class A with its limitation of .199 cu. in.

Figures on the running ability of the engine are quite sparse. Ten-thousand rpm was claimed, but no propeller size was indicated. John Morrill, manufacturer of the Simplex Hornet claims better figures than this for his engine. John does indicate that the Hornet as designed would have problems getting up to the 9,000 to 10,000 rpm mark.

The particular Hornet engine we drew the plans from weighs in at five ounces, a very respectable weight for a small engine.

It also might be worth noting that the Hornet articles were among the last done by Paul Lindberg for *Popular Aviation*. That darn war ruined more darn good magazines!

C.I.E. 10

DRAWN BY ALLEN POND

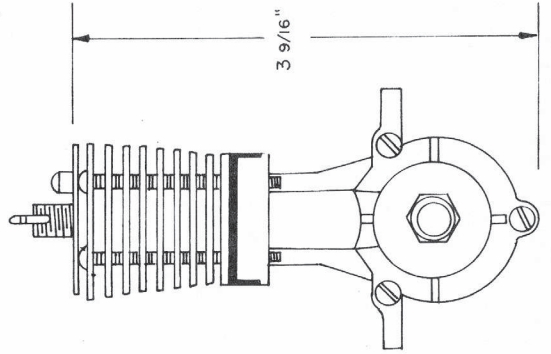
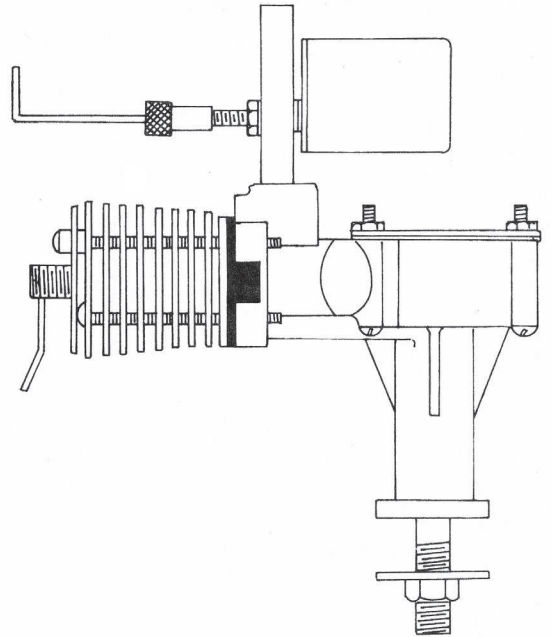
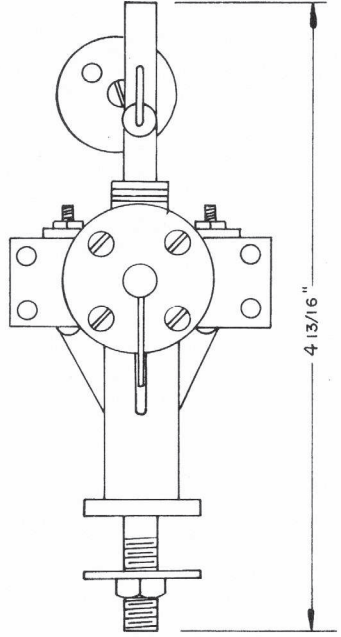
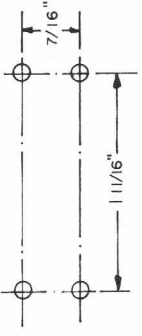

ENGINE OF THE MONTH

As this columnist has pointed out in past articles, motor manufacturers experienced the biggest boom in engine sales right after World War II. Augmenting the sales was the new fad for control-line flying. This newest fad was responsible for developing faster running, and longer lasting engines.

In search of constant improvement and increased reliability, several designers, notably Leon Shulman came out with the *diesel* engine in an effort to eliminate that constant de-bugging of the ignition circuit.

Following that lead, Barney Snyder of Modelcraft, introduced the C.I.E. engine which stood for Compression Ignition Engine. This is truly descriptive of what all model "diesel" engines really are. A true diesel engine has its fuel injected into the combustion chamber while under the compression stroke.

Not too many people are aware of Bill Brown's (of Brown Jr. fame) influence on this motor. If you look at the engine carefully, many features of the old Brown Jr. become apparent: longstroke, rear port induction, the 1946 C.I.E. version's Brown Jr. Model B type tank, and the general arrangement of the crankcase.

This small displacement engine allowed the use of small models with much less noise. As a matter of record, this columnist used to fly his C.I.E. powered model inside the National Guard Armory, the meeting place of the San Francisco Vultures. Those were great days . . . until the complaints started coming in about the hardwood floors being stained with fuel.

In 1946, the first advertisement for this motor appeared in *Model Airplane News*. The ads bragged about swinging a 10-inch propeller at 7500 rpm. This was no idle statement for an engine of only .14 cu. in. displacement! Indeed, it was a fine little engine, once you got the hang of running it!

Diesel engines have peculiar properties of sound which are just the opposite of the audible running symptoms of glow or ignition engines. When the engine knocks, it is not running lean, but rather it is running rich! Conversely, when the engine runs in quick bursts which make it sound like it is running rich, it is actually running with a lean needle valve setting! Confusing, huh?

It's so easy to get the hang of starting a diesel engine . . . simply release the compression about a quarter of a turn, start the engine, and *adjust the compression* for maximum rpm. In very few cases do you ever touch the needle valve once it is set!

The C.I.E. engine was rather simply made as the cylinder was turned out of aluminum bar stock, then fitted with a mehanite liner and chrome-moly steel head. Hardened steel chrome was also

used for the piston. An interesting feature of the tubular steel connecting rod was the bronze piston pin (the English call this the gudgeon pin) which eliminated the need for bushings. A brass bushing was provided on the conrod for the crankpin connection. The main crankshaft bearing was of "oilit" bronze.

The crankshaft was unusual in that it was a permanent mold casting of 356 heat treated aluminum alloy. For the technically minded, the C.I.E. engine featured a bore of 1/2 inch and stroke of 3/4 inch giving a displacement of .147 cu. in. Bare weight was noted at 5-1/2 ounces, which is good when you recall that there were no ignition components required.

Fuel requirements were a little different for the C.I.E. as they called for one part ether, one part white gas, and one part SAE 40 oil. This contrasts greatly with the standard diesel mix of equal parts of ether, kerosene, and castor oil. Some tests have indicated that a heavier weight oil gave better compression and easier tuning for the C.I.E. engine.

With the emergence of the glow engine, the diesels quickly fell into disfavor, both from the standpoint of fuel availability and power output. The high speed diesel had not been developed yet, so another segment of our engine development passed into limbo.

C.I.E. REVISITED

Every so often, one will accept hearsay as fact and never question it for many years. Such is the case of the C.I.E. recently featured in our "Engine of the Month". When the motor first came out, the rumor was that Bill Brown of Brown Jr. fame was involved.

Nothing could have been further from the truth. In a telephone conversation (and later backup material) with William A. Ruff of Route 2, Box 396A, Cottonwood, CA 96022, Bill stated he and Barney Snyder formed a partnership to manufacture and sell the C.I.E. engine under the name of Compression Ignition Engines, Division of Modelcraft, 11921 South Western Ave., Los Angeles, CA.

To prove his point, Bill says he still has the original casting made in a plaster of paris mold in his backyard. Bill also claims his engine is the first American diesel.

Some of the early literature on the C.I.E. bragged about how his six-year-old son, Douglas Ruff, could easily start the engine. For those who would want to see what Daymon Adcock's son-in-law looks like (Ruff married Adcock's daughter), photos of Damon's models with Doug Ruff in the picture can be seen in the July and August 1982 "Plug Sparks" column.

Anyway, we are pleased to set the record straight and hope you, the reader, will benefit by it.

MEL-Craft "29"

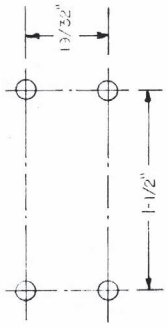

Mount Layout
DRAWN BY ALLEN POND

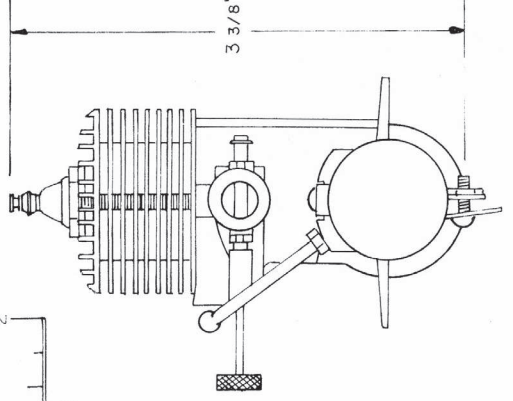
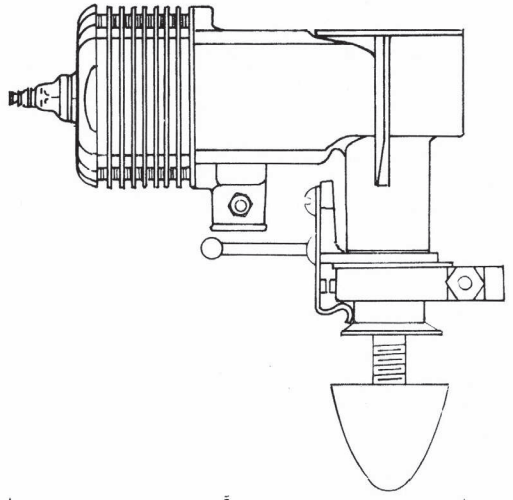
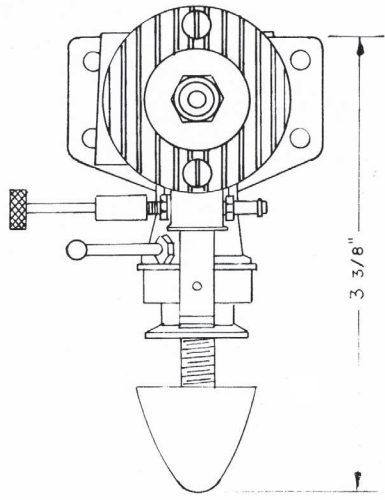

ENGINE OF THE MONTH

World War II was over, and engine manufacturers were happily producing engines to satisfy the tremendous demand built up in four years. Realizing the enormous potential, many new engine manufacturers made their appearance during this dynamic period from 1945 to 1950. Among those was the Melcraft Co. of Saginaw, Michigan with its Melcraft 29, later called the Melcraft Blue Streak.

Initial advertisements announcing this engine appeared in the December 1945 issue of *Model Airplane News* priced at \$20.75 with coil and condenser, and \$18.75 without. Most surprising was the offer for immediate delivery, inasmuch as the priorities on metals had just been relaxed by the government.

Every new motor that comes out has to have a "gimmick" to attract attention of the modeler. The Melcraft engine was no exception as their ads emphasized "Super Charged", immediately inferring the engine was superior.

Actually, before someone gets the idea that this engine had a blower, a quick examination of the drawing will show that the intake is facing directly into the propeller air blast. The upper extension of the crankcase incorporated a cast-in passage running around to the intake side of the engine. This patented feature connected to the intake, which in turn faced the prop, which theoretically pressurized the intake manifold, and forced a greater charge into the crankcase . . . hence the claim of super-charging.

One neat idea was to run this gas passage directly under the integral-cast exhaust stack to give the charge a pre-heating effect. According to figures released, this gave rpm figures of 1500 with a 12/6 prop, 6050 with an 11/6 prop, 5500 with a 10/8, and strangely enough, only 5000 with a 10/6. However, it must be remembered that propeller types were not specified. As everyone knows,

there was a heckuva difference between a Super-Scru and a Flo-Torque prop. In this same line, the company advertising brochure recommended a 10 inch by 9-8 pitch prop for control line, and a 11/4 for free flight. No rpm figures available.

An interesting note regarding tank installation for the Melcraft was contained in their price catalog. It stated that the gas tank must be mounted level with the bottom of the carburetor intake tube. This meant raising the tank considerably higher than standard rotary valve intake type engines.

In 1946, oils hadn't seen much progress, hence, the old, standard SAE 70W oil was recommended in a three-to-one ratio of white gasoline to oil. (Try finding white gas nowadays!) SAE 70W oil can be found in some of the older motorcycle shops, or from some of the engine collectors such as Dick Dwyer at 1837 Flood Dr., San Jose, CA 95124.

For the technically minded, the Melcraft 29 featured a bore of .7656 in., stroke of .625 in. giving a displacement of .787 cu. in. Weight was listed as 5-1/4 ounces, although later charts quoted an eight-ounce weight. The crankcase was die cast aluminum alloy with matching points only at the cylinder, main bearings, and cover plate. The alloy steel cylinder was "hogged" out of solid bar stock, the head being integral. Because a bronze wristpin was employed, the upper end of the alloy steel connecting rod was not bushed. A Chrysler oilite bearing was provided at the crankshaft crankpin.

The Melcraft was advertised at 1/5 h.p. (same as the Brown Jr.) when turning 8000 rpm with an 11/4 propeller. Not too shabby for a Class B engine! However, no matter how good an engine performs, unless it conforms to the standard configuration of front or rear intake at crankcase level, these types enjoy only a relatively short span of popularity. And so it was with the Melcraft Blue Streak.

BAAB-FOX

DRAWN BY ALLEN POND

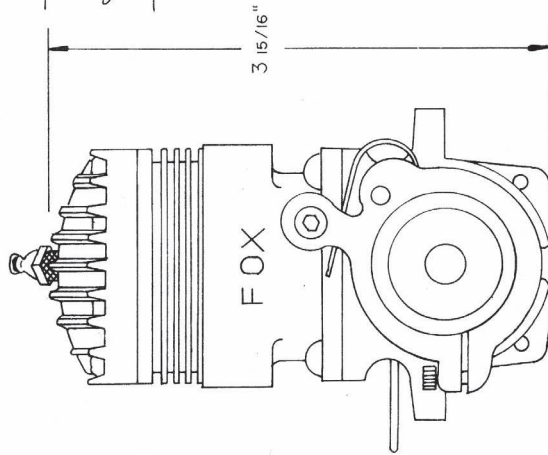
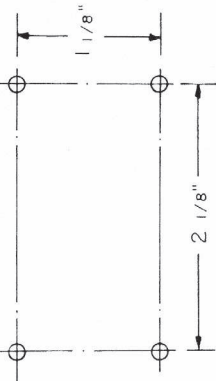

BAAB
MODEL
PROD
BACKSIDE
OF CASE

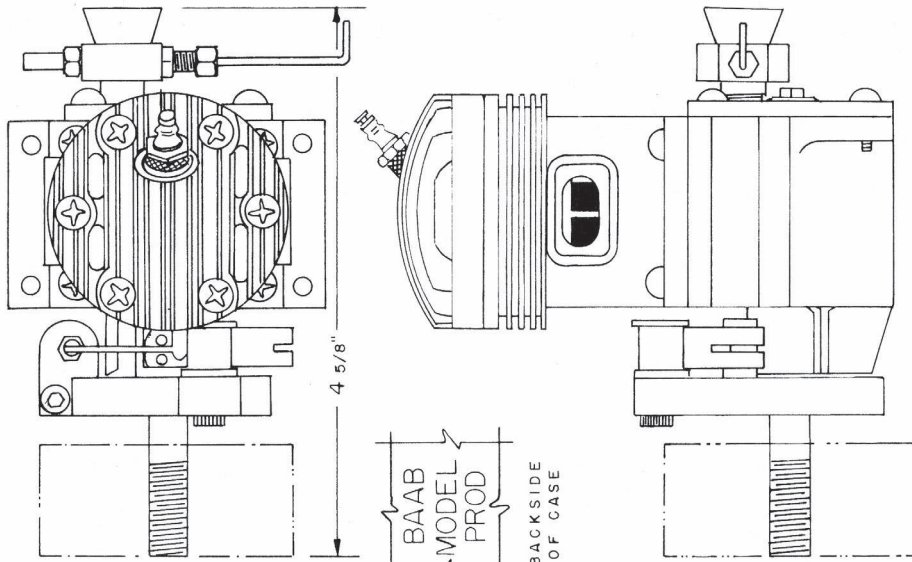

ENGINE OF THE MONTH

This month's engine is another design emanating from the San Francisco Bay area. The engine described is the Baab-Fox as designed by Cliff Fox and manufactured by W. Lloyd Baab for race car performance.

Resembling in many ways the Ray Snow Hornet engine which was setting all sorts of records for speed and number of wins, the Fox design also had some advanced features seemingly derived by Bill Cubitt's Atomic engine.

Cliff Fox was a model race car competitor running cars primarily in Proto and Streamliner classes. Fox also ran a hobby shop at 2915 61st Avenue in Oakland devoted extensively to the race car hobbyists. Also of interest is that he produced a "Proto" race car that was quite successful.

The other half, W. Lloyd Baab, was extremely active, being the managing editor of the model race car *Rail and Cable News* located at 8215 Outlook Ave., Oakland, California.

It was inevitable that the two would get together, Fox as the designer, and Baab as the producer. The first advancement (and the only one found to date in a national magazine) appeared in the June 1946 issue of *Model Craftsman*. The engine was proclaimed as the first four port motor in the Class C Speed field. Advertised as the Fox motor, it is interesting to note the word *FOX* appeared on the front of the casting (in direct opposition to the advertising photo) while the manufacturer's name, *Baab Model Products*, appeared on the back.

At this time, we would like to acknowledge the generosity of Karl Carlson, noted engine collector, for the use of this engine. This is really the only way to compare against advertising photos in magazines as articles often take liberties with their air brushes.

Advertised by Baab Products, 1749 Pleasant Valley Ave., Oakland, California, the initial announcement stated

"small quantities" would be available after May 30th. The price was listed as \$38.00 with spark plug; higher than the Hornet and McCoy 60 engines at \$35.00. This, no doubt, led to only one "small quantity" being produced.

In taking the engine apart for measurements, the bore was found to be .9375 inches, and the stroke, .875, giving a displacement of .604 cubic inches. Aluminum sand castings were used extensively throughout, with the cylinder, crankcase, head, and piston being formed from this material.

Several interesting features showed up during disassembly. The piston came with two rings and a four-way baffle system. This idea was quite similar to what was used in the Thunderbird engines.

The hardened steel crankshaft was supported on two ball bearings while the rotor shaft was also supported by a fancy ball bearing. How deluxe! The connecting rod was of dural with bronze bearings. The sand cast aluminum head was specially domed to accommodate the four-way baffled piston.

The balance of the engine employed standard parts, the timer and needle valve assemblies looking very suspiciously like Hornet parts. Also of interest was that the crankshaft was made long enough to convert to aircraft operation in the event the engine did not gain popularity with the race car enthusiasts.

Every design method was employed to gain a few extra revolutions per minute. As noted before, the piston was of the four-way baffle type. In addition to this trick, the piston rose above the steel cylinder sleeve making combustion occur above the lines. This was similar to that idea first employed by Bill Cubitt in his "Atomic" engine design. To also improve performance, the skirt of the piston passed above the exhaust port (twin in this case) giving a sub-piston induction effect. To round things off, two grooves were machined in the liner to give a schnuerle porting effect. One of the first to do this!!

Pegasus

DRAWN BY ALLEN POND

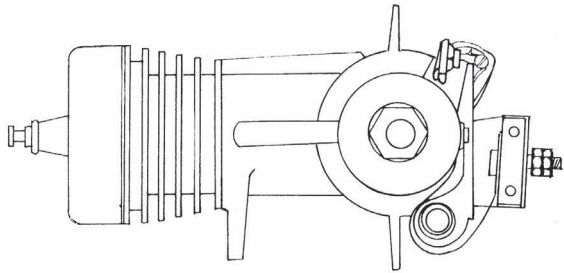
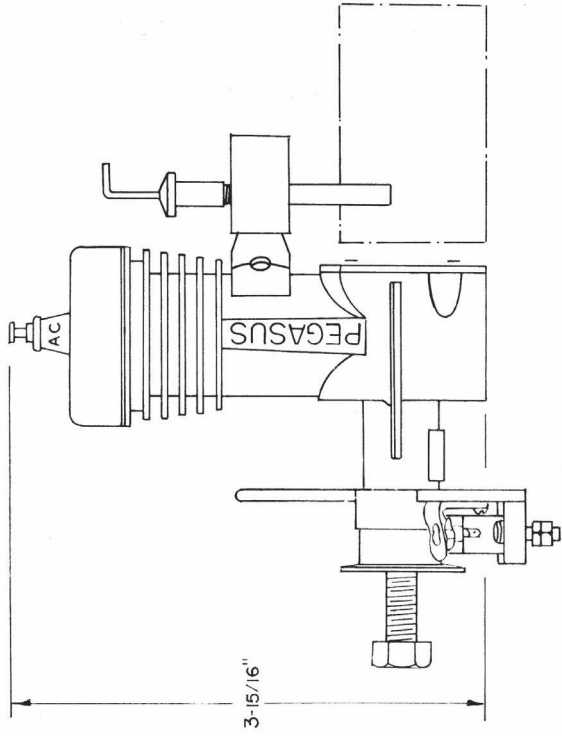
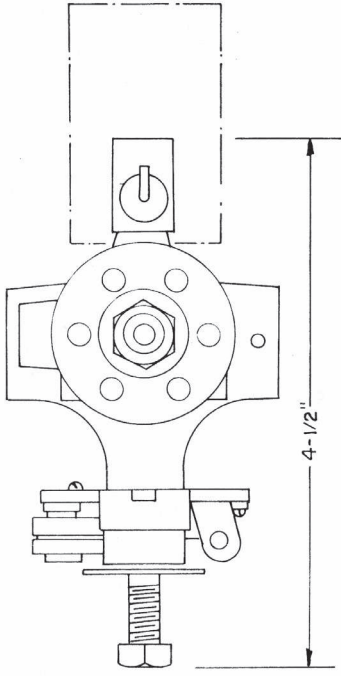

ENGINE OF THE MONTH

This month's engine is another product of the San Francisco Bay Area that failed to get off the ground, the Roll "Pegasus" 40.

Jack Roll and his son flew Ohlsson products, a Pacemaker with an Ohlsson Gold Seal Engine. They formed a partnership in flying that was good enough to win the Junior Class at the 1938 State Fair.

An aviation machinist by trade, Roll worked at the Alameda Naval Air Station. Jack was always experimenting with ways to gain more rpm, more thrust, and a better flying model. Hence, it was no great surprise to this writer when his method of mounting an Ohlsson motor was featured in the June 1938 *Model Airplane News* in the "Gas Lines" Column. As noted from the writeup:

"The gas tank serves as a motor mount, made from dural plate stamping cut to the size of the crankshaft and riveted in place. The whole unit is then mounted on a vertical dural firewall which in turn is fastened to an easily removed plywood bulkhead."

Also shown in the photo is a unique propeller, an adaptation of the Maynard Di Cesare propeller. Actual measurements indicated this staggered arrangement gave more thrust when compared to the standard prop.

Furthermore, Roll claimed that the air is drawn toward the hub and the motor runs cooler because of this. The nearest item is that the pitch of the propeller can be easily changed.

With such an inquiring mind, it was no great surprise when Jack decided to turn out an engine looking somewhat like a cross between a Gwin Aero and a Baby Cyclone. The original castings were unnumbered and unidentified. Later castings came with the name, "PEGASUS" on the by-pass.

Also, apparently because of crankshaft tempering and machining prob-

lems, the rotary valve was dropped and the updraft venturi was not drilled in the rough casting. In its place, the standard rear three port intake (resembling the Bunch engine) was installed. There is no record or photos that indicate the type tank used with this model, but it is a safe bet to assume a float or round type tank was employed.

The timer was rather massive looking, but quite practical with all parts mounted on an aluminum plate "hogged out" from solid stock. Timer points and spring arrangement were automotive type (part not identified but does look like General Motors) that could be easily adjusted for proper gap.

The engine came complete with an AC brand plug. No performance figures are available, nor is there a recommended propeller size.

In breaking down the engine, the following measurements were taken: bore, .8125 in. (13/16); stroke, .781 in. (25/32), giving a displacement of .40 cu. in. This is larger than the Baby Cyclone of .37 cu. in., and slightly smaller than the Gwin Aero.

The engine has a one-piece cast aluminum cylinder and crankcase. The crankcase rear plate was a machined piece bolted to the rear with four 3-48 screws. A machined steel head was provided, as was a cylinder liner and piston. All in all, it was not a bad looking engine.

Like a lot of the would-be engine manufacturers of that early era of gas modeling, the company was under capitalized and was unfortunately unable to advertise the product. The engine has since become a curiosity and definitely a rare engine for the collector.

As project No. 165.3, Karl Carlson indicates he will machine up a few of the castings he has in stock and complete several engines to augment several collections. That should make the collectors scramble!

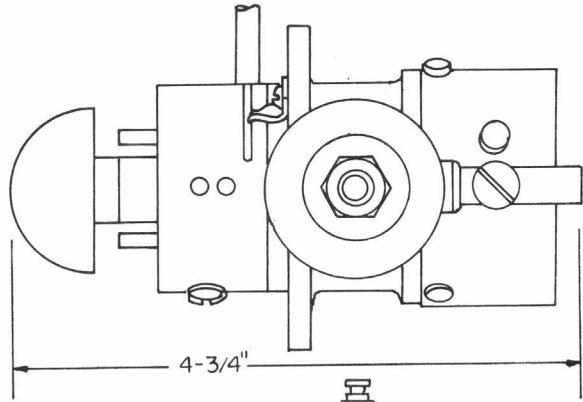

KRATMO 60

DRAWN BY ALLEN POND

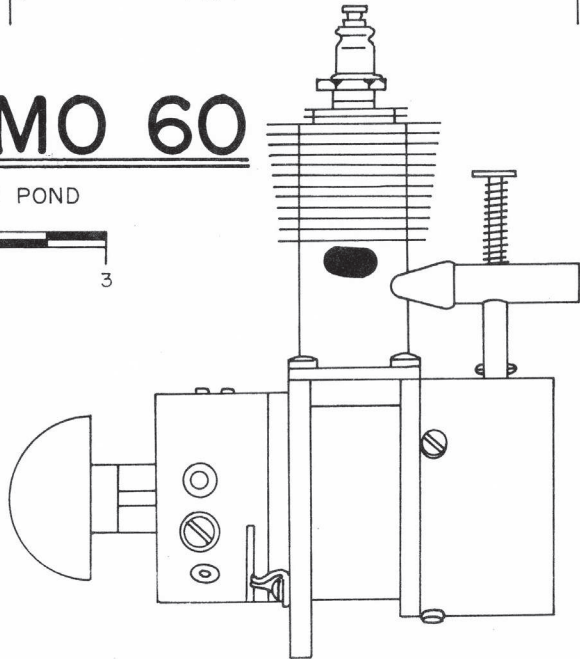

ENGINE OF THE MONTH

This month we are indebted to Jim Crocket, who runs Crocket Replicas, P.O. Box 12600, Fresno, CA 93778, who has so kindly provided this columnist with a little seen German engine.

The "Kratmo", a 10 cc production engine, was to Germany what the Brown Jr. was to America. In experiences similar to Bill Brown, the designer, Walter Kratzsch of Gosnitz, Kr. Altenburg, (near Leipzig) made up several designs before he hit it big. The Brown Jr. engine influence can be seen in his design.

In starting out, Kratzsch was a diesel engineer who founded a small factory in 1936, initially employing two men. The first engines, of course, were meant to replace the Baby Cyclone and Brown Jr., the only engines available at that time.

With the National Socialist Party (Nazi) embarking on a tremendous aviation training program, it was only natural that models in ascending complexity would be developed for the Hitler Air Youth Program. All drawings this columnist has of the early German engines called for some type of Kratmo engine.

With a successful local product available, the German government immediately requested a tremendous batch of engines, and was even willing to sponsor Kratzsch to set up a larger manufacturing facility. The net result was a modern factory in 1939 employing 120 people. According to figures available, over 15,000 engines of the Kratmo 10 type were produced.

In addition to producing the finished engines, Kratzsch also made engine kits of the Kratmo 10 for school instructional use, and for those modelers wishing to machine their own engines. These engines, although built to the instructions, show some variances, hence, the slightly different models of Kratmo engines to be found.

Walter Kratzsch, himself, was quite a versatile engineer, as he not only designed the Kratmo engines, but served as technician, manager, and even tested his own engines in models! To keep the business rolling, he also designed machine tools for the manufacture of steel cylinders, alloy pistons, and other internal combustion engine parts.

At this time, we would be remiss if we failed to acknowledge the write-up on Walter Kratzsch by Gerhard Everwyn, appearing in the MECA Bulletin #78, wherein Gerhard sketchily traces the development of the Kratzsch engines. As we run into additional information, we will be sure to feature other German engines as produced by Kratzsch.

The Kratmo 10 was the big production engine of the Kratzsch plant, being most heavily produced in the 1937-39 era. The 10 cc Kratmo engines were distinguished by a bulbous spinner, a large circular mounting flange, enclosed timer with a neat locking arm, and a sheet metal brass tank. Of course, improvements followed, consisting of a more pointed spinner, three mounting lugs to reduce the weight of the large mounting flange, and a plexiglass tank. The heads, incidentally, came in two styles, flat fins (as shown in the drawing) or vertical fins somewhat resembling a Tiger Aero head.

For those interested in the technical aspects, the Kratmo 10 featured a bore of 22 mm, stroke of 25 mm, giving a displacement of 10 cc (.60 cu. in.) and a weight of 430 grams (15 ounces). Performance figures give were .35 BHP using a 365 mm x 220 mm prop (about a 13/8) turning at 6000 rpm. One interesting fact was the clockwise rotation requiring a left handed propeller.

There are other Kratzsch engines, particularly those of Walter's nephew, who also produced a latter line of engines, that we also hope to feature in the future.

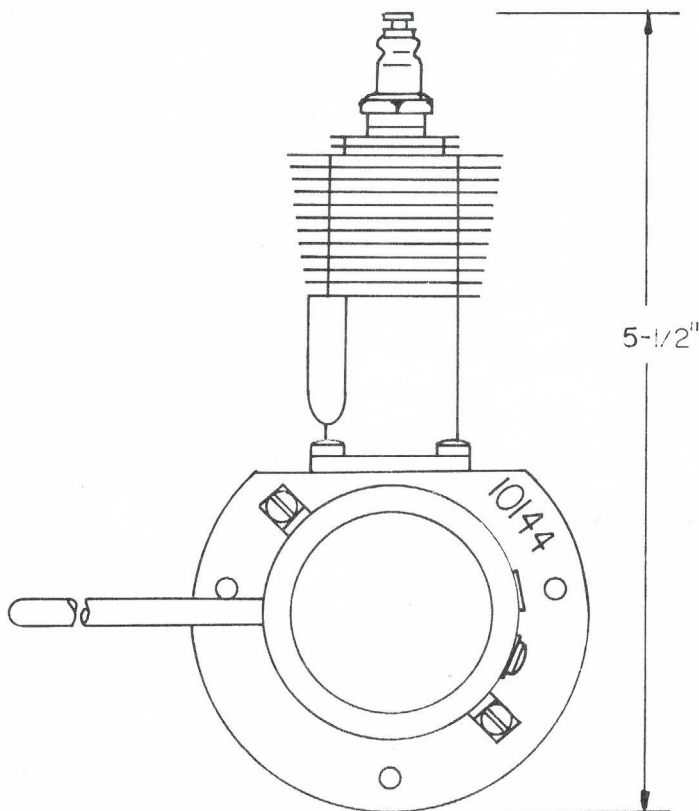

STEELE'S R. "B." SPECIAL

DRAWN BY ALLEN POND

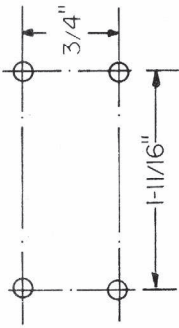

MOUNT LAYOUT

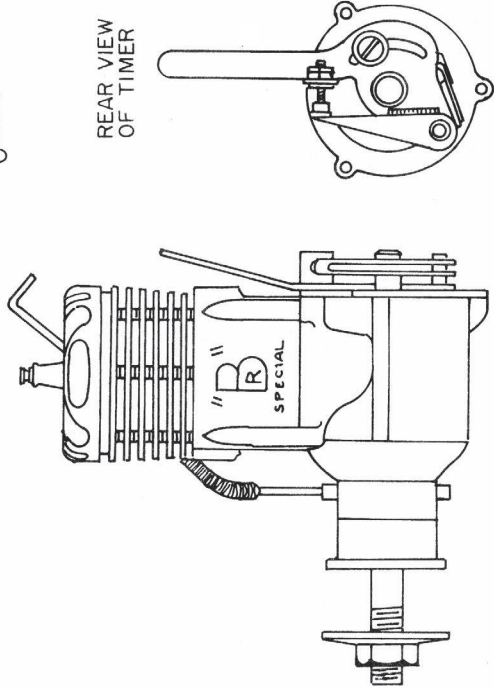
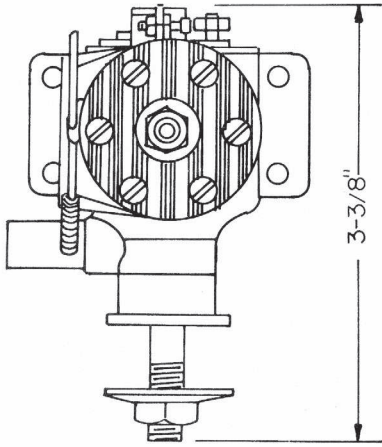
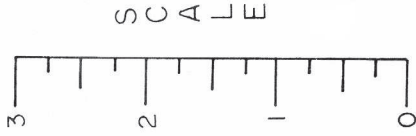
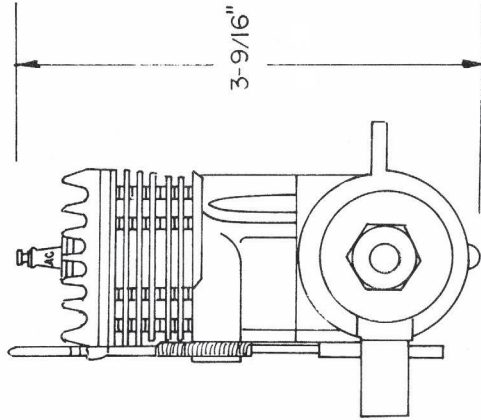

REAR VIEW
OF TIMER

ENGINE OF THE MONTH

This month, we are indebted to Karl Spielmaker, known variously as "Bearing Von Spielmaker," "Krazy Karl," etc., for his use of a rather little-known engine produced by Robert Steele directly after World War II.

Model gas competitors first became aware of Steele through the D & S (DeLong and Steele) engines that were carefully parceled out to the hot pilots in the hope that their models would win. The year 1940 was a good one for D & S, but the oncoming war negated any favorable publicity. The War Procurement Board would not authorize the use of metals for the production of model engines during this period.

During this time, DeLong and Steele were the driving force behind the design of the Cannon engines. The side draft intake was reportedly Steele's idea as he did continue this feature in some of his postwar designs. Of course, we are referring to the early sandcast versions of the Cannon engines. With the war drawing to a close, Joe DeLong and Bob Steele went their separate ways.

As most engine collectors are aware, DeLong produced an entirely different engine utilizing a rear rotor intake. Steele continued with the proven formula as can be seen in this month's subject, the R "B" Special.

This engine, first advertised in the 1946 Model Craftsman, was a product of Steele Machine Co., 10529 Aspinwall Avenue, Cleveland, Ohio. This ball bearing engine was priced at \$32.50 less coil and condenser, a rather high price for a Class B engine.

With their "exclusive timer" on the back side of the crankcase, the advertisements at that time would brag, "Mr. Dealer, give the boys the best." Another slogan noted in the ads was, "It's always in the money." No question about it, the R.B. engine was a good runner, but as pointed out in previous issues, because the timer was located in the rear of the engine, modelers looked upon this as a nuisance due to cowling problems. Many a good engine succumbed to this so-called bugaboo.

This was truly a shame as the preceding D & S engines scored impressive wins at the 1940 Chicago Nationals and the Scripps Howard Races at Akron. Somewhere along the line, the engine was passed up by the DeLong, Torpedo, and McCoy. The competition for national recognition was something fierce!

The Steele R.B. Special as a .299 cu. in. displacement engine featuring sandcast aluminum parts. This 29 was one of the first engines of that size to feature ball bearings. With an all-up weight of 8.75 ounces, this made for an excellent power to weight ratio.

To spur sales, Steele also produced a Class C version of .362 cu. in. displacement known as the Steele RB-C, still on ignition. With glow plug operation becoming so popular, the last gasp of this company was its production of an RB Special in 1950 without a timer for glow plug running. However, the price and lack of attendant National publicity (so coveted by the other manufacturers), the engine was relegated to the true title of "special" as very few were produced thereafter.

VIVELL TWIN "60"

DRAWN BY ALLEN POND

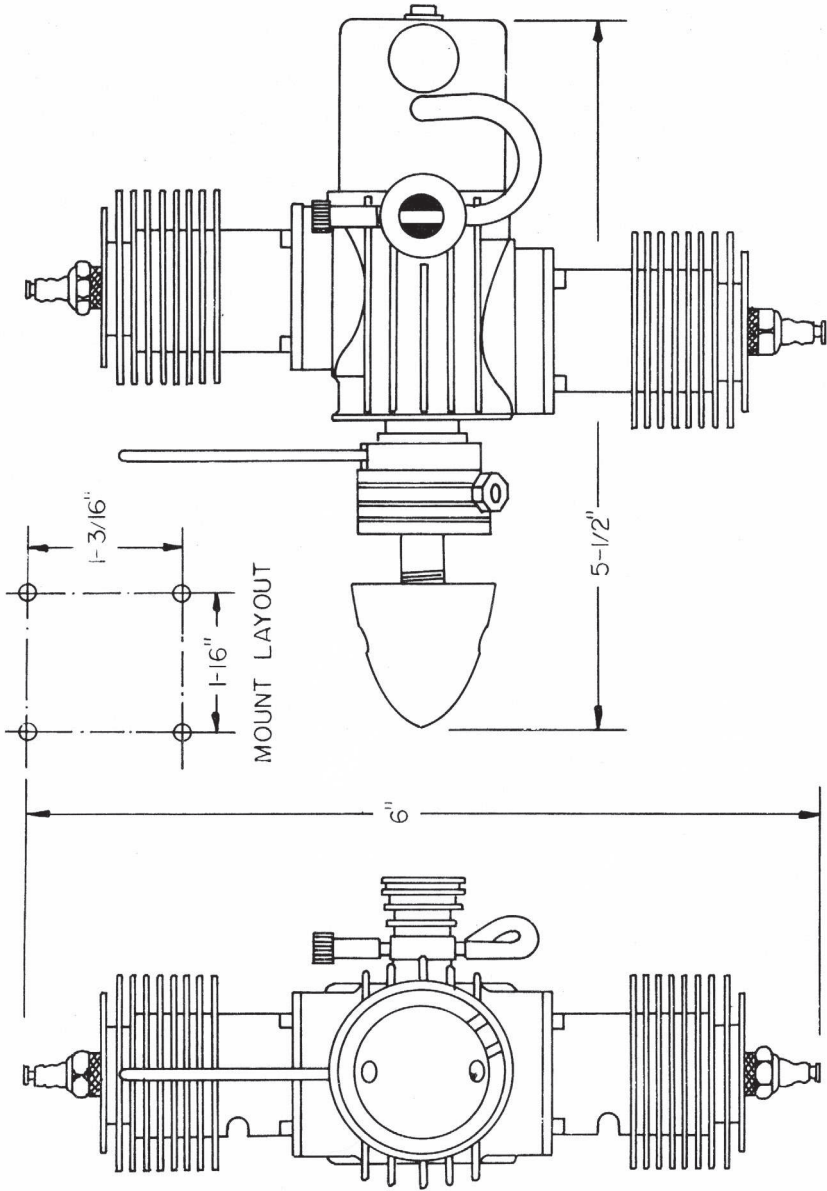
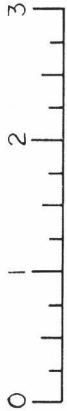

ENGINE OF THE MONTH

When you talk about Earl Vivell, you are talking about one of the earliest hobby dealers in San Francisco. This writer can remember vividly purchasing a Baby R.O.C. kit in 1929 at his shop located opposite the old Alexandria Theatre at 18th Avenue and Geary Street.

Vivell eventually expanded his shop to become a distributor of model engines in the 1935-40 era. At one time or another, he stocked (or would order) just about any engine the modeler evinced an interest in.

About 1940, after the Comet engine fiasco with Jack Keener, Vivell struck up a deal to produce an improved version called the Vivell 35. The engine had no sooner hit the hobby dealers' shelves, than World War II broke out with all its fury and the resultant rationing of materials, foodstuffs, etc.

Although metal could not be obtained for such non-military products as model engines, Keener had an excellent backlog of parts and materials. Hence, during the war, the reader would occasionally run across an advertisement of the Vivell 35 stating, "a few engines available." Availability of this engine was about the only thing that kept control line flying alive.

Free flight meets were mighty few and far between as the Civil Air patrol would spot any high thermalling model and promptly turn on the air raid sirens thinking it was a Heinkel or something.

During this time, the alliance between Offenbach Model Distributors and Jim Brown broke up. Ever alive to an opportunity, Earl Vivell promptly made a deal with Brown (not to be confused with Bill Brown of Brown Jr. engine fame) to have Jim do his machining of engines under his name. The Vivell 49 was the first, closely resembling the Brown Thermite engine.

Vivell, who had always been interested in radio control (even to the extent of building drones for the Army during WW-II), had Jim make up a twin based on the Brown layout of the Little Dynamite and the Thermite parts. The net result was the Vivell Twin 60.

Now operating out of a new location, 2470 27th Avenue in San Francisco (this was his home), Earl offered these motors at \$45.00 each less coil and condenser. Here was a fine little twin, built to the fine precision practices of Jim Brown. Although it is hard to say how many engines were produced, the Vivell Twin was around for five years, counting the period of modifications resulting in the Mk II version.

Vivell also became interested in the experiments of Emile Vollenwieter to produce the E-V magneto. Emile was no Johnny-come-lately to the magneto business having designed the Scintilla Magneto for full-sized aircraft.

The E-V magneto turned out to be quite successful, being put primarily on motors in speed cars and boats. Not to be outdone, Vivell immediately introduced the final version of the twin featuring the E-V magneto. Although it never did really catch on, (cost and maintenance being some of the problems), this magneto probably would have gained considerable popularity in old timer ignition powered models.

Getting down to basics, specifications for the Vivell 60 Twin reveal the engine has .726 in. bore and .687 in. stroke giving a displacement of .60 cu. in. Rated at 3/8 horsepower, the engine weighed only a surprising 14 ounces, less than a Hornet or McCoy engine.

First advertised in a "Hobbycrafts" ad. a Sacramento hobby shop enjoying exclusive distributorship in that area, in the September 1946 *Model Airplane News*, the first photo showed an enclosed timer. According to Don Belote, noted engine collector in Toledo, the first model featured an open timer assembly. This particular version has never been seen by this writer.

The manufacture of this engine reflects all of Jim Brown's practices: cylinder machined from solid bar stock, piston turned from special cast iron stock, piston honed and lapped to each individual cylinder, crankshaft machined from solid alloy steel bar stock, hardened and ground to a fine tolerance, and finally, the large cooling fins machined from aluminum and spun onto the cylinder. Other materials involved were bronze for the main bearing and aluminum alloy for the connecting rod with bushed bearing caps.

According to the starting directions, the Vivell people still stuck to the old reliable mix of one part of SAE 70 oil to three parts of white gas. A 13-6 propeller was recommended. Most interesting was the admonition very few modelers pay attention to: "Keep the gas/oil mixture clean. An absolute must for reliability in contest work."

In conclusion, this columnist wishes to acknowledge the generosity of Karl Carlson, one of the premier engine collectors, for the use of the Vivell Twin. There is nothing like having the original engine to make a set of drawings. In that same line, this writer is looking for engines like the Bon, BRL, Cannon, Pierce, etc., for drawing subjects. The writer fully realizes that asking for the use of these rare engines is like asking for a thousand dollars, but any help would be appreciated. Now that we are getting into the ninety mark of engines drawn, we need subjects that are not the "garden variety" of engines.

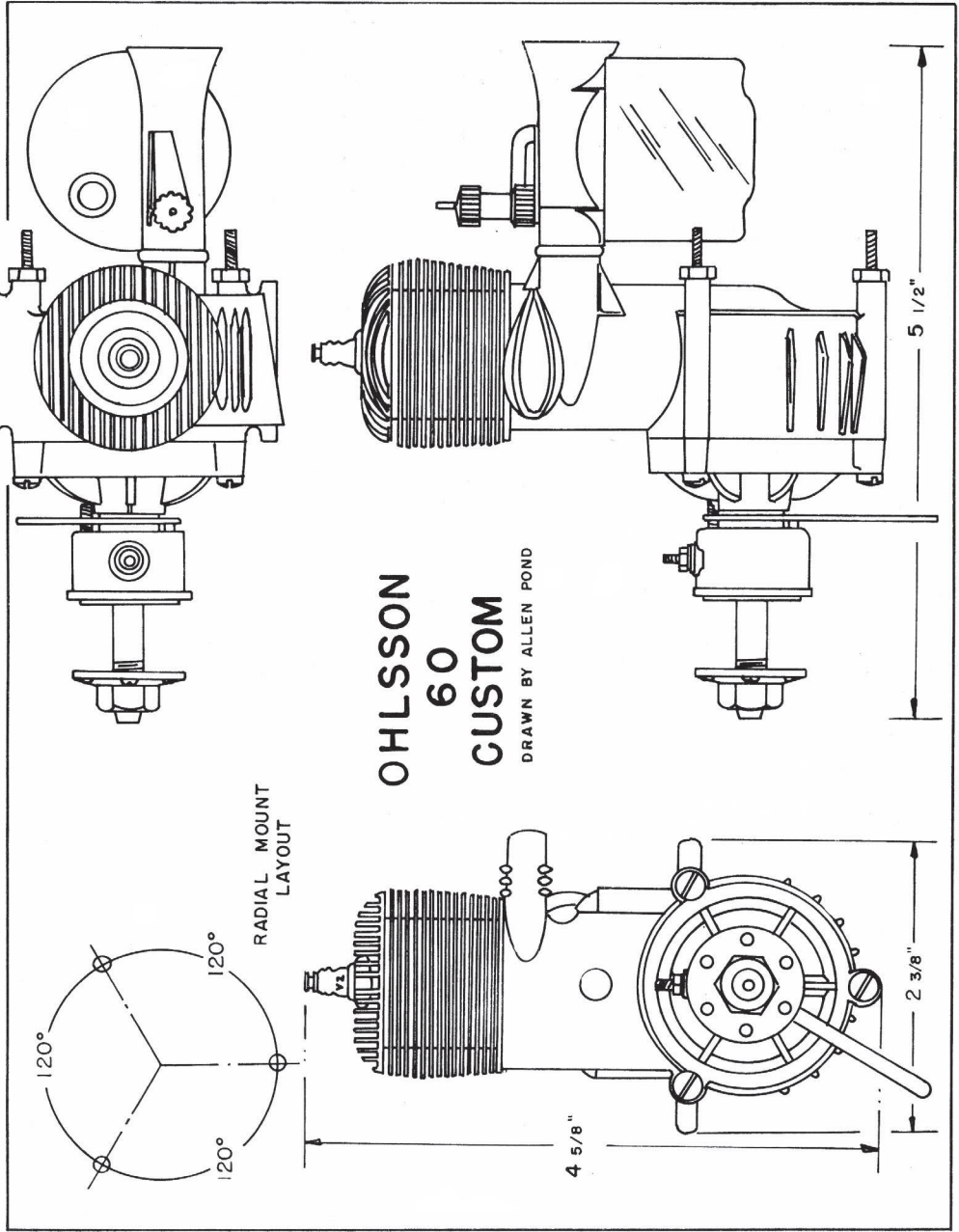

ENGINE OF THE MONTH

Having turned the engine manufacturing business literally on its ear in 1938 with his sensational Ohlsson 23, Irwin Ohlsson decided to come out with a big brother based on the successful layout of the 23.

In March 1940, the Ohlsson 60 Custom made its debut in a more sensational manner. This sixty was at least two thousand rpm better than the Brown and other comparable motors. Here was an engine that started easily, had excellent power, was easy to disassemble and repair, and best of all, it lasted!

As with the Ohlsson 23, this new 60 brought out a rash of new models designed to accommodate the power. Even Carl Goldberg's *Sailplane* design was a direct effort to take advantage of the powerful new engine. Ohlsson had established another standard for all other engines to be compared against!

When the first advertisement appeared in the March 1940 issue of *Model Airplane News*, this new engine featured a diecast tank top (with a "Jiffy-Fill" tank) with an integral air intake tube flared for a venturi intake shape. A very neat setup!

The initial engine featured a 1/4-20 spark plug and 1/4-inch diameter crankshaft priced at \$21.50. In 1941, the plug size was increased to 3/8 as was the crankshaft. Also during this time, the Custom engines were fitted with a gold eagle on the front of the case. According to Herb Wahl, noted Ohlsson expert, the eagle did not appear on the first models, being simply stamped "60" on the fusion plug of the crankcase front. (The *Flying Aces Engine Review*, December 1940, shows this.) However, most everyone remembers the Custom with that fancy eagle emblem.

On the specifications of the engine, a displacement of .617 cu. in. was listed in a *Model Airplane News* table of engines. This error in calculation, where the displacement should have been listed as .604 cu. in., has been perpetuated in subsequent publications with no corrections made.

Technically speaking, the new Ohlsson engine featured a die cast crankcase and manifold unit (including exhaust stack). The cylinder and head, machined from one piece of steel, was then spot welded to the crankcase unit. This was a system devised by Ohlsson that set it apart from all other engines.

The Custom model also featured roller bearings to support the crankshaft plus ball bearing thrust bearings to take up the horizontal play. Ohlsson, always one for making things last, provided oversize crankpins and wristpins for the engine. Very few Ohlsson engine owners ever complained about these items . . . even after extensive running!

The only way the modeler could get into the engine was through the removable front cover which, when removed, took the whole front end timer assembly and crankshaft off. The engine could be inspected, but there was simply no way for the modeler to further disassemble the engine, a mixed blessing in that one could not tinker with the engine.

Specifications of the engine called for a bore of 15/16 in. and a stroke of 7/8 in., giving the displacement of .604. The weight was 10 ounces bare, and it was priced at \$21.50, a competitive price to the Brown Jr. Performance figures as taken by the *Air Trails* strobatic tests, rate the engine at 1/4 h.p. with 6700 rpm using a 14 in. Flo-Torque propeller, 7000 with a high pitch, 12 in. prop; and 7,700 using a 10 in. dia., 10 in. pitch prop. In any case, the maximum power was stated to be at 7500 rpm.

Shortly after the introduction of the Ohlsson Custom 60, the Ohlsson 60 Special was advertised in the October 1941 *M.A.N.* issue with the attractive price of \$18.50. There apparently was only a slight difference in power output and for the difference of \$3, most modelers purchased the Special.

As time went on, the Ohlsson Custom production dropped, and the Ohlsson Special became the well-known Ohlsson 60. As pointed out before, the engine became the standard of the model manufacturing business. All subsequent engines either benefitted or suffered by comparison to the "Standard".

DIESEL 60

DRAWN BY ALLEN POND

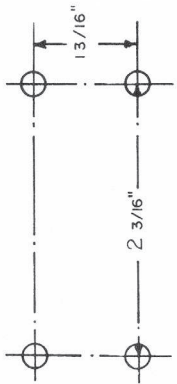

MOUNT LAYOUT

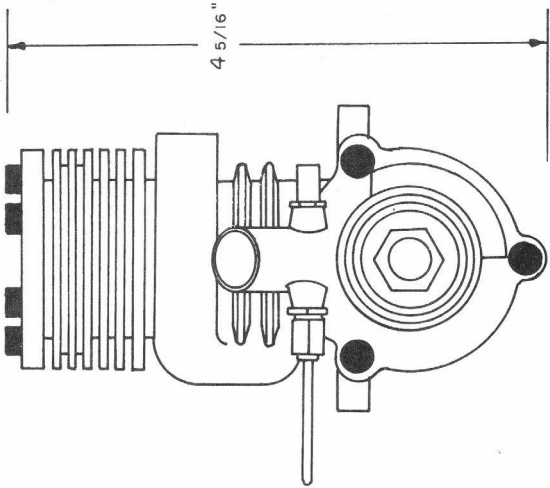
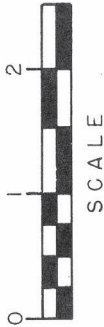
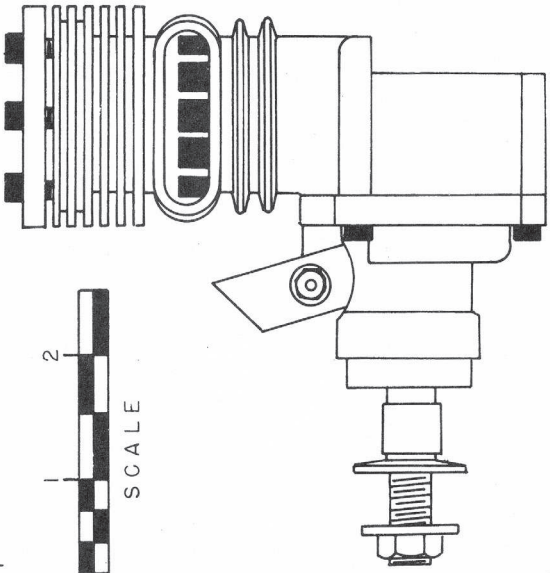
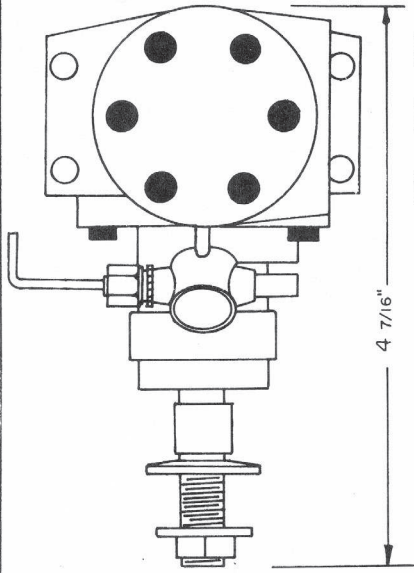

ENGINE OF THE MONTH

This month we are indebted to Gordon Coddling, 3724 John L Avenue, Kingman, AZ 86401, for the use of a little-known engine by Kencraft Co., originally located at 225 N. Seventh St., Garden Grove, California. The engine is the 1947 Ken .60 racing engine converted to diesel.

This rather rare engine lasted only a short time. The engine was produced as an attempt to take advantage of the growing interest in diesel engines that has been generated by the English motors, Leon Shulman, and others.

As can be seen by the drawing when comparing it to the Ken .60 article appearing in the March 1981 issue of **Model Builder**, very few changes were made. As a matter of fact, the engine exterior is practically identical as is the inside, i.e., bore, stroke, displacement, etc. The head was replaced by a flat plate with all timer appurtenances removed. This did make for a slightly lighter engine by a half ounce, giving a total weight of 15 ounces. Of course, there was the saving of the ignition system which was again between four and five ounces.

No performance figures are available on this engine. Even Gordon has to admit the engine has not been run in 25 years as it has been in the Smithsonian Museum all this time and just recently returned. This was the last gasp by the Kencraft Co., and shortly thereafter all production discontinued.

HI SPEED
Torpedo

DRAWN BY ALLEN POND

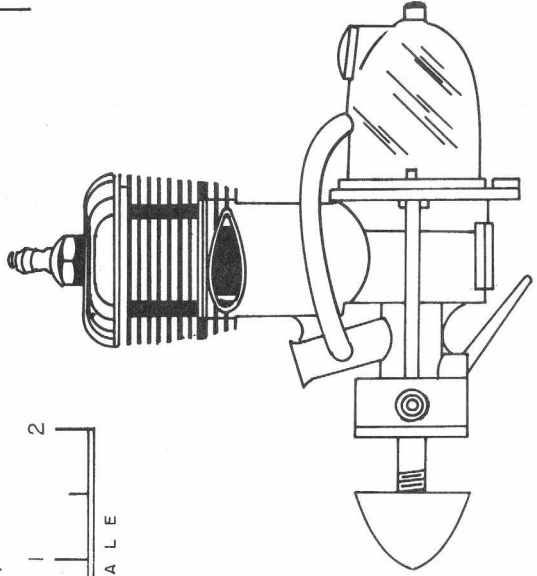
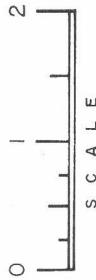
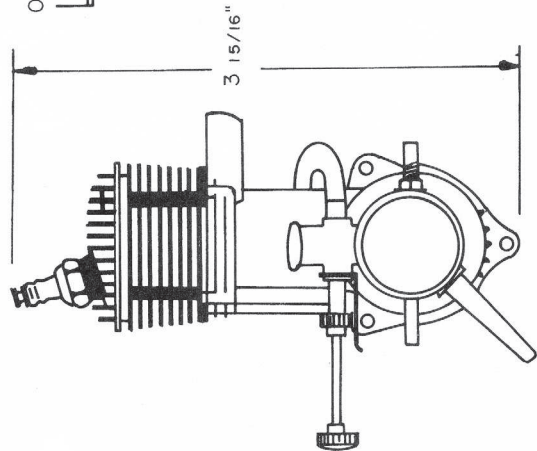
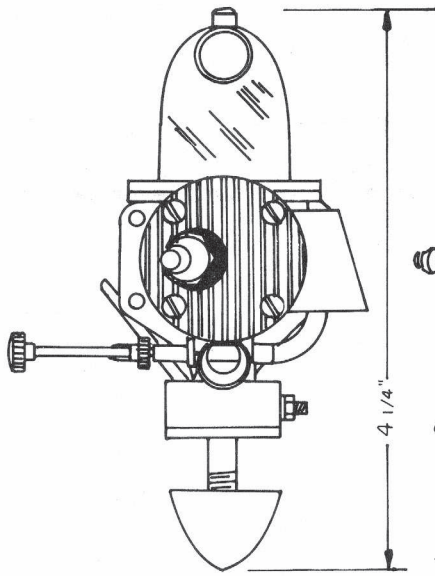
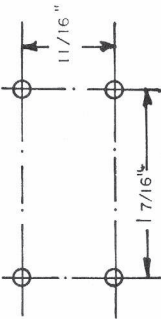

ENGINE OF THE MONTH

There is no question that when it comes to motor designs and the manufacture thereof, William E. "Bill" Atwood was the most prolific of all. At the time of the inception of this engine, Atwood had no less than five aircraft engines on the market with a whole flock of car and boat racing engines on the back burner.

Quite a bit of confusion arose over the various Atwood engines being produced back then. The first "Hi-Speed" engine (later known as the Bullet) was advertised with an address of 800 E. Gage St., Los Angeles. The Atwood Phantom was also advertised at this address. When the Hi-Speed "Torpedo" came out, the mailing address was given as 6408 McKinley Avenue, Los Angeles.

A quick look at the old Los Angeles maps show these building(s) to be the one and same with entrances fronting each street. Just another case of one hand washing the other! Regardless, Atwood's engines commanded immediate respect. These rotary valve engines were low cost, light, and ran well. This writer considers the Torpedo the foremost Class B engine produced by Atwood. Even today's famous Torpedo can trace its ancestry to this good running engine.

Of course, by making the engine light (they were made of Dow metal) the magnesium cases broke rather easily in a crash. One of the big faults was the way the engine mounting lugs, when torn loose, would reveal an open crankcase. Too bad we didn't have epoxy glues then! Even the cyanacrolates would help tremendously!

Coming out in the July 1939 issue of *Model Airplane News*, Torpedo enjoyed an immediate success. The enclosed timer was a real boon as it did keep dirt and grease out. However, on the negative side, timer springs would break easier under continual use. According to the manufacturer, the timer had been checked to 20,000 rpm.

In an effort to keep weight down, Atwood employed Dow metal (which is claimed to be 2/3 the weight of aluminum) in all die cast parts. The gas tank was made of transparent bakelite advertised as both a heat and alcohol resisting material. The crankshaft was "hogged" out of one piece of steel with a hollow crankpin, all operating on a bronze main bearing.

A steel piston was lapped to a cast iron cylinder. To round out the materials used, the connecting rod was die cast Dow metal while the wrist pin was machined from brass.

Figures differ on the displacement as the opening advertisements give the Torpedo as a .27 cu. in. engine. However, with a bore of .75 in. and a stroke of .343 in., this figures to be .304 cu. in. Later, with slight changes in the bore (.725 in.), figures were announced giving a displacement of .2989. That's about as close as you can come to .30 and still be a Class B engine!

Other figures on the Torpedo give the base weight as 4.5 ounces, and the power output as 1/5 hp (original specifications gave 1/7 hp using a 13-7 propeller ranging as high as 800 rpm).

One of the interesting items in the running of the engine is the recommended mixture of 2.5 parts gas to one part of oil. At this time, many modelers were using ratios of four and five to one; hence, this mixture seems to be a throwback to the early three to one combinations. This also helps close up the piston clearance as Bill Atwood had machined his engines for quick break-in and immediate use. This feature was later used by Brodbeck in the postwar Torpedo engines making the engine extremely popular to free flihters.

Wrapping the subject up, the engine was originally priced at \$16.50 with coil and condenser. When the "merger" of Hi-Speed and Phantom took place, the Phantom Torpedo was priced at \$10.95 ... a real buy!

CANNON

"300"

DRAWN BY ALLEN POND

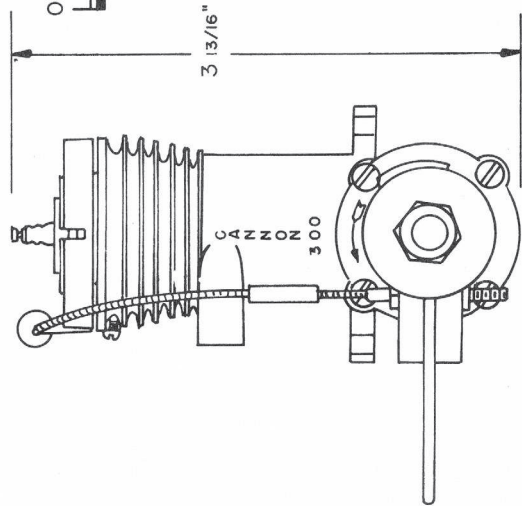
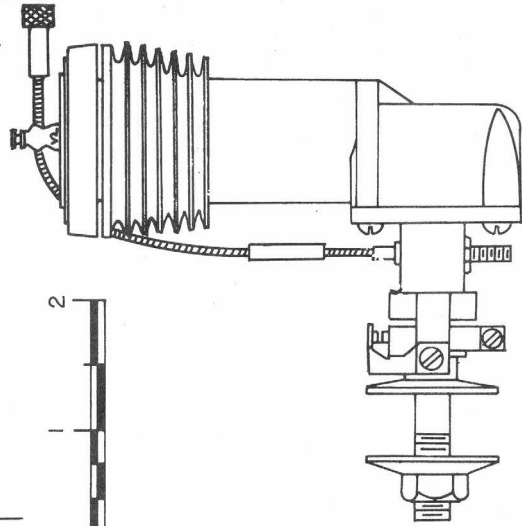
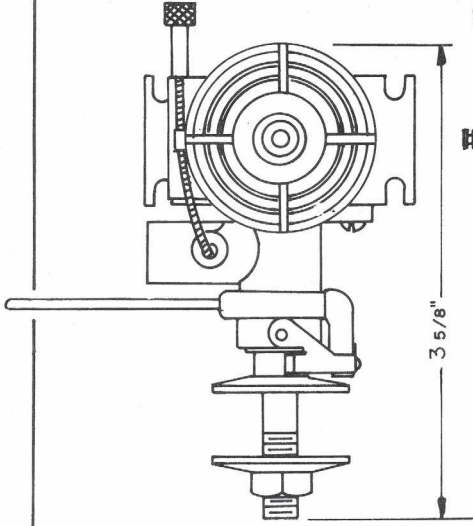
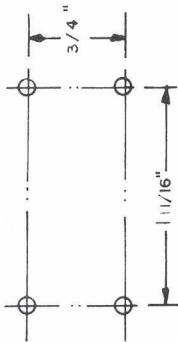

ENGINE OF THE MONTH

For this month's engine, the Cannon 300, we are indebted to Jim McMillan, 648 Martes Peak, Incline Village, Nevada 89450, for the use of the original engine. This particular Cannon engine is the 1946 version with the first 1946 timer design. Later models in 1946 featured the "Strato-Timer", designed to overcome timer floating when run at high speeds.

When the original sand cast version of the Cannon came out in 1940, the timer assembly bore a striking resemblance to the old Baby Cyclone, or for that matter, the early Atwood Bullet timer designs. (See June 1941 *Model Airplane News*, Cannon ad.)

However, the Cannon model we are referring to was first announced in the November 1945 issue of *Model Airplane News*. This was followed by a full-page advertisement in the December 1945 issue wherein the engine was shown in complete form. In spite of the full-page advertisement, no prices were quoted. Their slogan for the engine was, "The motor that lead the field when the war stopped production."

The design of the Cannon engine is generally acknowledged to be the work of Joe Delong and Bob Steele. In 1940, these semicustom engines (called D&S) were given to the hot competition flyers with the net result that they could claim first in Class B and C for their engine.

It didn't take long for the commercialized version, the Cannon 300 and 350, to make their appearance with the claim that their motors had won the Nationals. However, due credit should be given to the company as they acknowledged that the D&S engines (from which the Cannon was derived) did in fact win the Nationals at Chicago Nationals and the Scripps Howard Races at Akron, Ohio.

One of the interesting features of the Cannon engine is the side draft intake. This evidently was a method of fuel induction favored by Bob Steele as his later RB Special continued this practice. As can be noted from the foregoing, Delong and Steele left the Cannon organization sometime during the war to produce their own engines. Joe Delong's motor, named after himself, enjoyed an initial terrific success, but after a year or so, the competition had caught up and passed both Delong and Steele.

In reviewing the Cannon 300 and 350, the only difference was that the 350 was a "stroked" version of the 300, that is to say, both engines had a bore of .750 in. with strokes of .678 in. and .812 in. giving displacements of .299 and .358 respectively. Engine weights were listed as 6-1/2 ounces.

To pursue further discussion on the Cannon engines, the January issue of *MAN* (just in time for Christmas!) gave the manufacturer's address as Cannon Mfg. Co., 1878 East 18th Street, Cleveland 14, Ohio. Prices were announced as \$19.75 for the 300 engine and \$21.50 for the .358 engine. In each case, the engines came complete with the recommended 14-inch propeller, plug, coil, and condenser.

Full-page advertisements ceased with the April 1946 issue, cutting to a 1/3-page. With the advent of the new, successful Delong 30 engine, Cannon ads jumped back to full-page size in June 1946. In the October 1946 issue, the Cannon ad was reduced to a 2/3-page. The handwriting was on the wall: the new Delong 30 engine was proving to be extremely popular, and its successor in turn, the new K&B Torpedo was making tremendous inroads in the engine sales on the Pacific coast.

The main feature of the Cannon engine was the contention that the higher compression made for better running. In addition, the 1946 version had the port area increased by 20%, while utilizing a larger rotary valve at the same time.

For those interested in the technical aspects of the engine, the cylinder and crankcase were aluminum alloy die castings. An iron alloy cylinder liner was provided with the steel piston. To get away from having to provide bushings for the connecting rod, the rod was made of manganese bronze, thus providing a bronze on steel bearing surface. On the other hand, the hardened steel crankshaft ran on bronze bearings which were said to be replaceable.

Performance wise, the engine was rated at 1/5-horsepower. The manufacturer provided a special 14-inch prop which was claimed to be turned by the 300 at 5000 rpm and 5500 rpm by the 350. In a "stroker" type engine such as the Cannon, this is good performance considering the size of the propeller. However, the newer postwar engines featured higher rpm with smaller propellers that fit the needs of the smaller models at that time gaining popularity with the modelers.

By Christmas time in 1946, the Torpedo engine was definitely on the increase. The Cannon people had changed their ad to read the "dependable" engine. Thus, like so many engines that bridged the World War II era with no appreciable improvements, the introduction of the new high speed engines quickly sounded the death knell of many of the old style engines.

HURLEMAN ARISTOCRAT 48

DRAWN BY ALLEN POND



SCALE

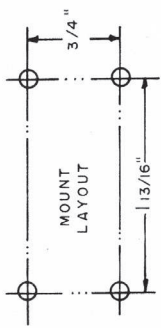

MOUNT
LAYOUT

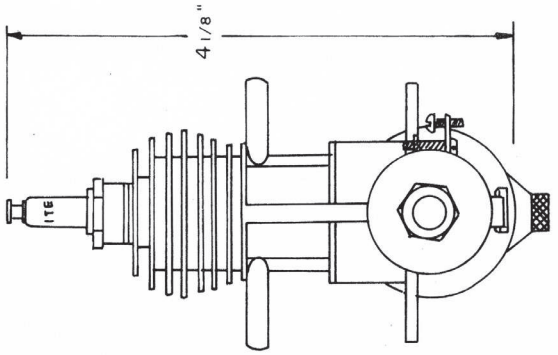
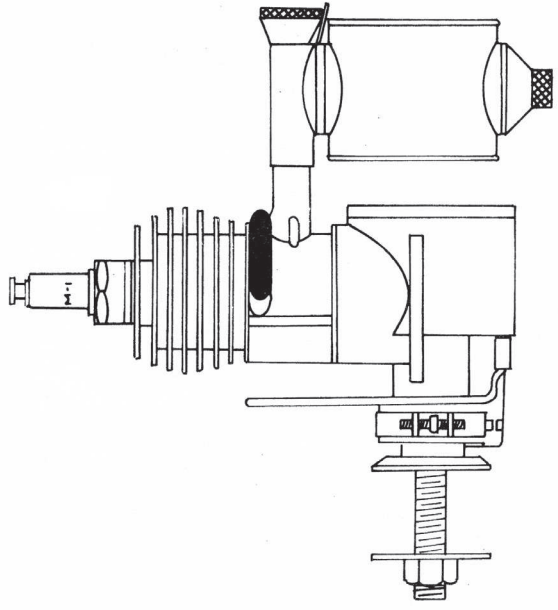
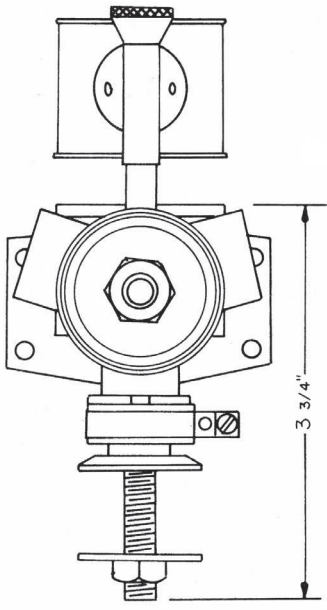

ENGINE OF THE MONTH

For this month's engine, we are greatly indebted to Herbert Wahl for not only the engine, but an excellent historical background and photographs (of which we were unable to use but one at this time).

For those "Johnny-come-latelys," Herb runs a motor manufacturing business known as "Herb's Model Motors." Located now at Box 61, Forksville, PA 18616, Herb has been turning out all sorts of Brown Jr., Hurlleman, and Ohlsson engines. To this day, this writer has yet to hear a complaint about Herb or his motors. Herb is simply one of those custom engine producers who will not sell an engine unless he has personally run it! That is one heckuva lot of engines!!

The engine we are featuring this month is the Hurlleman engine that was given to this writer at one of the O/T reunion banquets by the "boys" as a token of their esteem. This engine has been treasured to the point where it rarely sees the daylight. It has yet to be run! The engine box is carefully filed at the "home office" along with the balance of the others. This box is covered with the autographs of the donors!

When writing to Herb for information on this particular engine, this columnist was greatly surprised to find that this was the fourth engine to be named "Aristocrat." To back up a little, when Bill Brown decided to produce a few engines, he arranged with Hurlleman (who ran a local machine shop) in Philadelphia to produce a group of forty engines. These are popularly known as the Brown "A" engines that have sand cast crankcases, thin mounting lugs, etc.

As a side note, the company name, Junior Motors, was a takeoff on General Motors, then the acknowledged leader in engines and automobiles. At the time of the company's formation, Hurlleman was offered the position of head of manufacturing. Hurlleman declined, feeling that he could produce engines as good or better than the Brown Junior.

In 1936, Hurlleman began to make his own engines, a carbon copy of the Brown with the major difference being the bypass embossed with the Hurlleman marking. Although there never was a lawsuit between the two firms for infringement of design, Hurlleman decided to develop a different engine using his very successful Hurlleman timer. This was the timer you put on your Brown Jr. to make it run properly!

In 1938, Hurlleman came out with his Hurlleman Aristocrat 48 that faintly resembled the Brown. This was an entirely new engine with a very small exhaust stack. As Herb observed, a later model, the MK II, had a larger exhaust on the left side. The first model appeared in the June 1939 issue of *Model Airplane News*. The engine we are featuring was advertised directly after the war, having larger exhausts in the form of twin stacks.

According to Wahl, the Mk III was actually produced by another firm interested in the postwar boom of engine sales. After some research, an advertisement was found in the 1946 issue of *Model Craftsman* announcing that the Hurlleman engine was back under the company name of J-B-L Instrument Co., Sycamore and Mill Road, Clifton Heights, PA. The price was advertised at \$20.00, less coil and condenser. However, this was only a short-lived effort as the glow plug sounded the death knell of still another engine.

Carburetion was another interesting feature consisting of the use of a sleeve carburetor rather than a needle valve. The knurled intake knob was not a choke, but it was intended to back up the sleeve to expose the fuel orifice. This was very effective, but extremely sensitive. The flared knob provided a flared intake that allowed low loss air entry and subsequent good fuel mixing.

Probably the unique feature of the new series of Hurlleman 48 engines was the "over square" cycle. With a 7/8-inch bore and a 13/16-inch stroke, this was years ahead of its time. Properly set up, this engine was a powerful 48!

The engine shown in the drawing illustrates a metal tank, but glass tanks could be had on request. In selling the engine, Hurlleman provided the coil (of his own manufacture) called the Circle H, with a special mounting clip. The price at that time was \$21.50.

Hurlleman also made the spark plug, a two-piece design with pointed electrodes which could be taken apart and cleaned. Very few modelers ever did this as spark plugs were cheap and readily available.

As originally described, the Hurlleman was a .46 cu. in. displacement engine, weighing 6.7 ounces. Rated at 1/5 horsepower, the claimed maximum rpm was 8000 utilizing an 11-8.5 propeller.

For those who are interested, the Hurlleman Aristocrat was made of steel, iron, bronze, and aluminum. The cylinder was machined steel, and the piston was an alloy iron casting, both being machined and honed to fit. The wrist pin was bronze alloy with a hardened and lapped connecting rod. The wrist pin was bronze alloy with a hardened and lapped connecting rod. The crankcase was aluminum, sand cast with a bronze main bearing.

The Hurlleman timer, as mentioned before, was the exposed type with adjustable points. Kept clean, this timer was extremely reliable, just the ticket to replace that formed, spring steel timer employed by the Brown Jr. people.

Wrapping up this report, Photo No. 6 pretty well illustrates what this article is all about. Reading from left to right: (front) Hurlleman Twin Stack Mk III, Hurlleman Twin; (rear) Hurlleman "A", Hurlleman Aristocrat 48 Mk I, and Hurlleman 48 Mk II.

Pacemaker 59

DRAWN BY ALLEN POND

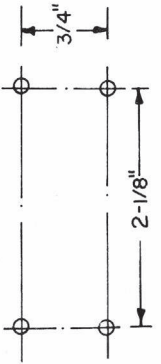

MOUNT LAYOUT

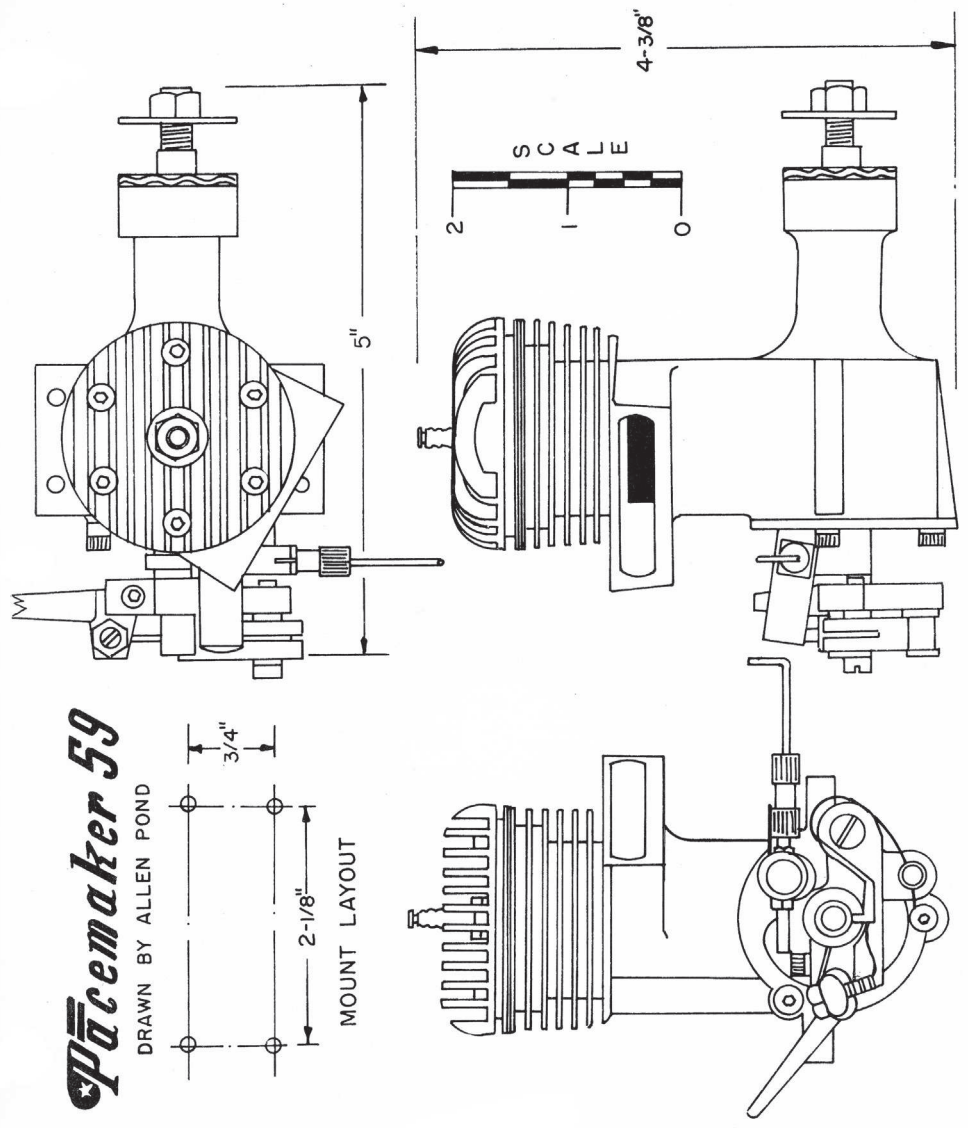

ENGINE OF THE MONTH

As usual, we must acknowledge another engine collector, Charlie Critch, for the use of his excellent Pacemaker for this month's subject. As a sidenote, it was a real pleasure to work from Critch's engine as he is quite meticulous about the shape and appearance of his engines.

Getting on to the Pacemaker, when Bill Seidler brought out this engine, it was with a tremendous amount of publicity consisting of full page color ads (in 1946!) on the back cover of *Air Trails* magazine. This lasted until November 1946 in *Air Trails* (and also in April 1946 *Model Airplane News*), moving up to the front black and white pages but still buying a full page ad. This continued until February 1947 when the ad was dropped to a quarter page.

One could almost trace the popularity and sales of the engine by the size of the ads. By April 1947, the only Pacemaker ad was being carried by Gotham Hobby Supply. *Model Airplane News* saw the complete dropping of all ads in July 1946. By June 1947, the only mention of the Pacemaker engine was in one line listing of engines by Gotham Hobby and even this petered out by September of 1947.

To this writer, when the Pacemaker first hit the market, he was reminded of a king-size Bantam engine with the major difference being the points in the rear. This excellent set of timer points never missed a beat even at revolutions of 19,000 plus.

Manufactured by Pacemaker Engines, Inc., 199 Mott Street, New York 12, New York, the initial price of the engine was pegged at \$24.95, less coil and condenser. The first model featured a one-piece magnesium sand cast crankcase with aluminum head. The later follow-on model was a die cast crankcase looking very much cleaner in appearance.

This writer had three Pacemakers, purchasing the first at \$24.95. As the popularity of the engine fell off, the columnist bought another at \$9.95 and then a close-out at \$4.95! It's truly a shame the way the engine went downhill in two years!

The Pacemaker was an excellent running engine that had all the neat characteristics of a Bantam engine. However, again, the modeler was unable to accept the idea of points in the rear as it did interfere with effect cowling.

Then too, the Pacemaker was a sort of in between engine; not quite as hot as a Hornet or McCoy 60, yet would outperform popular engines like Super Cyclone and Ohlsson 60. The weight of thirteen

ounces base was no great help as this seemed to fit between the red hots (at 16 oz.) and the standards (at 8 to 10 oz.). In addition, the Pacemaker engine failed to win any great success at the Nationals (at that time a most important feature to the aspiring modeler). As the old saying goes, "Nothing succeeds like success."

Looking the Pacemaker over, one finds the engine featured a bore of .930 and a stroke of .875 (over-square) giving a displacement of .594 cubic inches. As mentioned previously, the crankcase was a one-piece magnesium casting with a mehanite sleeve and mating steel piston.

An interesting aspect of the engine was the aluminum bronze alloy connecting rod that required no bearings. The crankshaft was a one-piece forging (a la large size automobile engines) machined and ground to fit the two supporting ball bearings. The intake was a simple brass tube machined and threaded into the rear crankcase cover.

Carburetion was via a rotary dish valve type with the ground steel disc valve being driven by the crankshaft crankpin. The timer system was based on standard automobile points run off the rotary disc valve shaft, again extending from the rear.

In summary, the Pacemaker was truly a custom built engine. In that respect, Bill Seidler spared no expense as the engine fits were so good as to eliminate the need for gaskets.

The engine featured extra large cooling fins which helped dissipate heat at high rpm. The exhaust stack was slanted back at 15 degrees to take advantage of an old speed flyers trick of preventing back pressure in the cylinder.

The *Air Trails* write-up on the Pacemaker gave rather glowing performance reports of 13,000 rpm with a 10-9 propeller (for speed) and 9,600 rpm with a 14-8 pitch, a rather large propeller, for free flight. As could be expected from an automotive timer, there was no miss at any speed, exhibiting rock-steady ignition. Flywheel performances showed the engine turning 19,000 rpm with no appreciable overheating.

Here was an engine that apparently had everything going for it, but the modelers prejudice of points in the rear was too much to overcome. Hence, the Pacemaker was just another excellent engine that failed to make it during those frantic years of 1946 thru 1949 where more new engines made their appearances than any other time in modeling history.

